

CMOS Single 8-Channel Analog Multiplexer/Demultiplexer

FEATURES

- **-3dB Bandwidth: 180MHz**
- **Single Supply Operation +2.5V to +5.5V**
- **Low ON Resistance, 48Ω(TYP) With 5V Supply**
- **High Off-Isolation: -83dB (RL = 50Ω, f = 1MHz)**
- **Break-Before-Make Switching**
- **Binary Address Decoding on Chip**
- **Operating Temperature Range: -40°C to +125°C**
- **PACKAGES: SOIC-16, SSOP-16, TSSOP-16 and TQFN-3x3-16L**

APPLICATIONS

- **Sensors**
- **Analog and Digital Multiplexing and Demultiplexing**
- **A/D and D/A Conversion**
- **Signal Gating**
- **Battery-Operated Equipment**
- **Factory Automation**
- **Appliances**
- **Communications Circuits**

DESCRIPTION

The RS2251 is a CMOS analog IC configured as an 8-channel multiplexer. This CMOS device can operate from 2.5 V to 5.5 V.

The RS2251 device are digitally-controlled analog switches. It has low on-resistance (48Ω TYP) and very low off-leakage current (1nA TYP).

The RS2251 is available in Green SOIC-16, SSOP-16, TSSOP-16 and TQFN-3x3-16L packages. It operates over an ambient temperature range of -40°C to +125°C.

Functional Diagrams of RS2251

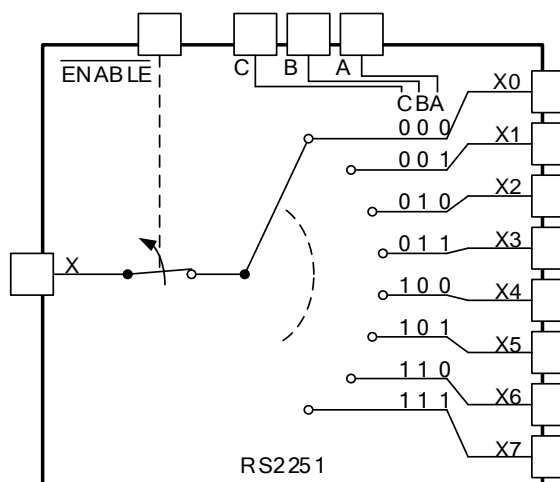

PIN CONFIGURATIONS

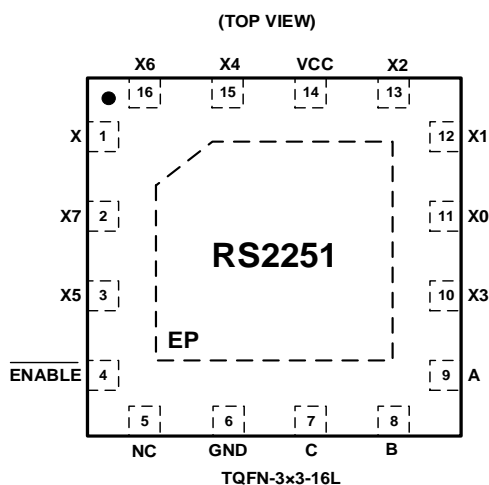
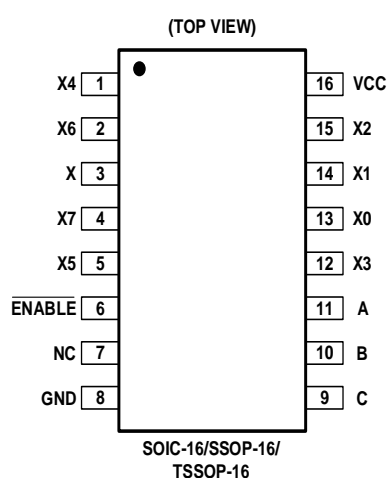

PIN DESCRIPTION

NAME	PIN (SOIC-16/SSOP-16/TSSOP-16)	PIN (TQFN-3×3-16L)	FUNCTION
X0-X7	13,14,15,12,1,5,2,4	11,12,13,10,15,3,16,2	Analog Switch Inputs X0-X7.
X	3	1	Analog Switch "X" Output.
Vcc	16	14	Positive Analog and Digital Supply Voltage Input
A	11	9	Digital Address "A" Input.
B	10	8	Digital Address "B" Input.
C	9	7	Digital Address "C" Input.
GND	8	6	Ground. Connect to digital ground.
NC	7	5	No Connect.
$\overline{\text{ENABLE}}$	6	4	Digital Enable Input. Normally connected to GND.
EP	—	Exposed Pad	Exposed Pad. Connect EP to GND.

FUNCTION TABLE

$\overline{\text{ENABLE}}$ INPUT	INPUT STATES			ON CHANNEL(S)
	C	B	A	
1	X	X	X	NONE
0	0	0	0	X0
0	0	0	1	X1
0	0	1	0	X2
0	0	1	1	X3
0	1	0	0	X4
0	1	0	1	X5
0	1	1	0	X6
0	1	1	1	X7

X=Don't care

NOTE: Input and output pins are identical and interchangeable. Either may be considered an input or output; signals pass equally well in either direction.

ABSOLUTE MAXIMUM RATINGS ⁽¹⁾

Input Terminals, Voltage. ⁽²⁾	- 0.3 to (V+) + 0.3V
Continuous Current into Any Terminal.....	±20mA
Peak Current, X _p (Pulsed at 1ms, 10% duty cycle).....	±40mA
Storage Temperature	-65°C to +150°C
Operating Temperature	-40°C to +125°C
Junction Temperature.....	+150°C
Package Thermal Resistance @ T _A = +25°C	
TQFN-3×3-16L.....	80°C/W
SSOP-16.....	64°C/W
SOIC-16, TSSOP-16.....	100°C/W
Lead Temperature (Soldering, 10s)	260°C
ESD Susceptibility	
HBM	1000V
MM	100V

ESD SENSITIVITY CAUTION

ESD damage can range from subtle performance degradation to complete device failure. Precision integrated circuits may be more susceptible to damage because very small parametric changes could cause the device not to meet its published specifications.

(1) Stresses above these ratings may cause permanent damage. Exposure to absolute maximum conditions for extended periods may degrade device reliability. These are stress ratings only, and functional operation of the device at these or any other conditions beyond those specified is not implied.

(2) Input terminals are diode-clamped to the power-supply rails. Input signals that can swing more than 0.3V beyond the supply rails should be current-limited to 10mA or less.

PACKAGE/ORDERING INFORMATION

PRODUCT	ORDERING NUMBER	TEMPERATURE RANGE	PACKAGE LEAD	PACKAGE MARKING	PACKAGE OPTION
RS2251	RS2251XS16	-40°C~+125°C	SOIC-16	RS2251	Tape and Reel,3000
	RS2251XSS16	-40°C~+125°C	SSOP-16	RS2251	Tape and Reel,3000
	RS2251XTSS16	-40°C~+125°C	TSSOP-16	RS2251	Tape and Reel,3000
	RS2251XTQC16	-40°C~+125°C	TQFN-3×3 -16L	RS2251	Tape and Reel,3000

NOTE: X = Date Code

ELECTRICAL CHARACTERISTICS

V_{CC} = 5.0 V or 3.3V, FULL= -40°C to +125°C, Typical values are at TA = +25°C.(unless otherwise noted)

PARAMETER	SYMBOL	CONDITIONS	V _{CC}	T _A	MIN	TYP	MAX	UNITS
ANALOG SWITCH								
Analog Signal Range	V _{X_} , V _X			FULL	GND		V _{CC}	V
On-Resistance	R _{ON}	V _{CC} =5V, I _X =1mA	5V	+25°C		48	58	Ω
				FULL			67	Ω
		V _{CC} =3.3V, I _X =1mA	3.3V	+25°C		100	130	Ω
				FULL			140	Ω
On-Resistance Match Between Channels	ΔR _{ON}	V _{CC} =5V, I _X =1mA Switch ON	5V	+25°C		1.5	5	Ω
				FULL			5.3	Ω
On-Resistance Flatness	R _{FLAT(ON)}	V _{CC} =5V, I _X =1mA Switch ON	5V	+25°C		17	25	Ω
				FULL			28	Ω
X __ Off, X Off, X On Leakage Current	I _{X(OFF)} I _{X(OFF)} I _{X(ON)}	V _{CC} =5V, V _{X_} =4.5V or 0V V _X =4.5V or 0V	5V	+25°C		1	1000	nA
		V _{CC} =3.3V, V _{X_} =1V or 3V V _X =3V or 1V	3.3V	+25°C		1	1000	nA
DIGITAL CONTROL INPUTS⁽¹⁾								
Logic Input Logic Threshold High	V _{AH} , V _{BH} , V _{CH} , V _{ENABLE}		5V	+25°C	1.7			V
			3.3V	+25°C	1.7			V
Logic Input Logic Threshold Low	V _{AL} , V _{BL} , V _{CL} , V _{ENABLE}		5V	+25°C			0.5	V
			3.3V	+25°C			0.5	V
Input-Current High	I _{AH} , I _{BH} , I _{CH} I _{ENABLE}	V _A , V _B , V _C , V _{ENABLE} = V _{CC}	3.3 to 5V	+25°C		1	1000	nA
Input-Current Low	I _{AL} , I _{BL} , I _{CL} I _{ENABLE}	V _A , V _B , V _C , V _{ENABLE} = 0V	3.3 to 5V	+25°C		1	1000	nA

(1) All unused digital inputs of the device must be held at V_{IO} or GND to ensure proper device operation.

ELECTRICAL CHARACTERISTICS (continued)
 $V_{CC} = 5.0\text{ V or }3.3\text{ V}$, FULL = $-40^{\circ}\text{C to }+125^{\circ}\text{C}$ Typical values are at $T_A = +25^{\circ}\text{C}$ (unless otherwise noted)

PARAMETER	SYMBOL	CONDITIONS	V _{CC}	TEMP	MIN	TYP	MAX	UNITS
DYNAMIC CHARACTERISTICS								
Address Transition Time	t _{TRANS}	V _{X_} = ±3V, R _L = 300Ω, C _L = 35pF, Test Circuit 1	5V	+25°C		150		ns
		V _{X_} = 3V/0V, R _L = 300Ω, C _L = 35pF, Test Circuit 1	3.3V	+25°C		230		ns
$\overline{\text{ENABLE}}$ Turn-On Time	t _{ON}	V _{X_} = 3V, R _L = 300Ω, C _L = 35pF, Test Circuit 2	5V	+25°C		65		ns
			3.3V			110		
$\overline{\text{ENABLE}}$ Turn-Off Time	t _{OFF}	V _{X_} = 3V, R _L = 300Ω, C _L = 35pF, Test Circuit 2	5V	+25°C		80		ns
			3.3V			130		
Internal A, B, C Rise Time	t _R		5V	+25°C		50		ns
			3.3V			80		
Internal A, B, C Fall Time	t _F		5V	+25°C		60		ns
			3.3V	+25°C		85		ns
Break-Before-Make Time Delay	t _D	V _{X_} = 3V, R _L = 300Ω, C _L = 35pF, Test Circuit 3	5V	+25°C		60		ns
			3.3V	+25°C		90		ns
Charge Injection	Q	R _S = 0Ω, C _L = 1nF, Test Circuit 4	5V	+25°C		6		pC
		R _S = 0Ω, C _L = 1nF, Test Circuit 4	3.3V	+25°C		4		pC
Off Isolation	O _{ISO}	R _L = 50Ω, f = 1MHz, Test Circuit 5	5V	+25°C		-83		dB
-3dB Bandwidth	BW	R _L = 50Ω	5V	+25°C		180		MHz
			3.3V	+25°C		180		MHz
Input Off-Capacitance	C _{X(OFF)}	V _{X_} = 0V, f = 1MHz, Test Circuit 6	5V	+25°C		4.7		pF
Output Off-Capacitance	C _{X(OFF)}	V _{X_} = 0V, f = 1MHz, Test Circuit 6	5V	+25°C		12.7		pF
Output On- Capacitance	C _{X(ON)}	V _{X_} = 0V, f = 1MHz, Test Circuit 6	5V	+25°C		16		pF
Total Harmonic Distortion	THD	R _L = 600Ω, f = 20Hz to 20kHz	5V	+25°C		0.7		%
POWER REQUIREMENTS								
Power Supply Range	V _{CC}			FULL	2.5		5.5	V
Power Supply Current	I _{CC}	V _{CC} = 5.0V, V _A , V _B , V _C , V _{ENABLE} = V _{CC} or 0	5V	+25°C		0.001	6	μA
		V _{CC} = 3.3V, V _A , V _B , V _C , V _{ENABLE} = V _{CC} or 0	3.3V	+25°C		0.001	3	μA

TYPICAL CHARACTERISTICS

Typical r_{on} as a Function of Input Voltage (V_I) for $V_I = 0$ to V_+

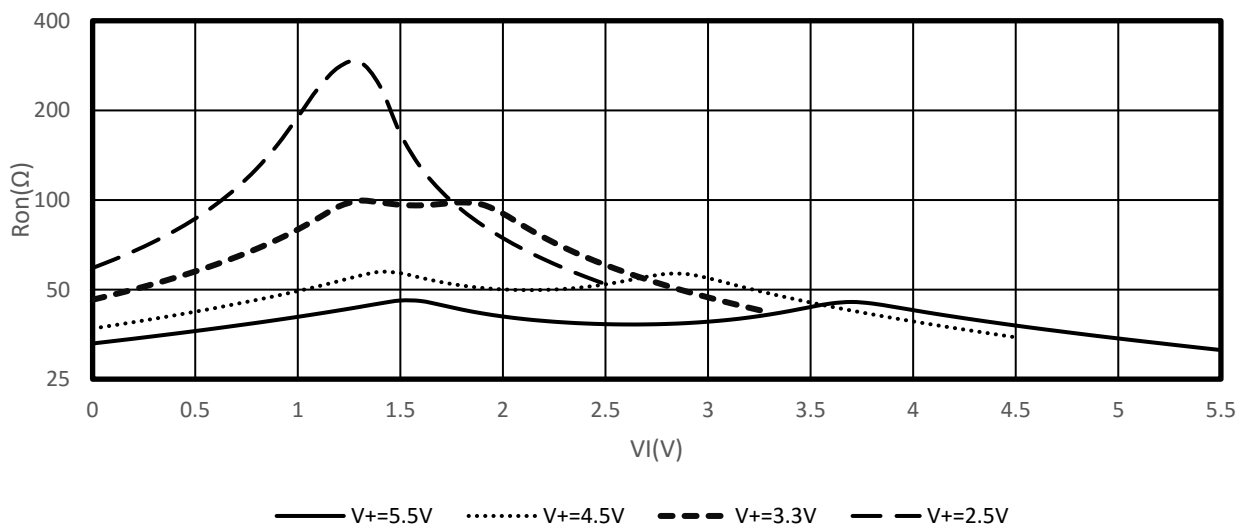

Parameter Measurement Information

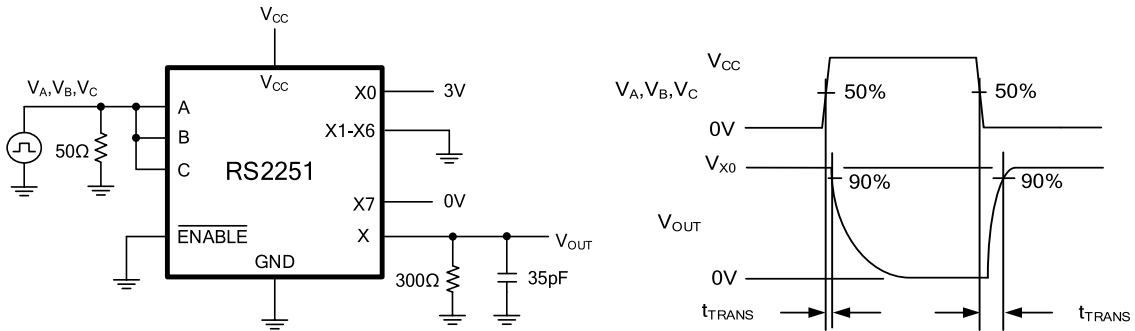

Test Circuit 1. Address Transition Times (t_{TRANS})

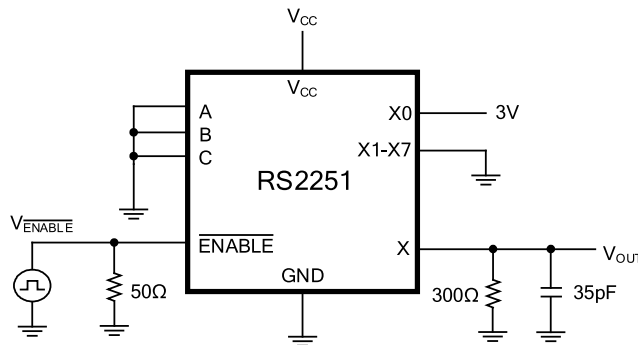

Test Circuit 2. Switching Times (t_{ON} , t_{OFF})

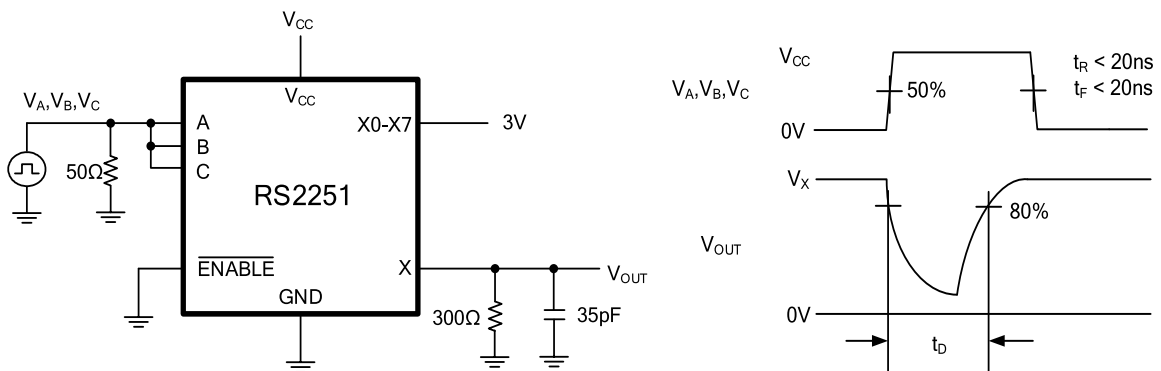

Test Circuit 3. Break-Before-Make Time Delay (t_D)

Parameter Measurement Information (continued)

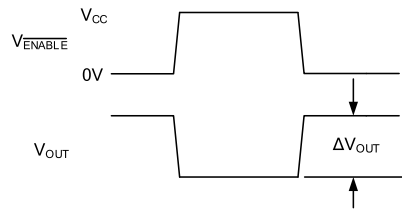
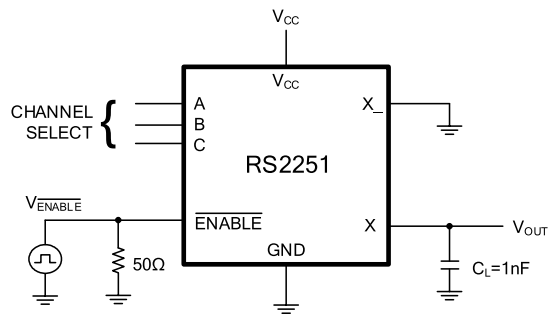

ΔV_{OUT} IS THE MEASURED VOLTAGE DUE TO CHARGE TRANSFER ERROR Q WHEN THE CHANNEL TURNS OFF
 $Q = \Delta V_{OUT} \times C_L$

Test Circuit 4. Charge Injection (Q)

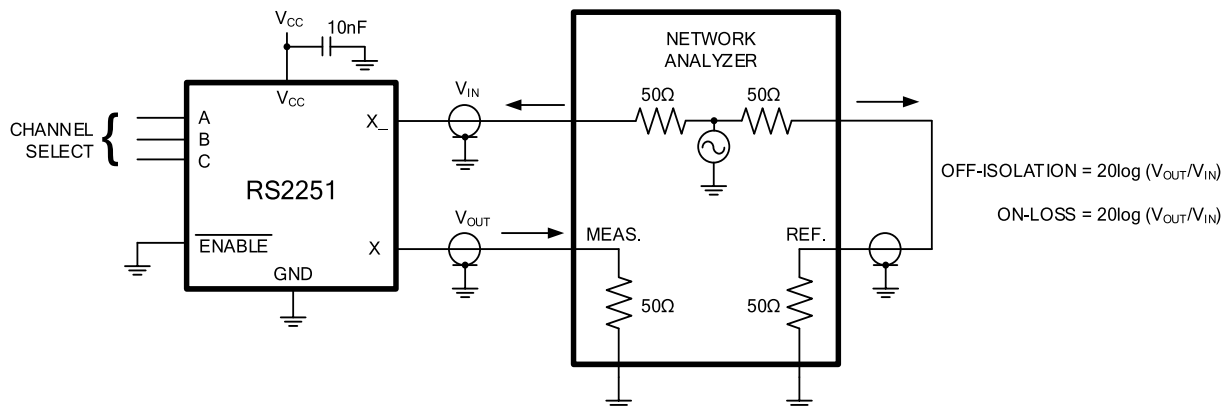

MEASUREMENTS ARE STANDARDIZED AGAINST SHORT AT SOCKET TERMINALS.
 OFF-ISOLATION IS MEASURED BETWEEN COM AND "OFF" NO TERMINAL ON EACH SWITCH.
 ON-LOSS IS MEASURED BETWEEN COM AND "ON" NO TERMINAL ON EACH SWITCH.
 SIGNAL DIRECTION THROUGH SWITCH IS REVERSED; WORST VALUES ARE RECORDED.

Test Circuit 5. Off Isolation, On Loss

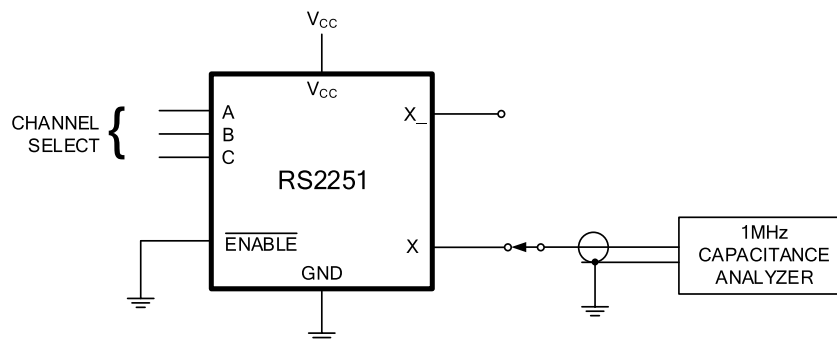

Test Circuit 6. Capacitance

APPLICATION NOTES

The RS2251 device is a single 8-channel multiplexer having three binary control inputs, A, B, and C, and an inhibit input. The three binary signals select 1 of 8 channels to be turned on, and connect one of the 8 inputs to the output.

One application of the RS2251 is to use it in conjunction with a microcontroller to poll a keypad. Figure 1 shows the basic schematic for such a polling system. The microcontroller uses the channel select pins to cycle through the different channels while reading the input to see if a user is pressing any of the keys. This is a very robust setup, allowing for multiple simultaneous key-presses with very little power consumption. It also utilizes very few pins on the microcontroller. The down side of polling is that the microcontroller must continually scan the keys for a press and can do little else during this process.

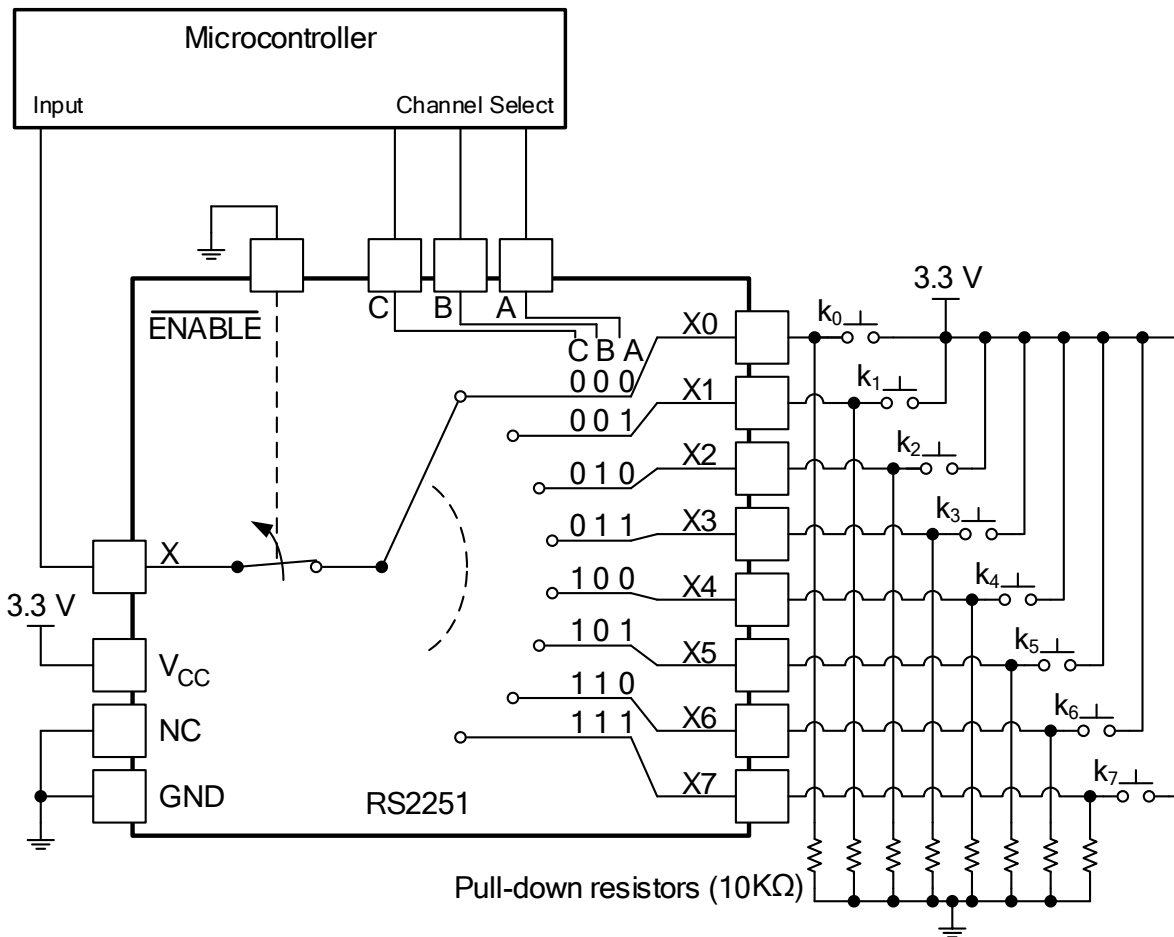
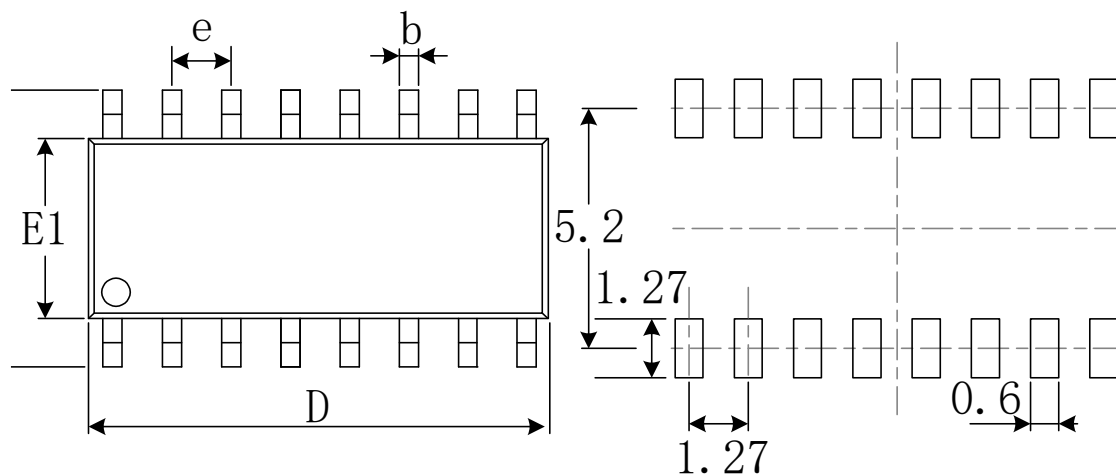
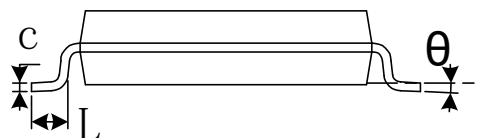
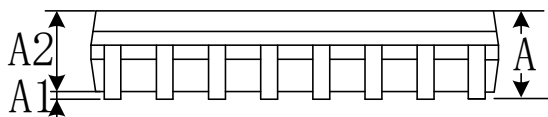

Figure 1. The RS2251 Being Used to Help Read Button Presses on a Keypad.

PACKAGE OUTLINE DIMENSIONS

SOIC-16



RECOMMENDED LAND PATTERN (Unit: mm)

Symbol	Dimensions In Millimeters		Dimensions In Inches	
	Min	Max	Min	Max
A	1.350	1.750	0.053	0.069
A1	0.100	0.250	0.004	0.010
A2	1.350	1.550	0.053	0.061
b	0.330	0.510	0.013	0.020
c	0.170	0.250	0.006	0.010
D	9.800	10.200	0.386	0.402
E	3.800	4.000	0.150	0.157
E1	5.800	6.200	0.228	0.244
e	1.27(BSC)		0.050(BSC)	
L	0.400	1.270	0.016	0.050
θ	0°	8°	0°	8°

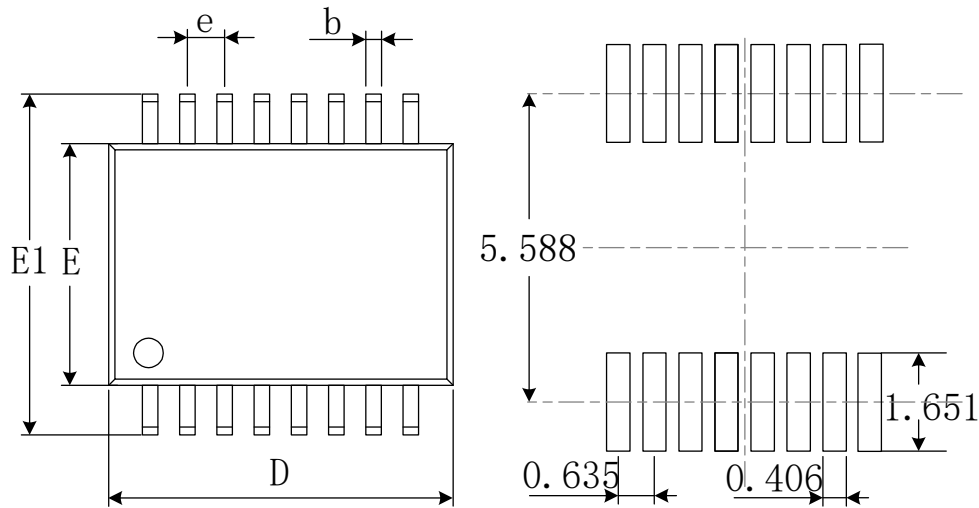
SSOP-16

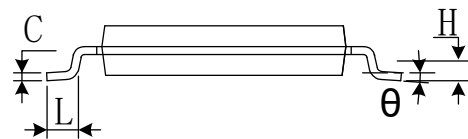
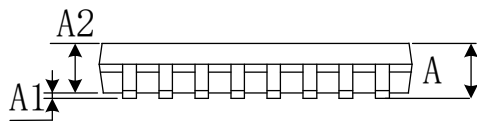

RECOMMENDED LAND PATTERN (Unit: mm)



Symbol	Dimensions In Millimeters		Dimensions In Inches	
	Min	Max	Min	Max
A	1.350	1.750	0.053	0.069
A1	0.100	0.250	0.004	0.010
A2	1.350	1.550	0.053	0.061
b	0.200	0.300	0.008	0.012
c	0.170	0.250	0.007	0.010
D	4.700	5.100	0.185	0.200
E	3.800	4.000	0.150	0.157
E1	5.800	6.200	0.228	0.244
e	0.635(BSC)		0.025(BSC)	
L	0.400	1.270	0.016	0.050
θ	0°	8°	0°	8°

TSSOP-16

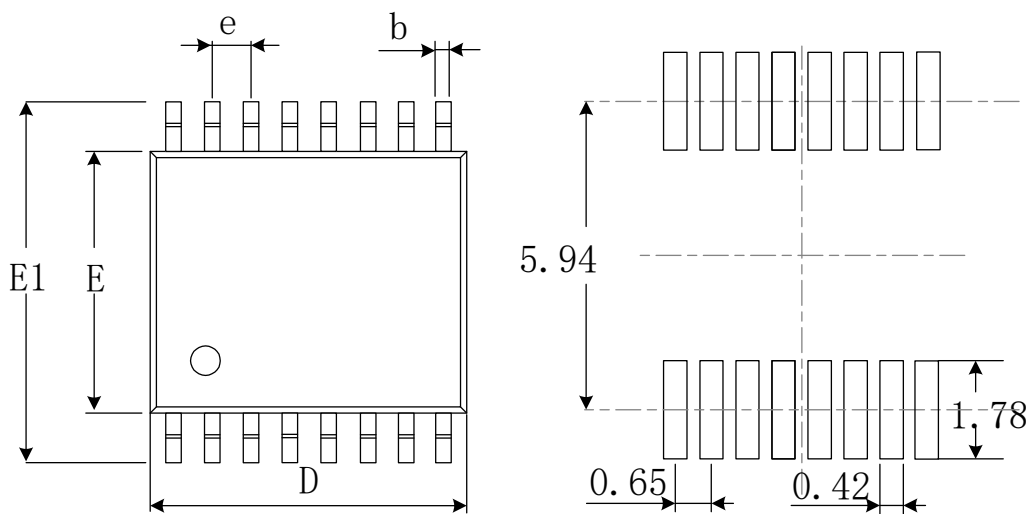
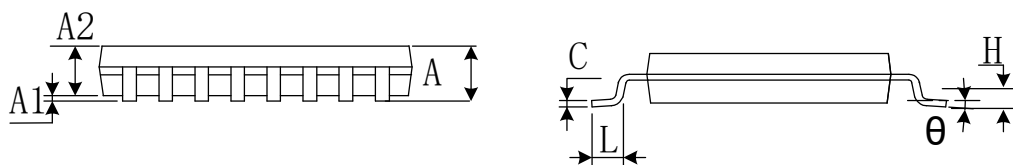
RECOMMENDED LAND PATTERN (Unit: mm)

Symbol	Dimensions In Millimeters		Dimensions In Inches	
	Min	Max	Min	Max
A		1.200		0.047
A1	0.050	0.150	0.002	0.006
A2	0.800	1.050	0.031	0.041
b	0.190	0.300	0.007	0.012
c	0.090	0.200	0.004	0.008
D	4.860	5.100	0.191	0.201
E	4.300	4.500	0.169	0.177
E1	6.200	6.600	0.244	0.260
e	0.650(BSC)		0.026(BSC)	
L	0.500	0.700	0.02	0.028
H	0.25TYP		0.01TYP	
θ	1°	7°	1°	7°

TQFN-3x3-16L

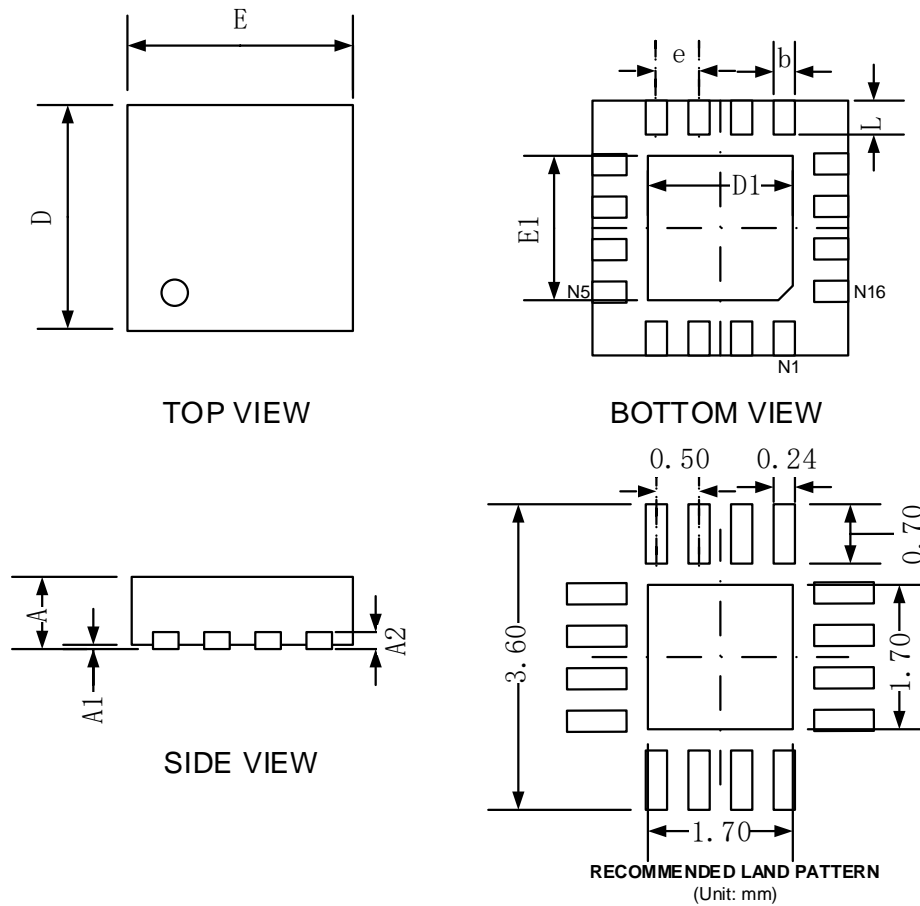

Symbol	Dimensions In Millimeters		Dimensions In Inches	
	Min	Max	Min	Max
A	0.700	0.800	0.028	0.031
A1	0.000	0.050	0.000	0.002
A2	0.203		0.008	
b	0.180	0.300	0.007	0.012
D	2.900	3.100	0.114	0.122
D1	1.600	1.800	0.063	0.071
E	2.900	3.100	0.114	0.122
E1	1.600	1.800	0.063	0.071
e	0.500 TYP		0.020 TYP	
L	0.300	0.500	0.012	0.020

X-ON Electronics

Largest Supplier of Electrical and Electronic Components

Click to view similar products for [Analogue Switch ICs](#) category:

Click to view products by [RUNIC](#) manufacturer:

Other Similar products are found below :

[FSA3051TMX](#) [NLAS4684FCTCG](#) [NLAS5223BLMNR2G](#) [NLVAS4599DTT1G](#) [NLX2G66DMUTCG](#) [425541DB](#) [425528R](#) [099044FB](#)
[MAX4762ETB+](#) [NLAS5123MNR2G](#) [PI5A4157CEX](#) [PI5A4599BCEX](#) [NLAS4717EPFCT1G](#) [PI5A3167CCEX](#) [SLAS3158MNR2G](#)
[PI5A392AQEX](#) [PI5A392AQE](#) [FSA634UCX](#) [NX3L1T5157GMZ](#) [ADG714BCPZ-REEL7](#) [HT4051ARZ](#) [TC4066BP\(N,F\)](#) [DG302BDJ-E3](#)
[ADG854BCPZ-REEL7](#) [PI5A100WE](#) [PI5A100QEX](#) [HV2733FG-G](#) [HV2701FG-G](#) [HV2301FG-G](#) [HV2301FG-G-M931](#) [RS2117YUTQK10](#)
[RS2118YUTQK10](#) [RS2227XUTQK10](#) [ADG452BRZ-REEL7](#) [MAX391CPE+](#) [MAX4744ELB+](#) [MAX4730EXT+T](#) [MAX4730ELT+](#)
[MAX333AEWP+](#) [BU4066BC](#) [MAX313CPE+](#) [BU4S66G2-TR](#) [NLASB3157MTR2G](#) [NX3L4684TK,115](#) [NX5L2750CGUX](#)
[NLAS4157DFT2G](#) [NLAS4599DFT2G](#) [NLASB3157DFT2G](#) [NLAST4599DFT2G](#) [NLAST4599DTT1G](#)