

CMOS Two 4-Channel Analog Multiplexer/Demultiplexer

FEATURES

- **-3dB Bandwidth: 180MHz**
- **Single Supply Operation +2.5V to +5.5V**
- **Low ON Resistance, 48Ω(TYP) With 5V Supply**
- **High Off-Isolation: -83dB (RL = 50Ω, f = 1MHz)**
- **Break-Before-Make Switching**
- **Binary Address Decoding on Chip**
- **Operating Temperature Range: -40°C to +125°C**
- **PACKAGES: SOIC-16(SOP16), SSOP-16, TSSOP-16 and QFN-3x3-16L**

APPLICATIONS

- **Sensors**
- **Analog and Digital Multiplexing and Demultiplexing**
- **A/D and D/A Conversion**
- **Signal Gating**
- **Battery-Operated Equipment**
- **Factory Automation**
- **Appliances**
- **Communications Circuits**

DESCRIPTION

The RS2252 is a CMOS analog IC configured as two 4-channel multiplexers. This CMOS device can operate from 2.5 V to 5.5 V.

The RS2252 device are digitally-controlled analog switches. It has low on-resistance (48Ω TYP) and very low off-leakage current (1nA TYP).

The RS2252 is available in Green SOIC-16, SSOP-16, TSSOP-16 and QFN-3x3-16L packages. It operates over an ambient temperature range of -40°C to +125°C.

Functional Diagrams of RS2252

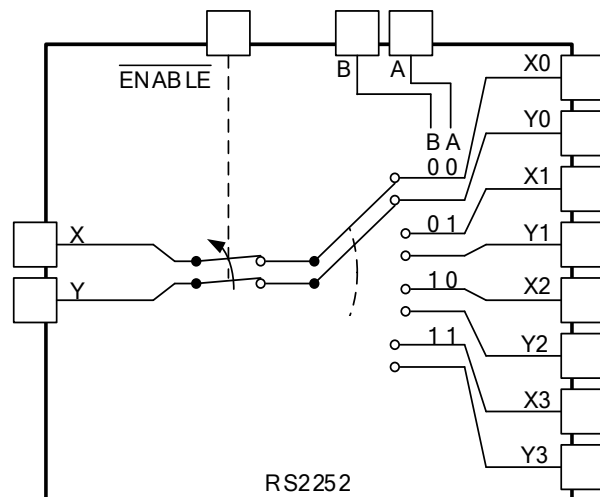

PIN CONFIGURATIONS

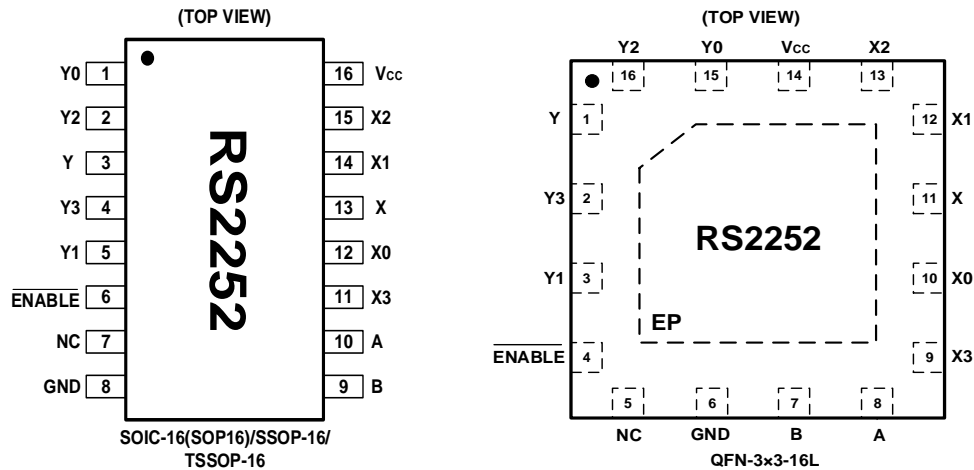

PIN DESCRIPTION

NAME	PIN (SOIC-16/SSOP-16/TSSOP-16)	PIN (QFN-3×3-16L)	FUNCTION
X0-X3	12,14,15,11	10,12,13,9	Analog Switch Inputs X0-X3.
Y0-Y3	1,5,2,4	15,3,16,2	Analog Switch Inputs Y0-Y3.
X	13	11	Analog Switch “X” Output.
Y	3	1	Analog Switch “Y” Output.
V _{cc}	16	14	Positive Analog and Digital Supply Voltage Input.
A	10	8	Digital Address “A” Input.
B	9	7	Digital Address “B” Input.
GND	8	6	Ground. Connect to digital ground.
NC	7	5	No Connect.
$\overline{\text{ENABLE}}$	6	4	Digital Enable Input. Normally connected to GND.
EP	—	Exposed Pad	Exposed Pad. Connect EP to GND.

FUNCTION TABLE

$\overline{\text{ENABLE}}$ INPUT	INPUT STATES		ON CHANNEL(S)
	B	A	
1	X	X	NONE
0	0	0	X0, Y0
0	0	1	X1, Y1
0	1	0	X2, Y2
0	1	1	X3, Y3

X=Don't care
 NOTE: Input and output pins are identical and interchangeable. Either may be considered an input or output; signals pass equally well in either direction.

ABSOLUTE MAXIMUM RATINGS ⁽¹⁾

V _{CC} to GND.....	-0.3 to 6V
Input Terminals, Voltage. ⁽²⁾	- 0.3 to (V ₊) + 0.3V
Continuous Current into Any Terminal.....	±20mA
Peak Current, X ₁ (Pulsed at 1ms,10% duty cycle).....	±40mA
Storage Temperature	-65°C to +150°C
Operating Temperature	-40°C to +125°C
Junction Temperature.....	+150°C
Package Thermal Resistance @ T _A = +25°C	
QFN-3×3-16L.....	80°C/W
SSOP-16.....	64°C/W
SOIC-16, TSSOP-16.....	100°C/W
Lead Temperature (Soldering, 10s)	260°C
ESD Susceptibility	
HBM	1000V
MM	100V

ESD SENSITIVITY CAUTION

ESD damage can range from subtle performance degradation to complete device failure. Precision integrated circuits may be more susceptible to damage because very small parametric changes could cause the device not to meet its published specifications.

- (1) Stresses above these ratings may cause permanent damage. Exposure to absolute maximum conditions for extended periods may degrade device reliability. These are stress ratings only, and functional operation of the device at these or any other conditions beyond those specified is not implied.
- (2) Input terminals are diode-clamped to the power-supply rails. Input signals that can swing more than 0.3V beyond the supply rails should be current-limited to 10mA or less.

PACKAGE/ORDERING INFORMATION

PRODUCT	ORDERING NUMBER	TEMPERATURE RANGE	PACKAGE LEAD	PACKAGE MARKING	PACKAGE OPTION
RS2252	RS2252XS16	-40°C ~+125°C	SOIC-16(SOP16)	RS2252	Tape and Reel,3000
	RS2252XSS16	-40°C ~+125°C	SSOP-16	RS2252	Tape and Reel,3000
	RS2252XTSS16	-40°C ~+125°C	TSSOP-16	RS2252	Tape and Reel,3000
	RS2252XTQC16	-40°C ~+125°C	QFN-3×3 -16L	RS2252	Tape and Reel,3000

ELECTRICAL CHARACTERISTICS

$V_{CC} = 5.0\text{ V}$ or 3.3 V , FULL = -40°C to $+125^{\circ}\text{C}$, Typical values are at $T_A = +25^{\circ}\text{C}$. (unless otherwise noted)

PARAMETER	SYMBOL	CONDITIONS	V_{CC}	T_A	MIN	TYP	MAX	UNITS
ANALOG SWITCH								
Analog Signal Range	$V_{X_}, V_X$ $V_{Y_}, V_Y$			FULL	0		V_{CC}	V
On-Resistance	R_{ON}	$V_{CC}=5\text{V}$, $I_X, I_Y=1\text{mA}$	5V	+25°C		48	65	Ω
				FULL			70	Ω
		$V_{CC}=3.3\text{V}$, $I_X, I_Y=1\text{mA}$	3.3V	+25°C		100	130	Ω
				FULL			140	Ω
On-Resistance Match Between Channels	ΔR_{ON}	$V_{CC}=5\text{V}$, $I_X, I_Y=1\text{mA}$ Switch ON	5V	+25°C		1.5	5	Ω
				FULL			5.3	Ω
On-Resistance Flatness	$R_{FLAT(ON)}$	$V_{CC}=5\text{V}$, $I_X, I_Y=1\text{mA}$ Switch ON	5V	+25°C		17	25	Ω
				FULL			28	Ω
X_ Off, Y_ Off, X Off, Y Off, X On, Y On Leakage Current	$I_{X(OFF)}, I_{Y(OFF)}$ $I_{X(ON)}, I_{Y(ON)}$	$V_{CC}=5\text{V}$, $V_{X_}, V_{Y_}=1\text{V}$, 4.5V $V_X, V_Y=4.5\text{V}, 1\text{V}$	5V	+25°C		1	100	nA
		$V_{CC}=3.3\text{V}$, $V_{X_}, V_{Y_}=1\text{V}$, 3V $V_X, V_Y=3\text{V}, 1\text{V}$	3.3V	+25°C		1	100	nA
DIGITAL CONTROL INPUTS⁽¹⁾								
Logic Input Logic Threshold High	$V_{AH}, V_{BH}, V_{ENABLE}$		5V	+25°C	1.7			V
			3.3V	+25°C	1.7			V
Logic Input Logic Threshold Low	$V_{AL}, V_{BL}, V_{ENABLE}$		5V	+25°C			0.5	V
			3.3V	+25°C			0.5	V
Input-Current High	$I_{AH}, I_{BH}, I_{ENABLE}$	$V_A, V_B, V_{ENABLE} = V_{CC}$	3.3V to 5V	+25°C		1	100	nA
Input-Current Low	$I_{AL}, I_{BL}, I_{ENABLE}$	$V_A, V_B, V_{ENABLE} = 0\text{V}$	3.3V to 5V	+25°C		1	100	nA

(1) All unused digital inputs of the device must be held at V_{IO} or GND to ensure proper device operation.

ELECTRICAL CHARACTERISTICS (continued)
 $V_{CC} = 5.0\text{ V or }3.3\text{ V}$, FULL = $-40^{\circ}\text{C to }+125^{\circ}\text{C}$ Typical values are at $T_A = +25^{\circ}\text{C}$ (unless otherwise noted)

PARAMETER	SYMBOL	CONDITIONS	V_{CC}	TEMP	MIN	TYP	MAX	UNITS
DYNAMIC CHARACTERISTICS								
Address Transition Time	t_{TRANS}	$V_{X_}, V_{Y_} = 3\text{V}/0\text{V}$, $R_L = 300\Omega$, $C_L = 35\text{pF}$, Test Circuit 1	5V	$+25^{\circ}\text{C}$		120		ns
		$V_{X_}, V_{Y_} = 3\text{V}/0\text{V}$, $R_L = 300\Omega$, $C_L = 35\text{pF}$, Test Circuit 1	3.3V	$+25^{\circ}\text{C}$		210		ns
$\overline{\text{ENABLE}}$ Turn-On Time	t_{ON}	$V_{X_}, V_{Y_} = 3\text{V}$, $R_L = 300\Omega$, $C_L = 35\text{pF}$, Test Circuit 2	5V 3.3V	$+25^{\circ}\text{C}$		70 130		ns
$\overline{\text{ENABLE}}$ Turn-Off Time	t_{OFF}	$V_{X_}, V_{Y_} = 3\text{V}$, $R_L = 300\Omega$, $C_L = 35\text{pF}$, Test Circuit 2	5V 3.3V	$+25^{\circ}\text{C}$		80 120		ns
Internal A, B, C Rise Time	t_R		5V	$+25^{\circ}\text{C}$		50		ns
			3.3V		80			
Internal A, B, C Fall Time	t_F		5V	$+25^{\circ}\text{C}$		60		ns
			3.3V		85	ns		
Break-Before-Make Time Delay	t_D	$V_{X_}, V_{Y_} = 3\text{V}$, $R_L = 300\Omega$, $C_L = 35\text{pF}$, Test Circuit 3	5V	$+25^{\circ}\text{C}$		50		ns
			3.3V		80	ns		
Charge Injection	Q	$R_S = 0\Omega$, $C_L = 1\text{nF}$, Test Circuit 4	5V	$+25^{\circ}\text{C}$		6		pC
			3.3V		4	pC		
Crosstalk	X_{TALK}	$f = 1\text{MHz}$, Test Circuit 5	5V	$+25^{\circ}\text{C}$		-110		dB
Off Isolation	O_{ISO}	$R_L = 50\Omega$, $f = 1\text{MHz}$, Test Circuit 5	5V	$+25^{\circ}\text{C}$		-83		dB
-3dB Bandwidth	BW	$R_L = 50\Omega$	5V	$+25^{\circ}\text{C}$		180		MHz
			3.3V		180	MHz		
Input Off-Capacitance	$C_{X(OFF)}$ $C_{Y(OFF)}$	$f = 1\text{MHz}$, Test Circuit 6	5V	$+25^{\circ}\text{C}$		4.7		pF
Output Off-Capacitance	$C_{X(OFF)}$ $C_{Y(OFF)}$	$f = 1\text{MHz}$, Test Circuit 6	5V	$+25^{\circ}\text{C}$		12.7		pF
Output On- Capacitance	$C_{X(ON)}$ $C_{Y(ON)}$	$f = 1\text{MHz}$, Test Circuit 6	5V	$+25^{\circ}\text{C}$		16		pF
Total Harmonic Distortion	THD	$R_L = 600\Omega$, $5V_{P-P}$, $f = 20\text{Hz to }20\text{kHz}$	5V	$+25^{\circ}\text{C}$		0.7		%
POWER REQUIREMENTS								
Power Supply Range	V_{CC}			FULL	2.5		5.5	V
Power Supply Current	I_{CC}	$V_{CC} = 5.0\text{V}$, $V_A, V_B, V_{\overline{\text{ENABLE}}} = V_{CC}$ or 0	5V	$+25^{\circ}\text{C}$		0.001	2	μA
		$V_{CC} = 3.3\text{V}$, $V_A, V_B, V_{\overline{\text{ENABLE}}} = V_{CC}$ or 0	3.3V	$+25^{\circ}\text{C}$		0.001	1	μA

TYPICAL CHARACTERISTICS

Typical r_{on} as a Function of Input Voltage (V_I) for $V_I = 0$ to V_+

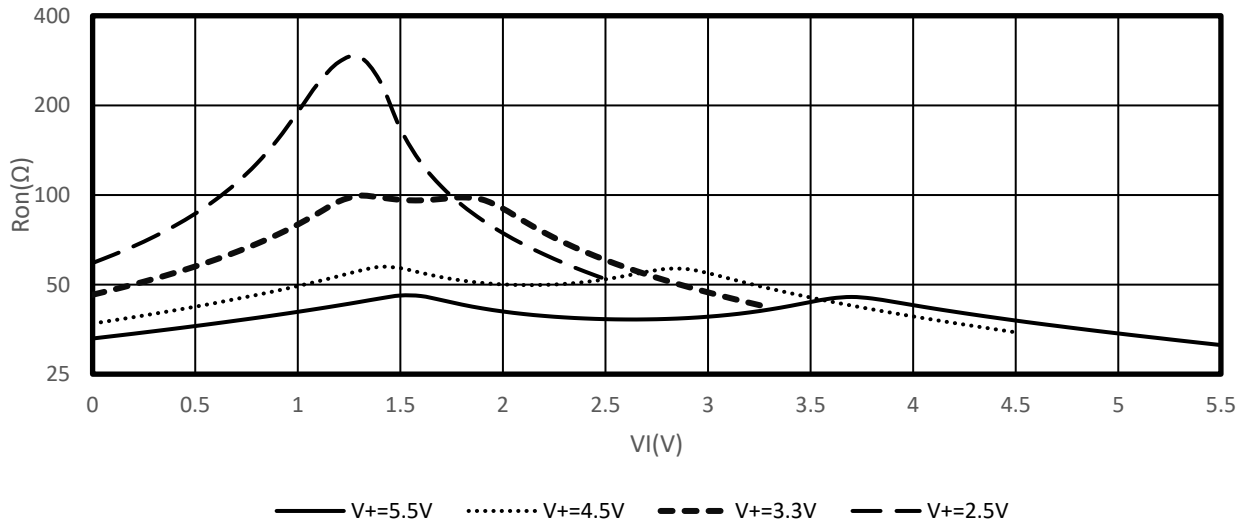

Parameter Measurement Information

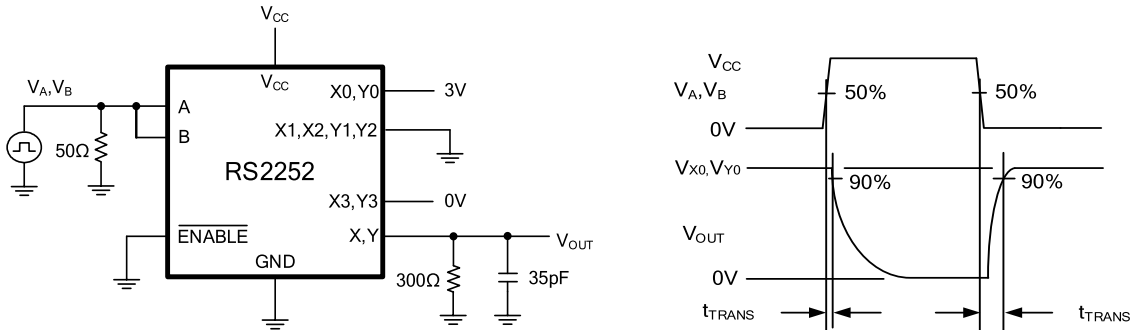

Test Circuit 1. Address Transition Times (t_{TRANS})

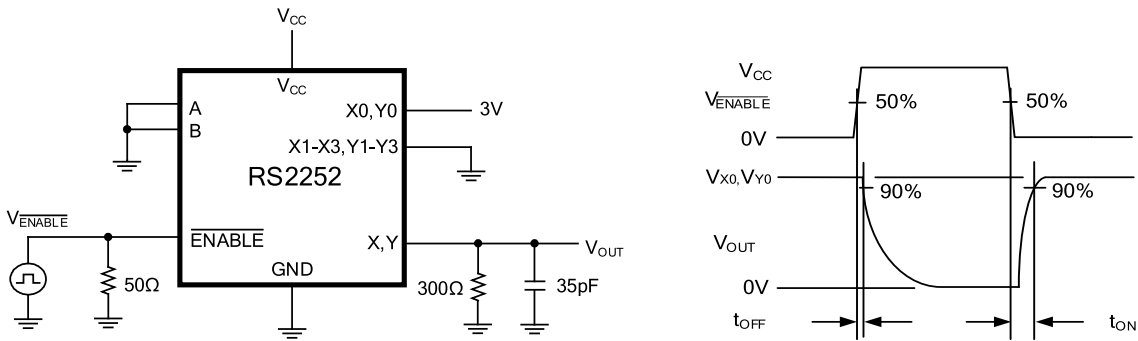

Test Circuit 2. Switching Times (t_{ON} , t_{OFF})

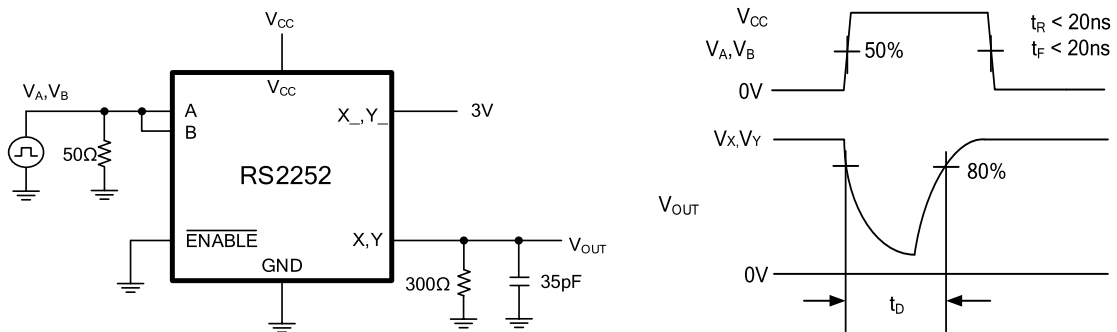

Test Circuit 3. Break-Before-Make Time Delay (t_d)

Parameter Measurement Information (continued)

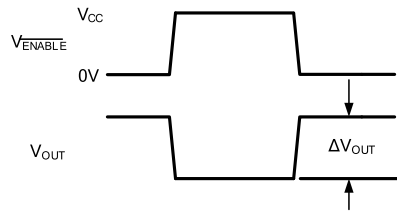
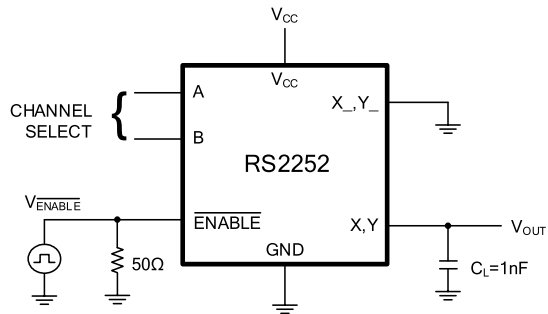

ΔV_{OUT} IS THE MEASURED VOLTAGE DUE TO CHARGE TRANSFER ERROR Q WHEN THE CHANNEL TURNS OFF
 $Q = \Delta V_{OUT} \times C_L$

Test Circuit 4. Charge Injection (Q)

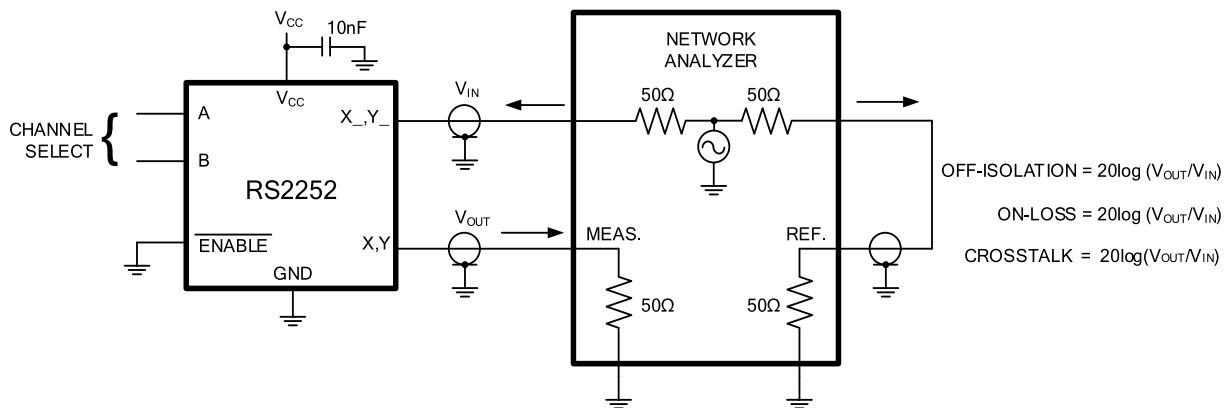

MEASUREMENTS ARE STANDARDIZED AGAINST SHORT AT SOCKET TERMINALS.
 OFF-ISOLATION IS MEASURED BETWEEN COM AND "OFF" NO TERMINAL ON EACH SWITCH.
 ON-LOSS IS MEASURED BETWEEN COM AND "ON" NO TERMINAL ON EACH SWITCH.
 SIGNAL DIRECTION THROUGH SWITCH IS REVERSED; WORST VALUES ARE RECORDED.

Test Circuit 5. Off Isolation, On Loss

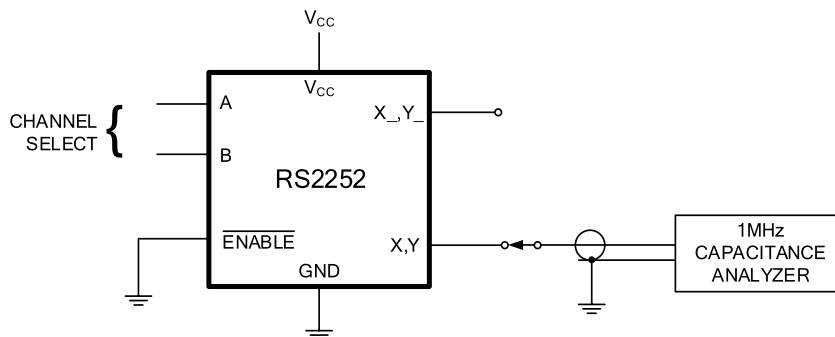

Test Circuit 6. Capacitance

APPLICATION NOTES

The RS2252 device is a differential 4-channel multiplexer having two binary control inputs, A and B, and an inhibit input. The two binary input signals select 1 of 4 pairs of channels to be turned on and connect the analog inputs to the outputs.

One application of the RS2252 is to use it in conjunction with a microcontroller to poll a keypad. Figure 1 shows the basic schematic for such a polling system. The microcontroller uses the channel select pins to cycle through the different channels while reading the input to see if a user is pressing any of the keys. This is a very robust setup, allowing for multiple simultaneous key-presses with very little power consumption. It also utilizes very few pins on the microcontroller. The down side of polling is that the microcontroller must continually scan the keys for a press and can do little else during this process.

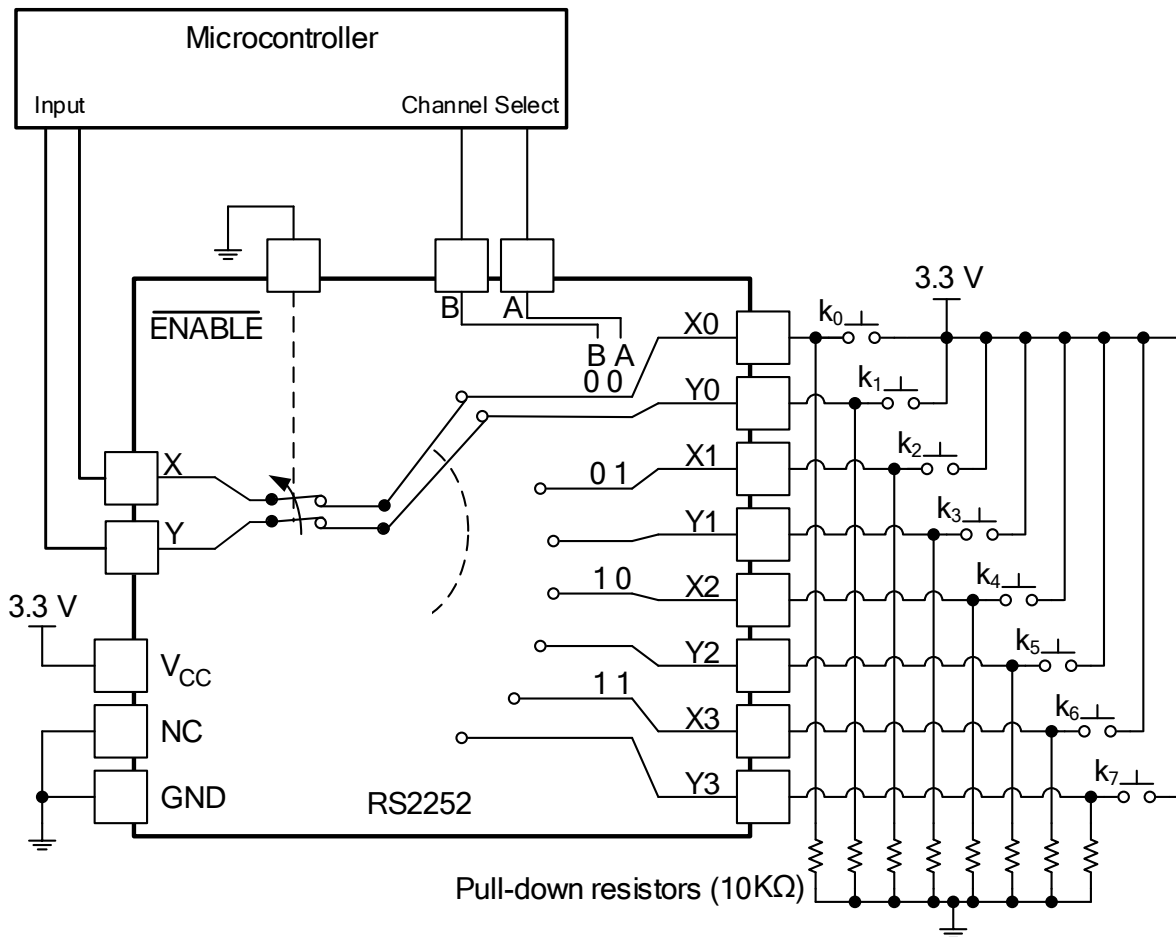
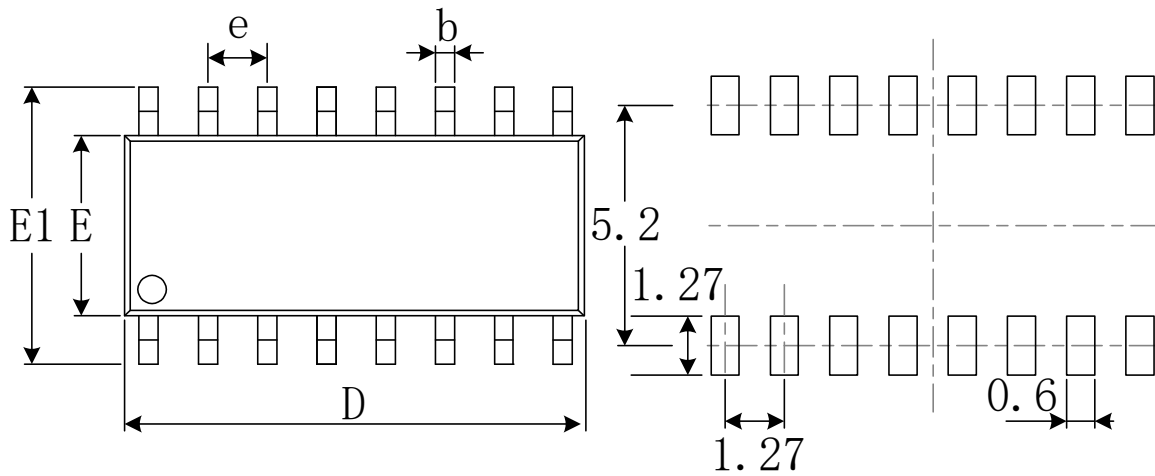

Figure 1. The RS2252 Being Used to Help Read Button Presses on a Keypad.

PACKAGE OUTLINE DIMENSIONS

SOIC-16



RECOMMENDED LAND PATTERN (Unit: mm)

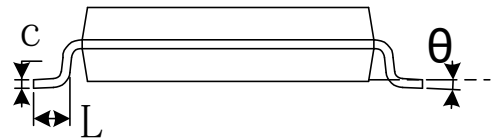
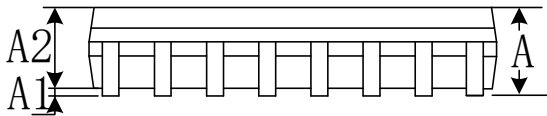

Symbol	Dimensions In Millimeters		Dimensions In Inches	
	Min	Max	Min	Max
A	1.350	1.750	0.053	0.069
A1	0.100	0.250	0.004	0.010
A2	1.350	1.550	0.053	0.061
b	0.330	0.510	0.013	0.020
c	0.170	0.250	0.006	0.010
D	9.800	10.200	0.386	0.402
E	3.800	4.000	0.150	0.157
E1	5.800	6.200	0.228	0.244
e	1.27(BSC)		0.050(BSC)	
L	0.400	1.270	0.016	0.050
θ	0°	8°	0°	8°

SSOP-16

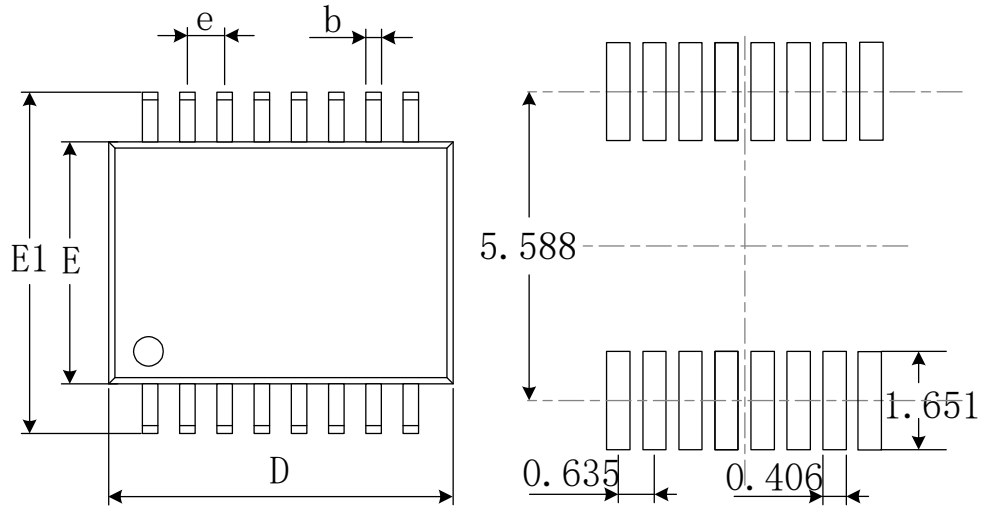

RECOMMENDED LAND PATTERN (Unit: mm)

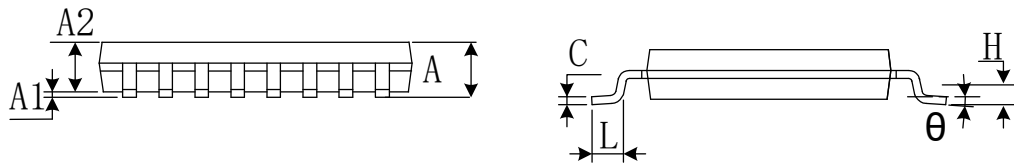

Symbol	Dimensions In Millimeters		Dimensions In Inches	
	Min	Max	Min	Max
A	1.350	1.750	0.053	0.069
A1	0.100	0.250	0.004	0.010
A2	1.350	1.550	0.053	0.061
b	0.200	0.300	0.008	0.012
c	0.170	0.250	0.007	0.010
D	4.700	5.100	0.185	0.200
E	3.800	4.000	0.150	0.157
E1	5.800	6.200	0.228	0.244
e	0.635(BSC)		0.025(BSC)	
L	0.400	1.270	0.016	0.050
θ	0°	8°	0°	8°

TSSOP-16

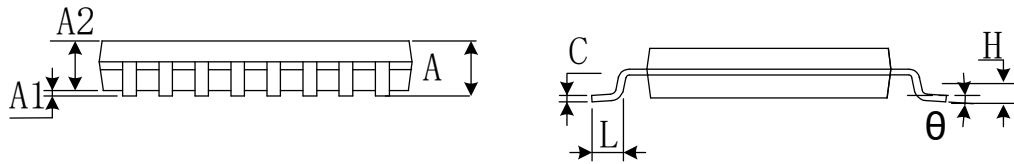
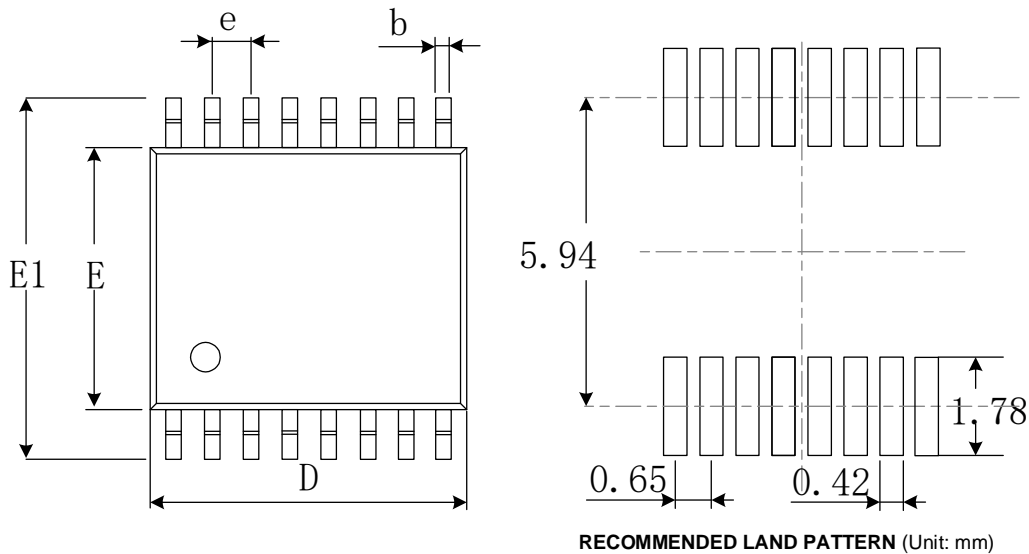

Symbol	Dimensions In Millimeters		Dimensions In Inches	
	Min	Max	Min	Max
A		1.200		0.047
A1	0.050	0.150	0.002	0.006
A2	0.800	1.050	0.031	0.041
b	0.190	0.300	0.007	0.012
c	0.090	0.200	0.004	0.008
D	4.860	5.100	0.191	0.201
E	4.300	4.500	0.169	0.177
E1	6.200	6.600	0.244	0.260
e	0.650(BSC)		0.026(BSC)	
L	0.500	0.700	0.02	0.028
H	0.25TYP		0.01TYP	
θ	1°	7°	1°	7°

QFN-3x3-16L

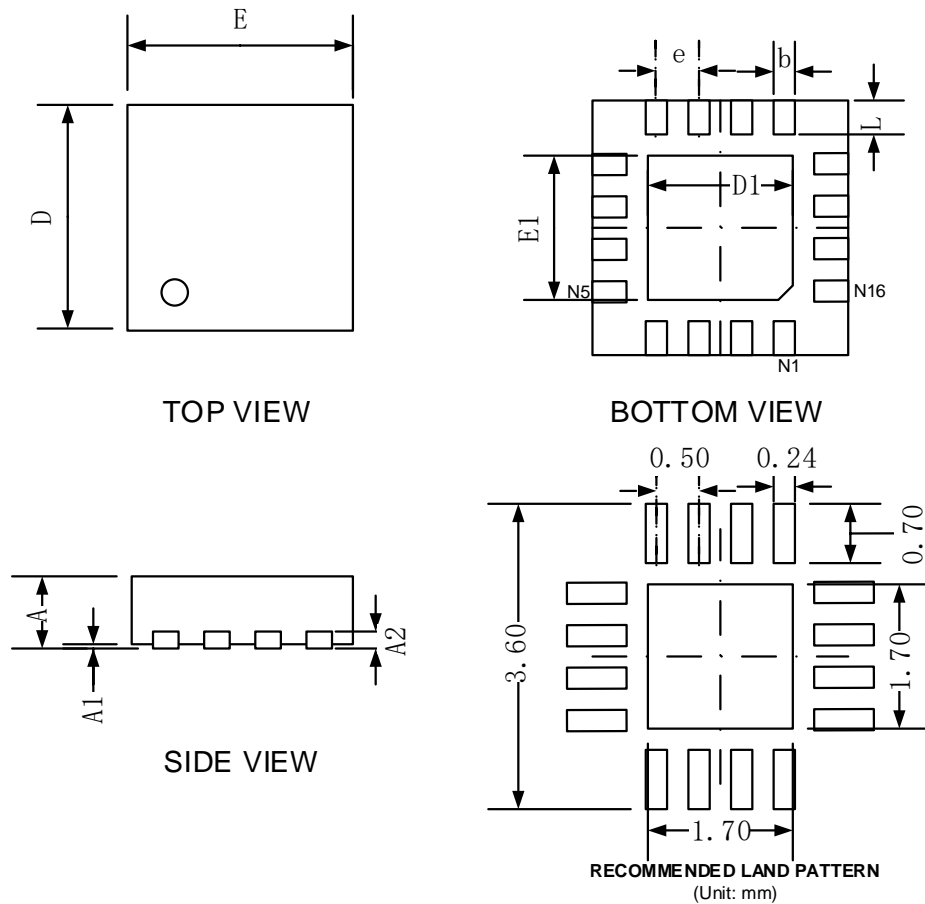

Symbol	Dimensions In Millimeters		Dimensions In Inches	
	Min	Max	Min	Max
A	0.700	0.800	0.028	0.031
A1	0.000	0.050	0.000	0.002
A2	0.203		0.008	
b	0.180	0.300	0.007	0.012
D	2.900	3.100	0.114	0.122
D1	1.600	1.800	0.063	0.071
E	2.900	3.100	0.114	0.122
E1	1.600	1.800	0.063	0.071
e	0.500 TYP		0.020 TYP	
L	0.300	0.500	0.012	0.020

X-ON Electronics

Largest Supplier of Electrical and Electronic Components

Click to view similar products for [Analogue Switch ICs category](#):

Click to view products by [RUNIC manufacturer](#):

Other Similar products are found below :

[FSA3051TMX](#) [NLAS4684FCTCG](#) [NLAS5223BLMNR2G](#) [NLVAS4599DTT1G](#) [NLX2G66DMUTCG](#) [425541DB](#) [425528R](#) [099044FB](#)
[MAX4762ETB+](#) [NLAS5123MNR2G](#) [PI5A4157CEX](#) [PI5A4599BCEX](#) [NLAS4717EPFCT1G](#) [PI5A3167CCEX](#) [SLAS3158MNR2G](#)
[PI5A392AQEX](#) [PI5A392AQE](#) [FSA634UCX](#) [NX3L1T5157GMZ](#) [ADG714BCPZ-REEL7](#) [HT4051ARZ](#) [TC4066BP\(N,F\)](#) [DG302BDJ-E3](#)
[ADG854BCPZ-REEL7](#) [PI5A100WE](#) [PI5A100QEX](#) [HV2733FG-G](#) [HV2701FG-G](#) [HV2301FG-G](#) [HV2301FG-G-M931](#) [RS2117YUTQK10](#)
[RS2118YUTQK10](#) [RS2227XUTQK10](#) [ADG452BRZ-REEL7](#) [MAX391CPE+](#) [MAX4744ELB+](#) [MAX4730EXT+T](#) [MAX4730ELT+](#)
[MAX333AEWP+](#) [BU4066BC](#) [MAX313CPE+](#) [BU4S66G2-TR](#) [NLASB3157MTR2G](#) [NX3L4684TK,115](#) [NX5L2750CGUX](#)
[NLAS4157DFT2G](#) [NLAS4599DFT2G](#) [NLASB3157DFT2G](#) [NLAST4599DFT2G](#) [NLAST4599DTT1G](#)