

CMOS 4-Channel Analog Multiplexer/Demultiplexer

FEATURES

- -3dB Bandwidth: 180MHz
- Single Supply Operation +2.5V to +5.5V
- Low ON Resistance, 24Ω(TYP) With 5V Supply
- High Off-Isolation: -83dB (RL = 50Ω, f = 1MHz)
- Break-Before-Make Switching
- Binary Address Decoding on Chip
- Operating Temperature Range: -40°C to +125°C
- PACKAGES: MSOP-10

DESCRIPTION

The RS2255 is a CMOS analog IC configured as 4-channel multiplexers. This CMOS device can operate from 2.5 V to 5.5 V.

The RS2255 device are digitally-controlled analog switches. It has low on-resistance (24Ω TYP) and very low off-leakage current (1nA TYP).

The RS2255 is available in Green MSOP-10 packages. It operates over an ambient temperature range of -40°C to +125°C.

APPLICATIONS

- Sensors
- Analog and Digital Multiplexing and Demultiplexing
- A/D and D/A Conversion
- Signal Gating
- Battery-Operated Equipment
- Factory Automation
- Appliances
- Communications Circuits

Functional Diagrams of RS2255

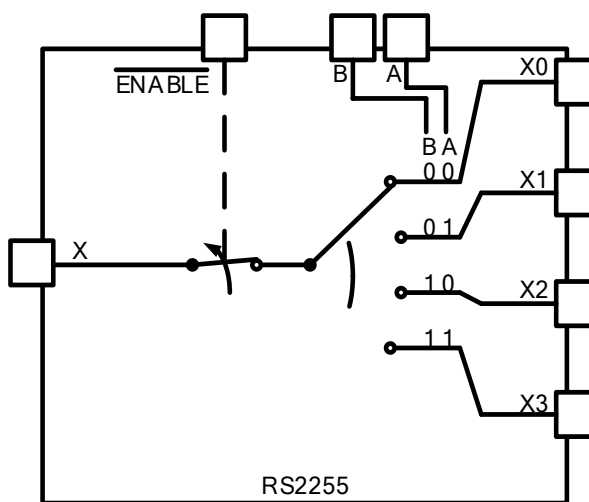

PIN CONFIGURATIONS

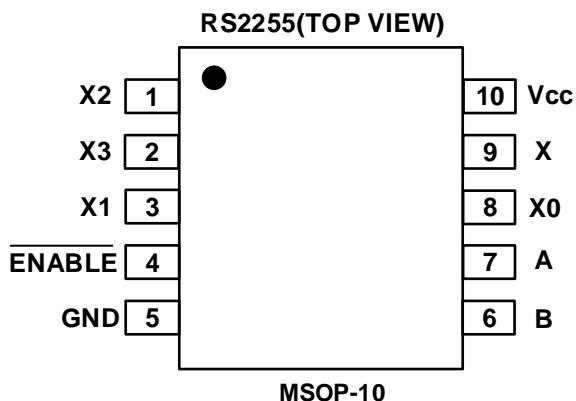

PIN DESCRIPTION

NAME	PIN	FUNCTION
X2	1	Analog Switch Normally Open Inputs 2.
X3	2	Analog Switch Normally Open Inputs 3.
X1	3	Analog Switch Normally Open Inputs 1.
$\overline{\text{ENABLE}}$	4	Inhibit. Drive $\overline{\text{ENABLE}}$ low or connect to GND for normal operation. Drive ENABLE high or connect to Vcc to turn all switches off.
GND	5	Ground.
B	6	Digital Address "B" Input.
A	7	Digital Address "A" Input.
X0	8	Analog Switch Normally Open Inputs 0.
X	9	Analog Switch Common.
Vcc	10	Positive Analog and Digital Supply Voltage.

FUNCTION TABLE

$\overline{\text{ENABLE}}$ INPUT	INPUT STATES		ON CHANNEL(S)
	B	A	
1	X	X	NONE
0	0	0	X0
0	0	1	X1
0	1	0	X2
0	1	1	X3

X=Don't care
NOTE: Input and output pins are identical and interchangeable. Either may be considered an input or output; signals pass equally well in either direction.



SPECIFICATIONS

Absolute Maximum Ratings

Over operating free-air temperature range (unless otherwise noted) ⁽¹⁾

SYMBOL	PARAMETER		MIN	MAX	UNIT
V _{CC}	Supply Voltage		-0.3	6	V
V _{IN}	Input Voltage (All inputs)		-0.3	V _{CC} +0.3	
I _{IN}	Switch Input Current	Any one input	-20	+20	mA
I _{PEAK}	Peak Switch Current	Pulsed at 1ms Duration, <10% Duty Cycle	-40	+40	
T _J	Junction Temperature			150	°C
T _{stg}	Storage temperature		-65	+150	

(1) Stresses above these ratings may cause permanent damage. Exposure to absolute maximum conditions for extended periods may degrade device reliability. These are stress ratings only, and functional operation of the device at these or any other conditions beyond those specified is not implied.

ESD Ratings

			VALUE	UNIT
V _(ESD)	Electrostatic discharge	Human-body model (HBM)	±4500	V
		Charged device model (CDM)	±1500	V

Recommended Operating Conditions

Over operating free-air temperature range (unless otherwise noted)

SYMBOL	PARAMETER	MIN	MAX	UNIT
V _{CC}	Supply Voltage	2.5	5.5	V
T _A	Operating temperature	-40	+125	°C

Thermal Information

THERMAL METRIC		RS2255	UNIT
		10 PINS	
		MSOP-10	
R _{θJA}	Junction-to-ambient thermal resistance	180.7	°C/W
R _{θJC(top)}	Junction-to-case(top) thermal resistance	66.2	°C/W
R _{θJB}	Junction-to-board thermal resistance	103.2	°C/W
Ψ _{JT}	Junction-to-top characterization parameter	11.2	°C/W
Ψ _{JB}	Junction-to-board characterization parameter	101.3	°C/W
R _{θJC(bot)}	Junction-to-case(bottom) thermal resistance	N/A	°C/W



PACKAGE/ORDERING INFORMATION

PRODUCT	ORDERING NUMBER	TEMPERATURE RANGE	PACKAGE LEAD	PACKAGE MARKING	PACKAGE OPTION
RS2255	RS2255XN	-40°C ~+125°C	MSOP-10	RS2255	Tape and Reel,3000



ELECTRICAL CHARACTERISTICS

$V_{CC} = 5.0\text{ V}$ or 3.3 V , FULL = -40°C to $+125^{\circ}\text{C}$, Typical values are at $T_A = +25^{\circ}\text{C}$. (unless otherwise noted)

PARAMETER	SYMBOL	CONDITIONS	V_{CC}	T_A	MIN	TYP	MAX	UNITS
ANALOG SWITCH								
Analog Signal Range	$V_{X_}, V_X$			FULL	0		V_{CC}	V
On-Resistance	R_{ON}	$V_{CC}=5\text{V}, I_X=1\text{mA}$	5V	+25°C		24	30	Ω
				FULL			35	Ω
		$V_{CC}=3.3\text{V}, I_X=1\text{mA}$	3.3V	+25°C		50	60	Ω
				FULL			65	Ω
On-Resistance Match Between Channels	ΔR_{ON}	$V_{CC}=5\text{V}, I_X=1\text{mA}$ Switch ON	5V	+25°C		1	4	Ω
				FULL			5.3	Ω
On-Resistance Flatness	$R_{FLAT(ON)}$	$V_{CC}=5\text{V}, I_X=1\text{mA}$ Switch ON	5V	+25°C		8	11	Ω
				FULL			14	Ω
X_ Off, X Off, X On, Leakage Current	$I_{X(OFF)}, I_{X(OFF)}, I_{X(ON)}$	$V_{CC}=5\text{V}, V_{X_}=1\text{V}, 4.5\text{V}$ $V_X=4.5\text{V}, 1\text{V}$	5V	+25°C		1	100	nA
		$V_{CC}=3.3\text{V}, V_{X_}=1\text{V}, 3\text{V}$ $V_X=3\text{V}, 1\text{V}$	3.3V	+25°C		1	100	nA
DIGITAL CONTROL INPUTS⁽¹⁾								
Logic Input Logic Threshold High	$V_{AH}, V_{BH}, V_{ENABLE}$		5V	+25°C	1.7			V
			3.3V	+25°C	1.7			V
Logic Input Logic Threshold Low	$V_{AL}, V_{BL}, V_{ENABLE}$		5V	+25°C			0.5	V
			3.3V	+25°C			0.5	V
Input-Current High	$I_{AH}, I_{BH}, I_{ENABLE}$	$V_A, V_B, V_{ENABLE} = V_{CC}$	3.3V to 5V	+25°C		1	100	nA
Input-Current Low	$I_{AL}, I_{BL}, I_{ENABLE}$	$V_A, V_B, V_{ENABLE} = 0\text{V}$	3.3V to 5V	+25°C		1	100	nA

(1) All unused digital inputs of the device must be held at V_{IO} or GND to ensure proper device operation.



ELECTRICAL CHARACTERISTICS (continued)

V_{CC} = 5.0 V or 3.3V, FULL = -40°C to $+125^{\circ}\text{C}$ Typical values are at $T_A = +25^{\circ}\text{C}$ (unless otherwise noted)

PARAMETER	SYMBOL	CONDITIONS	V_{CC}	TEMP	MIN	TYP	MAX	UNITS
DYNAMIC CHARACTERISTICS								
Address Transition Time	t_{TRANS}	$V_X = 3\text{V}/0\text{V}$, $R_L = 300\Omega$, $C_L = 35\text{pF}$, Test Circuit 1	5V	$+25^{\circ}\text{C}$		160		ns
		$V_X = 3\text{V}/0\text{V}$, $R_L = 300\Omega$, $C_L = 35\text{pF}$, Test Circuit 1	3.3V	$+25^{\circ}\text{C}$		240		ns
$\overline{\text{ENABLE}}$ Turn-On Time	t_{ON}	$V_X = 3\text{V}$, $R_L = 300\Omega$, $C_L = 35\text{pF}$, Test Circuit 2	5V 3.3V	$+25^{\circ}\text{C}$		90 140		ns
$\overline{\text{ENABLE}}$ Turn-Off Time	t_{OFF}	$V_X = 3\text{V}$, $R_L = 300\Omega$, $C_L = 35\text{pF}$, Test Circuit 2	5V 3.3V	$+25^{\circ}\text{C}$		70 100		ns
Internal A, B, C Rise Time	t_R		5V	$+25^{\circ}\text{C}$		50		ns
			3.3V			80		
Internal A, B, C Fall Time	t_F		5V	$+25^{\circ}\text{C}$		60		ns
			3.3V			85	ns	
Break-Before-Make Time Delay	t_D	$V_X = 3\text{V}$, $R_L = 300\Omega$, $C_L = 35\text{pF}$, Test Circuit 3	5V	$+25^{\circ}\text{C}$		50		ns
			3.3V			80	ns	
Charge Injection	Q	$R_S = 0\Omega$, $C_L = 1\text{nF}$, Test Circuit 4	5V	$+25^{\circ}\text{C}$		6		pC
			3.3V			4	pC	
Crosstalk	X_{TALK}	$f = 1\text{MHz}$, Test Circuit 5	5V	$+25^{\circ}\text{C}$		-110		dB
Off Isolation	O_{ISO}	$R_L = 50\Omega$, $f = 1\text{MHz}$, Test Circuit 5	5V	$+25^{\circ}\text{C}$		-83		dB
-3dB Bandwidth	BW	$R_L = 50\Omega$	5V	$+25^{\circ}\text{C}$		180		MHz
			3.3V			180	MHz	
Input Off-Capacitance	$C_{X(OFF)}$	$f = 1\text{MHz}$, Test Circuit 6	5V	$+25^{\circ}\text{C}$		4.7		pF
Output Off-Capacitance	$C_{X(OFF)}$	$f = 1\text{MHz}$, Test Circuit 6	5V	$+25^{\circ}\text{C}$		12.7		pF
Output On- Capacitance	$C_{X(ON)}$	$f = 1\text{MHz}$, Test Circuit 6	5V	$+25^{\circ}\text{C}$		16		pF
Total Harmonic Distortion	THD	$R_L = 600\Omega$, 5V_{P-P} , $f = 20\text{Hz}$ to 20kHz	5V	$+25^{\circ}\text{C}$		0.7		%
POWER REQUIREMENTS								
Power Supply Range	V_{CC}			FULL	2.5		5.5	V
Power Supply Current	I_{CC}	$V_{CC} = 5.0\text{V}$, V_A , V_B , $V_{\overline{\text{ENABLE}}} = V_{CC}$ or 0	5V	$+25^{\circ}\text{C}$		0.001	2	μA
		$V_{CC} = 3.3\text{V}$, V_A , V_B , $V_{\overline{\text{ENABLE}}} = V_{CC}$ or 0	3.3V	$+25^{\circ}\text{C}$		0.001	1	μA

TYPICAL CHARACTERISTICS

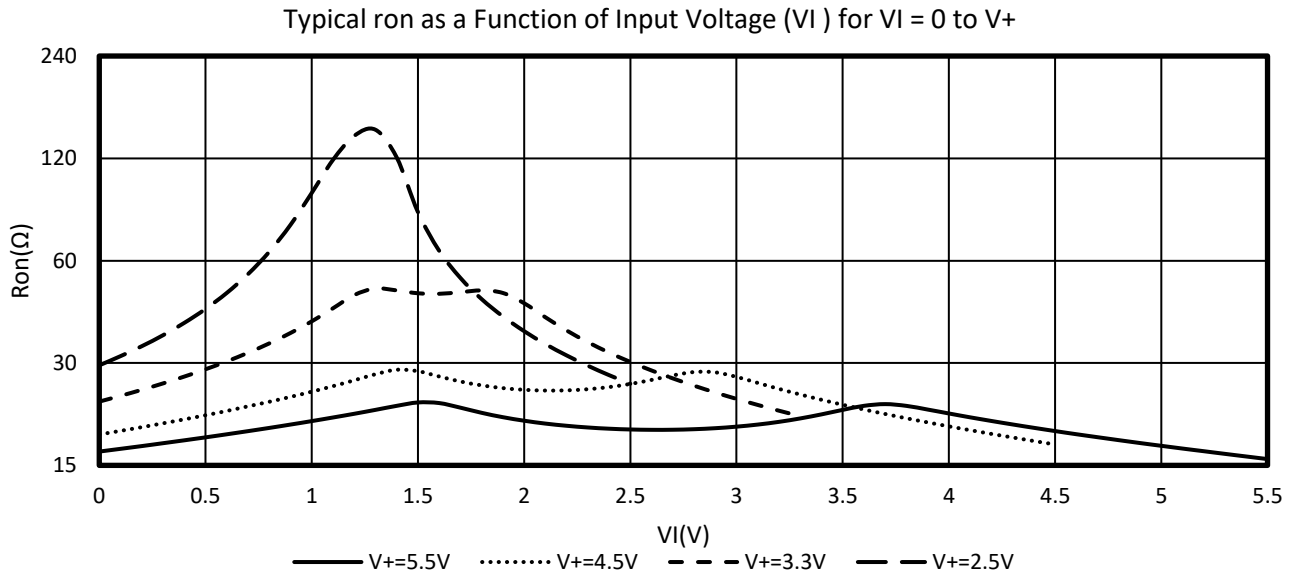

Parameter Measurement Information

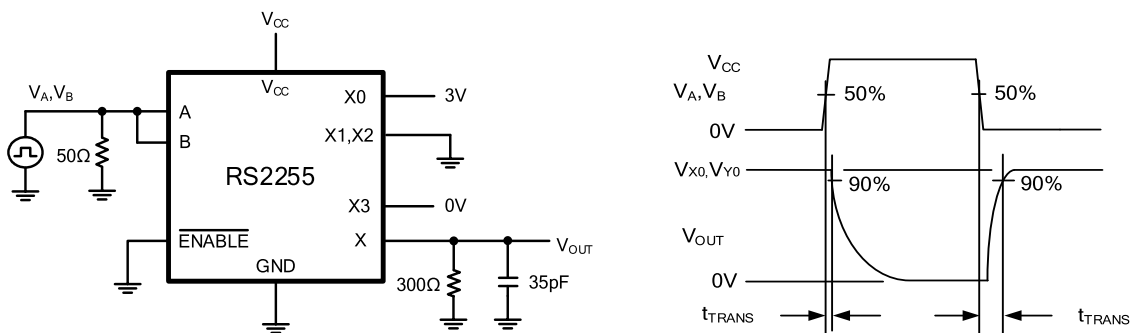

Test Circuit 1. Address Transition Times (t_{TRANS})

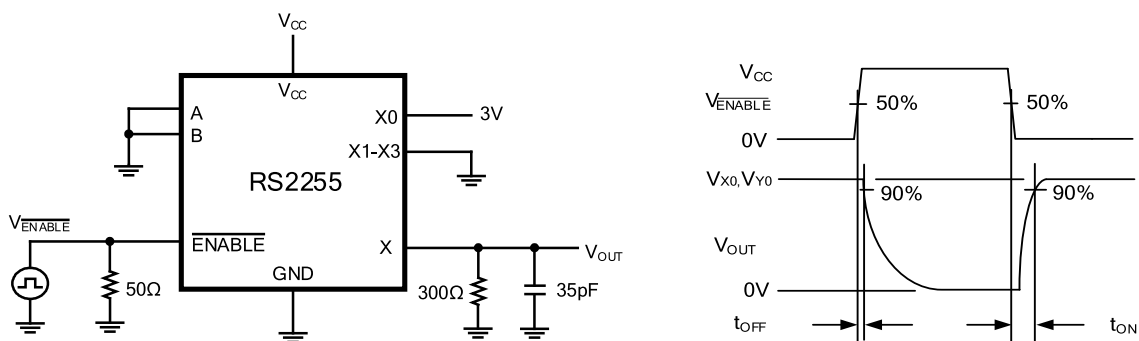

Test Circuit 2. Switching Times (t_{ON} , t_{OFF})

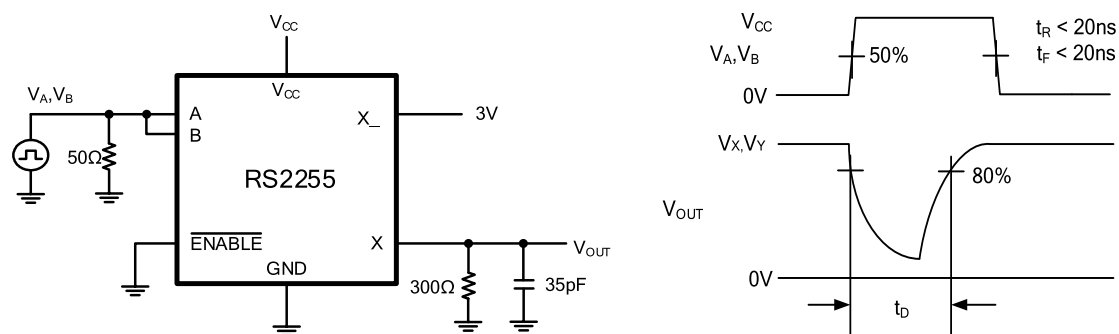

Test Circuit 3. Break-Before-Make Time Delay (t_D)

Parameter Measurement Information (continued)

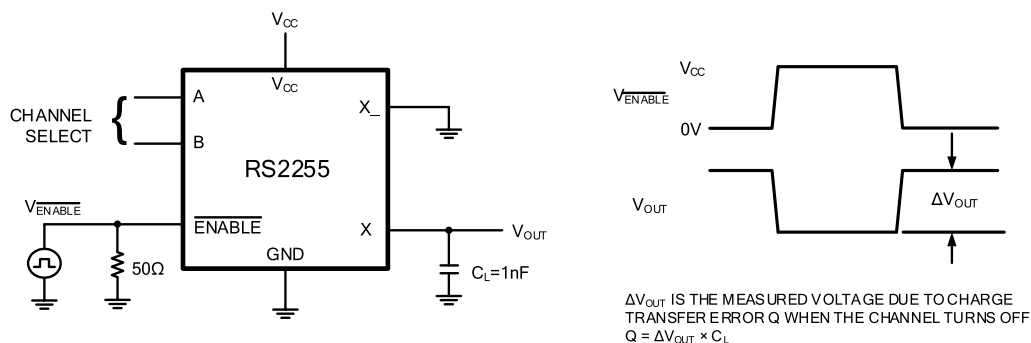

Test Circuit 4. Charge Injection (Q)

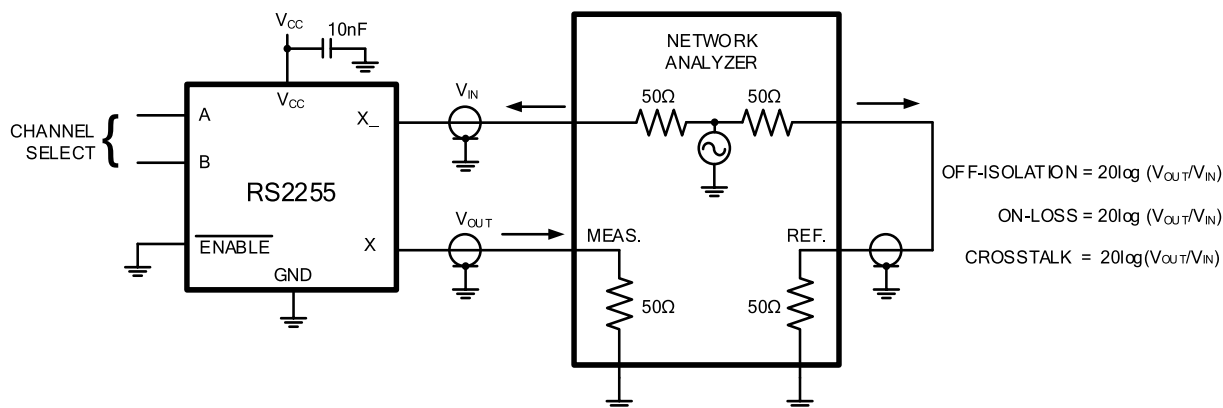

MEASUREMENTS ARE STANDARDIZED AGAINST SHORT AT SOCKET TERMINALS.
 OFF-ISOLATION IS MEASURED BETWEEN COM AND "OFF" NO TERMINAL ON EACH SWITCH.
 ON-LOSS IS MEASURED BETWEEN COM AND "ON" NO TERMINAL ON EACH SWITCH.
 SIGNAL DIRECTION THROUGH SWITCH IS REVERSED; WORST VALUES ARE RECORDED.

Test Circuit 5. Off Isolation, On Loss

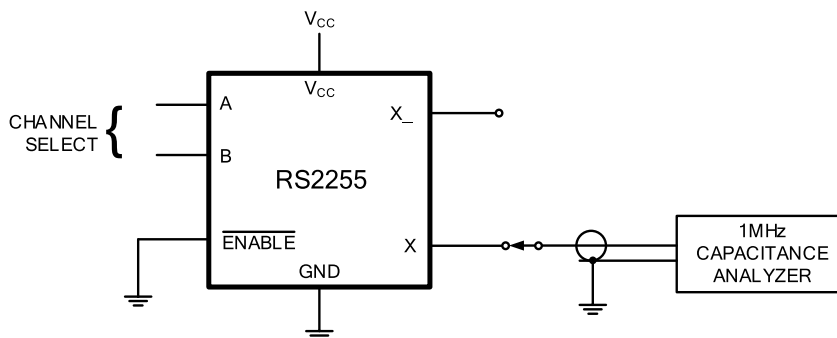

Test Circuit 6. Capacitance

PACKAGE OUTLINE DIMENSIONS MSOP-10

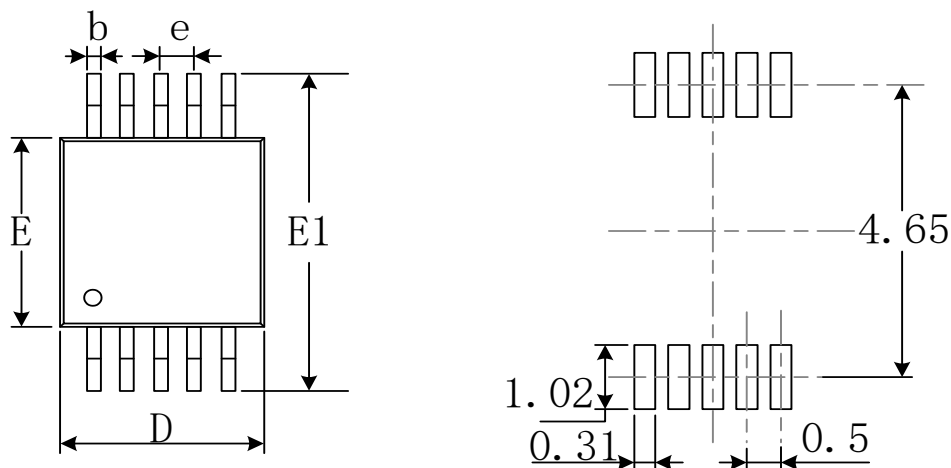

RECOMMENDED LAND PATTERN (Unit: mm)



Symbol	Dimensions In Millimeters		Dimensions In Inches	
	Min	Max	Min	Max
A	0.820	1.100	0.032	0.043
A1	0.020	0.150	0.001	0.006
A2	0.750	0.950	0.030	0.037
b	0.180	0.280	0.007	0.011
c	0.090	0.230	0.004	0.009
D	2.900	3.100	0.114	0.122
e	0.50(BSC)		0.020(BSC)	
E	2.900	3.100	0.114	0.122
E1	4.750	5.050	0.187	0.199
L	0.400	0.800	0.016	0.031
θ	0°	6°	0°	6°

X-ON Electronics

Largest Supplier of Electrical and Electronic Components

Click to view similar products for [Analogue Switch ICs category](#):

Click to view products by [RUSIC manufacturer](#):

Other Similar products are found below :

[FSA3051TMX](#) [NLVAS4599DTT1G](#) [MAX4992EVB+T](#) [MAX4684ETB+T](#) [BCM6522IPBG](#) [BCM65300IFSBG](#) [MAX14764ETA+T](#)
[TMUX1113RSVR](#) [TMUX1112RSVR](#) [ADG1436TRUZ-EP](#) [BL4684C](#) [PE423422A](#) [PE42359SCAA](#) [PE42540F](#) [RS550YUCM12](#)
[ADGS1414DBCCZ](#) [ADG658YRUZ-REEL7](#) [RS2117YUTQK10](#) [RS2118YUTQK10](#) [RS2227XUTQK10](#) [SP2526A-1EN-L/TR](#) [FSA4157P6X](#)
[BA7603F-E2](#) [MAX4702EUE+](#) [MAX4617CUE+](#) [MAX4599EUT+T](#) [MAX4066ESD+](#) [MAX4052ACSE+](#) [MAX396CAI+](#) [MAX391CPE+](#)
[MAX4730EXT+T](#) [MAX314CPE+](#) [MAX4051AEEE+](#) [BU4066BCFV-E2](#) [MAX313CPE+](#) [BU4S66G2-TR](#) [TS3A4751PWR](#)
[NCN1154MUTAG](#) [DG444DY-E3](#) [NLAS4157DFT2G](#) [NLAS4599DFT2G](#) [NLAS7242MUTBG](#) [NLASB3157DFT2G](#) [NLA4599DFT2G](#)
[NLA4599DTT1G](#) [DG403DY-T1-E3](#) [MAX4714EXTT](#) [MAX392CPE](#) [BGSX22G2A10E6327XTSA1](#) [ADG1611BRUZ-REEL7](#)