

# 4PST Depletion Mode Isolation Switch

## FEATURES

- 4PST(NC)
- Depletion Mode MOSFETs
- Audio Frequency Range
- Supply Range: +1.6V to +3.0V
- Low ON-State Resistance:0.5Ω (TYP)
- R<sub>ON</sub> Flat: 0.01 Ω Typical
- THD+N: 0.002% Typical
- Extended Industrial Temperature Range: -40°C to +85°C
- Available in Green WLCSP12 and QFN2.5\*2.5-12 Package

## APPLICATIONS

- MP3 Portable Media Players
- Cell Phones

## DESCRIPTION

The RS550 is a high-performance four-pole single throw(4PST) normally closed Depletion-Mode isolation switch. The Depletion Mode technology allows the device to conduct signals when there is no V<sub>CC</sub> available and to isolate the signals when V<sub>CC</sub> is present. The RS550 operates on a wide V<sub>CC</sub> range for design flexibility. Additionally, select pins allow the internal oscillator frequency to be adjusted between 500 kHz and 750 kHz in 75 kHz steps when V<sub>CC</sub> is present. This feature is used to shift the electromagnetic interference (EMI) signature to meet customer specifications.

## Typical Application Circuit

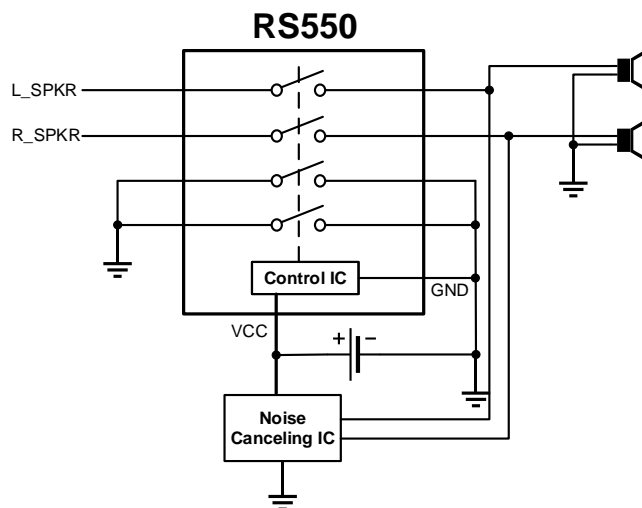

## PIN CONFIGURATIONS

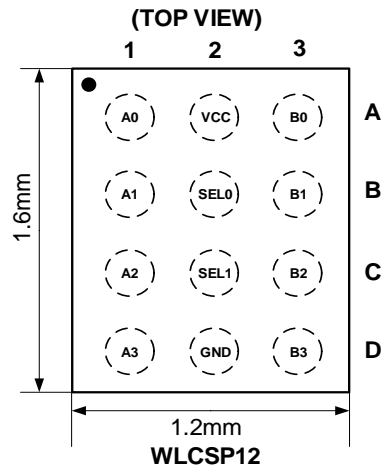

## PIN DESCRIPTION

PIN#	NAME	TYPE	DESCRIPTION
A1	A0	I/O	A-Port
B1	A1	I/O	A-Port
C1	A2	I/O	A-Port
D1	A3	I/O	A-Port
A2	VCC	P	Supply Voltage (see Table 1)
B2	SEL0	I	Oscillator Frequency Control (see Table 2). Used to shift the electromagnetic interference (EMI) signature to meet the customer specifications.
C2	SEL1	I	
D2	GND	G	Ground
A3	B0	I/O	B-Port
B3	B1	I/O	B-Port
C3	B2	I/O	B-Port
D3	B3	I/O	B-Port

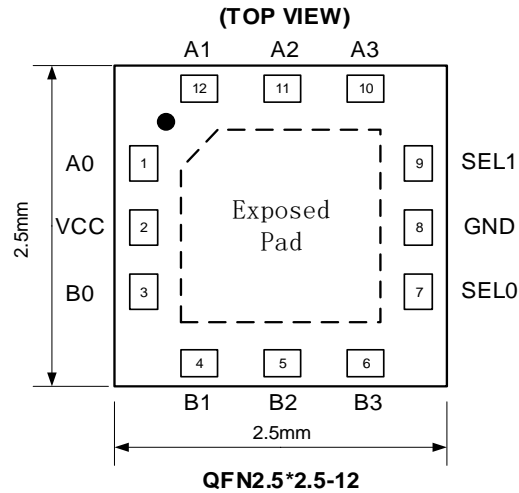

### PIN DESCRIPTION

PIN#	NAME	TYPE	DESCRIPTION
1	A0	I/O	A-Port
2	VCC	P	Supply Voltage (see Table 1)
3	B0	I/O	B-Port
4	B1	I/O	B-Port
5	B2	I/O	B-Port
6	B3	I/O	B-Port
7	SEL0	I	Oscillator Frequency Control (see Table 2). Used to shift the electromagnetic interference (EMI) signature to meet the customer specifications.
9	SEL1	I	
8	GND	G	Ground
10	A3	I/O	A-Port
11	A2	I/O	A-Port
12	A1	I/O	A-Port
--	Exposed Pad	G	Ground or float

**Table 1. Truth Table**

V <sub>CC</sub>	Function
0V~0.2V	Conduction; B0~B3=A0~A3
1.6V~3.0V	Disconnect; B0~B3≠A0~A3

**Table 2. Oscillator Frequency Step Logic**

SEL1	SEL0	Frequency (TYP)
LOW	LOW	500kHz
LOW	HIGH	575kHz
HIGH	LOW	650kHz
HIGH	HIGH	725kHz



## SPECIFICATIONS

### Absolute Maximum Ratings

Over operating free-air temperature range (unless otherwise noted) <sup>(1)</sup>

SYMBOL	PARAMETER		MIN	MAX	UNIT
V <sub>CC</sub>	Supply/Control Voltage,		0	5.5	V
V <sub>IN</sub>	Input Voltage (Select Pins SEL0, SEL1)		0	V <sub>CC</sub>	
V <sub>SW(ON)</sub>	DC Switch I/O Voltage (Switch Conducting)	V <sub>CC</sub> =0V	-5.0	+5.0	
V <sub>SW(OFF)</sub> <sup>(2)</sup>	DC Switch I/O Voltage (Switch Isolated)	V <sub>CC</sub> =Powered	-1.8	+3.0	
I <sub>IK</sub>	DC Input Diode Current		-50		mA
I <sub>SW</sub>	Switch I/O Current	V <sub>CC</sub> =0V		350	
I <sub>SWPEAK</sub>	Peak Switch Current	Pulsed at 1ms Duration, <10% Duty Cycle		500	
T <sub>A</sub>	Absolute Maximum Operating Temperature		-40	+85	°C
T <sub>stg</sub>	Storage		-60	+150	

(1) Stresses above these ratings may cause permanent damage. Exposure to absolute maximum conditions for extended periods may degrade device reliability. These are stress ratings only, and functional operation of the device at these or any other conditions beyond those specified is not implied.

(2) When a switch is isolated (OFF), V<sub>SW</sub> value must be < V<sub>CC</sub>.

### ESD Ratings

			VALUE	UNIT
V <sub>(ESD)</sub>	Electrostatic discharge	Human-body model (HBM)	±4000	V
		Machine Model (MM)	200	

### Recommended Operating Conditions

Over operating free-air temperature range (unless otherwise noted) <sup>(3)</sup>

SYMBOL	PARAMETER		MIN	MAX	UNIT
V <sub>CC(ON)</sub>	Supply Voltage with Switch Conducting		0	0.2	V
V <sub>CC(OFF)</sub>	Supply Voltage with Switch Isolated		1.6	3.0	V
V <sub>SW(ON)</sub>	DC Switch I/O Voltage (Switch Conducting)	V <sub>CC</sub> =0V	-2.0	2.0	V
V <sub>SW(OFF)</sub>	DC Switch I/O Voltage (Switch Isolated)	V <sub>CC</sub> =1.6V to 3.0V	-1.6	+1.6	V

(3) The Recommended Operating Condition table defines the conditions for actual device operation. Recommended operating condition are specified to ensure optimal performance to the datasheet specifications. Fairchild does not recommend exceeding them or designing to Absolute Maximum Ratings.



## PACKAGE/ORDERING INFORMATION

PRODUCT	ORDERING NUMBER	TEMPERATURE RANGE	PACKAGE LEAD	PACKAGE MARKING	PACKAGE OPTION
RS550	RS550YUCM12	-40°C ~+85°C	WLCSP12	RS550 XXXX	Tape and Reel,3000
RS550	RS550YUTQG12	-40°C ~+85°C	QFN2.5*2.5-12	RS550 XXXX	Tape and Reel,3000

NOTE: XXXX = Date Code and Vendor Code.



## ELECTRICAL CHARACTERISTICS

Typical values at  $T_A = 25^\circ\text{C}$  unless otherwise specified.

PARAMETER	SYMBOL	CONDITIONS	V <sub>CC</sub> (V)	T <sub>A</sub>	MIN	TYP	MAX	UNITS
<b>DC Electrical Characteristics</b>								
Switch-to-GND Leakage Current (Switch Conducting)	I <sub>ON</sub>	A <sub>n</sub> = -1.4 V to 1.4 V, B <sub>n</sub> = Float	0	+25°C	0	0.3	2.0	μA
Switch-to-GND Leakage Current (Switch Isolated)	I <sub>OFF</sub>	A <sub>n</sub> = 0.4 V to 1.4 V, B <sub>n</sub> = Float	3	+25°C	0	0.5	1.0	μA
Switch On Resistance <sup>(4)</sup>	R <sub>ON</sub>	I <sub>SW</sub> = ±24 mA, V <sub>SW</sub> = -1.4V to +1.4V	0	+25°C		0.5		Ω
On Resistance Flatness <sup>(4)</sup>	R <sub>FLAT(ON)</sub>	I <sub>SW</sub> = ±24 mA, V <sub>SW</sub> = -1.4V to +1.4V	0	+25°C		0.01		Ω
Quiescent Supply Current	I <sub>CC</sub>	SEL0 = SEL1 = V <sub>CC</sub>	3	+25°C	0	40	60	μA
Input Voltage High (Select Pins) <sup>(5)</sup>	V <sub>IH</sub>		3	+25°C	0.8*V <sub>CC</sub>			V
Input Voltage Low (Select Pins) <sup>(5)</sup>	V <sub>IL</sub>		3	+25°C			0.2*V <sub>CC</sub>	V
Input Leakage Current (Select Pins)	I <sub>IN</sub>		3	+25°C	0		±1	μA
<b>AC Electrical Characteristics</b>								
Turn-On Time V <sub>CC</sub> to Output <sup>(6,7)</sup>	t <sub>ON</sub>	R <sub>L</sub> = 32 Ω, C <sub>L</sub> = 10pF, V <sub>SW</sub> = 1.4V	1.6	+25°C		160		ns
Turn-Off Time V <sub>CC</sub> to Output <sup>(6,7)</sup>	t <sub>OFF</sub>	R <sub>L</sub> = 32 Ω, C <sub>L</sub> = 10pF, V <sub>SW</sub> = 1.4V	1.6	+25°C		90		μs
Off Isolation <sup>(6,7)</sup>	O <sub>IRR</sub>	R <sub>L</sub> = 32 Ω, f = 20 kHz, V <sub>SW</sub> = 0.35 V <sub>RMS</sub>	1.6	+25°C		-80		dB
Crosstalk <sup>(6,7)</sup>	X <sub>TALK</sub>	R <sub>L</sub> = 32 Ω, f = 20 kHz, V <sub>SW</sub> = 1 V <sub>RMS</sub>	0	+25°C		-90		dB
-3dB Bandwidth <sup>(6)</sup>	BW	R <sub>L</sub> = 50 Ω, C <sub>L</sub> = 0 pF	0	+25°C		<200		MHZ
Total Harmonic Distortion + Noise <sup>(6,7)</sup>	THD+N	R <sub>L</sub> = 32 Ω, f = 20 Hz to 20 kHz, V <sub>SW</sub> = 1 V <sub>RMS</sub>	0	+25°C		0.002		%

(4) Guaranteed by test and characterization.

(5) Voltages on select control pins must be <V<sub>CC</sub>.

(6) SEL0=SEL1=LOW.

(7) Guaranteed by characterization.

## PACKAGE OUTLINE DIMENSIONS WLCSP12

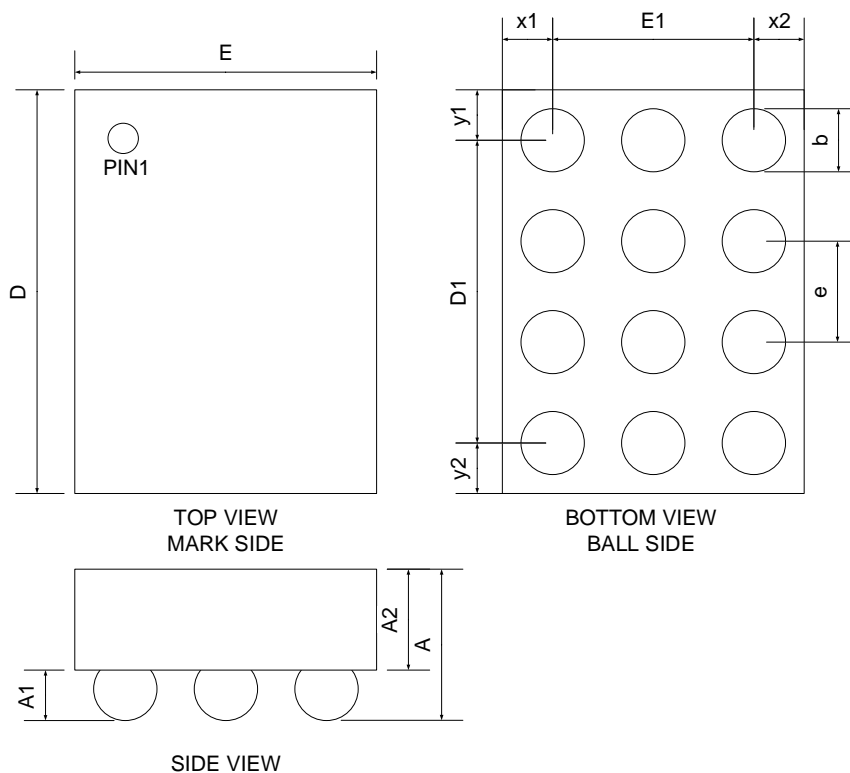

NOTES: ALL WAFER ORIENTATION NOTCH DOWN

SYMBOL	Dimensions In Millimeters			Dimensions In Inches		
	MIN	NOM	MAX	MIN	NOM	MAX
A	0.542	0.582	0.622	0.021	0.023	0.024
A1	0.177	0.202	0.227	0.007	0.008	0.009
A2	0.355	0.380	0.405	0.014	0.015	0.016
D	1.540	1.570	1.600	0.061	0.062	0.063
D1	1.200BSC			0.047BSC		
E	1.140	1.170	1.200	0.045	0.046	0.047
E1	0.800BSC			0.031BSC		
b	0.243	0.268	0.293	0.010	0.011	0.012
e	0.400BSC			0.016BSC		
x1	0.185 REF			0.007REF		
x2	0.185 REF			0.007REF		
y1	0.185 REF			0.007REF		
y2	0.185 REF			0.007REF		

## QFN2.5\*2.5-12

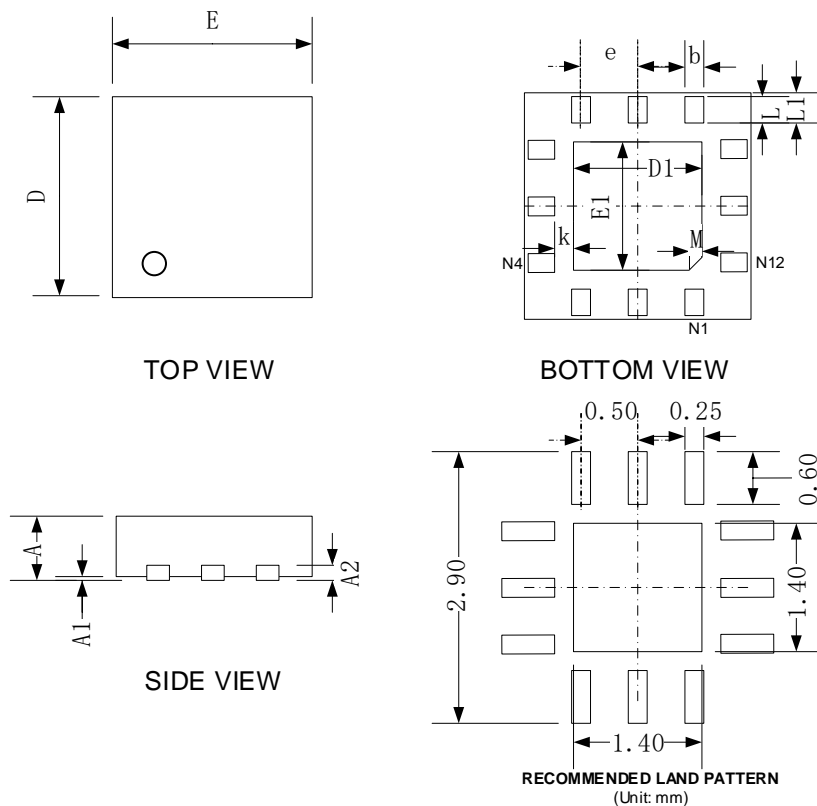

SYMBOL	Dimensions In Millimeters			Dimensions In Inches		
	MIN	NOM	MAX	MIN	NOM	MAX
A	0.50	0.55	0.60	0.020	0.022	0.024
A1	0.00	0.02	0.05	0.000	0.001	0.002
A2	0.152REF			0.006REF		
b	0.20	0.25	0.30	0.008	0.010	0.012
D	2.40	2.50	2.60	0.094	0.098	0.102
E	2.40	2.50	2.60	0.094	0.098	0.102
D1	1.30	1.40	1.50	0.050	0.055	0.059
E1	1.30	1.40	1.50	0.050	0.055	0.059
e	0.40	0.50	0.60	0.016	0.020	0.024
K	0.15	-	-	0.006	-	-
L	0.16	0.235	0.31	0.006	0.009	0.012
L1	0.22	0.30	0.37	0.010	0.012	0.014
M	0.28REF			0.011REF		



## X-ON Electronics

Largest Supplier of Electrical and Electronic Components

*Click to view similar products for [Analogue Switch ICs category](#):*

*Click to view products by [RUNIC manufacturer](#):*

Other Similar products are found below :

[FSA3051TMX](#) [NLVAS4599DTT1G](#) [MAX4992EVB+T](#) [MAX4684ETB+T](#) [BCM6522IPBG](#) [BCM65300IFSBG](#) [MAX14764ETA+T](#)  
[TMUX1113RSVR](#) [TMUX1112RSVR](#) [ADG1436TRUZ-EP](#) [BL4684C](#) [PE423422A](#) [PE42359SCAA](#) [PE42540F](#) [RS550YUCM12](#)  
[ADGS1414DBCCZ](#) [ADG658YRUZ-REEL7](#) [RS2117YUTQK10](#) [RS2118YUTQK10](#) [RS2227XUTQK10](#) [SP2526A-1EN-L/TR](#) [FSA4157P6X](#)  
[BA7603F-E2](#) [MAX4702EUE+](#) [MAX4617CUE+](#) [MAX4599EUT+T](#) [MAX4066ESD+](#) [MAX4052ACSE+](#) [MAX396CAI+](#) [MAX391CPE+](#)  
[MAX4730EXT+T](#) [MAX314CPE+](#) [MAX4051AEEE+](#) [BU4066BCFV-E2](#) [MAX313CPE+](#) [BU4S66G2-TR](#) [TS3A4751PWR](#)  
[NCN1154MUTAG](#) [DG444DY-E3](#) [NLAS4157DFT2G](#) [NLAS4599DFT2G](#) [NLAS7242MUTBG](#) [NLASB3157DFT2G](#) [NLAST4599DFT2G](#)  
[NLAST4599DTT1G](#) [DG403DY-T1-E3](#) [MAX4714EXTT](#) [MAX392CPE](#) [BGSX22G2A10E6327XTSA1](#) [ADG1611BRUZ-REEL7](#)