

RS74HC74 Dual Positive-Edge-Triggered D-Type Flip-Flop with set and reset

1 FEATURES

- **Operating Voltage Range: 1.65V to 5.5V**
- **Low Power Consumption: 10 μ A (Max)**
- **Operating Temperature Range: -40 $^{\circ}$ C to +125 $^{\circ}$ C**
- **Inputs Accept Voltage to 5.5V**
- **High Output Drive: \pm 24mA at V_{CC} =3.0V**
- **I_{off} Supports Live Insertion, Partial-Power-Down Mode, and Back-Drive Protection**
- **Micro SIZE PACKAGES: SOIC-14(SOP14) and TSSOP-14**

2 APPLICATIONS

- **Network Switch**
- **Telecom Infrastructure**
- **Servers**
- **I/O Expanders**
- **LED Displays**

3 DESCRIPTIONS

The RS74HC74 dual positive-edge-triggered D-type flipflop is designed for 1.65V to 5.5V V_{CC} operation.

The RS74HC74 have individual data (nD), clock (nCP), set (n \bar{S} D) and reset (n \bar{R} D) inputs, and complementary nQ and n \bar{Q} outputs. Data at the nD-input, that meets the set-up and hold time requirements on the LOW-to-HIGH clock transition, is stored in the flip-flop and appears at the nQ output.

The RS74HC74 is fully specified for partial-power-down applications using I_{off}. The I_{off} circuitry disables the outputs, preventing damaging current backflow through the device when it is powered down.

This device available in Green SOIC-14(SOP14) and TSSOP-14 packages. It operates over an ambient temperature range of -40 $^{\circ}$ C to +125 $^{\circ}$ C.

Device Information (1)

PART NUMBER	PACKAGE	BODY SIZE (NOM)
RS74HC74	SOIC-14 (SOP14)	8.60mm \times 3.85mm
	TSSOP-14	5.00mm \times 4.40mm

(1) For all available packages, see the orderable addendum at the end of the data sheet.

Simplified Schematic

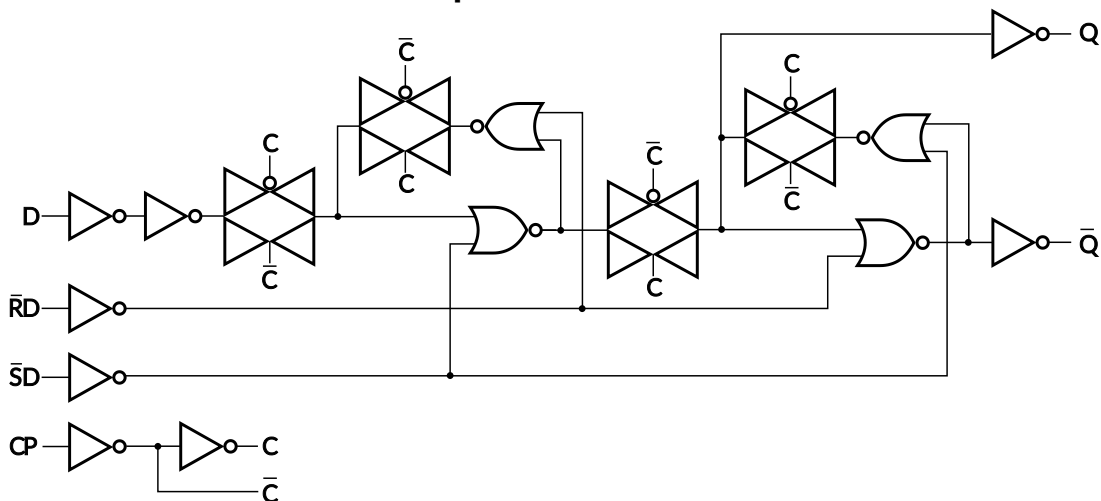

Table of Contents

1 FEATURES	1
2 APPLICATIONS	1
3 DESCRIPTIONS	1
4 Revision History	3
5 PACKAGE/ORDERING INFORMATION ⁽¹⁾	4
6 PIN CONFIGURATIONS	5
6.1 PIN DESCRIPTION.....	5
6.2 FUNCTION TABLE	5
7 SPECIFICATIONS	6
7.1 Absolute Maximum Ratings ⁽¹⁾	6
7.2 ESD Ratings	6
8 ELECTRICAL CHARACTERISTICS	7
8.1 Recommended Operating Conditions.....	7
8.2 DC Characteristics	8
8.3 Switching Characteristics.....	9
8.4 Operating Characteristics	9
8.5 TYPICAL CHARACTERISTICS	9
9 Test Circuits and Waveforms	10
10 PACKAGE OUTLINE DIMENSIONS	12
11 TAPE AND REEL INFORMATION	14

4 Revision History

Note: Page numbers for previous revisions may differ from page numbers in the current version.

Version	Change Date	Change Item
A.1	2023/10/17	Initial version completed

5 PACKAGE/ORDERING INFORMATION ⁽¹⁾

PRODUCT	ORDERING NUMBER	TEMPERATURE RANGE	PACKAGE LEAD	PACKAGE MARKING ⁽²⁾	MSL ⁽³⁾	PACKAGE OPTION
RS74HC74	RS74HC74XP	-40°C ~+125°C	SOIC-14 (SOP14)	RS74HC74	MSL3	Tape and Reel,4000
	RS74HC74XQ	-40°C ~+125°C	TSSOP-14	RS74HC74	MSL3	Tape and Reel,4000

NOTE:

- (1) This information is the most current data available for the designated devices. This data is subject to change without notice and revision of this document. For browser-based versions of this data sheet, refer to the right-hand navigation.
- (2) There may be additional marking, which relates to the lot trace code information (data code and vendor code), the logo or the environmental category on the device.
- (3) MSL, The Moisture Sensitivity Level rating according to the JEDEC industry standard classifications.

6 PIN CONFIGURATIONS

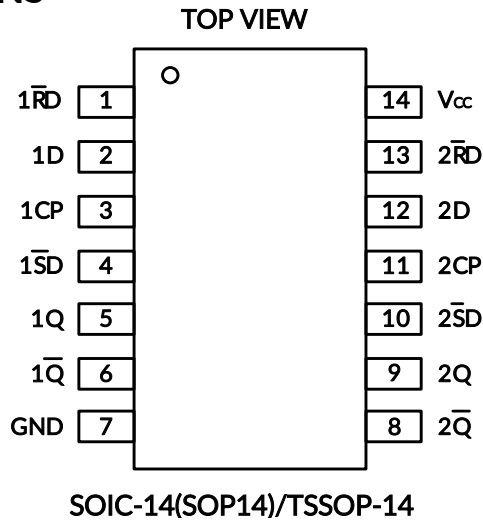

6.1 PIN DESCRIPTION

PIN	NAME	I/O TYPE ⁽¹⁾	FUNCTION
SOIC-14(SOP14)/TSSOP-14			
1	1RD	I	Asynchronous reset-direct input (active LOW)
2	1D	I	Data Input
3	1CP	I	Clock Input
4	1SD	I	Asynchronous set-direct input (active LOW)
5	1Q	O	Output
6	1Q	O	complement output
7	GND	-	Ground
8	2Q	O	complement output
9	2Q	O	Output
10	2SD	I	Asynchronous set-direct input (active LOW)
11	2CP	I	Clock Input
12	2D	I	Data Input
13	2RD	I	Asynchronous reset-direct input (active LOW)
14	V _{CC}	P	Supply

(1) I=input, O=output, P=power.

6.2 FUNCTION TABLE

INPUTS				OUTPUT	
nSD	nRD	nCP	nD	nQ	nQ
L	H	X	X	H	L
H	L	X	X	L	H
L	L	X	X	H ⁽¹⁾	H ⁽¹⁾
H	H	↑	H	H	L
H	H	↑	L	L	H
H	H	L	X	Q ₀	Q ₀

(1) H=High Voltage Level
L=Low Voltage Level
X=Don't Care

7 SPECIFICATIONS

7.1 Absolute Maximum Ratings ⁽¹⁾

over operating free-air temperature range (unless otherwise noted) ^{(1) (2)}

		MIN	MAX	UNIT
V _{CC}	Supply voltage range	-0.5	6.5	V
V _I	Input voltage range ⁽²⁾	-0.5	6.5	V
V _O	Voltage range applied to any output in the high-impedance or power-off state ⁽²⁾	-0.5	6.5	V
V _O	Voltage range applied to any output in the high or low state ^{(2) (3)}	-0.5	V _{CC} +0.5	V
I _{IK}	Input clamp current	V _I <0	-50	mA
I _{OK}	Output clamp current	V _O <0	-50	mA
I _O	Continuous output current		±50	mA
	Continuous current through V _{CC} or GND		±100	mA
θ _{JA}	Package thermal impedance ⁽⁴⁾	SOIC-14(SOP14)	105	°C/W
		TSSOP-14	90	
T _J	Junction temperature ⁽⁵⁾	-65	150	°C
T _{stg}	Storage temperature	-65	150	°C

- (1) Stresses beyond those listed under Absolute Maximum Ratings may cause permanent damage to the device. These are stress ratings only, and functional operation of the device at these or any other conditions beyond those indicated under Recommended Operating Conditions is not implied. Exposure to absolute-maximum-rated conditions for extended periods may affect device reliability.
- (2) The input and output negative-voltage ratings may be exceeded if the input and output current ratings are observed.
- (3) The value of V_{CC} is provided in the Recommended Operating Conditions table.
- (4) The package thermal impedance is calculated in accordance with JESD-51.
- (5) The maximum power dissipation is a function of T_{J(MAX)}, R_{θJA}, and T_A. The maximum allowable power dissipation at any ambient temperature is P_D = (T_{J(MAX)} - T_A) / R_{θJA}. All numbers apply for packages soldered directly onto a PCB.

7.2 ESD Ratings

The following ESD information is provided for handling of ESD-sensitive devices in an ESD protected area only.

		VALUE	UNIT
V _(ESD)	Electrostatic discharge	Human-body model (HBM), MIL-STD-883K METHOD 3015.9	±2000
		Charged-device model (CDM), ANSI/ESDA/JEDEC JS-002-2018	±1000
		Machine Model (MM), JESD22-A115C (2010)	±200



ESD SENSITIVITY CAUTION

ESD damage can range from subtle performance degradation to complete device failure. Precision integrated circuits may be more susceptible to damage because very small parametric changes could cause the device not to meet its published specifications.

8 ELECTRICAL CHARACTERISTICS

over recommended operating free-air temperature range (TYP values are at $T_A = +25^\circ\text{C}$, Full= -40°C to 125°C , unless otherwise noted.) ⁽¹⁾

8.1 Recommended Operating Conditions

PARAMETER	SYMBOL	TEST CONDITIONS	MIN	MAX	UNIT
Supply voltage	V_{CC}	Operating	1.65	5.5	V
High-level input voltage	V_{IH}	$V_{CC}=1.65\text{V to }1.95\text{V}$	$0.75 \times V_{CC}$		V
		$V_{CC}=2.3\text{V to }2.7\text{V}$	1.7		
		$V_{CC}=3\text{V to }3.6\text{V}$	2		
		$V_{CC}=4.5\text{V to }5.5\text{V}$	$0.7 \times V_{CC}$		
Low-level input voltage	V_{IL}	$V_{CC}=1.65\text{V to }1.95\text{V}$		$0.25 \times V_{CC}$	V
		$V_{CC}=2.3\text{V to }2.7\text{V}$		0.7	
		$V_{CC}=3\text{V to }3.6\text{V}$		0.8	
		$V_{CC}=4.5\text{V to }5.5\text{V}$		$0.3 \times V_{CC}$	
Input voltage	V_I		0	5.5	V
Output voltage	V_O		0	V_{CC}	V
High-level output current	I_{OH}	$V_{CC}=1.65\text{V}$		-4	mA
		$V_{CC}=2.3\text{V}$		-8	
		$V_{CC}=3\text{V}$		-16	
		$V_{CC}=4.5\text{V}$		-32	
Low-level output current	I_{OL}	$V_{CC}=1.65\text{V}$		4	mA
		$V_{CC}=2.3\text{V}$		8	
		$V_{CC}=3\text{V}$		16	
		$V_{CC}=4.5\text{V}$		32	
Input transition rise or fall	$\Delta t / \Delta v$	$V_{CC}=1.8\text{V} \pm 0.15\text{V}, 2.5\text{V} \pm 0.2\text{V}$		20	ns/V
		$V_{CC}=3.3\text{V} \pm 0.3\text{V}$		10	
		$V_{CC}=5\text{V} \pm 0.5\text{V}$		10	
Operating temperature	T_A		-40	125	$^\circ\text{C}$

(1) All unused inputs of the device must be held at V_{CC} or GND to ensure proper device operation.

8.2 DC Characteristics

PARAMETER		TEST CONDITIONS	V _{CC}	TEMP	MIN ⁽²⁾	TYP ⁽³⁾	MAX ⁽²⁾	UNIT
V _{OH}		I _{OH} = -100μA	1.65V to 5.5V	Full	V _{CC} -0.1			V
		I _{OH} = -4mA	1.65V		1.2			
		I _{OH} = -8mA	2.3V		1.9			
		I _{OH} = -16mA	3V		2.4			
		I _{OH} = -24mA			2.3			
		I _{OH} = -32mA	4.5V		3.8			
V _{OL}		I _{OL} = 100μA	1.65V to 5.5V	Full			0.1	V
		I _{OL} = 4mA	1.65V				0.45	
		I _{OL} = 8mA	2.3V				0.3	
		I _{OL} = 16mA	3V				0.4	
		I _{OL} = 24mA					0.55	
		I _{OL} = 32mA	4.5V				0.55	
I _i	All inputs	V _I =5.5V or GND	0V to 5.5V	+25°C		±0.1	±1	μA
				Full			±5	
	I _{off}	V _I or V _O =5.5V	0	+25°C		±0.1	±1	μA
				Full			±10	
	I _{CC}	V _I =5.5V or GND, I _O =0	1.65V to 5.5V	+25°C		0.1	1	μA
				Full			10	
	ΔI _{CC}	One input at V _{CC} -0.6V, Other inputs at V _{CC} or GND	3V to 5.5V	Full			500	μA
	C _i (Input Capacitance)	V _I = V _{CC} or GND	3.3V	+25°C		3		pF

(1) All unused inputs of the device must be held at V_{CC} or GND to ensure proper device operation.

(2) Limits are 100% production tested at 25°C. Limits over the operating temperature range are ensured through correlations using statistical quality control (SQC) method.

(3) Typical values represent the most likely parametric norm as determined at the time of characterization. Actual typical values may vary over time and will also depend on the application and configuration.

8.3 Switching Characteristics

over recommended operating free-air temperature range (unless otherwise noted) ⁽¹⁾

PARAMETER	FROM (INPUT)	TO (OUTPUT)	TEMP	V _{CC} =1.8V		V _{CC} =2.5V		V _{CC} =3.3V		V _{CC} =5V		UNIT
				MIN	MAX	MIN	MAX	MIN	MAX	MIN	MAX	
f _{max}			-40°C to 85°C		30		65		100		155	MHz
			-40°C to 125°C						100		155	
t _{pd}	nCP	nQ	-40°C to 85°C	4.8	23.5	2.2	15.5	2.2	11.5	1.4	9.2	ns
			-40°C to 125°C					2.2	12.5	1.4	9.5	
		n \bar{Q}	-40°C to 85°C	6	25.5	3	17	2.6	12.5	1.6	9.6	
			-40°C to 125°C					2.6	13.5	1.6	10	
	n \bar{SD} or n \bar{RD}	nQ or n \bar{Q}	-40°C to 85°C	4.4	27	2.3	16	1.7	12	1.6	9.4	
			-40°C to 125°C					1.7	13	1.6	9.8	

(1) This parameter is ensured by design and/or characterization and is not tested in production.

8.4 Operating Characteristics

T_A = +25°C

PARAMETER	TEST CONDITIONS	V _{CC} = 1.8V	V _{CC} = 2.5V	V _{CC} = 3.3V	V _{CC} = 5V	UNIT
		TYP	TYP	TYP	TYP	
C _{pd} Power dissipation capacitance	f = 10 MHz	22	25	32	40	pF

8.5 TYPICAL CHARACTERISTICS

NOTE: The graphs and tables provided following this note are a statistical summary based on a limited number of samples and are provided for informational purposes only.

At T_A = +25°C, V_{CC}=3.3V, unless otherwise noted.

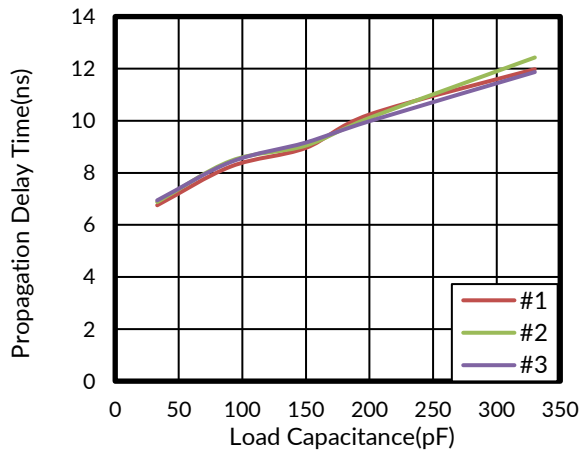

Figure 1. Propagation Delay (Low to High Transition) vs Load Capacitance

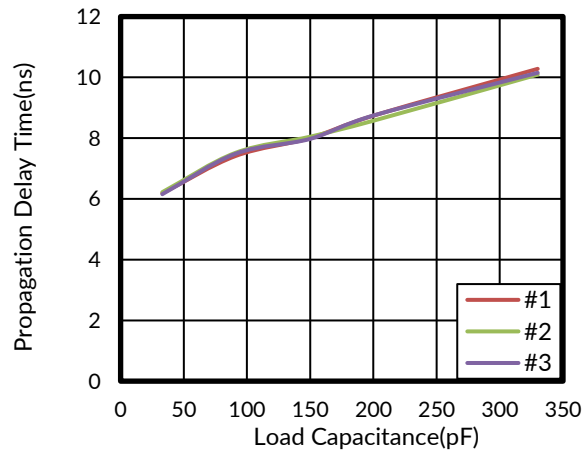
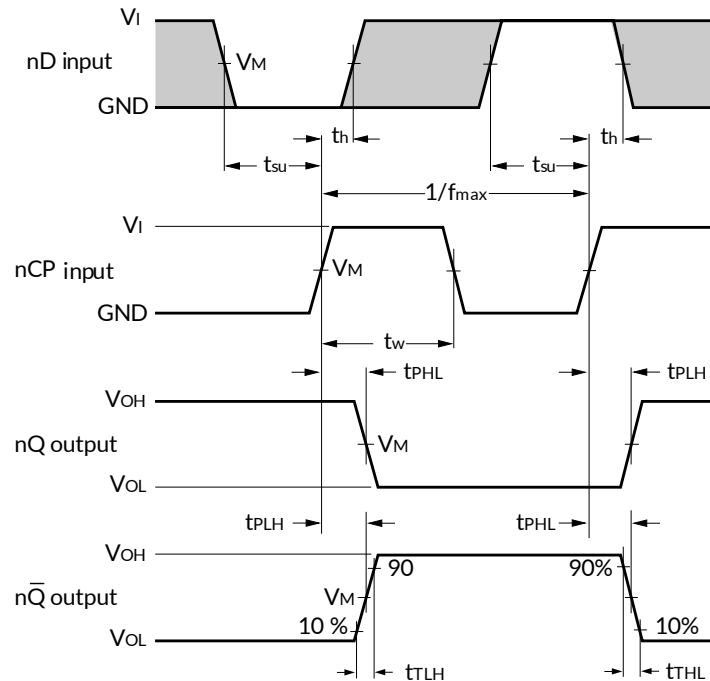

Figure 2. Propagation Delay (High to Low Transition) vs Load Capacitance

9 Test Circuits and Waveforms



Measurement points are given in Table 1.

V_{OL} and V_{OH} are typical output levels that occur with the output load.

Figure 3. Propagation delay input (CP) to output (Qn), output transition time, clock input (CP) pulse width and the maximum frequency (CP)

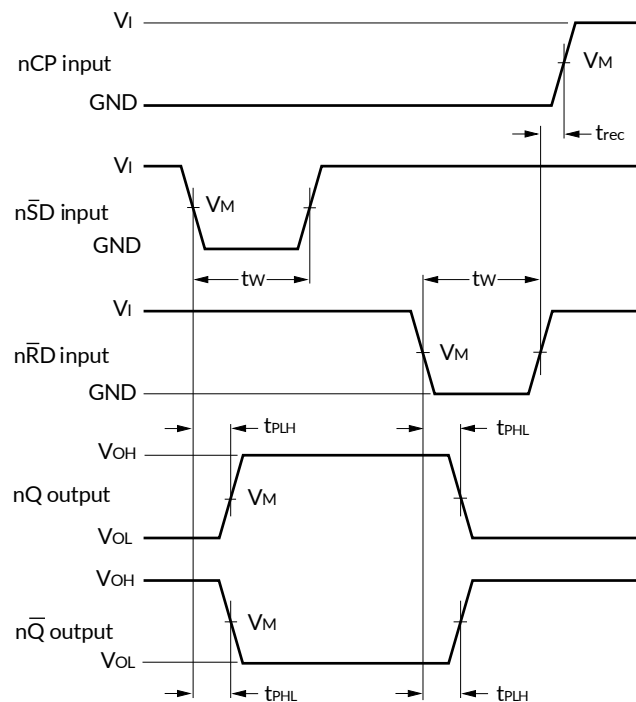

Measurement points are given in Table 1.

V_{OL} and V_{OH} are typical output levels that occur with the output load.

Figure 4. The set (nSD) and reset (nRD) input to output (nQ, nQ-bar) propagation delays, set and reset pulse widths and the nSD, nRD to nCP recovery time

Table 1. Measurement points

Input	Output
V_M	V_M
$0.5V_{CC}$	$0.5V_{CC}$

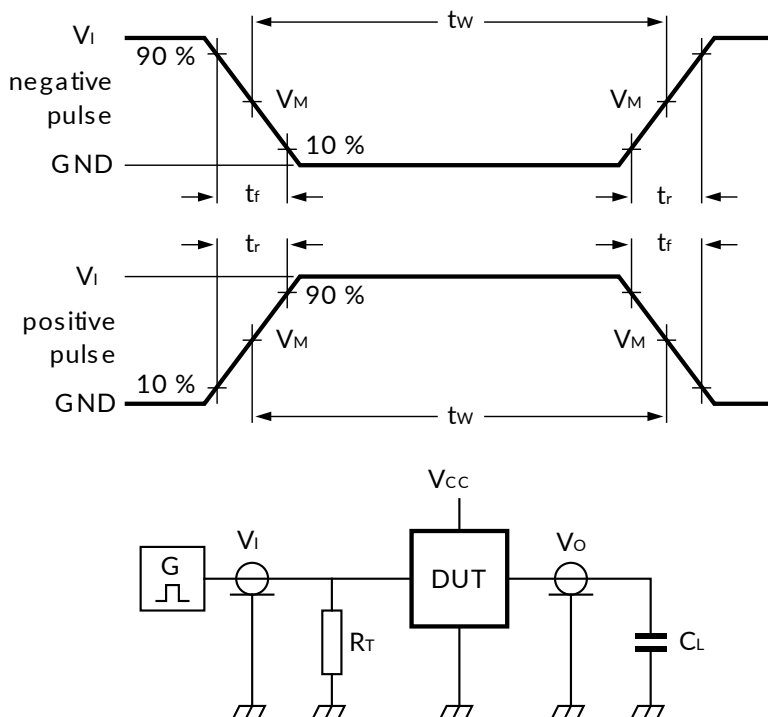

Test data is given in Table 2.

Definitions test circuit:

R_T = Termination resistance should be equal to output impedance Z_O of the pulse generator.

C_L = Load capacitance including jig and probe capacitance.

R_L = Load resistance.

S1 = Test selection switch

Figure 5. Test circuit for measuring switching times
Table 2. Test data

Input		Load		Test
V_I	t_r, t_f	C_L	R_L	
V_{CC}	6ns	15pF, 50pF	1k Ω	t_{PHL}, t_{PLH}

10 PACKAGE OUTLINE DIMENSIONS

SOIC-14(SOP14)⁽³⁾

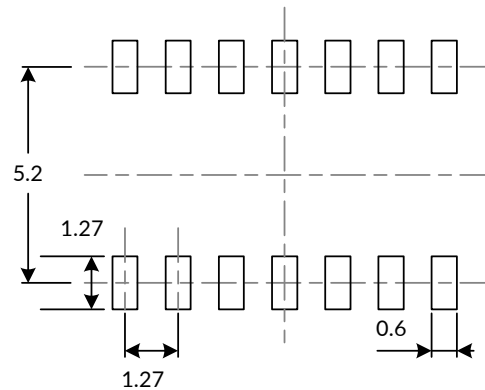
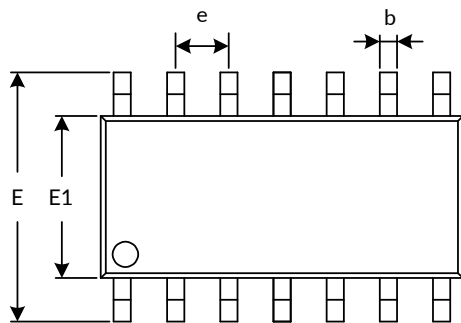

RECOMMENDED LAND PATTERN (Unit: mm)

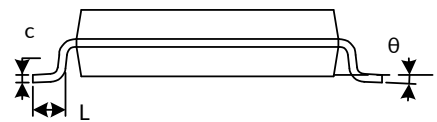
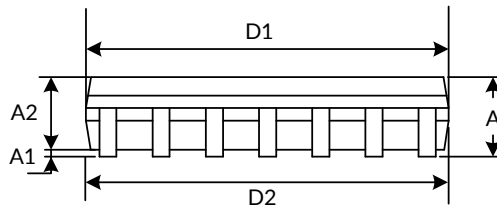

Symbol	Dimensions In Millimeters		Dimensions In Inches	
	Min	Max	Min	Max
A ⁽¹⁾	1.500	1.700	0.059	0.067
A1	0.100	0.200	0.004	0.008
A2	1.400	1.500	0.055	0.059
b	0.375	0.425	0.015	0.017
c	0.200	0.240	0.008	0.009
D1 ⁽¹⁾	8.550	8.650	0.336	0.341
D2	8.600	8.700	0.338	0.343
e	1.270(BSC) ⁽²⁾		0.050(BSC) ⁽²⁾	
E	5.900	6.100	0.232	0.240
E1 ⁽¹⁾	3.800	3.900	0.150	0.154
L	0.500	0.700	0.020	0.028
θ	0°	8°	0°	8°

NOTE:

1. Plastic or metal protrusions of 0.15mm maximum per side are not included.
2. BSC (Basic Spacing between Centers), "Basic" spacing is nominal.
3. This drawing is subject to change without notice.

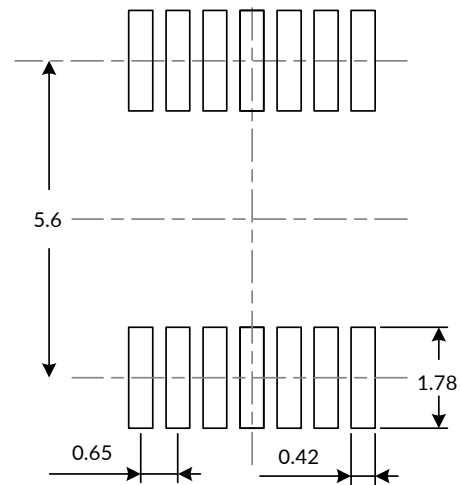
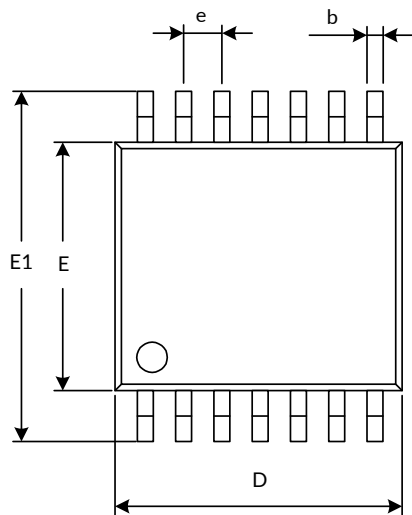
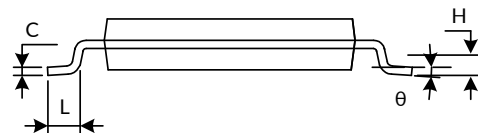
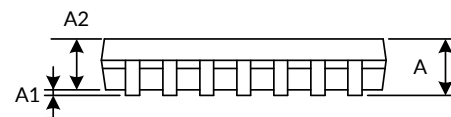
TSSOP-14⁽³⁾

RECOMMENDED LAND PATTERN (Unit: mm)

Symbol	Dimensions In Millimeters		Dimensions In Inches	
	Min	Max	Min	Max
A ⁽¹⁾		1.200		0.047
A1	0.050	0.150	0.002	0.006
A2	0.900	1.050	0.035	0.041
b	0.200	0.300	0.008	0.012
c	0.130	0.170	0.005	0.007
D ⁽¹⁾	4.860	5.100	0.191	0.201
E ⁽¹⁾	4.300	4.500	0.169	0.177
E1	6.200	6.600	0.244	0.260
e	0.650(BSC) ⁽²⁾		0.026(BSC) ⁽²⁾	
L	0.450	0.750	0.018	0.030
H	0.250(TYP)		0.010(TYP)	
θ	0°	8°	0°	8°

NOTE:

1. Plastic or metal protrusions of 0.15mm maximum per side are not included.
2. BSC (Basic Spacing between Centers), "Basic" spacing is nominal.
3. This drawing is subject to change without notice.

11 TAPE AND REEL INFORMATION

REEL DIMENSIONS

TAPE DIMENSION

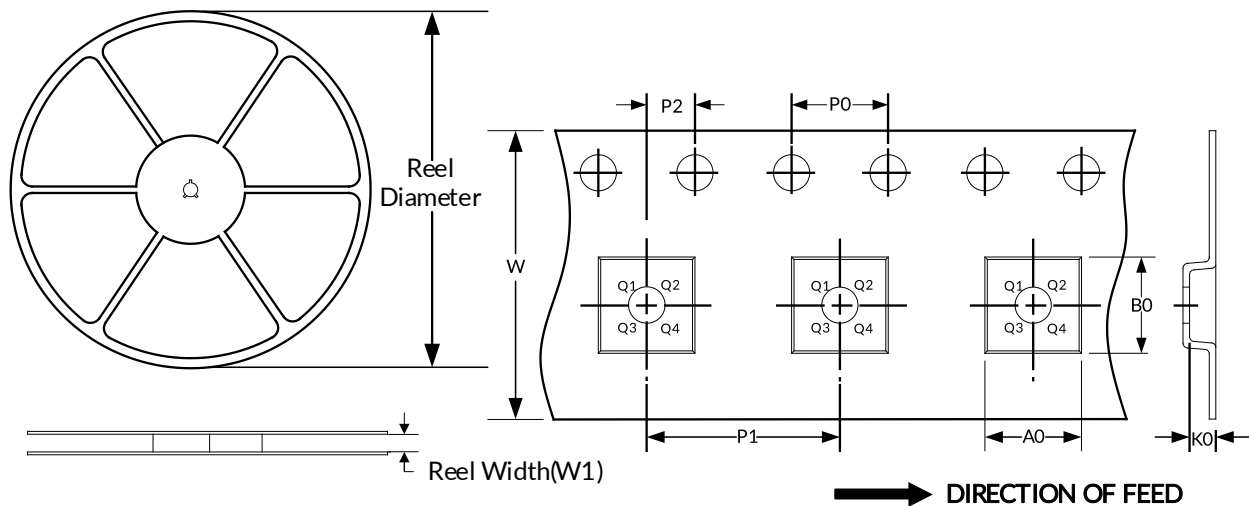

NOTE: The picture is only for reference. Please make the object as the standard.

KEY PARAMETER LIST OF TAPE AND REEL

Package Type	Reel Diameter	Reel Width(mm)	A0 (mm)	B0 (mm)	K0 (mm)	P0 (mm)	P1 (mm)	P2 (mm)	W (mm)	Pin1 Quadrant
SOIC-14(SOP14)	13"	16.4	6.60	9.30	2.10	4.0	8.0	2.0	16.0	Q1
TSSOP-14	13"	12.4	6.95	5.60	1.20	4.0	8.0	2.0	12.0	Q1

NOTE:

1. All dimensions are nominal.
2. Plastic or metal protrusions of 0.15mm maximum per side are not included.

IMPORTANT NOTICE AND DISCLAIMER

Jiangsu Runic Technology Co., Ltd. will accurately and reliably provide technical and reliability data (including data sheets), design resources (including reference designs), application or other design advice, WEB tools, safety information and other resources, without warranty of any defect, and will not make any express or implied warranty, including but not limited to the warranty of merchantability Implied warranty that it is suitable for a specific purpose or does not infringe the intellectual property rights of any third party.

These resources are intended for skilled developers designing with Runic products You will be solely responsible for: (1) Selecting the appropriate products for your application; (2) Designing, validating and testing your application; (3) Ensuring your application meets applicable standards and any other safety, security or other requirements; (4) Runic and the Runic logo are registered trademarks of Runic Incorporated. All trademarks are the property of their respective owners; (5) For change details, review the revision history included in any revised document. The resources are subject to change without notice. Our company will not be liable for the use of this product and the infringement of patents or third-party intellectual property rights due to its use.

X-ON Electronics

Largest Supplier of Electrical and Electronic Components

Click to view similar products for [Flip-Flops](#) category:

Click to view products by [RUNIC](#) manufacturer:

Other Similar products are found below :

[NLV74HC74ADTR2G](#) [74F574SC](#) [TC7W74FUTE12LF](#) [NLV14013BDR2G](#) [NLV74HC74ADR2G](#) [MC10EP131MNG](#) [MC74AC74DTR2](#)
[74VHC574FT\(BJ\)](#) [HT4093ARZ](#) [SN74HC374ANSR](#) [CD4528BE](#) [CD4027BE](#) [RS74HC74XQ](#) [RS574XTSS20](#) [74HCT273PW-Q100J](#)
[SN74ABT273PWRE4](#) [CLVC2G74QDCURG4Q1](#) [CD4067TA24.TB](#) [CD4013SA.TR](#) [AIP74HCT14TA14.TB](#) [HSN74LVC1G14DBVR](#)
[CD4013BPWRG](#) [AiP74LVC74TA14.TB](#) [CD4013BDRG](#) [CD4528SA16.TR](#) [AIP74HC273SA.TB](#) [SN74HCS74QDYRQ1](#) [CD4013TA14.TB](#)
[SN74LS107N](#) [SN74LS374DWR](#) [SN74LVC2G14DC\(LX\)](#) [MC74HC73ADG](#) [MC74HC73ADR2G](#) [74LCX16374MTDX](#) [74LVT74D,118](#)
[74VHCT9273FT\(BJ\)](#) [MM74HC374WM](#) [MM74HC74AMX](#) [74ALVCH162374PAG](#) [74LVC1G175GS,132](#) [74LVX74MTCX](#)
[TC7WZ74FK,LJ\(CT\)](#) [MM74HCT273WM](#) [SN74LVC74AD](#) [SN74HC273DWR](#) [M74HC374RM13TR](#) [M74HC175B1R](#) [M74HC174RM13TR](#)
[74ALVTH32374ZKER](#) [74AUP1G74DC,125](#)