



KITRA 520

Data sheet

19/09/2017



Summary

.1	REVISION HISTORY	2
.2	KITRA 520 IMAGES	3
.3	INTRODUCTION	4
.4	DESCRIPTION	4
.5	BLOCK DIAGRAM	5
.6	HARDWARE & COMPONENTS DETAIL	6
.6.1	Samsung ARTIK 520 module	6
.6.2	CPU	6
.6.3	Battery presents in the starter KIT	7
.6.4	iNEMO inertial module LSM6DS3TR	7
.6.5	Digital output magnetic sensor	8
.6.6	Barometer	9
.6.7	Proximity sensor for short range measurement	10
.6.8	Proximity sensor for long range measurement	11
.6.9	Four MEMS microphones	12
.6.10	RGB LEDs Driver	13
.6.11	LRA haptic motor Driver	14
.6.12	Capacitive touch	16
.6.13	Audio codec	16
.7	EXTERNAL MULTIMEDIA ACCESSORIES	18
.7.1	DISPLAY	18
.7.2	CAMERA	19
.8	EXPANSIONS CONNECTOR	21
.9	EXPANSION CONNECTORS PINS TABLE	22
.9.1	Other connectors	24
.10	GETTING STARTED AND DEVELOPMENT WITH KITRA 520	25
.10.1	KITRA-COM	25
.10.2	Board reference	25
.10.3	First steps	26
.10.4	Communicate with artik	27
.10.5	Writing your own node-red application	29
.10.6	LED example	30
.10.7	Preparing artik.cloud	32
.10.8	Sensor example	32
.10.9	Other examples	33
.10.10	Firmware upgrade	34
.10.11	Turn off	34
.10.12	Known issues	34
.11	SPECIFICATIONS	34
.12	MECHANICAL SPECIFICATIONS	35
.13	HOUSING PRESCRIPTION	35
.14	PACKAGING of THE STARTER KIT	35

.15	DECLARATION OF CONFORMITY	36
.16	IMPORTANT NOTES	37
.17	INDOOR USE ONLY FOR 5GHZ BAND	37
.18	OPERATING ENVIRONMENT	37
.19	DICLAIMERS	37

.1 REVISION HISTORY

Date	Author	Description
31/01/2017	C. Raineri	Draft version
28/04/2017	C. Raineri	Added battery prescription, added internal use prescription on Wi-Fi 5GHz band, expansion connectors functional notes and specifications, Declaration of Conformity, modified KITRA 520 images.
20/07/2017	M. Fumagalli	Added display/camera connection guide
20/07/2017	C. Raineri	Added more information about external battery usage Changed pictures

.2 KITRA 520 IMAGES

TOP VIEW WITHOUT SAMSUNG ARTIK 520

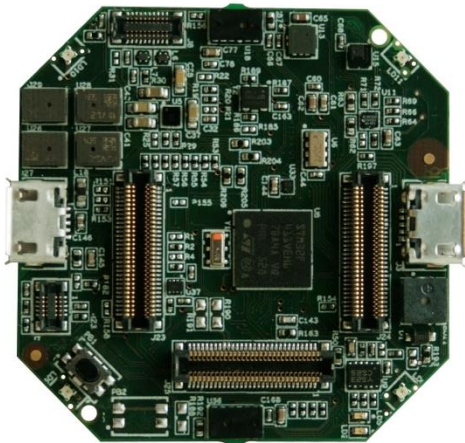

TOP VIEW WITH SAMSUNG ARTIK 520



BOTTOM VIEW



.3 INTRODUCTION

This data sheet provides the description of the KITRA 520 board, the first member of the KITRA family boards.

KITRA boards represents a set of carrier boards for Samsung ARTIK modules, KITRA 520 is a carrier board for ARTIK 520 SoC module.

As RushUp product, KITRA 520 is an accelerator product and can be used from makers, developers, high mix low volume products and from all who want to benefit from an off the shelf industrialized board.

In particular KITRA 520 is the product accelerator for IoT.

For details about RushUp and ARTIK, please visit:

www.rushup.tech

www.artik.io

.4 DESCRIPTION

The KITRA 520 is a carrier board for ARTIK520 SoC module.

The KITRA board provides power supply and additional peripherals to the ARTIK module, like sensors, multi-media, input, output and ADC. An STM32F411RE microcontroller on board handles most of that and ARTIK communicates with it through a serial interface.

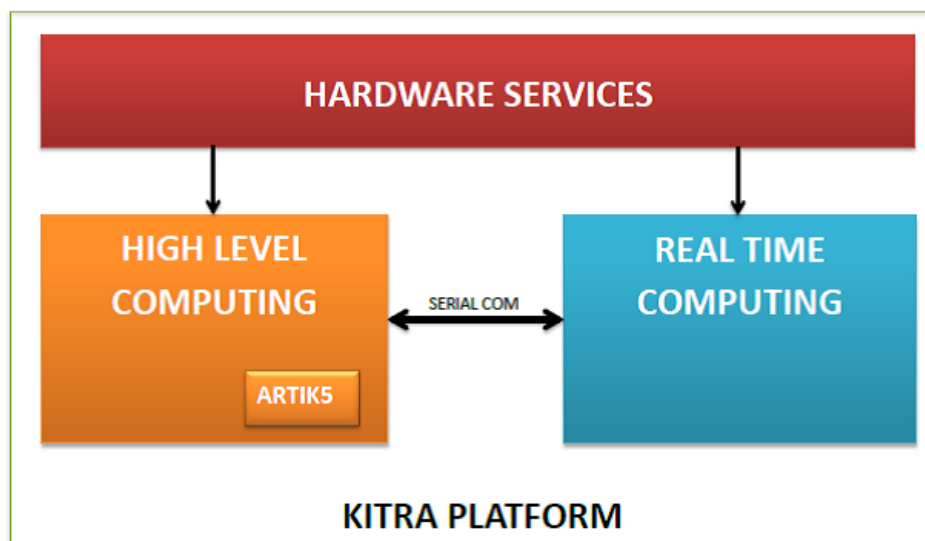

.5 BLOCK DIAGRAM

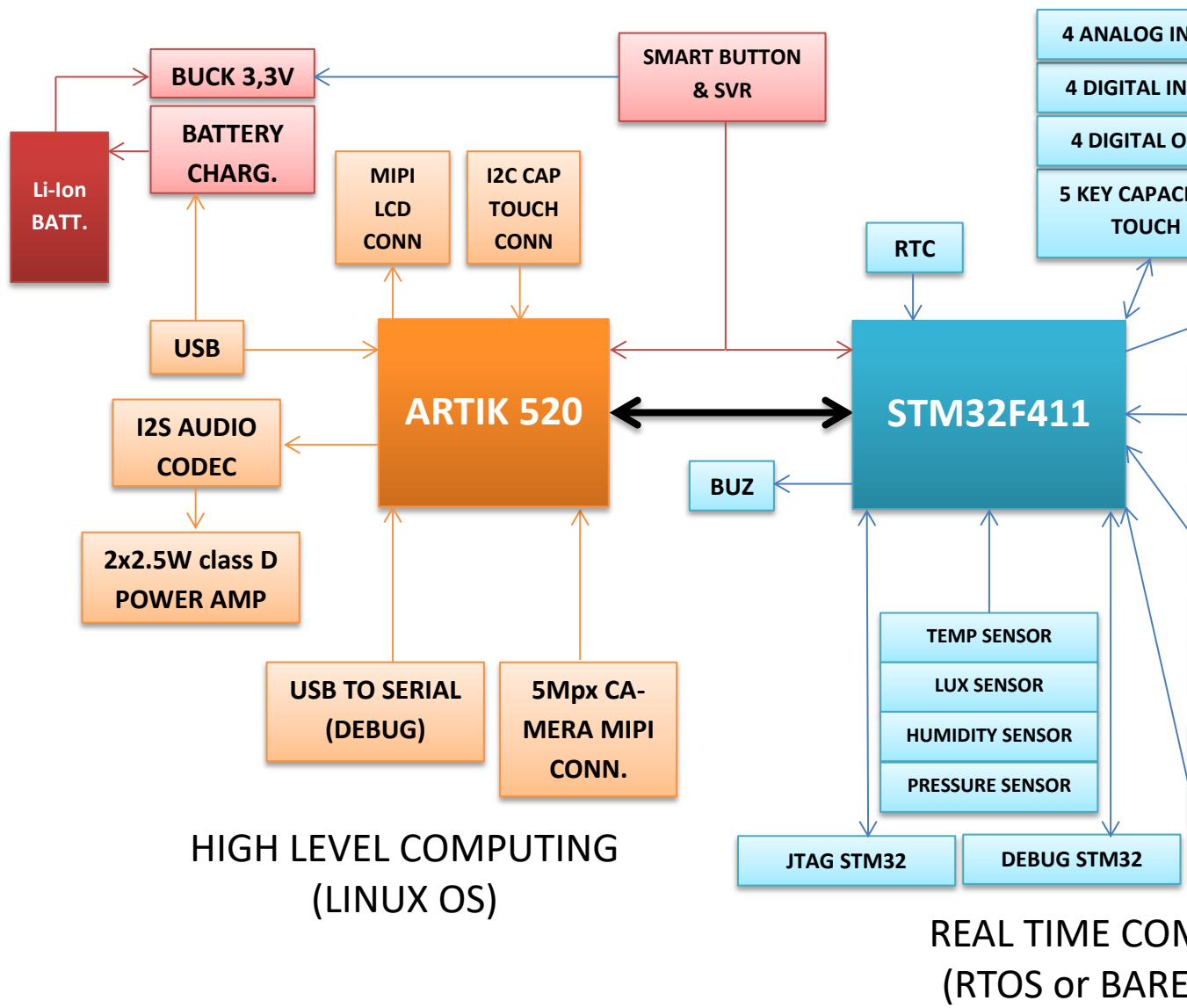

.6 HARDWARE & COMPONENTS DETAIL

.6.1 Samsung ARTIK 520 module

Samsung ARTIK 520 is the IoT module of the KITRA 520 board and it embeds four specific functions:

- Processing;
- Memory;
- Wireless;
- Data security.

Samsung's ARTIK™ 520 Module is a highly-integrated System-in module that utilizes a dual core ARM® Cortex® -A7 processor packaged DRAM and Flash memories, a Secure Element and a wide range of wireless communication options such as 802.11a/b/g/n/ac, Bluetooth® 4.1, Bluetooth Low Energy (BLE), and 802.15.4/ZigBee® communications all into a 30x25mm footprint. The many standard digital control interfaces support external sensors and higher performance peripherals to expand the module capabilities. With the combination of Wi-Fi, Bluetooth and ZigBee the ARTIK 520 Module is the perfect choice for home automation and home hub devices, while also supporting a rich UI/UX capability with the camera and display options. The hardware based Secure Element works with the ARM TrustZone® and Trustonic's Trusted Execution Environment (TEE) to provide "bank level" security end-to-end.

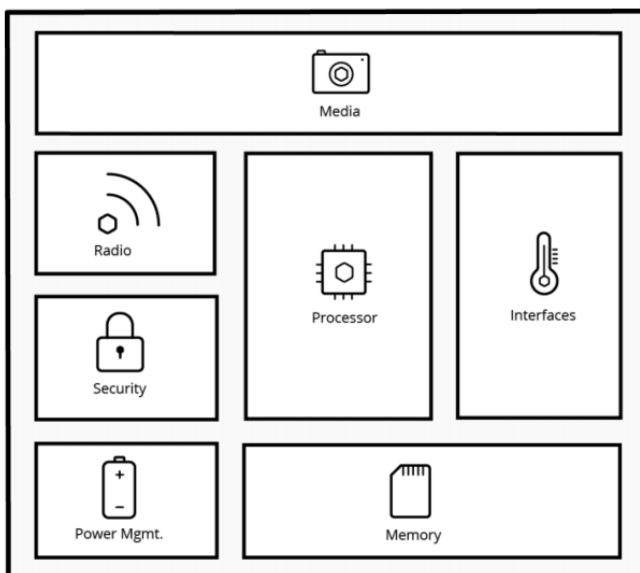

ARTIK 520 Module Block Diagram

Processor	
CPU	Dual core ARM® Cortex®-A7@1.0GHz
GPU	Mali™-400MP2 core
Media	
Camera I/F	1x 2-Lane MIPI CSI up to 3MP@30fps (Supports YUV and JPEG format)
Display	2-Lane MIPI DSI up to qHD 960x540@24bpp
Audio	1-channel PCM and 1-channel 24-bit P5 audio interface
Memory	
DRAM	512MB LPDDR3
FLASH	4GB eMMC
Security	
Secure Element	Secure point to point authentication and data transfer
Trusted Execution Environment	Trustonic TEE (NDA required)
Radio	
WLAN	IEEE802.11a/b/g/n/ac
Bluetooth	BT, BLE
IEEE802.15.4	ZigBee
Power Management	
PMIC	Provides all power of the ARTIK 520 module using on board bucks and LDOs
Interfaces	
Analog and Digital I/O	GPIO, I ² C, SPI, UART, SDIO, USB 2.0, JTAG, Analog Input

Please refer to www.artik.io website for more details on Samsung ARTIK 520 module.

.6.2 CPU

The STM32F411xC/xE devices are based on the high-performance ARM®Cortex® -M4 32-bit RISC core operating at a frequency of up to 100 MHz. The Cortex®-M4 core features a Floating point unit (FPU) single precision which supports all ARM single-precision data-processing instructions and data types. It also implements a full set of DSP instructions and a memory protection unit (MPU) which enhances application security.

The STM32F411xC/xE belongs to the STM32 Dynamic Efficiency™ product line (with products combining power efficiency, performance and integration) while adding a new innovative feature called Batch Acquisition Mode (BAM) allowing to save even more power consumption during data batching.

The STM32F411xC/xE incorporate high-speed embedded memories (up to 512 Kbytes of Flash memory, 128 Kbytes of SRAM), and an extensive range of enhanced I/Os and peripherals connected to two APB buses, two AHB bus and a 32-bit

Refer to for the peripherals available looking at the specific data sheet.

The STM32F401RE operate in the -40 to $+105$ °C temperature range from a 1.7 (PDR OFF) to 3.6 V power supply.

A comprehensive set of power-saving mode allows the design of low-power applications.

.6.3 Battery presents in the starter KIT

ITEM	SPEC
Model	HCP602535ZC
Capacity	Typ: 520 mAh
	Min: 500 mAh
Rated voltage	3.7V
Cycle Life	≥ 500 times
Operating temperature	Charge: 0° to 45°
	Discharge: -20° to 60°

The battery connector mounted on KITRA 520 board is the Molex Pico-EZmate™ type. The connection has durability (mating cycles max) of maximum 10 cycles then use ON/OFF button for power off KITRA instead of unplug the battery.

The USB battery charger embedded in the KITRA 520 generate 400mA of constant current during the charging phase then consider this for active state power consumption analysis and for other battery selection (in case you want to use another battery).

For detailed specifications, check the datasheet of the component.

.6.4 iNEMO inertial module LSM6DS3TR

The LSM6DS3 is a system-in-package featuring a 3D digital accelerometer and a 3D digital gyroscope performing at 1.25 mA (up to 1.6 kHz ODR) in high performance mode and enabling always-on low-power features for an optimal motion experience for the consumer.

The LSM6DS3 supports main OS requirements, offering real, virtual and batch sensors with 8 kbyte for dynamic data batching.

ST's family of MEMS sensor modules leverages the robust and mature manufacturing processes already used for the production of micromachined accelerometers and gyroscopes.

The various sensing elements are manufactured using specialized micromachining processes, while the IC interfaces are developed using CMOS technology that allows the design of a dedicated circuit which is trimmed to better match the characteristics of the sensing element.

The LSM6DS3 has a full-scale acceleration range of $\pm 2/\pm 4/\pm 8/\pm 16$ g and an angular rate range of $\pm 125/\pm 245/\pm 500/\pm 1000/\pm 2000$ dps.

High robustness to mechanical shock makes the LSM6DS3 the preferred choice of system designers for the creation and manufacturing of reliable products.

Features

- Power consumption: 0.9 mA in combo normal mode and 1.25 mA in combo high-performance mode up to 1.6 kHz.
- “Always-on” experience with low power consumption for both accelerometer and gyroscope • Smart FIFO up to 8 kbyte based on features set
- Compliant with Android K and L
- Hard, soft ironing for external magnetic sensor corrections

- $\pm 2/\pm 4/\pm 8/\pm 16$ g full scale • $\pm 125/\pm 245/\pm 500/\pm 1000/\pm 2000$ dps full scale
- Analog supply voltage: 1.71 V to 3.6 V
- Independent IOs supply (1.62 V)
- Compact footprint, 2.5 mm x 3 mm x 0.83 mm
- SPI/I2C serial interface with main processor data synchronization feature
- Embedded temperature sensor
- ECOPACK®, RoHS and “Green” compliant

.6.5 Digital output magnetic sensor

The LIS3MDL is an ultra-low-power high-performance three-axis magnetic sensor.

The LIS3MDL has user-selectable full scales of $\pm 4/ \pm 8/ \pm 12/\pm 16$ gauss.

The self-test capability allows the user to check the functioning of the sensor in the final application.

The device may be configured to generate interrupt signals for magnetic field detection.

The LIS3MDL includes an I2C serial bus interface that supports standard and fast mode (100 kHz and 400 kHz) and SPI serial standard interface.

The LIS3MDL is available in a small thin plastic land grid array package (LGA) and is guaranteed to operate over an extended temperature range of $-40\text{ }^{\circ}\text{C}$ to $+85\text{ }^{\circ}\text{C}$.

Features

- Features
- Wide supply voltage, 1.9 V to 3.6 V
- Independent IO supply (1.8 V)
- $\pm 4/ \pm 8/ \pm 12/ \pm 16$ gauss selectable magnetic full scale
- Continuous and single-conversion modes
- 16-bit data output
- Interrupt generator
- Self-test
- I2C/SPI digital output interface
- Power-down mode/ low-power mode
- ECOPACK®, RoHS and “Green” compliant

.6.5.1 Humidity and temperature

The HTS221 is an ultra-compact sensor for relative humidity and temperature. It includes a sensing element and a mixed signal ASIC to provide the measurement information through digital serial interfaces.

The sensing element consists of a polymer dielectric planar capacitor structure capable of detecting relative humidity variations and is manufactured using a dedicated ST process.

The HTS221 is available in a small top-holed cap land grid array (HLGA) package guaranteed to operate over a temperature range from $-40\text{ }^{\circ}\text{C}$ to $+120\text{ }^{\circ}\text{C}$.

Features

- 0 to 100% relative humidity range
- Supply voltage: 1.7 to 3.6 V
- Low power consumption: 2 μA @ 1 Hz ODR
- Selectable ODR from 1 Hz to 12.5 Hz
- High rH sensitivity: 0.004% rH/LSB
- Humidity accuracy: $\pm 3.5\%$ rH, 20 to +80% rH
- Temperature accuracy: $\pm 0.5\text{ }^{\circ}\text{C}$, 15 to +40 $^{\circ}\text{C}$
- Embedded 16-bit ADC
- 16-bit humidity and temperature output data

- SPI and I²C interfaces
- Factory calibrated
- Tiny 2 x 2 x 0.9 mm package
- ECOPACK® compliant

Block diagram

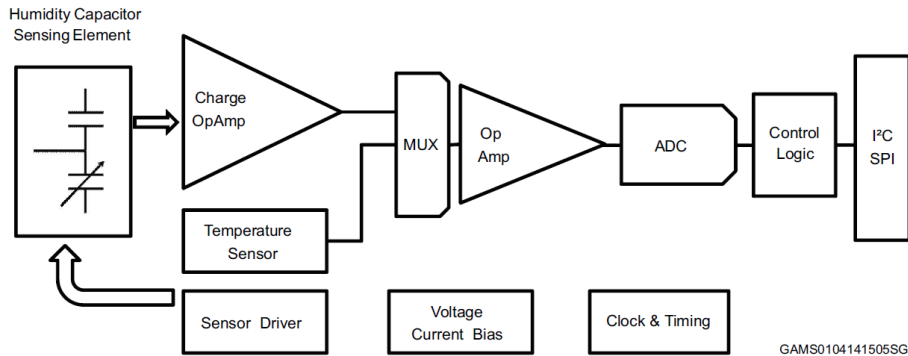

For any specific information and for the firmware commands and procedures, please refer to the data sheet of the components.

.6.6 Barometer

The LPS22HB is an ultra-compact piezo resistive absolute pressure sensor which functions as a digital output barometer.

The device comprises a sensing element and an IC interface which communicates through I2C or SPI from the sensing element to the application.

The sensing element, which detects absolute pressure, consists of a suspended membrane manufactured using a dedicated process developed by ST.

The LPS22HB is available in a full-mold, holed LGA package (HLGA). It is guaranteed to operate over a temperature range extending from -40 °C to +85 °C. The package is holed to allow external pressure to reach the sensing element.

Features

- 260 to 1260 hPa absolute pressure range
- Current consumption down to 3 μ A
- High overpressure capability: 20x full-scale
- Embedded temperature compensation
- 24-bit pressure data output • 16-bit temperature data output
- ODR from 1 Hz to 75 Hz
- SPI and I²C interfaces
- Embedded FIFO
- Interrupt functions: Data Ready, FIFO flags, pressure thresholds
- Supply voltage: 1.7 to 3.6 V
- High shock survivability: 22,000 g
- Small and thin package • ECOPACK® lead-free compliant

Block diagram

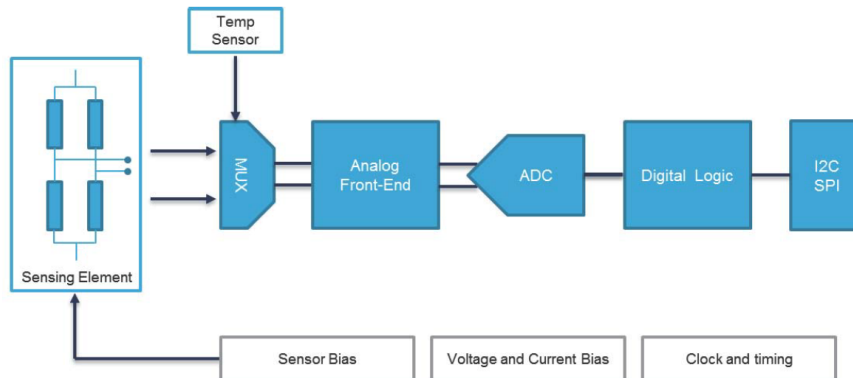

For any specific information and for the firmware commands and procedures, please refer to the data sheet of the components.

.6.7 Proximity sensor for short range measurement

The VL6180X is the latest product based on ST's patented FlightSense™ technology. This is a ground-breaking technology allowing absolute distance to be measured independent of target reflectance. Instead of estimating the distance by measuring the amount of light reflected back from the object (which is significantly influenced by color and surface), the VL6180X precisely measures the time the light takes to travel to the nearest object and reflect back to the sensor (Time-of-Flight).

Combining an IR emitter, a range sensor and an ambient light sensor in a three-in-one ready-to-use reflowable package, the VL6180X is easy to integrate and saves the end-product maker long and costly optical and mechanical design optimizations.

The module is designed for low power operation. Ranging and ALS measurements can be automatically performed at user defined intervals. Multiple threshold and interrupt schemes are supported to minimize host operations.

Host control and result reading is performed using an I2C interface. Optional additional functions, such as measurement ready and threshold interrupts, are provided by two programmable GPIO pins.

Features

- Three-in-one smart optical module
- Proximity sensor
- Ambient Light Sensor
- VCSEL light source
- Fast, accurate distance ranging
 - Measures absolute range from 0 to above 10 cm (ranging beyond 10cm is dependent on conditions) – Independent of object reflectance
 - Ambient light rejection
 - Cross-talk compensation for cover glass
- Gesture recognition
 - Distance and signal level can be used by host system to implement gesture recognition
- Ambient light sensor
 - High dynamic range
 - Accurate/sensitive in ultra-low light
 - Calibrated output value in lux
- Easy integration
 - Single reflowable component
 - No additional optics
 - Single power supply
 - I2C interface for device control and data
 - Provided with a documented C portable API (Application Programming Interface)

Block diagram

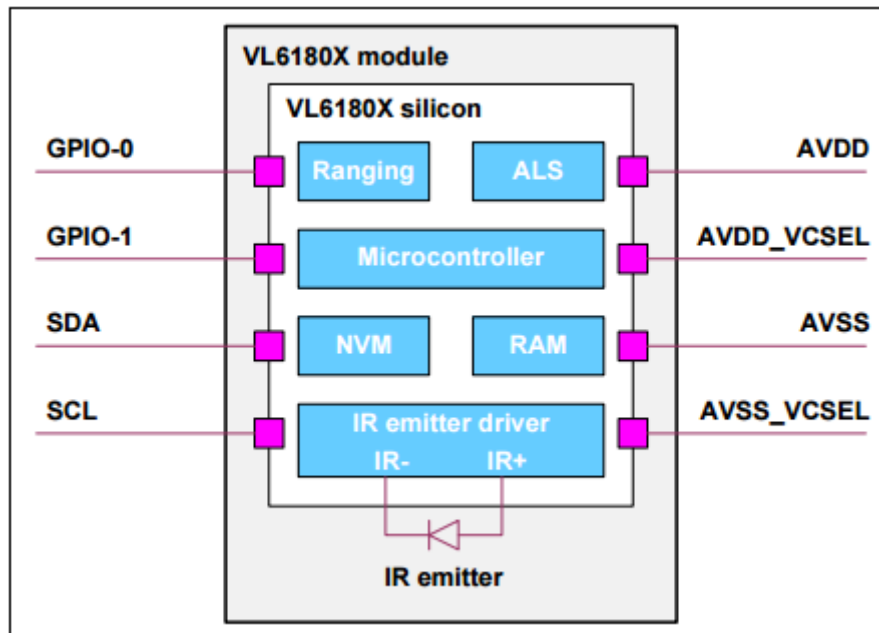

For any specific information and for the firmware commands and procedures, please refer to the data sheet of the components.

.6.8 Proximity sensor for long range measurement

The VL53L0X is a new generation Time-of-Flight (ToF) laser-ranging module housed in the smallest package on the market today, providing accurate distance measurement whatever the target reflectances unlike conventional technologies. It can measure absolute distances up to 2m, setting a new benchmark in ranging performance levels, opening the door to various new applications.

The VL53L0X integrates a leading-edge SPAD array (Single Photon Avalanche Diodes) and embeds ST's second generation FlightSense™ patented technology.

The VL53L0X's 940nm VCSEL emitter (Vertical Cavity Surface-Emitting Laser), is totally invisible to the human eye, coupled with internal physical infrared filters, it enables longer ranging distance, higher immunity to ambient light and better robustness to cover-glass optical cross-talk.

Features

- Fully integrated miniature module
 - 940nm Laser VCSEL
 - VCSEL driver
 - Ranging sensor with advanced embedded micro controller
 - 4.4 x 2.4 x 1.0mm
- Fast, accurate distance ranging
 - Measures absolute range up to 2m
 - Reported range is independent of the target reflectance
 - Operates in high infrared ambient light levels
 - Advanced embedded optical cross-talk compensation to simplify cover glass selection
- Eye safe
 - Class 1 laser device compliant with latest standard IEC 60825-1:2014 - 3rd edition
- Easy integration
 - Single reflowable component
 - No additional optics
 - Single power supply
 - I2C interface for device control and data transfer
 - Xshutdown (Reset) and interrupt GPIO
 - Programmable I2C address

Block Diagram

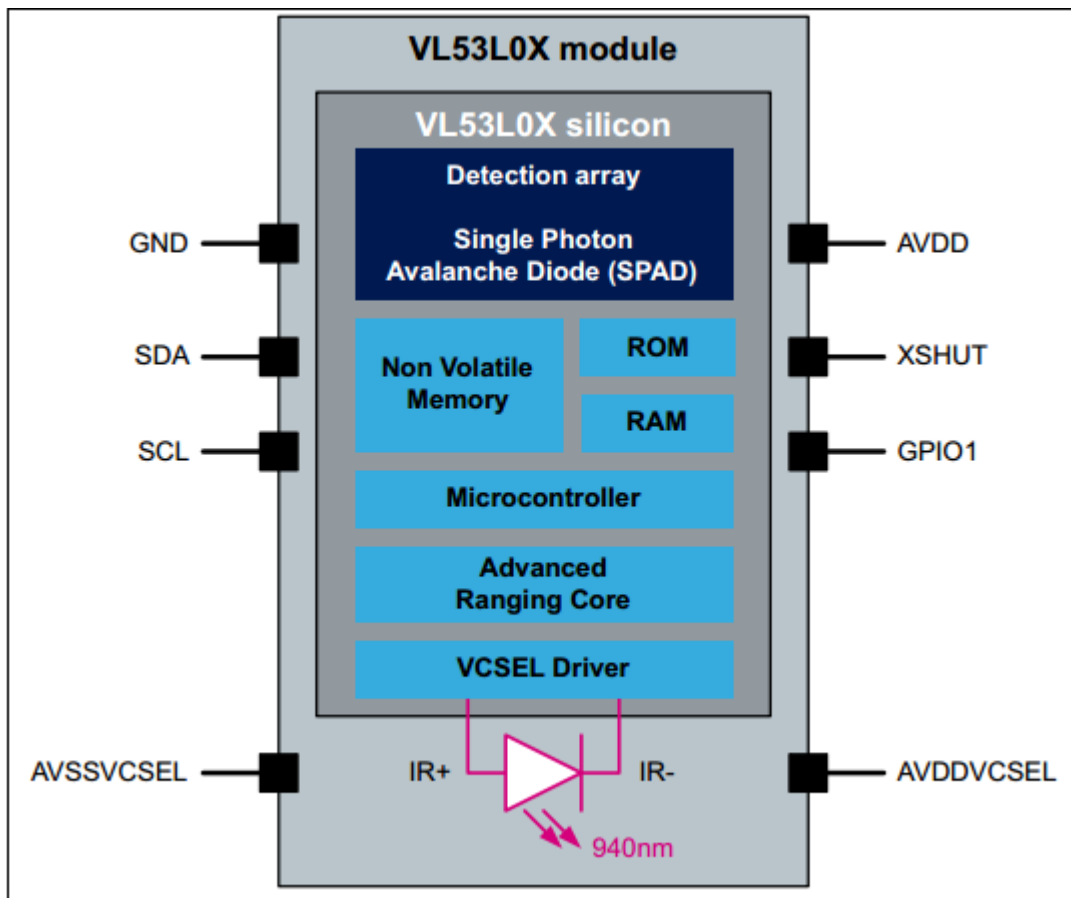

For any specific information and for the firmware commands and procedures, please refer to the data sheet of the components.

.6.9 Four MEMS microphones

The MP34DT04 is an ultra-compact, low-power, omnidirectional, digital MEMS microphone built with a capacitive sensing element and an IC interface.

The sensing element, capable of detecting acoustic waves, is manufactured using a specialized silicon micromachining process dedicated to produce audio sensors.

The IC interface is manufactured using a CMOS process that allows designing a dedicated circuit able to provide a digital signal externally in PDM format.

The MP34DT04 has an acoustic overload point of 120 dB SPL with a 64 dB signal-to-noise ratio and -26 dBFS sensitivity.

The MP34DT04 is available in a top-port, SMD-compliant, EMI-shielded package and is guaranteed to operate over an extended temperature range from -40 °C to +85 °C.

Features

- Single supply voltage
- Low power consumption
- 120 dB SPL acoustic overload point
- 64 dB signal-to-noise ratio
- Omnidirectional sensitivity
- 26 dBFS sensitivity
- PDM output
- HCLGA package

- Top-port design
- SMD-compliant
- EMI-shielded
- ECOPACK®, RoHS, and “Green” compliant

For any specific information and for the firmware commands and procedures, please refer to the data sheet of the components.

.6.10 RGB LEDs Driver

The TLC59116 is an I²C bus controlled 16-channel LED driver that is optimized for red/green/blue/amber (RGBA) color mixing and backlight application. Each LED output has its own 8-bit resolution (256 steps) fixed-frequency individual PWM controller that operates at 97 kHz, with a duty cycle that is adjustable from 0% to 99.6%.

Features

- 16 LED Drivers (Each Output Programmable at Off, On, Programmable LED Brightness, or Programmable Group Dimming and Blinking Mixed With Individual LED Brightness)
- 16 Constant-Current Output Channels
- 256-Step (8-Bit) Linear Programmable Brightness Per LED Output Varying From Fully Off (Default) to Maximum Brightness Using a 97-kHz PWM Signal
- 256-Step Group Brightness Control Allows General Dimming [Using a 190-Hz PWM Signal From Fully Off to Maximum Brightness (Default)]
- 256-Step Group Blinking With Frequency Programmable From 24 Hz to 10.73 s and Duty Cycle From 0% to 99.6%
- Four Hardware Address Pins Allow 14 TLC59116 Devices to Be Connected to Same I²C Bus
- Four Software-Programmable I²C Bus Addresses (One LED Group Call Address and Three LED Sub Call Addresses) Allow Groups of Devices to Be Addressed at Same Time in Any Combination
- Software Reset Feature (SWRST Call) Allows Device to Be Reset Through I²C Bus
- Up to 14 Possible Hardware-Adjustable Individual I²C Bus Addresses Per Device, So That Each Device Can Be Programmed
- Open-Load and Overtemperature Detection Mode to Detect Individual LED Errors
- Output State Change Programmable on Acknowledge or Stop Command to Update Outputs Byte-by-Byte or All at Same Time (Default to Change on Stop)
- Output Current Adjusted Through an External Resistor
- Constant Output Current Range: 5 mA to 120 mA
- Maximum Output Voltage: 17 V
- 25-MHz Internal Oscillator Requires No External Components
- 1-MHz Fast-mode Plus (FMT) Compatible I²C Bus Interface With 30-mA High-Drive Capability on SDA Output for Driving High-Capacitive Buses

- Internal Power-On Reset
- Noise Filter on SCL and SDA Inputs
- No Glitch on Power-Up
- Active-Low Reset
- Supports Hot Insertion
- Low Standby Current
- 3.3-V or 5-V Supply Voltage
- 5.5-V Tolerant Inputs
- Offered in 28-Pin Thin Shrink Small-Outline Package (TSSOP) (PW) and 32-Pin Quad Flatpack No Lead (QFN)
- -40 °C to 85 °C Operation

Block Diagram

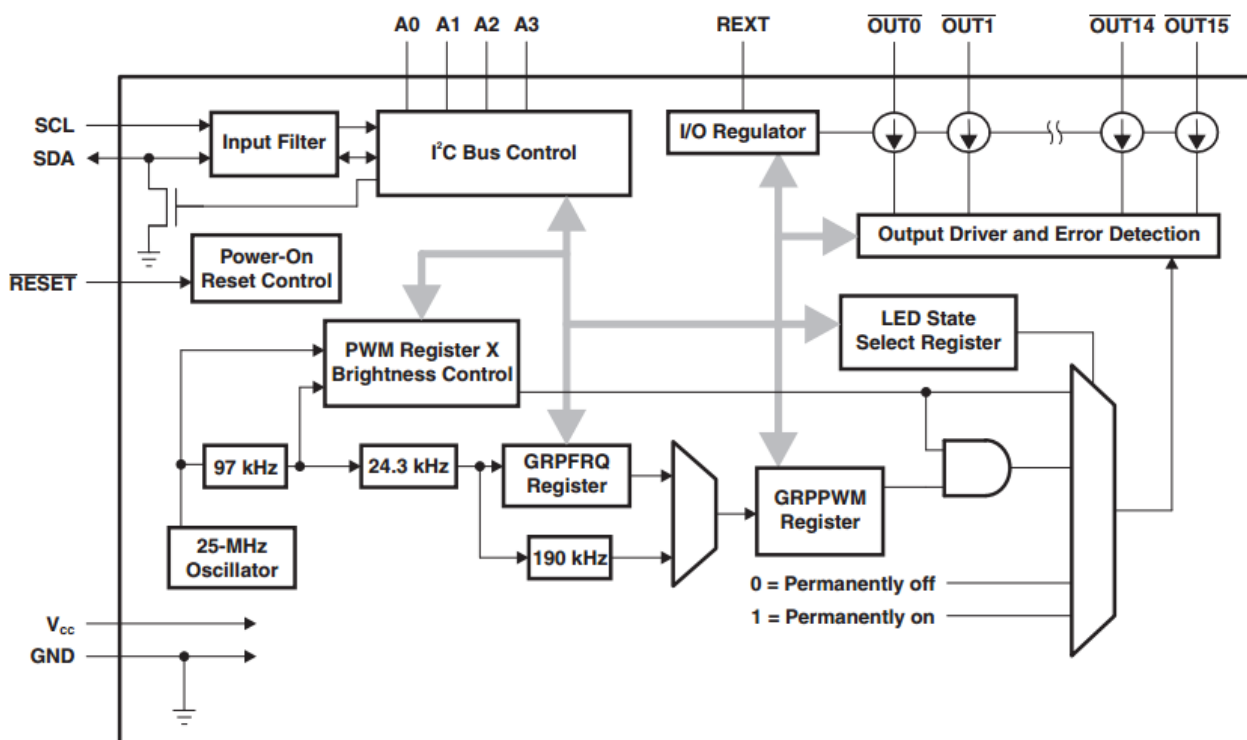

For any specific information and for the firmware commands and procedures, please refer to the data sheet of the components.

.6.11 LRA haptic motor Driver

The DRV2605 device is designed to provide extremely-flexible haptic control of ERM and LRA actuators over a shared I²C-compatible bus. This control relieves the host processor from ever generating pulse-width modulated (PWM) drive signals, saving both costly timer interrupts and hardware pins.

The DRV2605 device provides an extensive integrated library over 100 licensed effects from Immersion for ERM and LRA which eliminates the need to design haptics waveforms.

The DRV2605 device offers a licensed version of the TouchSense 2200 software from Immersion, which includes the 2200 Effects Library, and 2200 audio-to-vibe features. Additionally, the real-time playback mode

allows the host processor to bypass the library playback engine and play waveforms directly from the host through I²C.

The DRV2605 device also contains a smart-loop architecture, which allows effortless auto resonant drive for LRA as well as feedback-optimized ERM drive. This feedback provides automatic overdrive and braking, which creates a simplified input waveform paradigm as well as reliable motor control and consistent motor performance. The audio-to-haptics mode automatically converts an audio input signal to meaningful haptic effects.

The DRV2605 device features a trinary-modulated output stage, providing greater efficiency than linear-based output drivers. The 9-ball WCSP footprint, flexible operation, and low component count make the DRV2605 device the ideal choice for portable and touch-enabled vibratory and haptic applications.

Features

- Flexible Haptic/Vibra Driver
 - LRA (Linear Resonance Actuator)
 - ERM (Eccentric Rotating Mass)
- I²C Controlled Digital Playback Engine
 - Real-Time Playback Mode via I²C
- Smart Loop Architecture⁽¹⁾
 - Automatic Overdrive/Braking (ERM/LRA)
 - Automatic Resonance Tracking (LRA)
 - Automatic Actuator Diagnostic (ERM/LRA)
 - Automatic Level Calibration (ERM/LRA)
- Licensed Immersion™ TouchSense® 2200 features:
 - Integrated Immersion Effect Library
 - Audio to Vibe
- Optional PWM Input with 0% to 100% Duty Cycle Control Range
- Optional Analog Input Control
- Optional Hardware Trigger Pin
- Efficient Output Drive
- Fast Start Up Time
- Constant Acceleration Over Supply Voltage
- 1.8 V Compatible, VDD Tolerant Digital Pins

Block Diagram

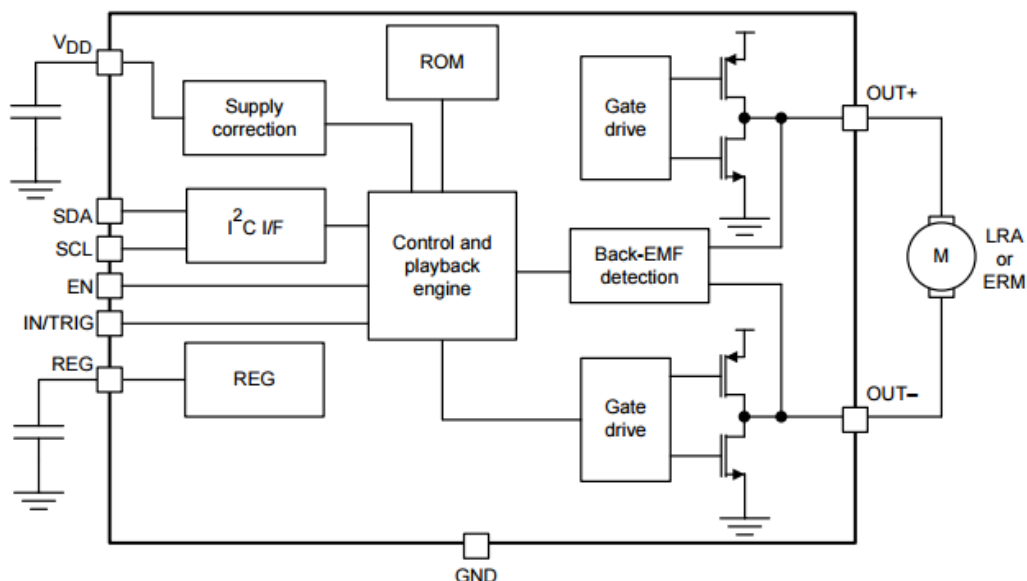

.6.12 Capacitive touch

The AT42QT1050 (QT1050) is a QTouchADC sensor driver. The device can sense from one to five keys, dependent on mode.

The QT1050 includes all signal processing functions necessary to provide stable sensing under a wide variety of changing conditions, and the outputs are fully debounced. Only a few external parts are required for operation and no external Cs capacitors are required.

The QT1050 modulates its bursts in a spread-spectrum fashion in order to heavily suppress the effects of external noise, and to suppress RF emissions. The QT1050 uses a QTouchADC method of acquisition. This provides greater noise immunity and eliminates the need for external sampling capacitors, allowing touch sensing using a single pin.

.6.13 Audio codec

The SGTL5000 is a Low Power Stereo Codec with Headphone Amp from Freescale, and is designed to provide a complete audio solution for products needing LINEIN, MIC_IN, LINEOUT, headphone-out, and digital I/O.

Deriving its architecture from best in class, Freescale integrated products that are currently on the market. The SGTL5000 is able to achieve ultra low power with very high performance and functionality, all in one of the smallest footprints available. Target markets include media players, navigation devices, smart phones, tablets, medical equipment, exercise equipment, consumer audio equipment, etc. Features such as capless headphone design and an internal PLL help lower overall system cost.

Features

- Analog Inputs
 - Stereo LINEIN - Support for external analog input
 - Stereo LINEIN - Codec bypass for low power
 - MIC bias provided
 - Programmable MIC gain
 - ADC - 85 dB SNR (-60 dB input) and -73 dB THD+N (VDDA = 1.8 V)
- Analog Outputs
 - HP Output - Capless design
 - HP Output - 62.5 mW max, 1.02 kHz sine into 16 Ω load at 3.3 V
 - HP Output - 100 dB SNR (-60 dB input) and -80 dB THD+N (VDDA = 1.8 V, 16 Ω load, DAC to headphone)
 - LINEOUT - 100 dB SNR (-60 dB input) and -85 dB THD+N (VDDIO = 3.3 V)
- Digital I/O
 - I2S port to allow routing to Application Processor
- Integrated Digital Processing
 - Freescale surround, Freescale bass, tone control/ parametric equalizer/graphic equalizer clocking/control
 - PLL allows input of an 8.0 MHz to 27 MHz system clock - standard audio clocks are derived from PLL
- Power Supplies
 - Designed to operate from 1.62 to 3.6 volts

Note: To make the sgtl5000 codec running you need a working Linux device driver for it loaded in ARTIK.

Block diagram

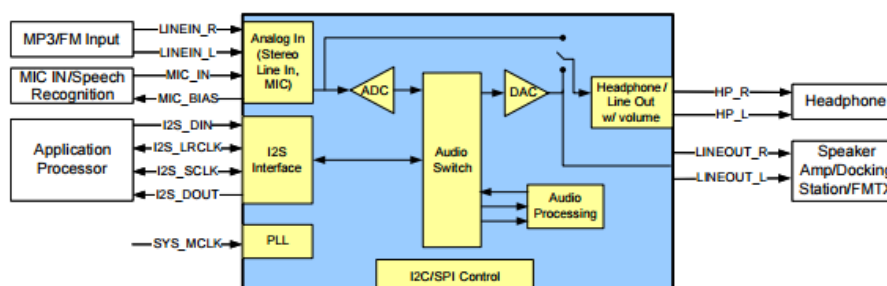

Note: SPI is not supported in the 3.0 mm x 3.0 mm 20-pin QFN package

Figure 1. SGTL5000 Simplified Application Diagram

Schematics

Section of the audio codec and the class D power amplifiers

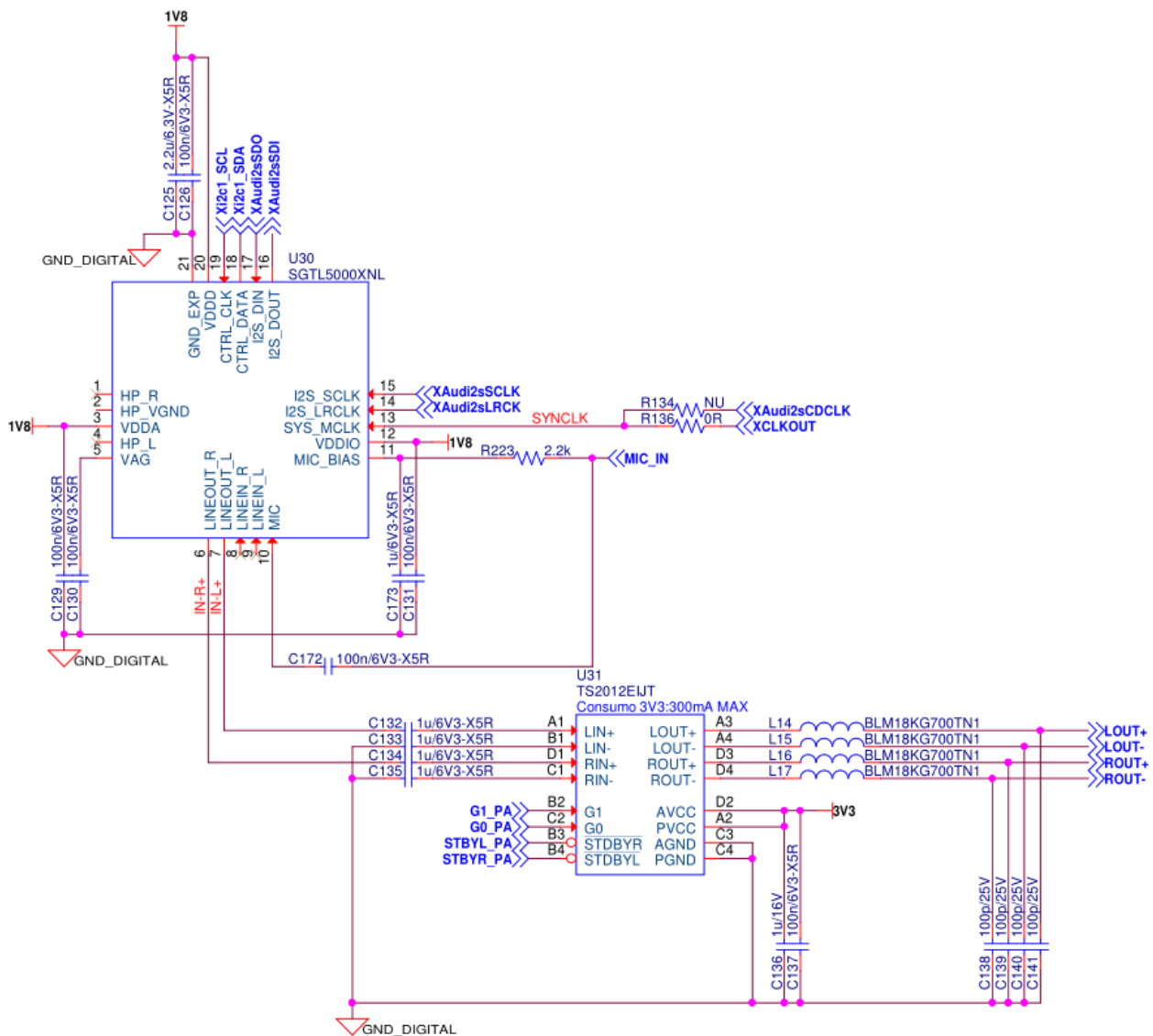

PIN NAME CLASS D POWER AMPLIFIERS	ARTIK 520-SIDE
G1_PA	J23-26
G0_PA	J23-28
STBYL_PA	J23-30
STBYR_PA	J23-32

.7 EXTERNAL MULTIMEDIA ACCESSORIES

.7.1 DISPLAY

Supported models: [PA320320A](#), X163QLN01.

Power down the Kitra520 before any plugging.
Prepare the display and the Kitra520 board with Artik520 mounted.

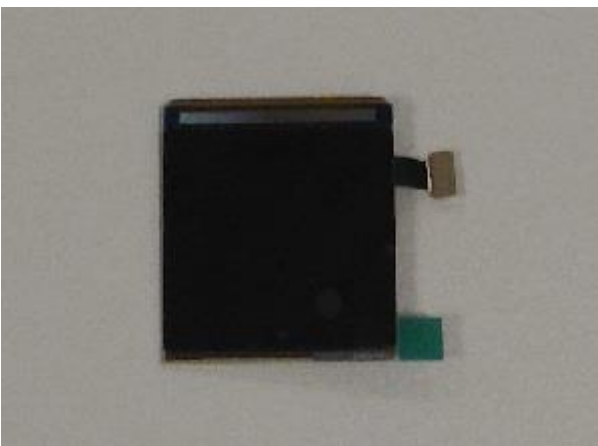

Gently plug the connector on the board

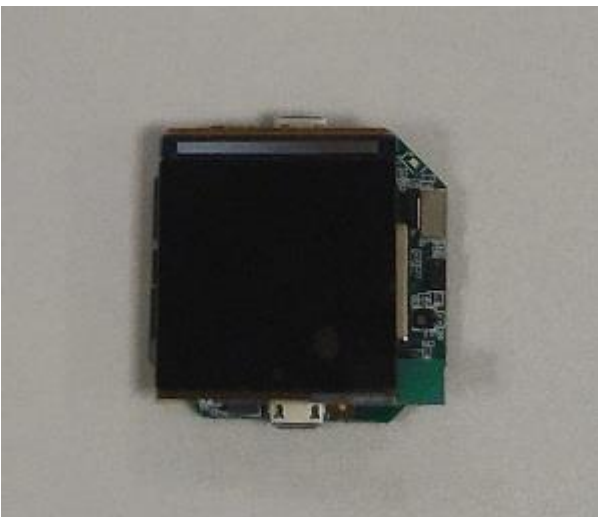

The display connector is not polarized, pay attention to plug it into the board as indicated in the above picture, otherwise failure may occur.

.7.2 CAMERA

Supported model: [LI-OV5640-MIPI-AF](#)

Power down the Kitra520 before any plugging.
Prepare the Kitra520 board and the camera.

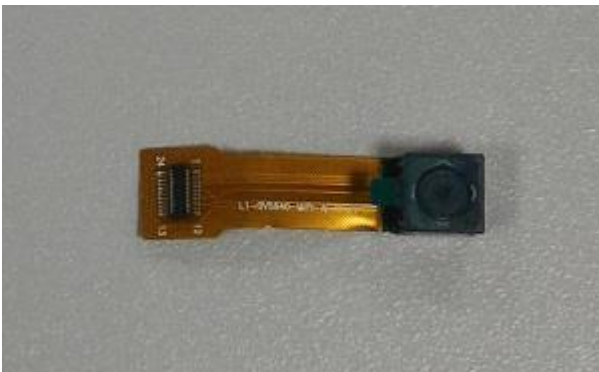

Gently plug the connector on the board

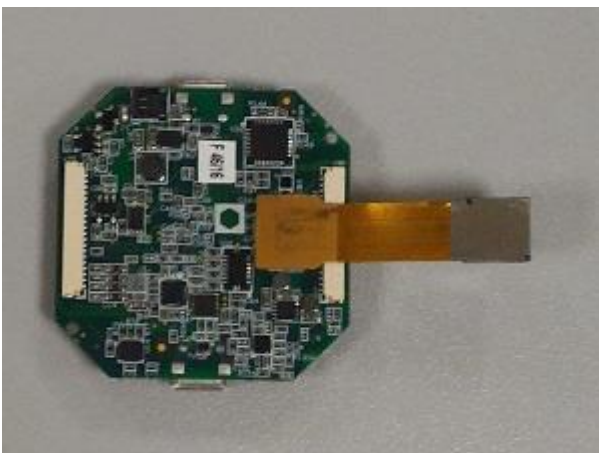

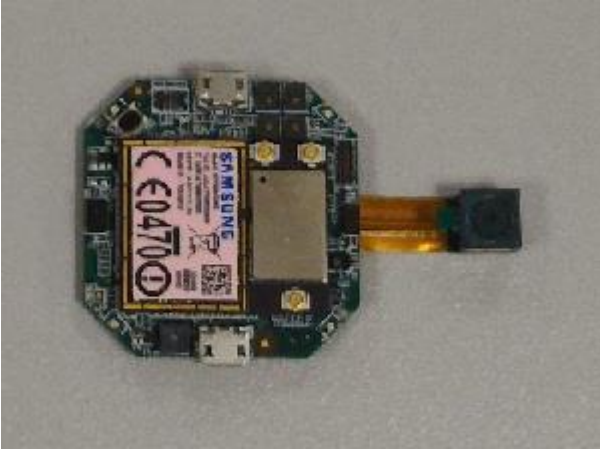

The camera connector is not polarized, pay attention to plug it into the board as indicated in the above picture, otherwise failure may occur.

.8 EXPANSIONS CONNECTOR

To connect external devices KITRA 520 has two connectors, as show below.

FUNCTIONAL NOTES ON EXPANSION CONNECTOR LINES

- Lines DOUT1-PWM/DOUT2/DOUT3/DOUT4-PWM have 330ohm internal resistor so maximum current per output is 10mA.
- Lines DIN1/DIN2/DIN3/DIN4 have 330ohm series resistor and after those have 10kohm internal pull up.
- Lines ANI_1/ANI_2/ANI_3/ANI_4 have 10kohm pull down and don't have protection series resistor, the lines are directly connected to the port pin of the microcontroller STM32F411.
- I2C1_SDA/I2C1_SCL have 2,2kohm internal pull up to 3,3V. This digital communication interface is connected to STM32F411 and to internal circuits also (LRA motor control, capacitive touch inputs, pressure sensor, humidity sensor, RGB LED controller, proximity sensors).

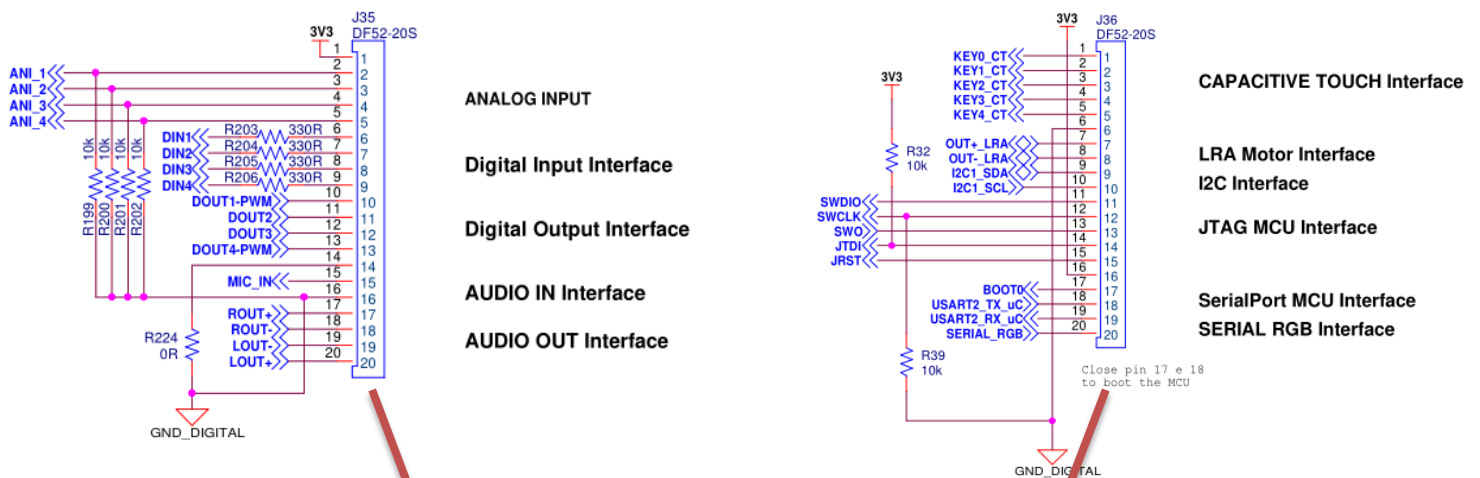

Pin 1

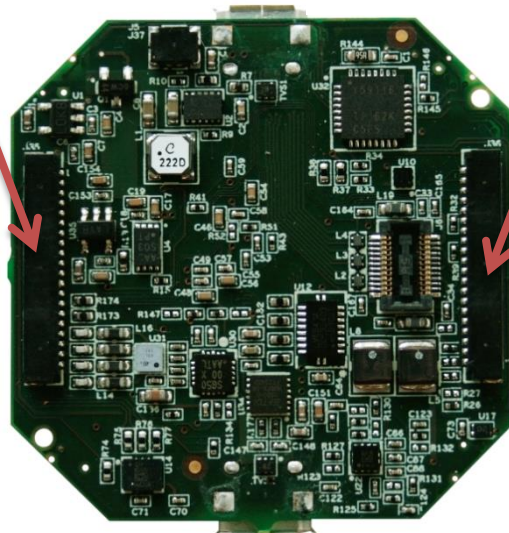

Pin 1

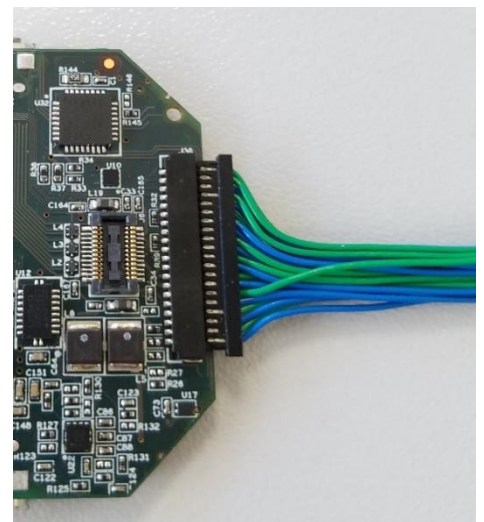
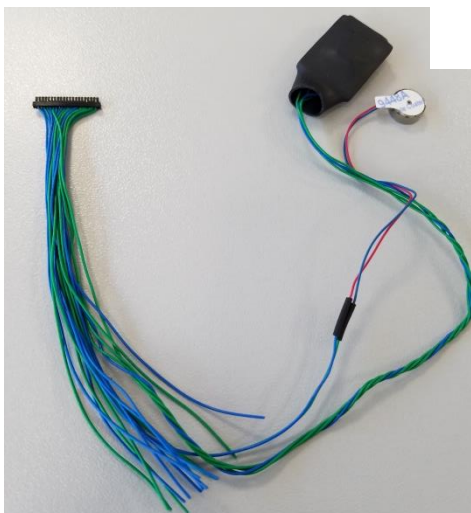

.9 EXPANSION CONNECTORS PINS TABLE

PIN NAME	CONNECTOR REF.	DESCRIPTION	SPECIFICATIONS
ANI_1	J35.2	Analog input 1	12 bit resolution. 3,3V absolute maximum range of analog voltage input. 10kohm pull down.
ANI_2	J35.3	Analog input 2	12 bit resolution. 3,3V absolute maximum range of analog voltage input. 10kohm pull down.
ANI_3	J35.4	Analog input 3	12 bit resolution. 3,3V absolute maximum range of analog voltage input. 10kohm pull down.
ANI_4	J35.5	Analog input 4	12 bit resolution. 3,3V absolute maximum range of analog voltage input. 10kohm pull down.
DIN1	J35.6	Digital input 1	3,3V absolute maximum range of digital voltage input. 10kohm pull up to internal 3,3V 330ohm series resistor.
DIN2	J35.7	Digital input 2	3,3V absolute maximum range of digital voltage input. 10kohm pull up to internal 3,3V 330ohm series resistor.
DIN3	J35.8	Digital input 3	3,3V absolute maximum range of digital voltage input. 10kohm pull up to internal 3,3V 330ohm series resistor.
DIN4	J35.9	Digital input 4	3,3V absolute maximum range of digital voltage input. 10kohm pull up to internal 3,3V 330ohm series resistor.
DOUT1-PWM1	J35.10	Digital output 1 and pwm 1	3,3V voltage level of the digital output. 330ohm series resistor.
DOUT2	J35.11	Digital output 2	3,3V voltage level of the digital output. 330ohm series resistor.
DOUT3	J35.12	Digital output 3	3,3V voltage level of the digital output. 330ohm series resistor.
DOUT4-PWM2	J35.13	Digital output 4 and pwm 2	3,3V voltage level of the digital output. 330ohm series resistor.
MIC_IN	J35.15	External microphone	
ROUT+	J35.17	External speaker	See TS2012EIJT data sheet and consider that KITRA 520 power the class D audio amplified with 3,3V.
ROUT-	J35.18	External speaker	See TS2012EIJT data sheet and consider that KITRA 520 power the class D audio amplified with 3,3V.
LOUT+	J35.20	External speaker	See TS2012EIJT data sheet and consider that KITRA 520 power the class D audio amplified with 3,3V.
LOUT-	J35.19	External speaker	See TS2012EIJT data sheet and consider that KITRA 520 power the class D audio amplified with 3,3V.
KEY0_CT	J36.1	Capacitive touch key 0	-
KEY1_CT	J36.2	Capacitive touch key 1	-
KEY2_CT	J36.3	Capacitive touch key 2	-

KEY3_CT	J36.4	Capacitive touch key 3	-
KEY4_CT	J36.5	Capacitive touch key 4	-
OUT+_LRA	J36.7	Motor	ERM and LRA actuators can be used. Refer to paragraph 6.11.
OUT-_LRA	J36.8	Motor	ERM and LRA actuators can be used. Refer to paragraph 6.11.
I2C1_SDA	J36.9	I2C1 bus external access	2,2kohm pull up to internal 3,3V.
I2C1_SCL	J36.10	I2C1 bus external access	2,2kohm pull up to internal 3,3V.
SWDIO	J36.11	For JTAG	Connected to STM32F411.
SWCLK	J36.12	For JTAG	Connected to STM32F411.
SWO	J36.13	For JTAG	Connected to STM32F411.
JTDI	J36.14	For JTAG	Connected to STM32F411.
JRST	J36.15	For JTAG	Connected to STM32F411.
BOOT0	J36.17	For MCU serial programming	3,3V logic input.
USART2_TX_uC	J36.18	Independent USART	3,3V OUTPUT
USART2_RX_uC	J36.19	Independent USART	3,3V INPUT
SERIAL_RGB	J36.20	Not used	-

IMPORTANT NOTE

USART2 can be used as serial COM in boot mode for STM32F411 when BOOT0 pin is at 3,3V level after power on. If pin BOOT0 is low level (0V) after power on, USART2 can be used as normal serial COM. Please, don't use this port for KITRA-COM firmware upgrade, follow the dedicated procedure using Samsung ARTIK 520 script. The specific process for MCU firmware upgrade in case of a new KITRA-COM release is defined by a specific document that can be found on: <https://github.com/rushup/kitra520>

.10 GETTING STARTED AND DEVELOPMENT WITH KITRA 520

.10.1 KITRA-COM

KITRA 520 is shipped with a preloaded KITRA-COM firmware. The firmware is enough for most cases, so you may not need to develop on the STM32 microcontroller.

Check the KITRA-COM manual for a detailed introduction to the communication protocol between KITRA 520 and ARTIK.

Using the KITRA-COM firmware all the development is done by running an application on ARTIK that communicates with the serial, like Node-RED or a custom application written in any language you like.

If necessary you can also build a custom firmware for KITRA 520 to match your needs, in this case you need:

- ST-LINK debugger
- Mini-USB cable
- Custom cable to match the ST-LINK connector and the KITRA 520 pins (as shown in [Expansions connectors](#)). This is required for debugging and programming.

It is also possible to program a board through the external serial by closing the BOOT0 pin, check [Flash Loader Demonstrator](#).

For KITRA 520 Schematics please contact us at info@rushup.tech to sign the NDA.

.10.2 Board reference

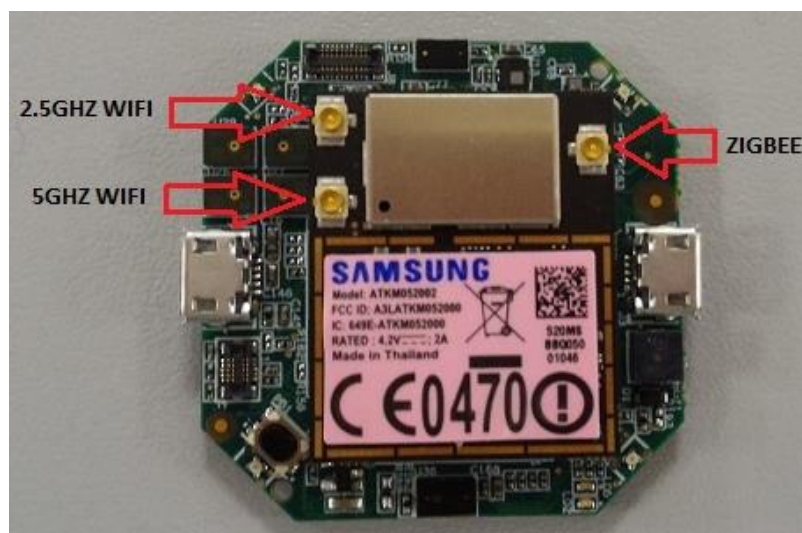
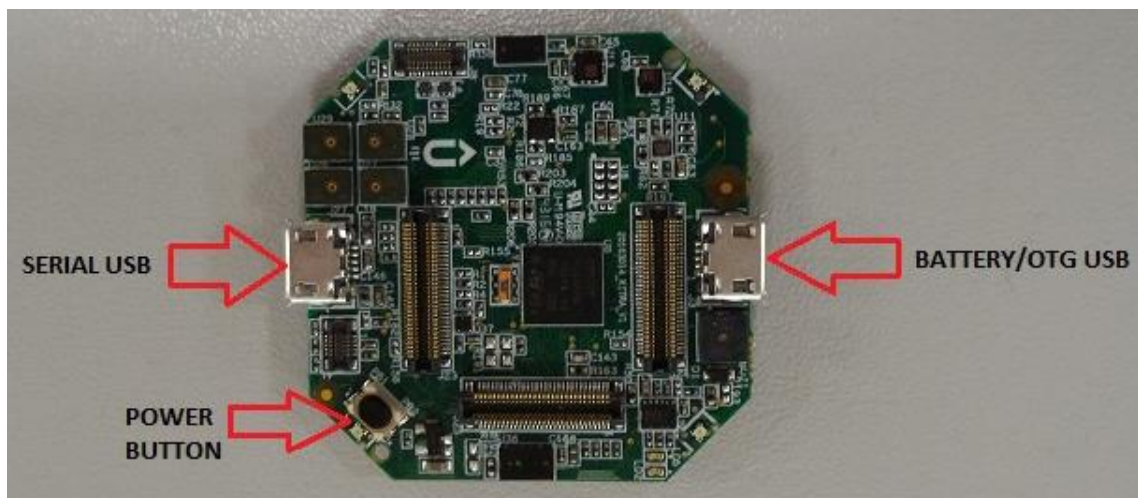

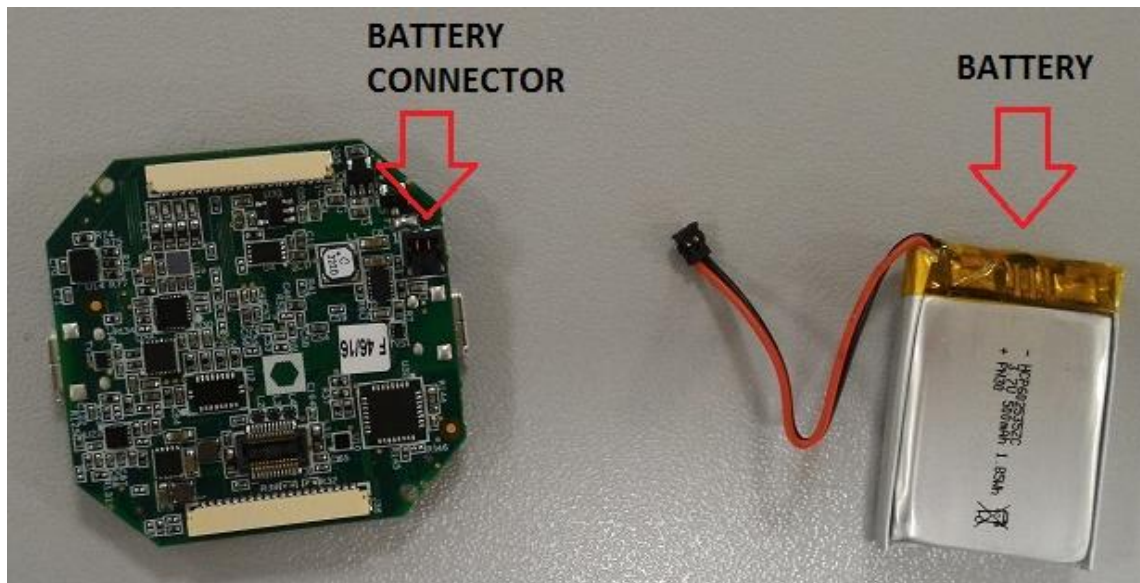

.10.3 First steps

.10.3.1 Hardware required

- Artik 520 IoT module with Fedora preloaded
- Kitra board with battery
- Wireless antennas (for Wi-Fi dual band, Bluetooth and Zigbee)
- 2 micro-usb cables
- 1 PC
- Wi-Fi access point with internet connection

.10.3.2 Software required

- FT232 Virtual COM port driver (<http://www.ftdichip.com/Drivers/D2XX.htm>)

.10.3.3 First setup

We recommend charging the battery of the KITRA 520 board before doing anything.

The micro-usb reserved for charging is the one close to the battery wires (indicated in the picture above as BATTERY USB). When the battery is charged, battery LED will be off.

1. All micro-usb cables must be unplugged
2. Plug onto KITRA 520 the Artik 520 IoT module.
3. Plug the antenna
 - **Caution:** Do not apply power (enable) the radio chips before connecting antennas or damage to the chip may result.
 - **5GHz Wi-Fi prescription:** In the frequency band 5150-5350 MHz, the use of the KITRA 520 with Wi-Fi wireless communications are restricted to indoor use only.



4. Plug the battery to the KITRA 520 board and **secure it to the housing of the product.**
 - **IMPORTANT SAFETY NOTE: do not let the battery connected dangling!**
Since the battery is connected to the KITRA 520 board through the connector it is mandatory that the battery is mechanically fastened to the an external support because the KITRA 520 battery connector cannot act as mechanical holder otherwise the battery connections can be damaged and cause the battery cable short circuit with potential damage of the board.
 - **IMPORTANT BATTERY SAFETY NOTE:**
Since the KITRA 520 board in continuous operation can generate an overheating of its surface, it is prohibited to attach the lithium battery directly to the surface of the electronic boards otherwise the battery could be damaged. It's important to respect the temperature limits specified for both the battery and the KITRA 520 or damage of the battery and/or the board may result.



5. Plug the micro-usb battery cable if you want to prevent discharging of the battery.
6. Push the power button on the KITRA 520 for 2 seconds and then release it (you should hear a beep sound confirming that firmware has started).
7. Wait some seconds and then plug the debug micro-usb to a computer.

IMPORTANT FUNCTIONAL NOTE:

It's important to plug the debug usb cable AFTER you've powered on KITRA 520 the first time or you won't be able to attach any terminal. If you did that just unplug and replug the usb cable.

.10.4 Communicate with artik

.10.4.1 Setup guides needed

Guide for serial communication [click here](#) (Press enter in the terminal to see if it is working).

If you don't see any virtual COM port available, try installing "FT232 Virtual COM port driver" provided in the "Software required" paragraph.

If during the boot the system is stuck with an "**eth0: ff**" error, you have plugged an Artik that has not been purchased with the KITRA 520 board. To fix the issue we need to replace the dtb file, check the [Replacing the device tree via fastboot](#) guide.

- Guide for Wifi [click here](#)

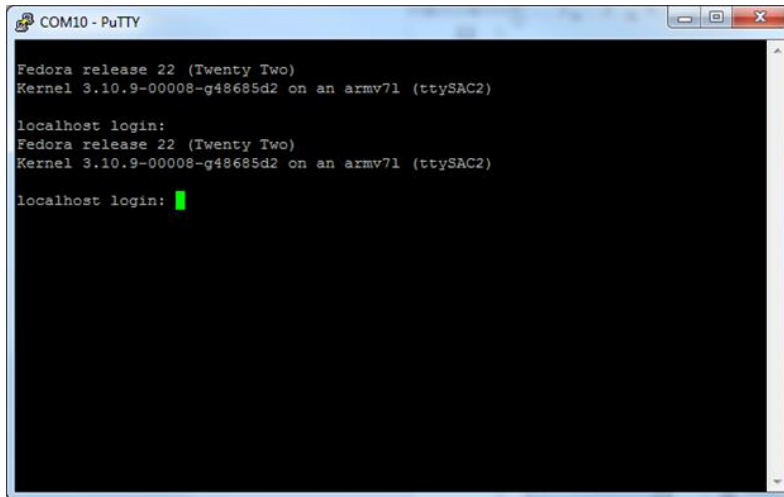

```
COM10 - PuTTY
Fedora release 22 (Twenty Two)
Kernel 3.10.9-00008-g48685d2 on an armv7l (ttySAC2)

localhost login:
Fedora release 22 (Twenty Two)
Kernel 3.10.9-00008-g48685d2 on an armv7l (ttySAC2)

localhost login: █
```

.10.4.2 Node red configuration (Fedora)

You need to install node, npm, node-red and node-red-contrib-kitra.

```
$ dnf update
$ dnf install node
$ dnf install npm
$ npm install -g node-red
$ npm install -g node-red-contrib-kitra
```

Node-red-kitra is a node-red extension to demonstrate kitra-com communication. Artik communicates with KITRA 520 through a serial protocol (kitra-com) with NMEA-style protocol. For more informations check the Kitra-COM document.

Check your ip address with `ifconfig wlan0` and write it down.

Now start node-red:

```
$ node-red
```

If you want to stop it, press ctrl-c

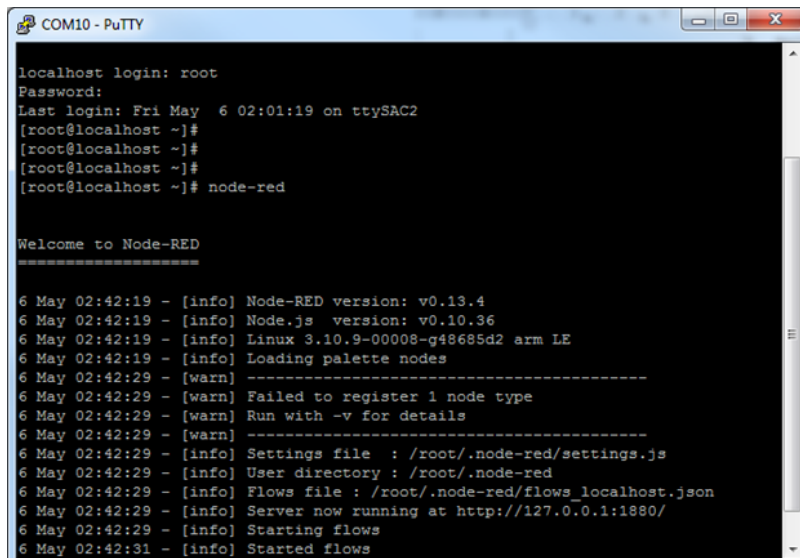

```
COM10 - PuTTY
localhost login: root
Password:
Last login: Fri May 6 02:01:19 on ttySAC2
[root@localhost ~]#
[root@localhost ~]#
[root@localhost ~]#
[root@localhost ~]#
[root@localhost ~]# node-red

Welcome to Node-RED
-----
6 May 02:42:19 - [info] Node-RED version: v0.13.4
6 May 02:42:19 - [info] Node.js version: v0.10.36
6 May 02:42:19 - [info] Linux 3.10.9-00008-g48685d2 arm LE
6 May 02:42:19 - [info] Loading palette nodes
6 May 02:42:29 - [warn] -----
6 May 02:42:29 - [warn] Failed to register 1 node type
6 May 02:42:29 - [warn] Run with -v for details
6 May 02:42:29 - [warn] -----
6 May 02:42:29 - [info] Settings file : /root/.node-red/settings.js
6 May 02:42:29 - [info] User directory : /root/.node-red
6 May 02:42:29 - [info] Flows file : /root/.node-red/flows_localhost.json
6 May 02:42:29 - [info] Server now running at http://127.0.0.1:1880/
6 May 02:42:29 - [info] Starting flows
6 May 02:42:31 - [info] Started flows
```

Open a browser and write in the url bar the address you wrote down before, adding :1880 in the end. You should see something like this:



If you already know Node-RED you should notice that new nodes were added in the list, under `kitra_input` and `kitra_output` category.

.10.5 Writing your own node-red application

After the installation of the `node-red-contrib-kitra` package, you will see at the left side panel a list of KITRA 520 nodes. Those help you parsing the communication to the KITRA 520 board.

KITRA 520 communicates with Artik through the serial-based KITRA-COM protocol, so the node-red module will create a string to send through the serial port or accept a string as input providing parsing and checksum calculations.

Node-red already has a module for handling serial communication, so you should use it to redirect output or input of KITRA 520 nodes.



As you can see, nodes split in three categories:

- *KITRA 520 input: nodes used to handle KITRA 520 to Artik messages*
- *KITRA 520 output: nodes used to handle Artik to KITRA 520 messages*
- **KITRA 520 utility: not used for messages, may help to handle some sensor-typical calculations **

(Ex. *adc conversion for ntc*)

To communicate with a peripheral those are usually the step to follow:

- Enable the peripheral
- Configure the peripheral
- Read/Set the peripheral value

With some peripheral is also possible to configure notifications, by configuring notification you will not need any additional reading command.

.10.6 LED example

.10.6.1 Enable/Configure

Drag into the flow an inject node, an output KITRA 520 enable node (in this example we are using a node used to enable a single rgb led) and a serial output node.

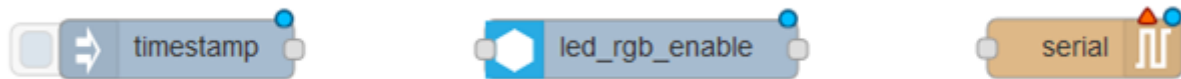

Note: inject nodes let your start a program cycle

.10.6.2 Attach them

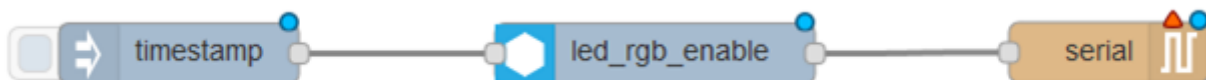

.10.6.3 Configure serial port

Double click on the serial node and configure it like this

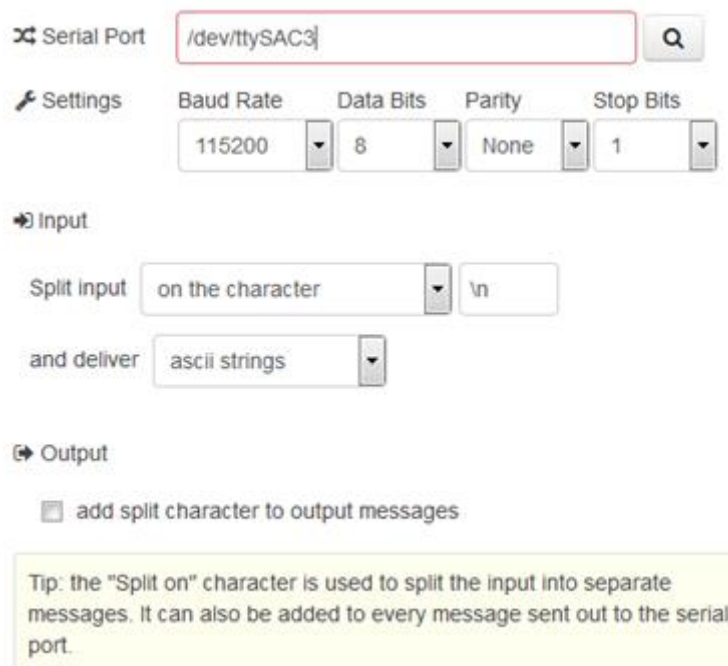

The screenshot shows the configuration window for the serial port. The 'Serial Port' field is set to '/dev/ttySAC3'. Under 'Settings', the Baud Rate is 115200, Data Bits is 8, Parity is None, and Stop Bits is 1. Under 'Input', 'Split input' is set to 'on the character' with '\n' as the character, and 'and deliver' is set to 'ascii strings'. Under 'Output', the checkbox 'add split character to output messages' is checked. A tip box at the bottom states: 'Tip: the "Split on" character is used to split the input into separate messages. It can also be added to every message sent out to the serial port.'

Note: /dev/ttySAC3 should be the default serial port used to communicate with KITRA 520, if you find issues try to check which serial ports are available in your Artik module

.10.6.4 Set led color

There is no configuration for this peripheral, skipping to set its value (that will allow us to set the color too)

Drag another inject node and the led_rgb_set node and attach everything together:

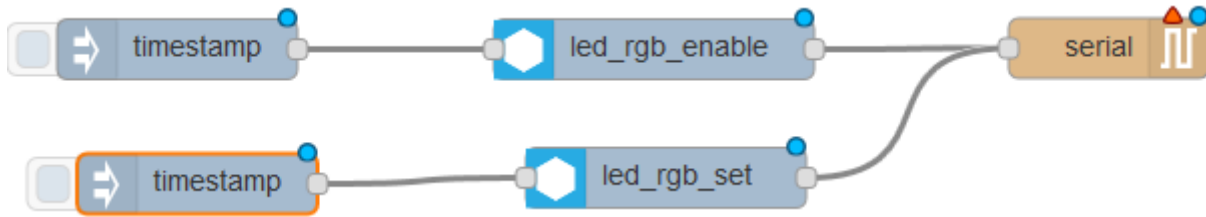

Double click led_rgb_set node

Edit led_rgb_set node

Name

Pin

Color

Intensity(%)

Autostart

Inset any 24bit hex color in the Color field and a value from 0 to 100 for the intensity field.\ Leave autostart as enabled and press Ok.

.10.6.5 Trying it out

Press the Deploy button on the top-right of the screen.



Now click the button of the first inject node:

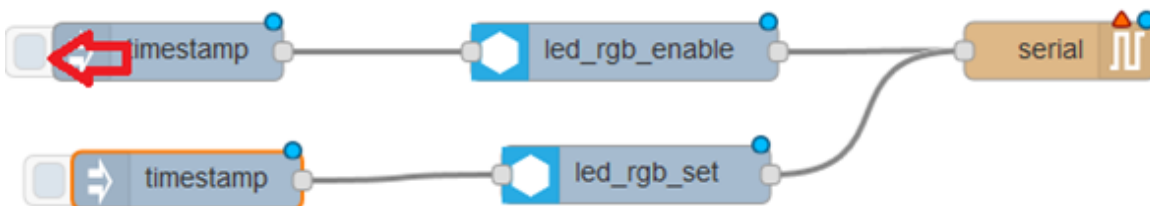

Doing so, you will enable an rgb led but you will see nothing.

Press now the other inject module and see what happens.

.10.6.6 See KITRA 520 response

KITRA 520 answers to every command with a response or an acknowledge, to see it add a serial input node and a debug node:

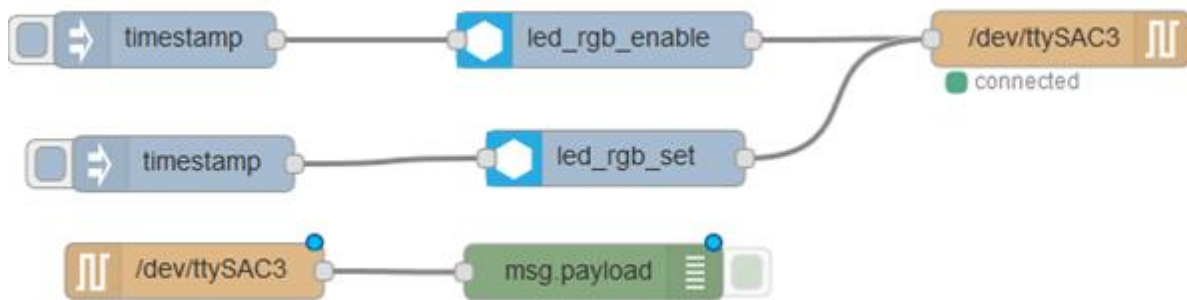

Note: remember to configure the serial input too, like the serial output

Re-deploy your flow and see KITRA 520's responses in the debug tab:



Receiving temperature, proximity or other values from KITRA 520 the procedure is very similar, instead to attach the serial port input node to a debug node, attach it to a KITRA 520 input node instead.

You will be able to see an example in the next chapter, showing you how to read a sensor value from KITRA 520 and sending it to the Artik cloud.

.10.7 Preparing artik.cloud

Before proceeding with the next example, we need to configure our artik cloud account.

Follow the artik cloud tutorial: [click here](#)

To create a manifest compatible with the next demo, create a new field called "prox1".

.10.8 Sensor example

Create the following flow:

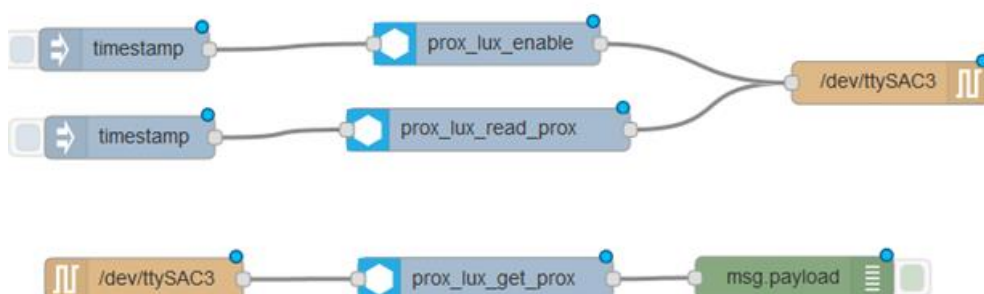

As you can see it is very similar to the led example, the main difference is that serial input node is plugged to the prox_lux_get_prox node.

This node uses the Kitra-COM message and outputs a clean proximity value.

Try to run it by pressing on the first inject node, and then the second.

You should see in the debug tab the proximity value in millimeters.

Put your hand on the top of the KITRA 520 board and send again the read command, you will see that it has a lower value.

Connecting to artik.cloud:

- 1) Remove the debug node
- 2) Drag a function node and attach it to the prox_lux_get_prox node
- 3) Double click on the function node, put the following code:

```
*msg.headers = { *
*"Content-Type": "application/json", *
*"Authorization": "Bearer [YOUR_DEVICE_ID]" *
};
*msg.payload = {"data": *
*{"prox1": msg.payload}, *
*"sdid": "[YOUR_ID]", *
*"type": "message" *
};
return msg;
```

- 1) Press ok
- 2) Drag an http request node and attach it to the function node



- 1) Double click on the http request module, and fill the url filed with:

<https://api.artik.cloud/v1.1/messages>

- 1) Now every proximity value received will be sent to artik.cloud

Note: you can issue automatic reading by double clicking on the inject node of the reading and setting the "Repeat" field to "interval".

.10.9 Other examples

You can find other node-red examples [here](#).

If you prefer C or other languages check this library: [kitra-com-lib](https://github.com/kitra-com-lib).

.10.10 Firmware upgrade

You may also be interested in upgrading the to the latest KITRA 520 firmware, check the [Firmware upgrade](#) guide.

.10.11 Turn off

1. To turn off ARTIK you must send the command *shutdown now* (via terminal or ssh for example)
2. To turn off KITRA 520 push the power button for 8 seconds until you hear the beep sound stopping. If you hear a double-beep that means you released the button too soon.

.10.12 Known issues

- If you plug the device before turning on the KITRA 520, you see no data coming from the Artik. In these case, you need to unplug the micro-usb, wait some seconds, plug again and restart the serial terminal session.

.11 SPECIFICATIONS

Parameter	Minimum	Typical	Maximum	Conditions
Power supply voltage for charger	4,5V	5V	5,5V	USB port input connector
Input current on USB power port	-	-	0,45A	During the charging of the battery
External USB power supply voltage		-	5,5V	Absolute maximum voltage of the USB Power Charger
External USB power supply current		-	0,5A	Current rating of the external USB Power Charger
Power supply from battery connector	3,5V	3,7V	4,2V	Li-Ion Polymer Rechargeable Battery
Operation temperature	0°C	-	45°C	Electronics board
Storage temperature	-20°C		60°C	Electronics board
Storage temperature	-20°C		45°C	Electronics board with battery for 1 month. Recommended storage of the Lithium battery is 23°C

Wireless standard	Frequency band low	Frequency band high	Transmitted power
Bluetooth	2402 MHz	2480 MHz	9,8 dBm
Wi-Fi	2412 MHz	2472 MHz	17,6 dBm
Wi-Fi	5150 MHz	5350 MHz	17,1 dBm
Wi-Fi	5470 MHz	5725 MHz	16,1 dBm
Wi-Fi	5725 MHz	5850 MHz	11,6 dBm
Zigbee	2405 MHz	2480 MHz	7,8 dBm

.12 MECHANICAL SPECIFICATIONS

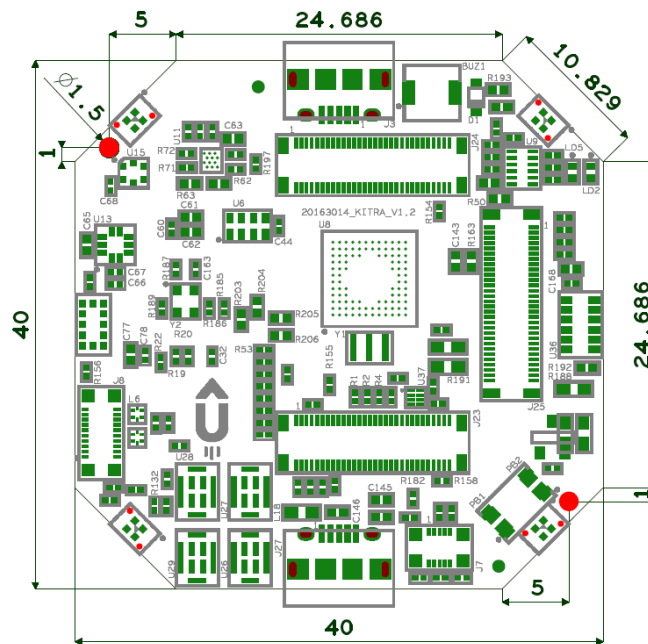

The measures are in mm and the view is TOP side.

.13 HOUSING PRESCRIPTION

KITRA 520 is PCBA (Printed Circuit Board Assembly) system and so it is not a final product, it's necessary to close the board in a specific housing or mechanical box.

The housing, in addition to achieve the desired functionality, must be fireproof (in case of unexpected failure of the electronic board component that produce a little spark, a fire will be blocked).

Lithium battery pack must be protected by external housing of the final product which KITRA board will be used

.14 PACKAGING OF THE STARTER KIT

Standard package of the KITRA 520 bundle kit is made up with the next items:

- KITRA 520 electronics board;
- Samsung ARTIK 520 module;
- Lithium rechargeable battery (500mAh capacity).;
- 2.4GHz uFL antenna;
- KITRA 520 expansion cable 200mm length.



.15 DECLARATION OF CONFORMITY

EU Declaration of Conformity (DoC)

We

Company name: FAE s.r.l.
 Postal address: C. Battisti 136
 Postcode: 24025
 City: Gazzaniga (Bg)
 Telephone number: +3903573180
 E-Mail address: info@faesrl.com

declare that the DoC is issued under our sole responsibility and belongs to the following product:

Apparatus model/Product: KITRA 520
 Type: IoT Electronics board based on Samsung ARTIK 520
 Batch: 520
 Serial number: From 000001 to 999999

Object of the declaration (identification of apparatus allowing traceability; it may include a colour image of sufficient clarity where necessary for the identification of the apparatus):



The object of the declaration described above is in conformity with the relevant Union legislation:

Directive 2014/53/EU (RED)

RED Directive 2014/53/EU

RoHS Directive 2011/65/EU

The following standards and technical specifications have been applied:

Title, Date of standard/specification:

EN 62311:2008	EN 300 328 V1.9.1:2015
EN 301 489-1 V1.9.2: 2011	EN 300 440-1 V1.6.1:2010+EN 300 440-2 V1.4.1:2010
EN 301 489-3 V1.6.1: 2013	EN 301 893 V1.8.1:2015
EN 301 489-17 V2.2.1: 2012	EN 300 328 V2.1.1:2016
EN 301 489-1 V2.2.0 (radiated immunity up to 6 GHz)	

Notified body (where applicable): Nemko S.p.A. 4 digit notified body number: 2051

Reference number of the certificate of notified body: 319829 dated 2017/04/28

Additional information:

Signed for and on behalf of: Gazzaniga (Bg)-Italy	2017/04/28	Gianmarco Lanza, CEO,
Place of issue	Date of issue	Name, function, signature

.16 IMPORTANT NOTES

- The battery connector mounted on KITRA 520 board is the Molex Pico-EZmate™ type. The connection has durability (mating cycles max) of maximum 10 cycles then use ON/OFF button for power off KITRA 520 instead of unplug the battery.
- Lithium battery pack must be protected by external housing of the final product which KITRA 520 board will be used.
- The USB battery charger embedded in the KITRA 520 generate 400mA of constant current during the charging phase then consider this for active state power consumption analysis and for battery selection in the final application/product.
- The KITRA 520 should not always be charged otherwise the battery may be damaged.
- The final application developed with KITRA 520 must be checked for correct battery selection. The KITRA 520 includes a lot of sensors and circuits and can also handle external peripherals (eg camera, displays and speakers). Therefore the current required by the battery must be checked against the battery data sheet to prevent that the current required by the application exceeds the battery discharge limit and avoid a damage of the battery. The battery included in the starter kit is intended to allow the start of development and be able to work with low power applications and is not suitable for use with high current consumption applications. Maximum current discharge of the battery included in the started kit is 500mA.
- External USB battery charger must have this features:
 - 5V USB standard voltage output
 - Between 0,5A maximum current output

.17 INDOOR USE ONLY FOR 5GHZ BAND

In the frequency band 5150-5350 MHz, the use of the KITRA 520 with Wi-Fi wireless communications is restricted to indoor use only.

.18 OPERATING ENVIRONMENT

The operating environment excludes special environments (extreme temperatures, dust, humidity, vibrations, flammable gases, corrosive or explosive atmosphere, etc.).

.19 DISCLAIMERS

RUSHUP RESERVES THE RIGHT TO CHANGE PRODUCTS, INFORMATION AND SPECIFICATIONS WITHOUT NOTICE.

Products and specifications discussed herein are for reference purposes only. All information discussed herein is provided on an "AS IS" basis, without warranties of any kind. This document and all information discussed herein remain the sole and exclusive property of Rush Up. No license of any patent, copyright, mask work, trademark or any other intellectual property right is granted by one party to the other party under this document, by implication, estoppel or other-wise.

Rush Up products are not intended for use in life support, critical care, medical, safety equipment, or similar applications where product failure could result in loss of life or personal or physical harm, or any military or defense application, or any governmental procurement to which special terms or provisions may apply. For updates or additional information about Rush Up products, contact Rush Up office. All brand names, trademarks and registered trademarks belong to their respective owners.

Rush Up is a trademark of FAE srl.

X-ON Electronics

Largest Supplier of Electrical and Electronic Components

Click to view similar products for [System-On-Modules - SOM category](#):

Click to view products by [RushUp manufacturer](#):

Other Similar products are found below :

[COMX-CORE-310](#) [COMX-P4040-4G-ENP2](#) [PICOIMX6U10R1GBNI4G](#) [PICOIMX6U10R1GBNI4GBW](#) [MC27561-TIGER](#) [MC27561-LION](#) [CC-WMX6UL-SMPL](#) [CB-52-PUS-110-SX](#) [BD63725BEFV-EVK-002](#) [5728-PJ-4AA-RI](#) [A00150](#) [COMX_P4080](#) [A20-SOM-EVB](#) [RK3188-SOM](#) [RK3188-SOM-4GB](#) [100-1225-1](#) [PICOIMX6Q10R1GBNI4G](#) [Nit6Q](#) [A20-SOM-N8GB](#) [PER-TAICX-A10-001](#) [PER-TAIX2-A10-2280](#) [EDL-mPCIe-MA2485](#) [SOM-5897C7-U0A1E](#) [SOM-6896C7-U2A1E](#) [SCM180-Dual-2G_Industrial](#) [3354-HX-X38-RC](#) [5728-PJ-4AA-RC](#) [6455-JE-3X5-RC](#) [Morph-IC-II](#) [ET876-X7LV](#) [IFC6301-10-P2](#) [IFC6502-00-P1](#) [IFC67A1-00-P1](#) [IFC6701-00-P1](#) [iW-G33M-SCMQ-4L002G-E008G-BII](#) [PWSE1000200B](#) [CS-DEPTHAI-04](#) [MTQ-LNA7-B02](#) [MYC-C8MMQ6-8E2D-180-C](#) [MYD-C4378-4E512D-100-I](#) [MOD5213-100IR](#) [A20-SOM](#) [A20-SOM204-1G](#) [A20-SOM204-1GS16ME16G-MC](#) [AM3352-SOM-EVB](#) [BS1-IC](#) [BS2-IC](#) [102110278](#) [SLS16Y2_792C_256R_256N_0SF_I](#) [SLS12RT52_528C_0R_4QSPI_0SF_I](#)