

RUSHUP

KITRA 710C

Data sheet

29/10/2018



Summary

.1	REVISION HISTORY	2
.2	KITRA 710C IMAGES	3
.3	INTRODUCTION	4
.4	DESCRIPTION	4
.5	HARDWARE & COMPONENTS DETAIL	4
.5.1	Samsung ARTIK 710 module	4
.5.2	Accelerometers - Magnetometers Sensors	6
.5.3	Accelerometers - Gyroscopes Sensors	6
.5.4	Barometer/Pressure sensor	7
.5.5	Proximity sensor	8
.5.6	ETHERNET	9
.5.7	HDMI	9
.5.8	USB HOST 2.0	9
.5.9	USB OTG	9
.5.10	USB to serial (UART) converter	9
.5.11	SD CARD	9
.6	BOARD CONNECTORS	9
.6.1	POWER SUPPLY CONNECTOR	10
.6.2	EXPANSIONS CONNECTOR	11
.6.3	ANTENNA CONNECTORS	13
.7	LEDS	14
.8	BUTTON	14
.9	BOOTING SEQUENCE	14
.10	KITRA 710C DEVELOPMENT BOARD BOOTING	14
.11	RF ELECTRICAL SPECIFICATIONS	16
.12	SPECIFICATIONS	22
.13	MECHANICAL SPECIFICATIONS	22
.14	HOUSING PRESCRIPTION	22
.15	PACKAGING (STARTER KIT)	23
.16	EU REGULATORY DISCLOSURES	23
.17	OPERATING ENVIRONMENT	23
.18	DICLAIMERS	23

.1 REVISION HISTORY

Date	Revision	Description
21/08/2017	0.1	Draft version
23/10/2017	0.2	Expansion connector image modified
25/11/2017	0.3	Removed humidity sensor description
13/01/2018	1	First release
29/10/2018	1.1	Images, DoC updates and RF specs

.2 KITRA 710C IMAGES

TOP VIEW

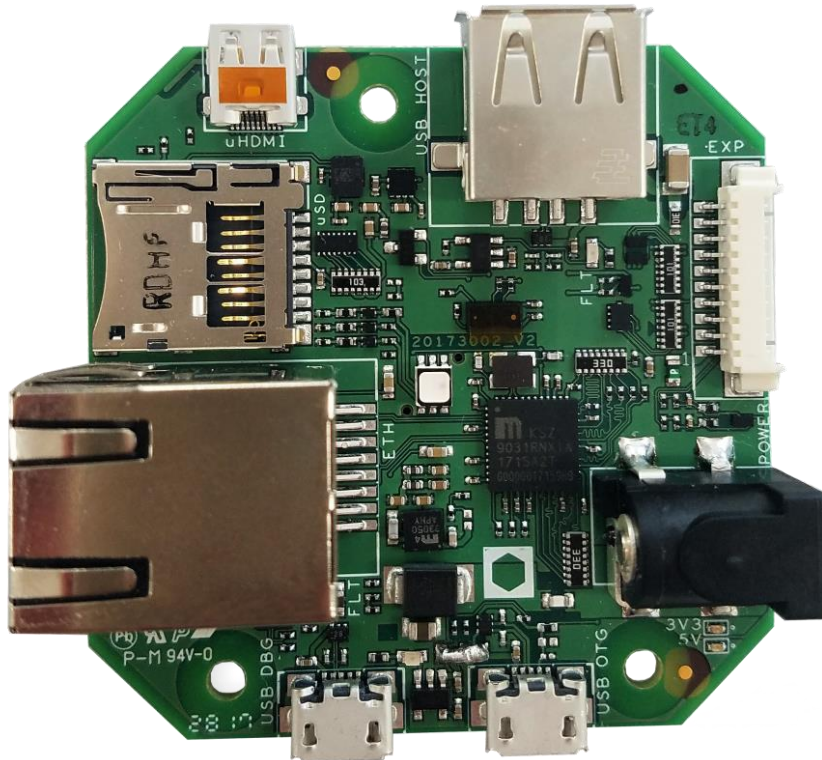

BOTTOM VIEW



.3 INTRODUCTION

This data sheet provides the description of the KITRA 710C board.

KITRA is a family of boards and includes a set of carrier boards for Samsung ARTIK modules, KITRA 710C is a carrier board of the Samsung ARTIK 710 module.

As RushUp electronics platform, KITRA 710C is a product accelerator and can be used from makers, developers, high mix low volume products and from all who want the benefit of an off the shelf industrialized board and doesn't have time and/or money to invest in a custom solution.

For details about RushUp and ARTIK, please visit:

www.rushup.tech

www.artik.io

.4 DESCRIPTION

KITRA 710C is the product accelerator for IoT Industry 4.0, factory automation, smart home gateway, multimedia applications, video cameras and home appliances and includes multicore processing, memories, crypto, sensors, communication interfaces and GPIO, as well as the power supply circuits.

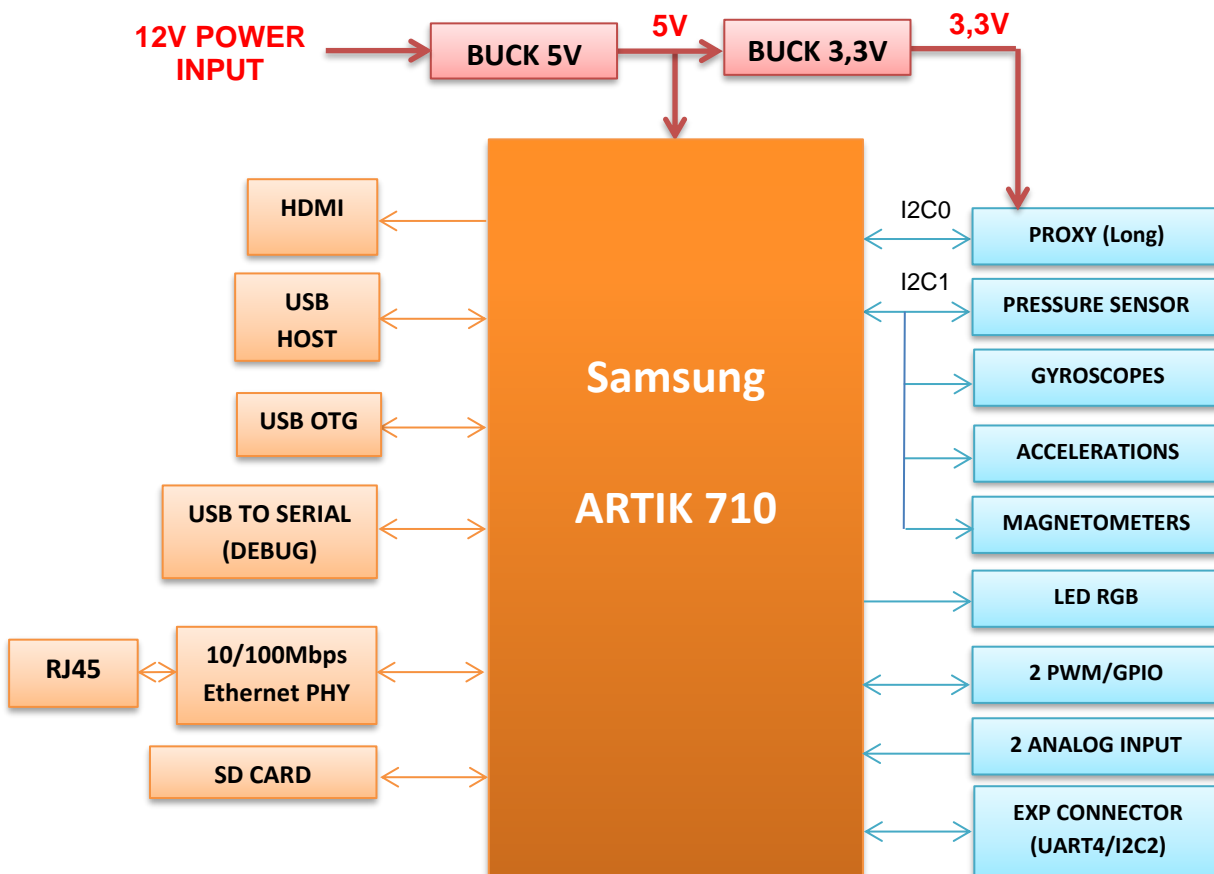

.5 HARDWARE & COMPONENTS DETAIL

.5.1 Samsung ARTIK 710 module

Samsung ARTIK 710 is the module of the KITRA 710C board and it embeds four specific functions:

- Processing;
- Memory;
- Wireless;
- Data security.

Samsung's ARTIK™ 710 Module is a highly-integrated System in-Module that utilizes an octa-core ARM® Cortex® -A53 processor packaged DRAM and Flash memory, a hardware Secure Element and a wide range of wireless communication options such as 802.11a/b/g/n/ac, Bluetooth® 4.1 (Classic+BLE), and 802.15.4 (ZigBee® or Thread) communications all into an extremely compact footprint. The many standard digital control interfaces support external sensors and higher performance peripherals to expand the module's

capabilities. With the combination of Wi-Fi, Bluetooth, ZigBee/Thread, the ARTIK 710 Module is the perfect choice for home automation and home hub devices, while also supporting a rich UI/UX capability with the camera and display support options. The hardware based Secure Element works with the ARM® TrustZone® and Trustware’s Trusted Execution Environment (TEE) to provide enhanced end-to-end security.

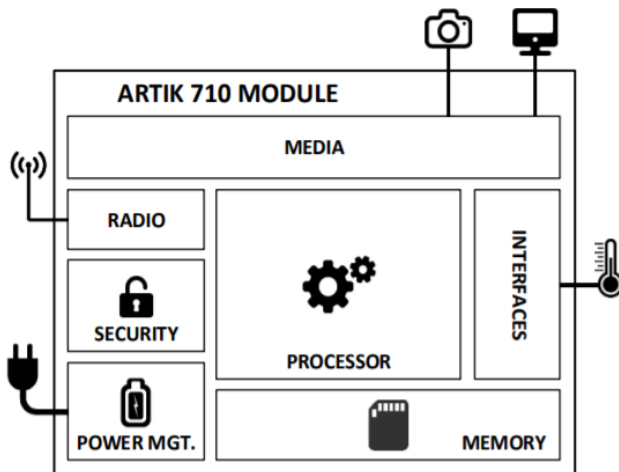

ARTIK 710 Module Block Diagram

Processor	
CPU	8x ARM® Cortex®-A53@1.4GHz
GPU	3D graphics accelerator
Media	
Camera I/F	4-Lane MIPI CSI
Display	4-Lane MIPI DSI up to FHD@24bpp
Audio	I ² S audio interface
Memory	
DRAM	1GB DDR3 @ 800MHz
FLASH	4GB eMMC
Security	
Secure Element	Secure point to point authentication and data transfer
Trusted Execution Environment	Trustware
Radio	
WLAN	IEEE 802.11a/b/g/n/ac
Bluetooth	4.1 (Classic+BLE)
802.15.4	ZigBee/Thread
Power Management	
PMIC	Provides all power of the ARTIK 710 Module using on board bucks and LDOs
Interfaces	
Analog and Digital I/O	GPIO, I ² C, SPI, UART, SDIO, USB 2.0, JTAG, Analog Input

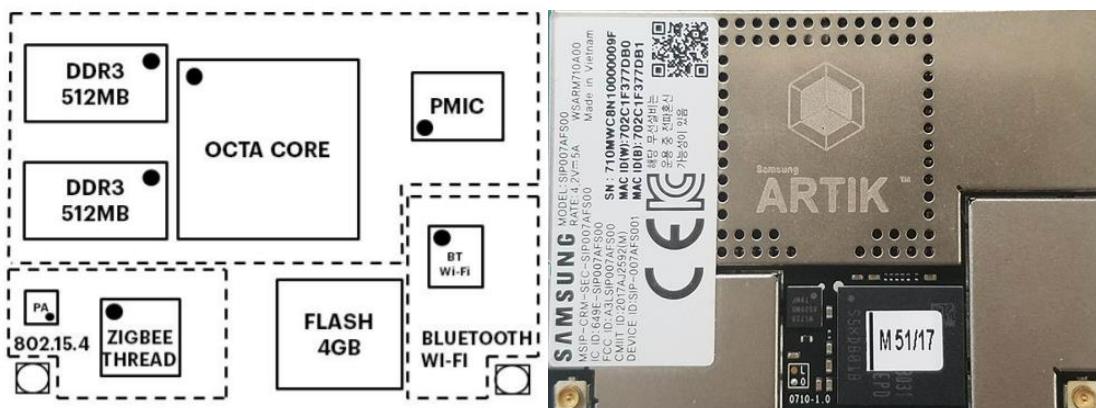
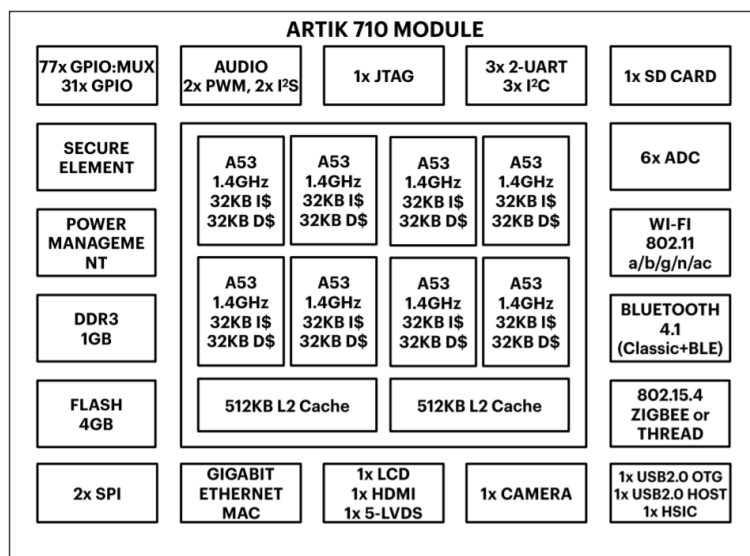

Please refer to www.artik.io website for more details on Samsung ARTIK 710 module.

.5.2 Accelerometers - Magnetometers Sensors

The LSM303AGR is an ultra-low-power high-performance system-in-package featuring a 3D digital linear acceleration sensor and a 3D digital magnetic sensor.

The LSM303AGR has linear acceleration full scales of $\pm 2g/\pm 4g/\pm 8g/\pm 16g$ and a magnetic field dynamic range of ± 50 gauss.

The LSM303AGR includes an I2C serial bus interface that supports standard, fast mode, fast mode plus, and high-speed (100 kHz, 400 kHz, 1 MHz, and 3.4 MHz) and an SPI serial standard interface.

The system can be configured to generate an interrupt signal for free-fall, motion detection and magnetic field detection.

The magnetic and accelerometer blocks can be enabled or put into power-down mode separately.

The LSM303AGR is available in a plastic land grid array package (LGA) and is guaranteed to operate over an extended temperature range from $-40\text{ }^{\circ}\text{C}$ to $+85\text{ }^{\circ}\text{C}$.

Features

- 3 magnetic field channels and 3 acceleration channels
- ± 50 gauss magnetic dynamic range
- Hard, soft ironing for external magnetic sensor corrections
- $\pm 2/\pm 4/\pm 8/\pm 16$ g selectable acceleration full scales
- 16-bit data output
- Analog supply voltage 1.71 V to 3.6 V
- Selectable power mode/resolution for accelerometer and magnetometer
- Single measurement mode for magnetometer
- Programmable interrupt generators for free-fall, motion detection and magnetic field detection
 - Embedded self-test
 - Embedded temperature sensor
 - Embedded FIFO
 - ECOPACK[®], RoHS and “Green” compliant

For any specific information and for the firmware commands and procedures, please refer to the data sheet of the components.

.5.3 Accelerometers - Gyroscopes Sensors

The LSM6DSL is a system-in-package featuring a 3D digital accelerometer and a 3D digital gyroscope performing at 0.65 mA in high-performance mode and enabling always-on low-power features for an optimal motion experience for the consumer.

The LSM6DSL supports main OS requirements, offering real, virtual and batch sensors with 4 kbyte for dynamic data batching.

ST's family of MEMS sensor modules leverages the robust and mature manufacturing processes already used for the production of micromachined accelerometers and gyroscopes.

The various sensing elements are manufactured using specialized micromachining processes, while the IC interfaces are developed using CMOS technology that allows the design of a dedicated circuit which is trimmed to better match the characteristics of the sensing element.

The LSM6DSL has a full-scale acceleration range of $\pm 2/\pm 4/\pm 8/\pm 16$ g and an angular rate range of $\pm 125/\pm 245/\pm 500/\pm 1000/\pm 2000$ dps.

High robustness to mechanical shock makes the LSM6DSL the preferred choice of system designers for the creation and manufacturing of reliable products.

The LSM6DSL is available in a plastic land grid array (LGA) package.

Features

- Power consumption: 0.4 mA in combo normal mode and 0.65 mA in combo high-performance mode
- “Always-on” experience with low power consumption for both accelerometer and gyroscope
- Smart FIFO up to 4 kbyte based on features set
- Android M compliant
- Hard, soft ironing for external magnetic sensor corrections
- $\pm 2/\pm 4/\pm 8/\pm 16$ g full scale
- $\pm 125/\pm 245/\pm 500/\pm 1000/\pm 2000$ dps full scale

- Analog supply voltage: 1.71 V to 3.6 V
- Independent IOs supply (1.62 V)
- Compact footprint, 2.5 mm x 3 mm x 0.83 mm
- SPI & I²C serial interface with main processor data synchronization feature
- Pedometer, step detector and step counter
- Significant motion and tilt function
- Standard interrupts: free-fall, wakeup, 6D/4D orientation, click and double-click
- Embedded temperature sensor
- ECOPACK[®], RoHS and “Green” compliant

For any specific information and for the firmware commands and procedures, please refer to the data sheet of the components.

.5.4 Barometer/Pressure sensor

The LPS22HB is an ultra-compact piezo resistive absolute pressure sensor which functions as a digital output barometer.

The device comprises a sensing element and an IC interface which communicates through I2C or SPI from the sensing element to the application.

The sensing element, which detects absolute pressure, consists of a suspended membrane manufactured using a dedicated process developed by ST.

The LPS22HB is available in a full-mold, holed LGA package (HLGA). It is guaranteed to operate over a temperature range extending from -40 °C to +85 °C. The package is holed to allow external pressure to reach the sensing element.

Features

- 260 to 1260 hPa absolute pressure range
- Current consumption down to 3 μA
- High overpressure capability: 20x full-scale
- Embedded temperature compensation
- 24-bit pressure data output • 16-bit temperature data output
- ODR from 1 Hz to 75 Hz
- SPI and I²C interfaces
- Embedded FIFO
- Interrupt functions: Data Ready, FIFO flags, pressure thresholds
- Supply voltage: 1.7 to 3.6 V
- High shock survivability: 22,000 g
- Small and thin package • ECOPACK[®] lead-free compliant

Block diagram

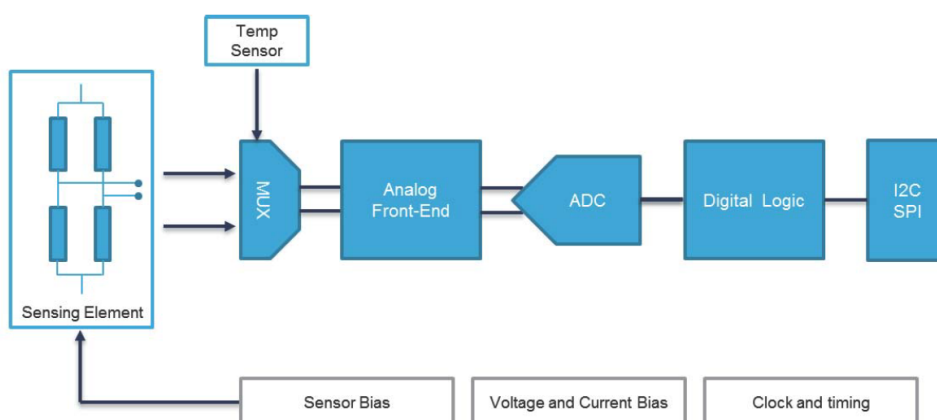

For any specific information and for the firmware commands and procedures, please refer to the data sheet of the components.

.5.5 Proximity sensor

The VL53L0X is a new generation Time-of-Flight (ToF) laser-ranging module housed in the smallest package on the market today, providing accurate distance measurement whatever the target reflectance unlike conventional technologies. It can measure absolute distances up to 2m, setting a new benchmark in ranging performance levels, opening the door to various new applications.

The VL53L0X integrates a leading-edge SPAD array (Single Photon Avalanche Diodes) and embeds ST's second generation FlightSense patented technology.

The VL53L0X's 940nm VCSEL emitter (Vertical Cavity Surface-Emitting Laser), is totally invisible to the human eye, coupled with internal physical infrared filters, it enables longer ranging distance, higher immunity to ambient light and better robustness to cover-glass optical cross-talk.

Features

- Fully integrated miniature module
 - 940nm Laser VCSEL
 - VCSEL driver
 - Ranging sensor with advanced embedded micro controller
 - 4.4 x 2.4 x 1.0mm
- Fast, accurate distance ranging
 - Measures absolute range up to 2m
 - Reported range is independent of the target reflectance
 - Operates in high infrared ambient light levels
 - Advanced embedded optical cross-talk compensation to simplify cover glass selection
- Eye safe
 - Class 1 laser device compliant with latest standard IEC 60825-1:2014 - 3rd edition
- Easy integration
 - Single reflowable component
 - No additional optics
 - Single power supply
 - I2C interface for device control and data transfer
 - Xshutdown (Reset) and interrupt GPIO
 - Programmable I2C address

Block Diagram

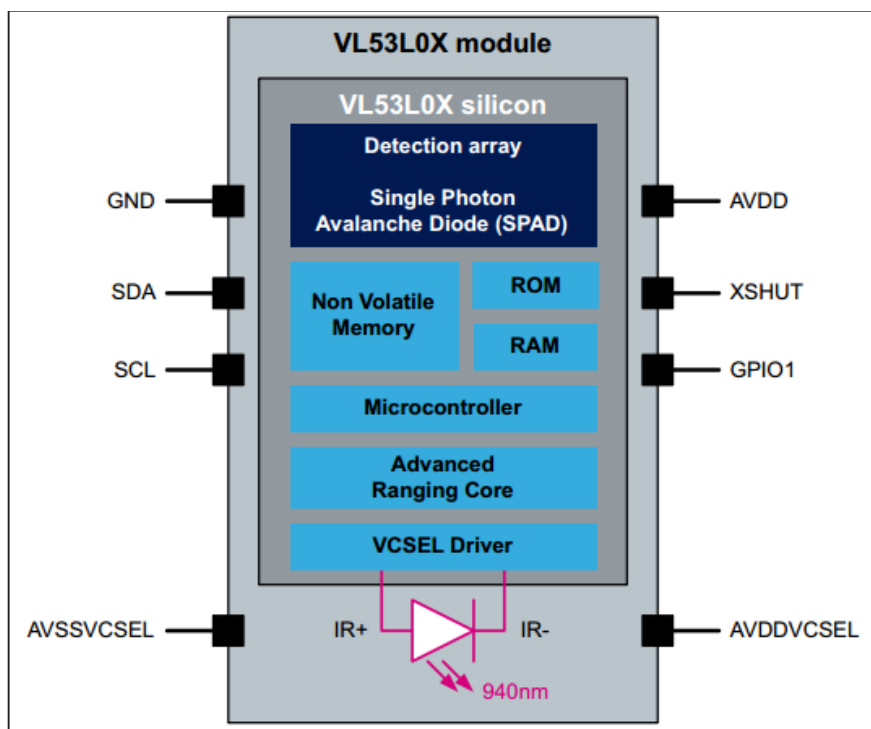

For any specific information and for the firmware commands and procedures, please refer to the data sheet of the components.

.5.6 ETHERNET

The KSZ9031RNX is a completely integrated triple speed (10Base-T/100Base-TX/1000Base-T) Ethernet Physical Layer Transceiver for transmission and reception of data over standard CAT-5 unshielded twisted pair (UTP) cable. The KSZ9031RNX reduces board cost and simplifies board layout by using on-chip termination resistors for the four differential pairs and by integrating a LDO controller to drive a low cost MOSFET to supply the 1.2V core. On the copper media interface, the KSZ9031RNX can automatically detect and correct for differential pair misplacements and polarity reversals, and correct propagation delays and re-sync timing between the four differential pairs, as specified in the IEEE 802.3 standard for 1000Base-T operation. The KSZ9031RNX provides the Reduced Gigabit Media Independent Interface (RGMII) for direct connection to RGMII MACs in Gigabit Ethernet Processors and Switches for data transfer at 10/100/1000 Mbps speed. The KSZ9031RNX Evaluation Board (KSZ9031RNX-EVAL) provides a comprehensive platform to evaluate the KSZ9031RNX features. All KSZ9031RNX configuration pins are accessible either by jumpers, test points or interface connectors.

For any specific information and for the firmware commands and procedures, please refer to the data sheet of the components.

IMPORTANT FUNCTIONAL NOTE:

In KITRA 710C board the KSZ9031RNX is used in 10/100 Mbps with RGMII interface.

.5.7 HDMI

The board has one HDMI 1.4a connector (Micro D-Type).

The following video formats are supported:

- 480p/480i @59.94Hz/60Hz, 576p/576i@50Hz
- 720p/720i @50Hz/59.94Hz/60Hz
- 1080p/1080i @50Hz/59.94Hz/60Hz

IMPORTANT NOTE:

Chassis of the micro HDMI connector have to be protected from the external ESD contact discharge .

.5.8 USB HOST 2.0

The board has one USB HOST 2.0.

.5.9 USB OTG

KITRA 710C has one USB OTG.

.5.10 USB to serial (UART) converter

The platform has an embedded USB to UART converter that is connected directly to the debug serial port of the ARTIK 710 module that is useful during the development.

See the chapter 10 for the development details and how this serial port can be used.

.5.11 SD CARD

The Platform board has one SD-CARD interface supporting SD3.0.

.6 BOARD CONNECTORS

MICROUSB-B (USB OTG)	J14	HDMI TYPE-D	J12
MICROUSB-B (USB DEBUG)	J10	ETHERNET RJ45	J13
MICRO SD CARD CONNECTOR	J3	12V POWER CONNECTOR	J11
EXPANSION CONNECTOR	J7	USB TYPE A (USB HOST)	J8

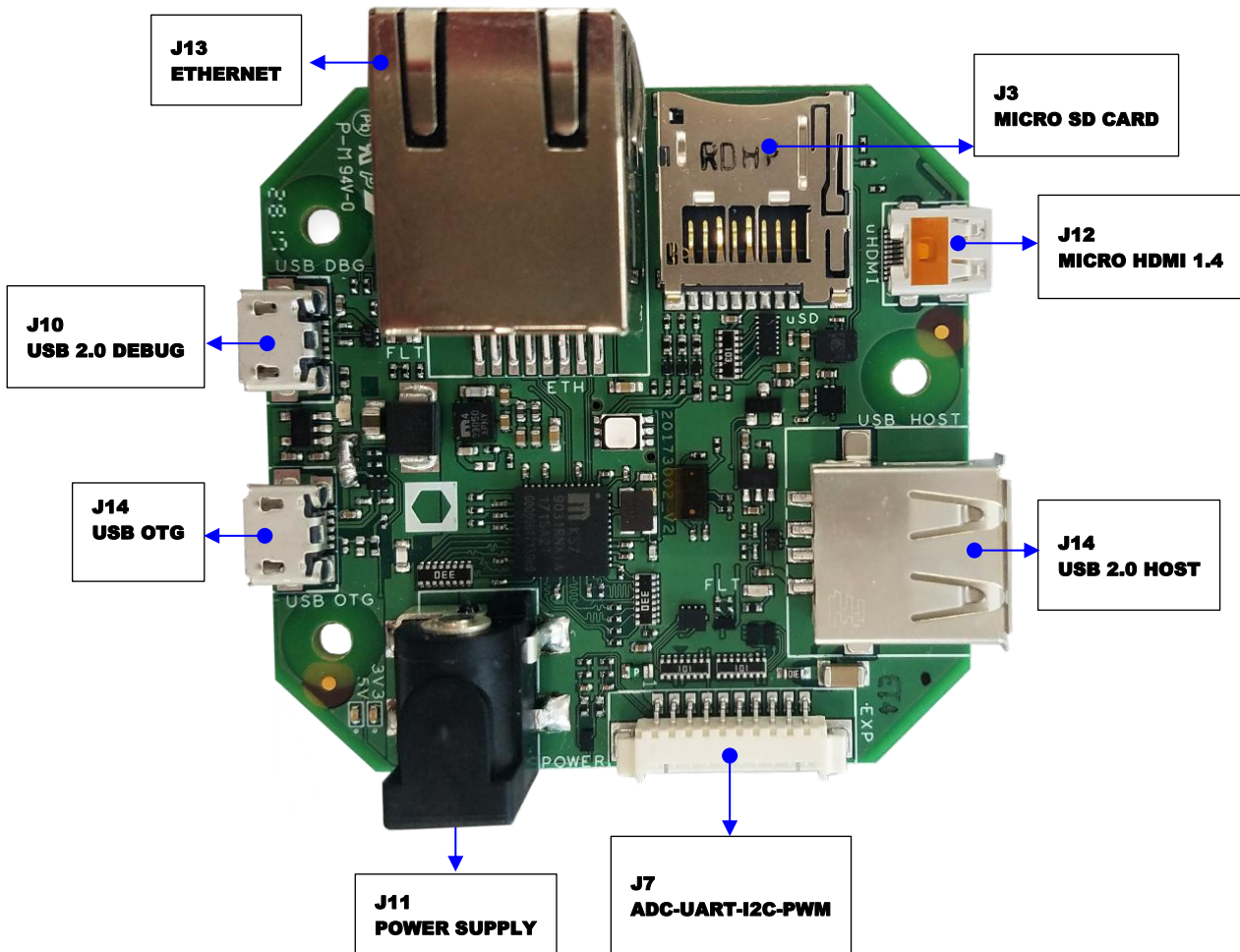

.6.1 POWER SUPPLY CONNECTOR

Input voltage type: DC

Typical input voltage: 12V

Power Input Max: 15W

Connector type mounted on KITRA 710C: Cui PJ-002AH-SMT-TR

Mate with: Power Jack DI 2.1mm DE 5.5mm (Example Cui PP3-002A)

.6.2 EXPANSIONS CONNECTOR

FUNCTIONAL NOTES ON EXPANSION CONNECTOR LINES

- Lines PWM0 and PWM1 have a couple of 100ohm internal resistor so maximum current per output is 15mA.
- Lines ADC_AIN1 and ADC_AIN2 have an internal voltage divider that scale down the external voltage to a factor equal to 0,56. Maximum voltage at the ARTIK ADC pin is 1,8V and then externally the maximum voltage is 3,3V.
- I2C1_SDA/I2C1_SCL have 2,49kohm internal pull up to 3,3V.

PIN NAME	KITRA 710C PIN CONNECTOR	ARTIK 710 PIN	SPECIFICATIONS
+3V3	J7-1		Voltage source that can be used to power external sensors. Maximum current 100mA, protected by a resettable fuse.
ADC_AIN1	J7-2	AP_ADC0	12 bit resolution. 3,3V absolute maximum range of analog voltage input. 780ohm series and 1kohm pull down.
ADC_AIN2	J7-3	AP_ADC1	12 bit resolution. 3,3V absolute maximum range of analog voltage input. 780ohm series and 1kohm pull down.
I2C2_SCL	J7-4	AP_GPD6_SCL	2,49kohm pull up to internal 3,3V.
I2C2_SDA	J7-5	AP_GPC7_SDA	2,49kohm pull up to internal 3,3V.
PWM1	J7-6	AP_GPC14_PWM2	3,3V voltage level of the digital output. 200ohm series resistor.
PWM0	J7-7	AP_GPD1_PWM0	3,3V voltage level of the digital output. 200ohm series resistor.
UART4_RX	J7-8	AP_UARTRX4	3,3V INPUT
UART4-TX	J7-9	AP_UARTTX4	3,3V OUTPUT
GND	J7-10		

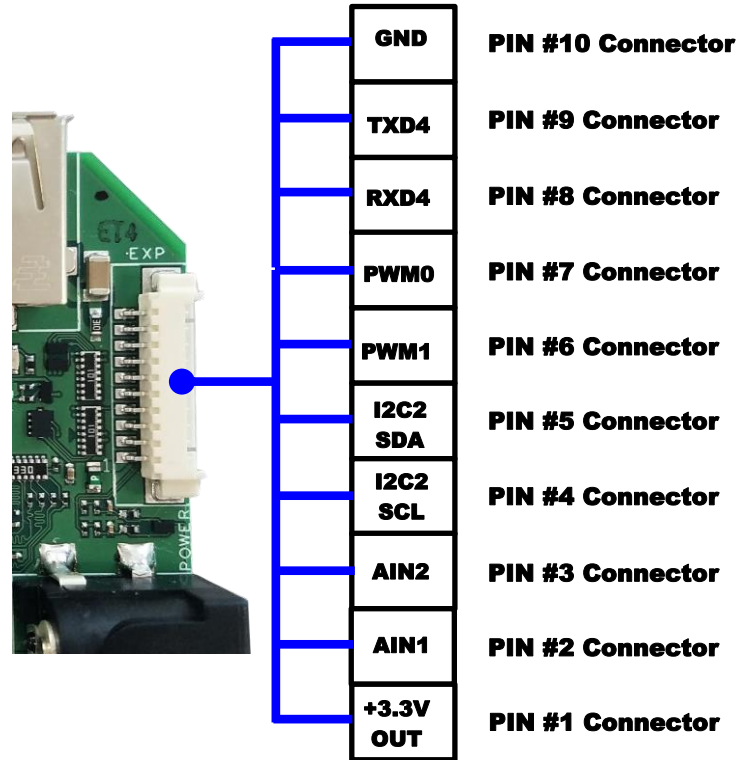

Connector type mounted on KITRA 710C: Molex Picoblade 53398-1071
Mate with: Molex Picoblade 51021-1000

.6.3 ANTENNA CONNECTORS

ARTIK 710 module embeds all the wireless functionalities related to Wi-Fi, Bluetooth, Zigbee and Thread and only external antenna must be attached. To do this the module has a couple of uFL connectors as indicated in the picture below.



Two antennas are required to use the full set of radio communication links on the ARTIK 710 Module. One supports the combination of Wi-Fi and BT, and the other is dedicated to 802.15.4 for ZigBee or Thread.

Caution: Do not apply power (enable) the radio chips before connecting antennas or damage to the chip may result.

The U.FL-R-SMT Hirose connector is used for both the BT/Wi-Fi and the 802.15.4 for ZigBee or Thread antenna connectors on the ARTIK 710 Module.

The mechanical size of the connector (receptacle) is described here in after, for suggestions on mating plug and more details on the connector, please contact Hirose Electric Co., LTD.

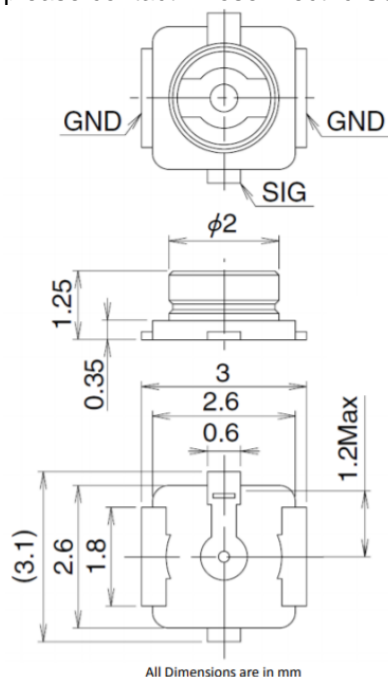

Figure 7. RF Connector for BT/Wi-Fi and ZigBee/Thread

.7 LEDS

KITRA 710C provides one RGB LED connected to 3 output lines connected directly to ARTIK 710 that can be managed by application software.



The board embeds also a couple of green LED useful for diagnostic that are directly connected to the power supplies output (5V and 3,3V).



.8 BUTTON

RESET KEY	PB3-PB4
-----------	---------



By pressing for about one second and RESET can be used to reboot the system. KITRA 710C will boot as soon as the power input is applied and the startup phase will be indicated by the RGB LED that turn on in RED color and then in GREEN.

.9 BOOTING SEQUENCE

This section describes the various boot modes that are supported on the KITRA 710C board. Next table and figure show how to manipulate dipswitch located on the board to set the various booting options that are available.

Dipswitch position	eMMC 1st Boot	SD Card 1st Boot	USB 1st Boot
1	OFF	OFF	ON
2	OFF	OFF	ON
3	X	X	X
4	OFF	ON	X



When 'eMMC 1st Boot' is selected as a booting option, the system will first try to boot from eMMC, if this fails the system will search for an SD Card to boot from. If booting from the SD-Card also fails the system tries to boot from USB. When choosing the SD-Card booting option, the system starts with booting from SD, and if this fails will continue to try a USB boot. When USB is selected as the booting mechanism of choice, only a USB boot will be attempted.

.10 KITRA 710C DEVELOPMENT BOARD BOOTING

This section will describe how to start working with your KITRA 710C Development Environment by setting up a serial connection on your development PC and booting up the ARTIK 710 Development Environment.

SERIAL PORT CONNECTION

As a first step we will select a serial console to communicate with the ARTIK 710 Module that is located on the ARTIK 710 Development Environment.

You can use a typical Linux® serial console as depicted in the next Figure, using the USB 2.0 DEBUG connector.

To use the serial USB cable you need to install the associated device driver..

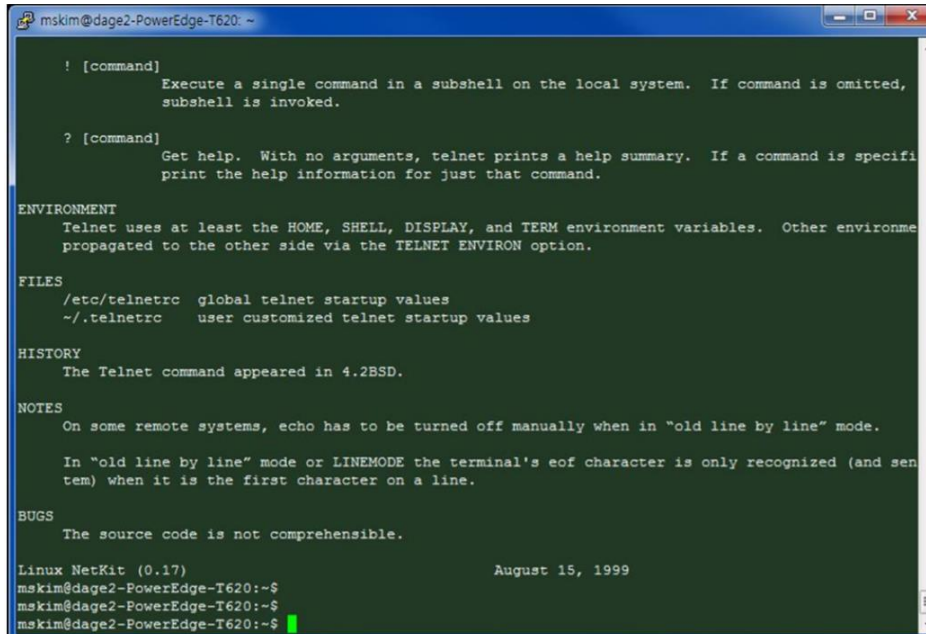

```

mskim@dage2-PowerEdge-T620: ~
! [command]
    Execute a single command in a subshell on the local system.  If command is omitted,
    subshell is invoked.

? [command]
    Get help.  With no arguments, telnet prints a help summary.  If a command is specifi
    print the help information for just that command.

ENVIRONMENT
    Telnet uses at least the HOME, SHELL, DISPLAY, and TERM environment variables.  Other environme
    propagated to the other side via the TELNET ENVIRON option.

FILES
    /etc/telnetrc  global telnet startup values
    ~/.telnetrc   user customized telnet startup values

HISTORY
    The Telnet command appeared in 4.2BSD.

NOTES
    On some remote systems, echo has to be turned off manually when in "old line by line" mode.

    In "old line by line" mode or LINEMODE the terminal's eof character is only recognized (and sen
    tem) when it is the first character on a line.

BUGS
    The source code is not comprehensible.

Linux NetKit (0.17)                                August 15, 1999
mskim@dage2-PowerEdge-T620:~$
mskim@dage2-PowerEdge-T620:~$
mskim@dage2-PowerEdge-T620:~$
  
```

Setting up a connection with the ARTIK 710 Module can be done in a wired or wireless manner. Here we choose to install PuTTY a free serial console.

The software can be downloaded from [HTTP://WWW.PUTTY.ORG/](http://www.putty.org/).

Once downloaded go through the following steps:

- 1) Open the device manager on the control panel.
- 2) When using a PC install the USB to Serial driver. The driver can be found at the following location: (http://www.ftdichip.com/Drivers/CDM/CDM21218_Setup.zip). For other drivers please visit (<http://www.ftdichip.com/Drivers/D2XX.htm>).
- 3) Check the COM port number on your PC when you connect the USB serial cable. In our case the COM port allocated is COM9.



- 4) Set the PuTTY configuration as follows:
 - a) Set the "Serial line" as the COM port number found in step 3.
 - b) Set the COM speed to "115200".
 - c) Set the connection type to "Serial".
 - d) Save the session under ARTIK7.
- 5) Select your saved session and click the "Open" button.

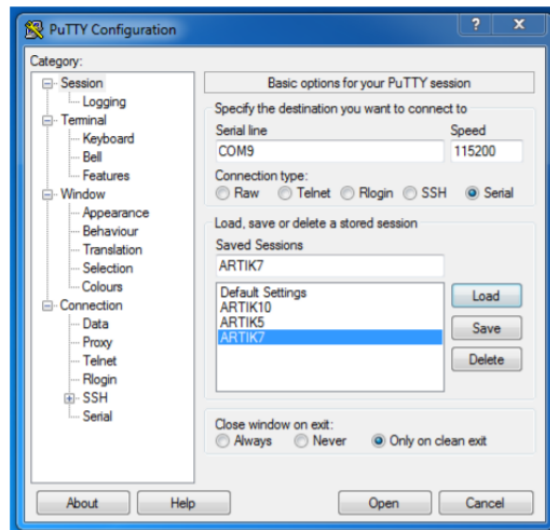

POWER ON THE KITRA 710C

To power up the KITRA 710C you first have to connect the power adapter and the Platform Board as shown following the requirements indicated in chapter 6.1.

Once the jack connector is applied and the board is powered, KITRA 710C will automatically start the booting process and you should see the messages from your console, using the serial connection that you previously established.

.11 RF ELECTRICAL SPECIFICATIONS

All performance numbers related to 802.11 for Wi-Fi, Bluetooth, and 802.15.4 for Zigbee mentioned in this section are preliminary and likely to change once module characterization has taken place. All these data come from the Samsung ARTIK 710 data sheet because the RF functions are integrated in the module, for more info visit www.artik.io.

Wi-Fi, 2.4GHz Receiver RF Specifications

Parameter	Conditions	Min	Typ	Max	Unit
Frequency Range	-	2400	-	2500	MHz
Minimum receiver sensitivity in 802.11b mode (2.4GHz)					
1Mbps	PER < 8%,	-	-	-92	dBm
2Mbps	Packet size = 1024 bytes	-	-	-80	dBm
5.5Mbps		-	-	-76	dBm
11Mbps		-	-	-83	dBm
Minimum receiver sensitivity in 802.11g mode (2.4GHz)					
6Mbps	PER < 10%,	-	-	-82	dBm
9Mbps	Packet size= 1024 bytes	-	-	-81	dBm
12Mbps		-	-	-79	dBm
18Mbps		-	-	-77	dBm
24Mbps		-	-	-74	dBm
36Mbps		-	-	-70	dBm
48Mbps		-	-	-66	dBm
54Mbps		-	-	-65	dBm
Minimum receiver sensitivity in 802.11n mode (2.4GHz)					
MCS 0	PER<10%,	-	-	-82	dBm
MCS 1	Packet size= 4096 bytes, GF, 800ns GI, Non-STBC	-	-	-79	dBm
MCS 2		-	-	-77	dBm
MCS 3		-	-	-74	dBm
MCS 4		-	-	-70	dBm
MCS 5		-	-	-68	dBm
MCS 6		-	-	-65	dBm
MCS 7		-	-	-64	dBm

Wi-Fi, 2.4GHz Transmitter RF Specifications

Parameter	Conditions	Min	Typ	Max	Unit
Linear output power					
Maximum output power in 802.11b mode	As specified in IEEE802.11	-	16	-	dBm
Maximum output power in 802.11g mode		-	12.5	-	dBm
Maximum output power in 802.11n mode		-	13	-	dBm
Transmit spectrum mask					
Margin to 802.11b spectrum mask	Maximum output power	0	-	-	dBr
Margin to 802.11g spectrum mask		0	-	-	dBr
Margin to 802.11n spectrum mask		0	-	-	dBr
Transmit modulation accuracy in 802.11b mode					
1Mbps	As specified in IEEE 802.11b	-	-	35	%
2Mbps		-	-	35	%
5.5Mbps		-	-	35	%
11Mbps		-	-	35	%
Transmit modulation accuracy in 802.11g mode					
6Mbps	As specified in IEEE 802.11g	-	-	-5	dB
9Mbps		-	-	-8	dB
12Mbps		-	-	-10	dB
18Mbps		-	-	-13	dB
24Mbps		-	-	-16	dB
36Mbps		-	-	-19	dB
48Mbps		-	-	-22	dB
54Mbps		-	-	-25	dB
Transmit modulation accuracy in 802.11n mode					
MCS7	As specified in IEEE 802.11n	-	-	-27	dB
Transmit power-on and power-down ramp time in 802.11b mode					
Transmit power-on ramp time from 10% to 90% output power	-	-	-	2	μs
Transmit power-down ramp time from 90% to 10% output power	-	-	-	2	μs

Wi-Fi, 5GHz Receiver RF Specifications

Parameter	Conditions	Min	Typ	Max	Unit
Frequency Range	-	4900	-	5845	MHz
Minimum receiver sensitivity in 802.11a mode					
6Mbps	PER < 10%	-	-	-82	dBm
12Mbps		-	-	-79	dBm
24Mbps		-	-	-74	dBm
36Mbps		-	-	-70	dBm
48Mbps		-	-	-66	dBm
54Mbps		-	-	-65	dBm
Minimum receiver sensitivity in 802.11n (HT-20) mode					
MCS 0	-	-	-	-82	dBm
MCS 1		-	-	-79	dBm
MCS 2		-	-	-77	dBm
MCS 3		-	-	-74	dBm
MCS 4		-	-	-70	dBm
MCS 5		-	-	-66	dBm
MCS 6		-	-	-65	dBm
MCS 7		-	-	-64	dBm
Minimum receiver sensitivity in 802.11n (HT-40) mode					
MCS 0	PER<10%	-	-	-79	dBm
MCS 1		-	-	-76	dBm
MCS 2		-	-	-74	dBm
MCS 3		-	-	-71	dBm
MCS 4		-	-	-67	dBm
MCS 5		-	-	-63	dBm
MCS 6		-	-	-62	dBm
MCS 7		-	-	-61	dBm
Minimum receiver sensitivity in 802.11ac (VHT-20) mode					
MCS 0	PER<10%	-	-	-82	dBm
MCS 1		-	-	-79	dBm
MCS 2		-	-	-77	dBm
MCS 3		-	-	-74	dBm
MCS 4		-	-	-70	dBm
MCS 5		-	-	-66	dBm
MCS 6		-	-	-65	dBm
MCS 7		-	-	-64	dBm
MCS 8		-	-	-59	dBm
Minimum receiver sensitivity in 802.11ac (VHT-40) mode					

Parameter	Conditions	Min	Typ	Max	Unit
MCS 0	PER<10%	-	-	-79	dBm
MCS 1		-	-	-76	dBm
MCS 2		-	-	-74	dBm
MCS 3		-	-	-71	dBm
MCS 4		-	-	-67	dBm
MCS 5		-	-	-63	dBm
MCS 6		-	-	-62	dBm
MCS 7		-	-	-61	dBm
MCS 8		-	-	-56	dBm
MCS 9		-	-	-54	dBm
Minimum receiver sensitivity in 802.11ac (VHT-80) mode					
MCS 0	PER<10%	-	-	-76	dBm
MCS 1		-	-	-73	dBm
MCS 2		-	-	-71	dBm
MCS 3		-	-	-68	dBm
MCS 4		-	-	-64	dBm
MCS 5		-	-	-60	dBm
MCS 6		-	-	-59	dBm
MCS 7		-	-	-58	dBm
MCS 8		-	-	-53	dBm
MCS 9		-	-	-51	dBm
Maximum input level					
Maximum input signal level in 802.11a mode	PER < 10%	-30	-	-	dBm
Maximum input signal level in 802.11n mode	PER < 10%	-30	-	-	dBm
Maximum input signal level in 802.11ac mode	PER < 10%	-30	-	-	dBm

Wi-Fi, 5GHz Transmitter RF Specifications

Parameter	Conditions	Min	Typ	Max	Unit
Frequency Range	-	4900		5845	MHz
Linear output power					
Maximum output power in 802.11a mode	54M, UNII-2e	-	12.5	-	dBm
Maximum output power in 802.11n mode	HT20, MCS7, UNII-2e	-	12	-	dBm
	HT40, MCS7, UNII-2e	-	11	-	dBm
Maximum output power in 802.11ac mode	VHT20, MCS8, UNII-2e	-	12	-	dBm
	VHT40, MCS9, UNII-2e	-	11	-	dBm
	VHT80, MCS9, UNII-2e	-	8	-	dBm
Transmit spectrum mask					
Margin to 802.11a spectrum mask	Maximum output power	0	-	-	dBr
Margin to 802.11n spectrum mask		0	-	-	dBr
Margin to 802.11ac spectrum mask		0	-	-	dBr
Transmit constellation error in 802.11a mode					
54Mbps	As specified in IEEE 802.11n	-	-	-25	dB
Transmit constellation error in 802.11n (HT-20, HT-40) mode					
MCS 7	As specified in IEEE 802.11n	-	-	-27	dB
Transmit constellation error in 802.11ac (VHT-20) mode					
MCS 8	As specified in IEEE 802.11n	-	-	-30	dB
Transmit constellation error in 802.11ac (VHT-40, VHT-80) mode					
MCS 9	As specified in IEEE 802.11n	-	-	-32	dB

Bluetooth RF Specifications

. Bluetooth Receiver RF Specifications

Parameter	Conditions	Min	Typ	Max	Unit
Frequency Range	-	2402	-	2480	MHz
Sensitivity (BER)	GPSK, BER \leq 0.1%	-	-	-80	dBm
	$\pi/4$ -DQPSK, BER \leq 0.1%	-	-	-80	dBm
	BER \leq 0.1%, 8DPSK	-	-	-80	dBm
Maximum Input Level	GPSK, BER \leq 0.1%	-20	-	-	dBm
	$\pi/4$ -DQPSK, BER \leq 0.1%	-20	-	-	dBm
	BER \leq 0.1%, 8 DPSK	-20	-	-	dBm
BDR					
Intermodulation Performance	-	-	-	0.1	%
Rx C/I Performance	1DH1	-	-	0.1	%
	1DH3	-	-	0.1	%
	1DH5	-	-	0.1	%
EDR					
Rx C/I Performance	2DH1	-	-	0.1	%
	2DH3	-	-	0.1	%
	2DH5	-	-	0.1	%
	3DH1	-	-	0.1	%
	3DH3	-	-	0.1	%
	3DH5	-	-	0.1	%
Rx BER Floor Performance	BER \leq 0.001%	-	-	-70	dBm

Bluetooth Transmitter RF Specifications

Parameter	Conditions	Min	Typ	Max	Unit
Frequency Range	-	2402	-	2480	MHz
Output Power (Average)					
BDR (QPSK)	2440 MHz	-	7	-	dBm
EDR ($\pi/4$ -DQPSK)	2440 MHz	-	3	-	dBm
EDR (8DPSK)	2440 MHz	-	3	-	dBm

Bluetooth Low Energy (BLE) RF Specifications

Parameter	Conditions	Min	Typ	Max	Unit
Frequency Range	-	2402	-	2480	MHz
Rx Receiver Sensitivity PER	At -70dBm	-	-	30.8	%
Rx C/I and Receiver Selectivity Performance PER	-	-	-	30.8	%
Tx Power	-	-	7	-	dBm

802.15.4 Receiver RF Specifications

The typical numbers indicated in next tables are one standard deviation below the mean, measured at room temperature 25°C. The Min and Max numbers were measured over process corners at room temperature

802.15.4 Receiver RF Specifications

Parameter	Test Condition	Min	Typ	Max	Unit
Operating Frequency Range	-	2400	-	2483.5	MHz
Receiver Sensitivity PER	At -95dBm	-	-	1	%
Receiver Sensitivity Search	At PER 1%	-	-	-95	dBm
Receiver Interference Rejection PER	At -2 Channel, Alternate Channel, 30dB	-	-	1	%
Receiver Interference Rejection PER	At -1 Channel, Adjacent Channel, 0dB	-	-	1	%
Receiver Interference Rejection PER	At +1 Channel, Adjacent Channel, 0dB	-	-	1	%
Receiver Interference Rejection PER	At +2 Channel, Alternate Channel, 30dB	-	-	1	%
Error Vector Magnitude - RMS (EVM)	At Target Power	-	-	30	%
Error Vector Magnitude - Offset (EVM)	At Target Power	-	-	10	%
Receiver Maximum Input Level of Desired Signal	At -20dBm Input	-	-	1	%

802.15.4 Transmitter RF Specifications

Parameter	Test Condition	Min	Typ	Max	Unit
Maximum output power	At highest normal mode power setting	-	6.5	-	dBm
Minimum output power	At lowest power setting	-	-55	-	dBm
Error vector magnitude (Offset-EVM)	As defined by IEEE 802.15.4-2003, which sets a 35% maximum	-	-	10	%
Carrier frequency error	-	-40	-	+40	ppm
PSD mask relative	3.5 MHz away (Normal)	-20	-	-	dBm
PSD mask absolute	100 KHz BW	-30	-	-	dBm

.12 SPECIFICATIONS

Parameter	Minimum	Typical	Maximum	Conditions
External power supply	6V	12V	14V	Standard 5.5mm jack
Power rating			15W	
Operation temperature	0	-	40°C	Without heatsink
Operation temperature	0	-	70°C	With heatsink or cooling
Storage temperature	-25	-	70°C	Electronics board

Wireless standard	Standard	Transmitted power
Bluetooth		7 dBm
Wi-Fi 2,4GHz	802.11b mode	16 dBm
Wi-Fi 2,4GHz	802.11g mode	12,5 dBm
Wi-Fi 2,4GHz	802.11n mode	13 dBm
Wi-Fi 5GHz	802.11a mode	12,5 dBm
Wi-Fi 5GHz	802.11n mode	12 dBm
Wi-Fi 5GHz	802.11ac mode	12 dBm
Zigbee	802.15.4	6,5 dBm

.13 MECHANICAL SPECIFICATIONS

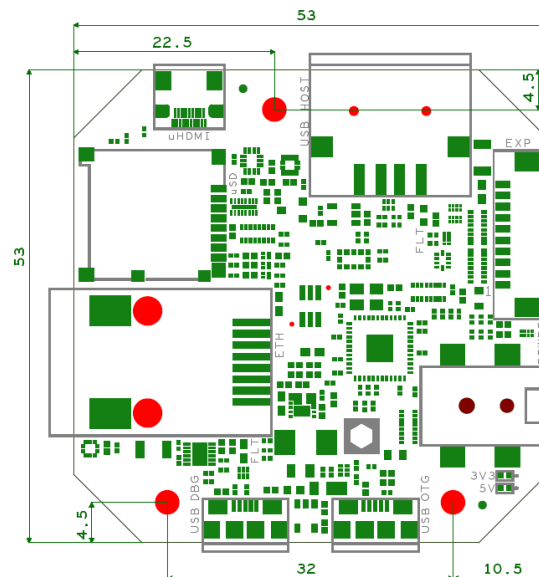

The measures are in mm and the view is TOP side.

.14 HOUSING PRESCRIPTION

KITRA 710C is PCBA (Printed Circuit Board Assembly) system and so it is not a final product, it's necessary to close the board in a specific housing or mechanical box.

The housing, in addition to achieve the desired functionality, must be fireproof (in case of unexpected failure of the electronic board component that produce a little spark, a fire will be blocked).

.15 PACKAGING (STARTER KIT)

Standard package of the KITRA 710C bundle kit is made up with the next items:

- KITRA 710C electronics board;
- 2.4GHz uFL antennas.



.16 EU REGULATORY DISCLOSURES

STATEMENT

Hereby, RushUp s.r.l. declares that this IoT product is in compliance with Directive 2014/53/EU.

The full text of the EU declaration of conformity is available at the following internet address:

- <https://www.rushup.tech/kitra710C/>

The 5150 - 5350 MHz and 5470 - 5725 MHz bands are for indoor use only, the use of the KITRA 710C with Wi-Fi wireless communications is restricted to indoor use only.

.17 OPERATING ENVIRONMENT

The operating environment excludes special environments (extreme temperatures, dust, humidity, vibrations, flammable gases, corrosive or explosive atmosphere, etc.).

.18 DISCLAIMERS

RushUp s.r.l. reserves the right to change products, information and specifications without notice.

Products and specifications discussed herein are for reference purposes only. All information discussed herein is provided on an "AS IS" basis, without warranties of any kind. This document and all information discussed herein remain the sole and exclusive property of RushUp. No license of any patent, copyright, mask work, trademark or any other intellectual property right is granted by one party to the other party under this document, by implication, estoppel or other-wise.

RushUp products are not intended for use in life support, critical care, medical, safety equipment, or similar applications where product failure could result in loss of life or personal or physical harm, or any military or defense application, or any governmental procurement to which special terms or provisions may apply. For updates or additional information about RushUp products, contact RushUp office. All brand names, trademarks and registered trademarks belong to their respective owners.

RushUp and KITRA are trademarks of RushUp srl.

X-ON Electronics

Largest Supplier of Electrical and Electronic Components

Click to view similar products for [Single Board Computers](#) category:

Click to view products by [RushUp](#) manufacturer:

Other Similar products are found below :

[MANO882VPGGA-H81](#) [SSD3200W-S-SLC-INN 20-101-0738](#) [MVME61006E-2173R](#) [SHB230DGGA-RC](#) [IMB210VGGA](#) [IB915F-3955](#)
[MI958F-16C](#) [S2600WFT](#) [S2600STB](#) [BBS2600BPS](#) [BLKNUC7I3DNHNC1978015](#) [DEV-17745](#) [BEAGLEBOARD POCKET](#) [BPI-M5](#)
[MICROSOM I2 + WIFI/BT](#) [HUMMINGBOARD-I2EX BASE + WIFI/BT](#) [HUMMINGBOARD-I4 PRO + WIFI/BT](#) [VAB-600-B](#) [RT5350F-](#)
[OLINUXINO-EVB](#) [MITX-440-DVI-2E](#) [ATCA-7365-D-24GB](#) [NITX-315-DEVKIT](#) [A13-SOM-512](#) [NITX-315](#) [BANANA PI BPI-M1+](#) [A13-](#)
[SOM-WIFI-4GB](#) [AM3359-SOM-EVB-IND](#) [UPS-APLC2-A10-0432](#) [DFR0419](#) [UPS-APLP4-A10-0864](#) [UPS-APLP4-A10-0432](#) [UPS-APLP4-](#)
[A10-08128](#) [MI977F-Q27](#) [BBBLUE](#) [IB811F-I30](#) [DFR0470-ENT](#) [Nit6Q_i](#) [M2M \(TELIT\)](#) [RELAY PROFESSIONAL](#) [GCS22.2.080.2.2.I](#)
[GCS22.8.100.4.2.I](#) [GLS11.2.053.2.2.E](#) [A20-OLINUXINO-LIME-E16GS16M](#) [A20-OLINUXINO-LIME-S16M](#) [A20-OLINUXINO-LIME2-](#)
[E16GS16M](#) [A20-OLINUXINO-MICRO-E16GS16M](#) [A20-OLINUXINO-MICRO-S16M](#) [BANANA PI BPI-W2](#)