

30V High Side Over Voltage Protector

Features

- 30V standoff voltage
- Fixed 6.0V protection voltage
- Integrated OTP
- Environment Temperature: -40°C~85°C
- Maximum load Current 2A
- Typical equivalent on-resistance 110mΩ
- Input OVP with 0.1us reaction time
- SOT-23-3, SOT23-6 package

Applications

- All electronic devices with input DC power plug
- E-Cigarette
- Car Camera
- Cellphone

General Description

RY2334 is a high voltage 30V over voltage protector (OVP) which has a low on resistance, by only change the external connecting. It can be used as an OVP device or a high voltage switch. RY2334 consists of a charge pump, a configurable power MOSFET, a voltage reference, a gate driver and some logics and protection modules. RY2334 can react to an input surge very fast and shut off the switch in less than 0.1us. RY2334 is available in SOT-23-3, SOT23-6 package.

Typical Application Circuit

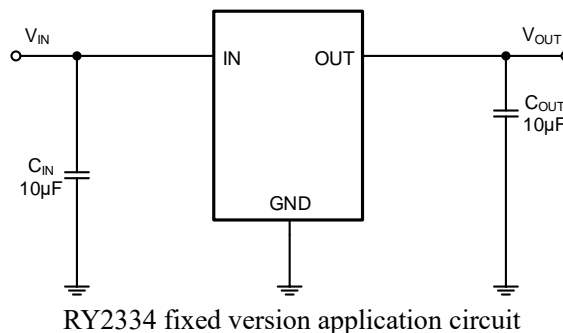

30V High Side Over Voltage Protector

Pin Description

Pin Configuration

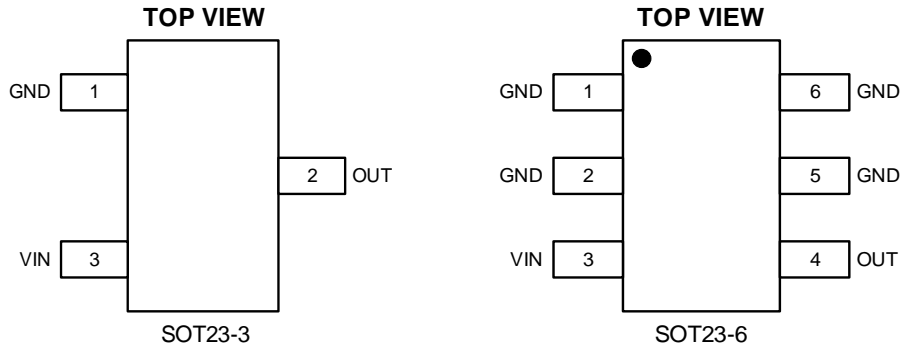

RY2334AT3 Top Marking: mAYLL [device code: mA, Y=year code, LL= lot number code)

RY2334AT6 Top Marking: mBYLL [device code: mB, Y=year code, LL= lot number code)

Pin Description

SOT23-3 Pin No.	SOT23-6 Pin No.	Name	Function
2	4	OUT	Output voltage (V_{OUT}) pin for the regulator
3	3	VIN	Input voltage (V_{IN}) pin for the regulator.
1	1/2/5/6	GND	Ground pin

Order Information ⁽¹⁾

Marking	Part No.	Model	Description	Package	T/R Qty
mAYLL	70702302	RY2334AT3	RY2334AT3 OVP IC, VIN 2.5-30V, OVP fixed 6.0V, 2A, SOT23-3	SOT23-3	3000PCS
mBYLL	70702301	RY2334AT6	RY2334AT6 OVP IC, VIN 2.5-30V, OVP fixed 6.0V, 2A, SOT23-6	SOT23-6	3000PCS

Note (1): All RYCHIP parts are Pb-Free and adhere to the RoHS directive.

30V High Side Over Voltage Protector

Specifications

Absolute Maximum Ratings ⁽¹⁾ ⁽²⁾

Item	Min	Max	Unit
Maximum V _{IN} voltage	-0.3	30	V
Power dissipation ⁽³⁾	Internally Limited		
Operating junction temperature, T _{J(MAX)}		150	°C
Storage temperature, T _{stg}	-65	150	°C
Lead Temperature (Soldering, 10sec.)		260	°C

Note (1): Exceeding these ratings may damage the device.

Note (2): The device is not guaranteed to function outside of its operating conditions.

Note (3): The maximum allowable power dissipation is a function of the maximum junction temperature, T_{J(MAX)}, the junction-to-ambient thermal resistance, R_{θJA}, and the ambient temperature, T_A. The maximum allowable power dissipation at any ambient temperature is calculated using: P_{D(MAX)} = (T_{J(MAX)} - T_A)/R_{θJA}. Exceeding the maximum allowable power dissipation causes excessive die temperature, and the regulator goes into thermal shutdown. Internal thermal shutdown circuitry protects the device from permanent damage. Thermal shutdown engages at T_J=160°C (typical) and disengages at T_J= 130°C (typical).

ESD Ratings

Item	Description	Value	Unit
V _(ESD-HBM)	Human Body Model (HBM) ANSI/ESDA/JEDEC JS-001-2014 Classification, Class: 2	±2000	V
V _(ESD-CDM)	Charged Device Mode (CDM) ANSI/ESDA/JEDEC JS-002-2014 Classification, Class: C0b	±200	V
I _{LATCH-UP}	JEDEC STANDARD NO.78E APRIL 2016 Temperature Classification, Class: I	±150	mA

Recommended Operating Conditions

Item	Min	Max	Unit
Operating junction temperature ⁽¹⁾	-40	125	°C
Operating temperature range	-40	85	°C
Input voltage V _{IN}	2.5	6	V

Note (1): All limits specified at room temperature (T_A = 25°C) unless otherwise specified. All room temperature limits are 100% production tested. All limits at temperature extremes are ensured through correlation using standard Statistical Quality Control (SQC) methods. All limits are used to calculate Average Outgoing Quality Level (AOQL).

30V High Side Over Voltage Protector

Thermal Information

Item	Description	SOT23 3 Pin	SOT23 6 Pin	Unit
R _{θJA}	Junction-to-ambient thermal resistance ⁽¹⁾⁽²⁾	208	180	°C/W
R _{θJC(top)}	Junction-to-case (top) thermal resistance	112	130	°C/W
R _{θJB}	Junction-to-board thermal resistance	56	45	°C/W
ψ _{JT}	Junction-to-top characterization parameter	9.2	35	°C/W
ψ _{JB}	Junction-to-board characterization parameter	52	45	°C/W
R _{θJC(bot)}	Junction-to-case (bottom) thermal resistance	N/A	N/A	°C/W

Note (1): The package thermal impedance is calculated in accordance to JESD 51-7.

Note (2): Thermal Resistances were simulated on a 4-layer, JEDEC board

Electrical Characteristics

V_{IN} =5V, T_A=25°C, unless otherwise noted.

Parameter	Test Conditions	Min	Typ.	Max	Units
Input Voltage		2.5		5.9	V
UVLO	Hys=260mV		2.4		V
OVP			6.0		V
OVP Range		2.5		30	V
R _{on}	VCC=5V, I _{out} =1A	-	110		mΩ
I _q	Standby current, I _N and V _{cc} < OVP voltage		150		uA
I _{sd}	Shutdown current		10		μA
Thermal Shutdown	Rising, Hys=50°C		135		°C

30V High Side Over Voltage Protector

Block Diagram

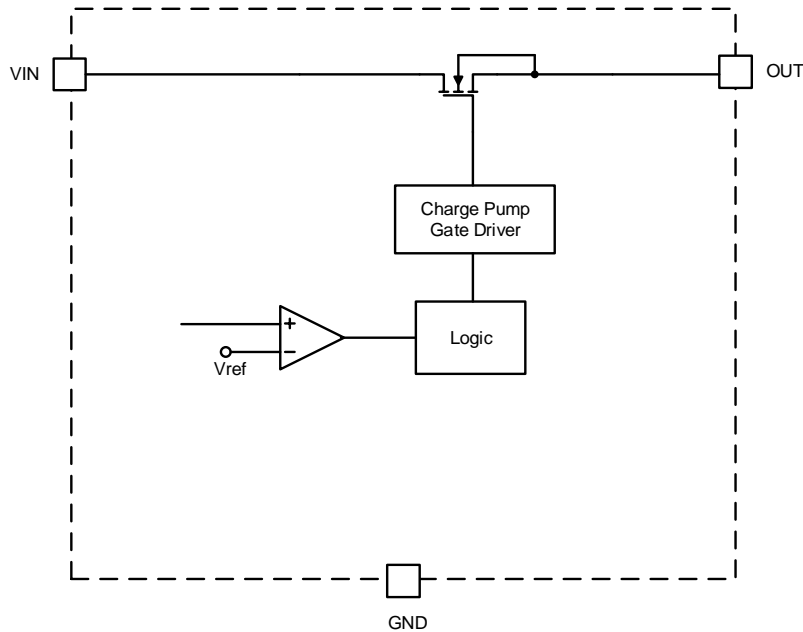

RY2334 Block Diagram

Detailed Description

RY2334 can disconnect the systems from its output pin (OUT) in case wrong input operating conditions are detected. The system is positive overvoltage protected up to 30V. The internal OVLO is 6.0V. RY2334 also has internal over temperature protect (OTP) function and it can monitor chip temperature to protect the device.

30V High Side Over Voltage Protector

Package Description

SOT23-3

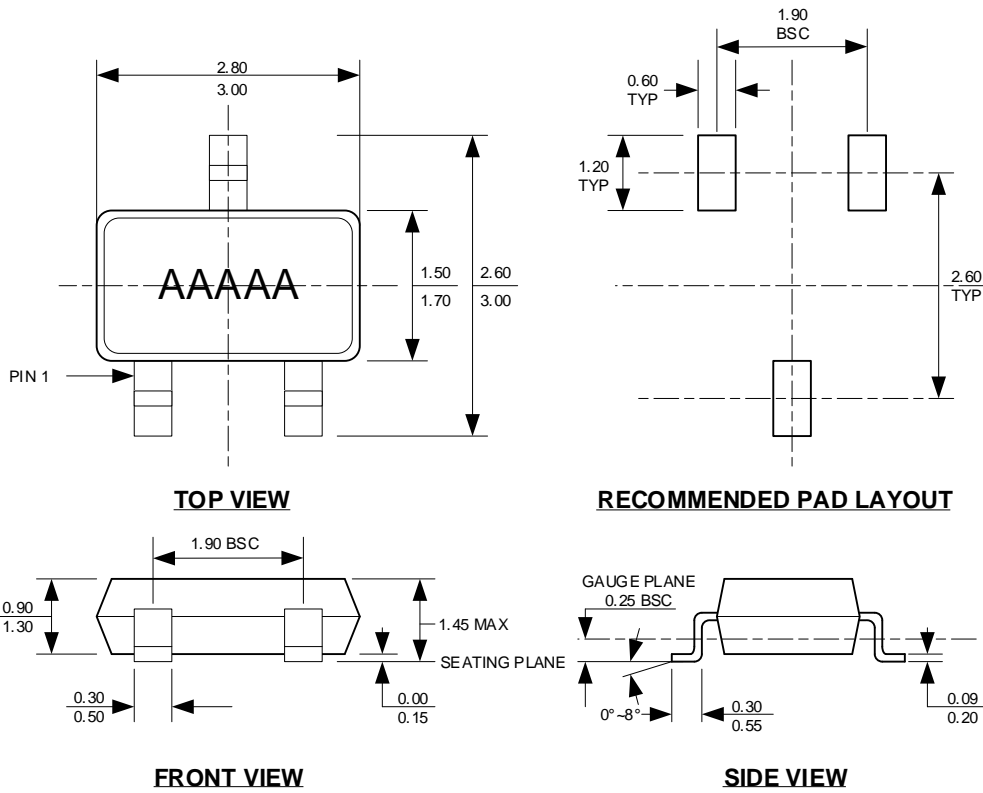

NOTE:

1. CONTROL DIMENSION IS IN INCHES. DIMENSION IN BRACKET IS IN MILLIMETERS.
2. PACKAGE LENGTH DOES NOT INCLUDE MOLD FLASH, PROTRUSIONS OR GATE BURRS.
3. PACKAGE WIDTH DOES NOT INCLUDE INTERLEAD FLASH OR PROTRUSIONS.
4. LEAD COPLANARITY (BOTTOM OF LEADS AFTER FORMING) SHALL BE 0.004" INCHES MAX.
5. DRAWING CONFORMS TO JEDEC MS-012, VARIATION BA.
6. DRAWING IS NOT TO SCALE.

30V High Side Over Voltage Protector

Package Description

SOT23-6

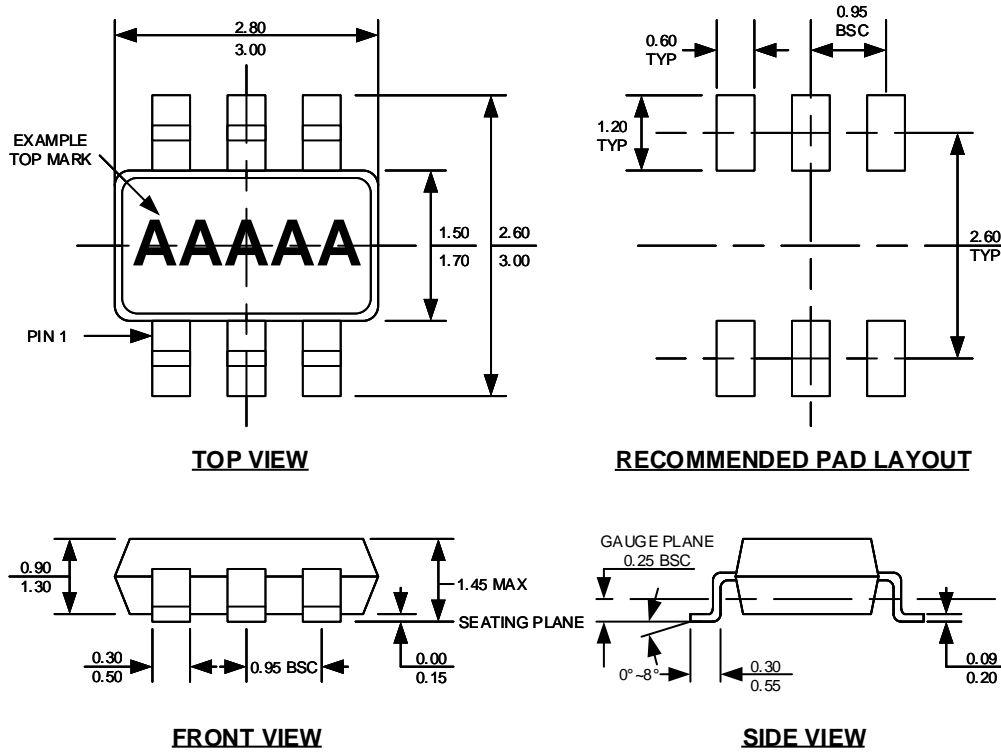

NOTE:

1. CONTROL DIMENSION IS IN INCHES. DIMENSION IN BRACKET IS IN MILLIMETERS.
2. PACKAGE LENGTH DOES NOT INCLUDE MOLD FLASH, PROTRUSIONS OR GATE BURRS.
3. PACKAGE WIDTH DOES NOT INCLUDE INTERLEAD FLASH OR PROTRUSIONS.
4. LEAD COPLANARITY (BOTTOM OF LEADS AFTER FORMING) SHALL BE 0.004" INCHES MAX.
5. DRAWING CONFORMS TO JEDEC MS-012, VARIATION BA.
6. DRAWING IS NOT TO SCALE.

X-ON Electronics

Largest Supplier of Electrical and Electronic Components

Click to view similar products for [Battery Management](#) category:

Click to view products by [RYCHIP](#) manufacturer:

Other Similar products are found below :

[NCP1851BFCCT1G](#) [NCP1855FCCT1G](#) [FAN54063UCX](#) [MP2615GQ-P](#) [LC05132C01NMTTTG](#) [ISL95522HRZ](#) [BD8665GW-E2](#)
[ISL95522AIRZ](#) [S-82D1AAE-A8T2U7](#) [S-82D1AAA-A8T2U7](#) [S-8224ABA-I8T1U](#) [MP2615CGQ-P](#) [ISL6251HRZ](#) [ISL6253HRZ](#) [ISL6292-2CR3](#) [ISL6292BCRZ-T](#) [ISL6299AIRZ](#) [ISL9211AIRU58XZ-T](#) [ISL9214IRZ](#) [ISL9220IRTZ-T](#) [FAN54161UCX](#) [DW01-A/J](#) [DW01A](#) [4056H](#)
[4056D](#) [TP4056](#) [TP4054](#) [TP4057](#) [IP2326_NPD](#) [IP2709_BF20WP](#) [TP4057](#) [TP4054](#) [TP4056-MS](#) [TP4057-MS](#) [TP4054-MS](#) [SY6982CQDC](#)
[SLM6335](#) [SLM6500S](#) [TP4057](#) [DW01](#) [AP5056HSPER](#) [EG4321](#) [GN4054B](#) [GN4054A](#) [HG4054M5/TR](#) [4060](#) [4061](#) [4061H](#) [4056A](#) [4056V](#)