

# 350mA High Speed Low Power LDO

## Features

- Programmable output: Minimum can go to 0.8V
- Highly Accurate:  $\pm 1.5\%$
- Dropout Voltage: 100mV @ 50mA (3.0V Typ.)
- High Ripple Rejection: 70dB @ 100Hz
- Internal protector: current limiter, short protector and over temperature protection
- Low Power Consumption: 50 $\mu$ A (Typ.)
- Minimum Output Current: 350mA ( $V_{IN} \geq V_{OUT} + 1V$ )
- Standby Current: less than 0.1 $\mu$ A
- Instructions with Power Good
- SOT23-5 and SOT23-6 packages

## Applications

- Cellular Handsets
- Battery-Powered Equipment
- Wi-Fi Router
- Hand-Held Instruments
- Portable Information Application
- Adjustable power supply

## General Description

The RY6212-ADJ series are highly precise, low noise, positive voltage LDO regulators manufactured using CMOS processes. The series achieves high ripple rejection and low dropout and consists of a standard voltage source, an error correction, current limiter and a phase compensation circuit plus a driver transistor. External output feedback, customers can easily get the required voltage. In order to make the load current does not exceed the current capacity of the output transistor, built-in over-current protection, over temperature protection and short circuit protection. RY6212-ADJ may have the POWER GOOD indicator. When the FB voltage reaches 0.75V, PG output is high. When the FB drops below 0.7V, PG output is low. The internal op amp with advanced structure, the output capacitor can be omitted.

## Typical Application Circuit <sup>(1)(2)</sup>

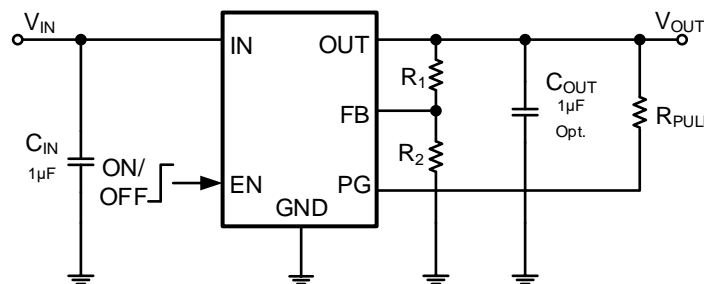

Figure1: Typical Application Circuit

Note1:  $V_{OUT} = 0.8 \times (1 + R1/R2)$

Note2:  $R2 \geq 100k\Omega$

# 350mA High Speed Low Power LDO

## Pin Description

## Pin Configuration

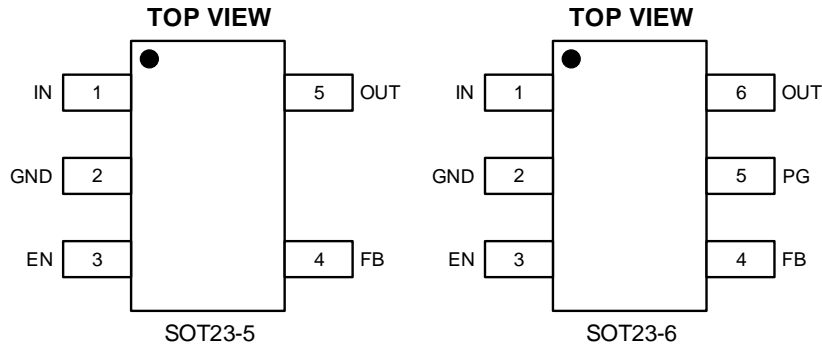

## Pin Description

Pin No.		Pin Name	Function
SOT23-5	SOT23-6		
1	1	IN	Input voltage pin for the regulator
2	2	GND	Ground
3	3	EN	Enable Control
4	4	FB	FB pin for adjustable output option
/	5	PG	Power Good Pin
5	6	OUT	Output voltage pin for the regulator

## Order Information <sup>(1)</sup>

### RY6212-ADJ<sup>①②</sup>

Designator	Symbol	Description		
ADJ	Integer	Output Voltage		
①	M5	SOT23-5		
	M6	SOT23-6		
②	R	RoHS / Pb Free		
	G	Halogen Free		
Part No.	Model	Description	Package	T/R Qty
70607009	RY6212-ADJM5R	RY6212-ADJM5R LDO, ADJ, SOT23-5	SOT23-5	3000PCS
70607010	RY6212-ADJM6R	RY6212-ADJM6R LDO, ADJ, SOT23-6	SOT23-6	3000PCS

Note (1): All RYCHIP parts are Pb-Free and adhere to the RoHS directive.

# 350mA High Speed Low Power LDO

## Mark Rule

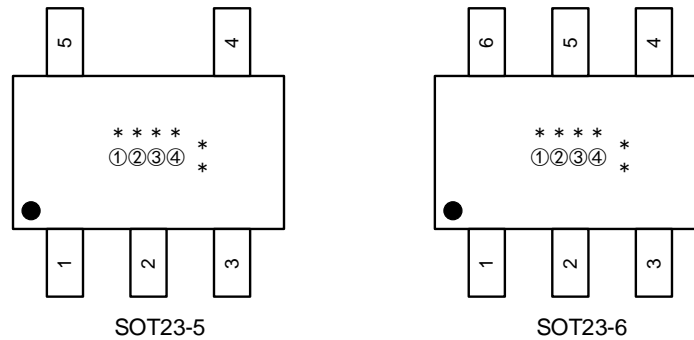

### Represents product series

Parameter	Mark	Description
①	4	RY6212-ADJ

### Represents active status

Parameter	Mark	Description
②	a	Active 'High' (pull-down resistor built in)
	b	Active 'High' (no pull-down resistor built in)
	c	Active 'Low' (pull-up resistor built in)
	d	Active 'Low' (no pull-up resistor built in)

### Represents PG function

Parameter	Mark	Description
③	a	Without PG
	p	With PG

### Represents customized code

Parameter	Mark	Description
④		Customized code

### Represents production lot number

Parameter	Mark	Description
*		Lot No.

# 350mA High Speed Low Power LDO

## Functional Block Diagram

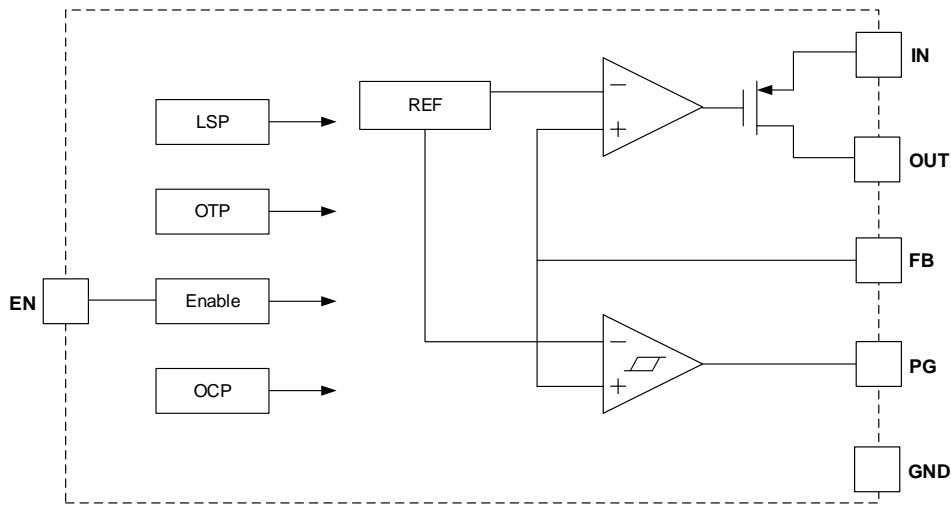

Functional Block Diagram

## Specifications

### Absolute Maximum Ratings <sup>(1)</sup> <sup>(2)</sup>

Item	Min	Max	Unit
V <sub>IN</sub> voltage	2.0	8.0	V
V <sub>OUT</sub> voltage	1.2	3.3	V
Output Current <sup>(3)</sup>	350		mA
Power dissipation <sup>(4)</sup>	Internally Limited		
Operating Ambient Temperature	-40	85	°C
Maximum junction temperature		150	°C
Storage temperature, T <sub>stg</sub>	-50	85	°C
Lead Temperature (Soldering, 10sec.)		260	°C

Note (1): Exceeding these ratings may damage the device.

Note (2): The device is not guaranteed to function outside of its operating conditions.

Note (3):  $I_{OUT} = P_D / (V_{IN} - V_{OUT})$

Note (4): The maximum allowable power dissipation is a function of the maximum junction temperature, T<sub>J(MAX)</sub>, the junction-to-ambient thermal resistance, R<sub>θJA</sub>, and the ambient temperature, T<sub>A</sub>. The maximum allowable power dissipation at any ambient temperature is calculated using:  $P_{D(MAX)} = (T_{J(MAX)} - T_A) / R_{\theta JA}$ . Exceeding the maximum allowable power dissipation causes excessive die temperature, and the regulator goes into thermal shutdown. Internal thermal shutdown circuitry protects the device from permanent damage. Thermal shutdown engages at T<sub>J</sub>=155°C (typical) and disengages at T<sub>J</sub>= 140°C (typical).

# 350mA High Speed Low Power LDO

## Recommended Operating Conditions

Item	Min	Max	Unit
Operating junction temperature <sup>(1)</sup>	-40	125	°C
Operating temperature range	-40	85	°C
Input voltage V <sub>IN</sub>	2	6.5	V
Output current	0	300	mA

Note (1): All limits specified at room temperature (T<sub>A</sub> = 25°C) unless otherwise specified. All room temperature limits are 100% production tested. All limits at temperature extremes are ensured through correlation using standard Statistical Quality Control (SQC) methods. All limits are used to calculate Average Outgoing Quality Level (AOQL).

## Thermal Information

Item	Description	SOT23 5 Pin	SOT23 6 Pin	Unit
R <sub>θJA</sub>	Junction-to-ambient thermal resistance <sup>(1)(2)</sup>	230	105	°C/W
R <sub>θJC(top)</sub>	Junction-to-case (top) thermal resistance	152	55	°C/W
R <sub>θJB</sub>	Junction-to-board thermal resistance	56	17.5	°C/W
Ψ <sub>JT</sub>	Junction-to-top characterization parameter	31	3.5	°C/W
Ψ <sub>JB</sub>	Junction-to-board characterization parameter	55	17.5	°C/W
R <sub>θJC(bot)</sub>	Junction-to-case (bottom) thermal resistance	N/A	N/A	°C/W

Note (1): The package thermal impedance is calculated in accordance to JESD 51-7.

Note (2): Thermal Resistances were simulated on a 4-layer, JEDEC board

# 350mA High Speed Low Power LDO

## Electrical Characteristics

T<sub>A</sub> = 25°C, unless otherwise noted.

Parameter	Symbol	Test Conditions	Min	Typ.	Max	Units	
Input Voltage	V <sub>IN</sub>		2		6.5	V	
Feedback Voltage	V <sub>FB</sub>	V <sub>IN</sub> =4.2V, V <sub>OUT</sub> =3.3V, I <sub>OUT</sub> =30mA	790	800	810	mV	
Output Current	I <sub>OUT</sub>	V <sub>IN</sub> ≥V <sub>OUT(S)</sub> +1.0V		350		mA	
Dropout Voltage	V <sub>drop</sub>	I <sub>OUT</sub> =50 mA	-	0.10	0.15	V	
		I <sub>OUT</sub> =100 mA	-	0.20	0.30		
Line Regulations	$\frac{\Delta V_{OUT}}{\Delta V_{IN} \times V_{OUT}}$	V <sub>OUT(S)</sub> +0.5 V≤V <sub>IN</sub> ≤7V I <sub>OUT</sub> =30mA	-	0.20	0.30	%/V	
Load Regulation	ΔV <sub>OUT</sub>	V <sub>IN</sub> =V <sub>OUT(S)</sub> +1.0 V 1.0mA≤I <sub>OUT</sub> ≤100mA	-	50	100	mV	
Output Voltage Temperature Characteristics	$\frac{\Delta V_{OUT}}{T_A \times V_{OUT}}$	V <sub>IN</sub> =V <sub>OUT(S)</sub> +1.0V, I <sub>OUT</sub> =10mA -40°C≤T <sub>A</sub> ≤85°C	-	±100	-	ppm/ °C	
Supply Current	I <sub>SS1</sub>	V <sub>IN</sub> =V <sub>OUT(S)</sub> +1.0 V	-	50	70	μA	
Shutdown Current	I <sub>shut</sub>	V <sub>IN</sub> =5V, V <sub>EN</sub> =0			0.1	μA	
Power Supply Rejection Ratio	PSRR	V <sub>OUT</sub> =1.2V, V <sub>IN</sub> =2V	f = 100Hz	-	70	-	dB
			f = 1kHz		65	-	dB
Output Voltage Noise (BW=10Hz to 100kHz, C <sub>OUT</sub> =10μF)		V <sub>IN</sub> = 3.5V I <sub>LOAD</sub> =0.1A	V <sub>OUT</sub> =0.9V		30		μV <sub>RMS</sub>
			V <sub>OUT</sub> =2.8V		40		
Short-circuit Current	I <sub>short</sub>	V <sub>IN</sub> =V <sub>OUT(S)</sub> +1.0V, ON/OFF Terminal is ON, V <sub>OUT</sub> =0V	-	100	-	mA	
EN “High Voltage	V <sub>ENH</sub>		0.9			V	
EN “Low” Voltage	V <sub>ENL</sub>				0.4	V	
EN “High Current	I <sub>ENH</sub>	V <sub>IN</sub> =V <sub>EN</sub> =V <sub>OUT(T)</sub> +1V	-0.1		0.1	μA	
EN “Low” Current	I <sub>ENL</sub>	V <sub>IN</sub> =V <sub>OUT(T)</sub> +1V, V <sub>EN</sub> =V <sub>SS</sub>	-0.1		0.1	μA	
Thermal Shutdown Temperature	T <sub>SD</sub>	I <sub>LOAD</sub> =10mA		155		°C	
Thermal Shutdown Hysteresis	ΔT <sub>SD</sub>				15		°C

# 350mA High Speed Low Power LDO

## Typical Performance Characteristics (8)

Note (8): Typical performance characteristics below based on Output Voltage=3.3V

1、 The input voltage transient response

Test Conditions: Vin=4.3V-5.3V, Iout=10mA, Cin=Cout=1uF

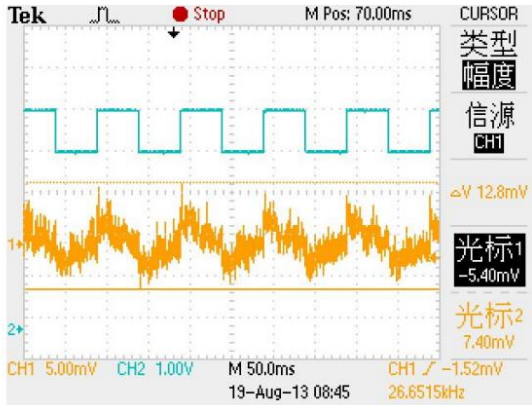

Channel 2 input, channel 1 Output

2、 Ripple rejection

Test Conditions: Vin=4.3V-5.3V, Iout=10mA, Cin=Cout=1uF

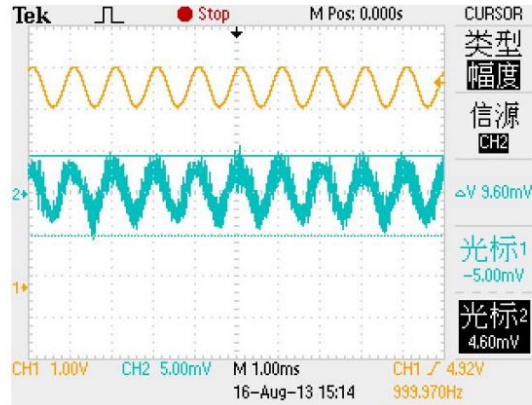

Channel 1 input, channel 2 Output

3、 The load transient response

Test Conditions: Vin=CE=4.3V, Cin=Cout=1uF, Iout=0-100mA

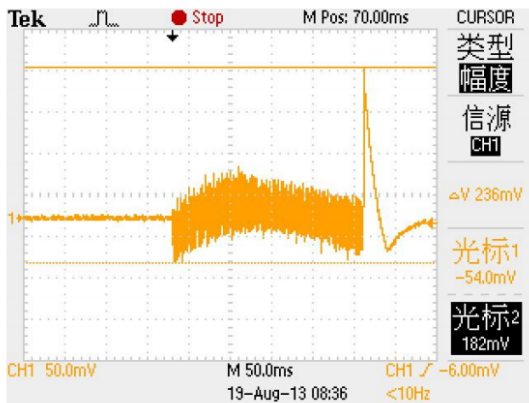

4、 The output voltage temperature curve

Test Conditions: Vin=CE=4.3V, Cin=Cout=1uF, Iout=10mA

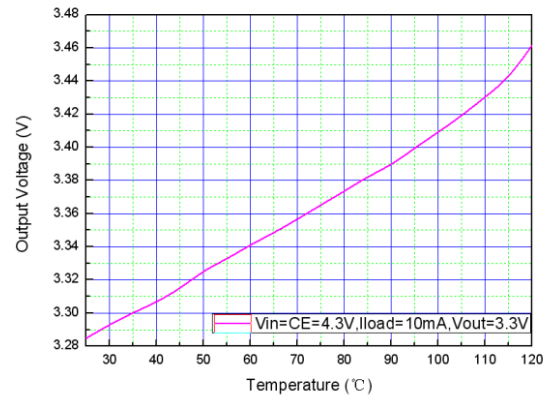

5、 Overshoot

Test Conditions: Vin=0V-4.3V, Iout=0mA, Cin=Cout=1uF

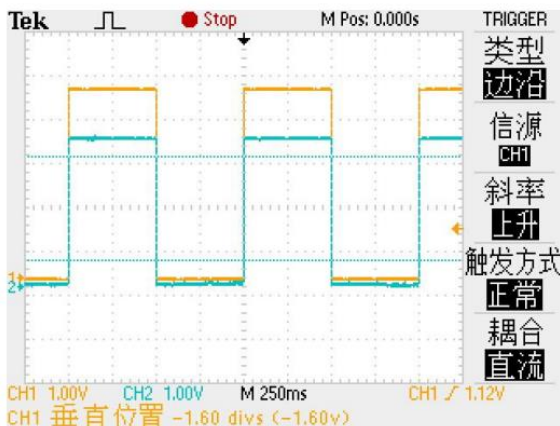

Channel 1 input, channel 2 Output

# 350mA High Speed Low Power LDO

## Applications Information

### Setting the Output Voltage

RY6212-ADJ require an input capacitor and an output capacitor. These components are critical to the performance of the device. The output voltage can be programmed by resistor divider.

$$V_{OUT} = V_{FB} \times \frac{R1 + R2}{R2}$$

V <sub>OUT</sub> (V)	R1(KΩ)	R2(KΩ)	C <sub>IN</sub> (μF)	C <sub>OUT</sub> (μF)
1	25.00	100	1~10	1~10
1.05	31.25	100	1~10	1~10
1.2	50.00	100	1~10	1~10
1.5	87.50	100	1~10	1~10
1.8	125.00	100	1~10	1~10
2.5	212.50	100	1~10	1~10
2.8	250.00	100	1~10	1~10
3.3	312.50	100	1~10	1~10
3.6	350.00	100	1~10	1~10

### Low ESR Capacitors

With the RY6212-ADJ series, a stable output voltage is achievable even if used with low ESR capacitors as a phase compensation circuit is built-in. In order to ensure the effectiveness of the phase compensation, we suggest that an output capacitor (C<sub>OUT</sub>) is connected as close as possible to the output pin (V<sub>OUT</sub>) and the GND pin. Please use an output capacitor with a capacitance value of 10uF. Also, please connect an input capacitor (C<sub>IN</sub>) of 10uF between the V<sub>IN</sub> pin and the GND pin in order to ensure a stable power input. Stable phase compensation may not be ensured if the capacitor runs out capacitance when depending on bias and temperature. In case the capacitor depends on the bias and temperature, please make sure the capacitor can ensure the actual capacitance.

### Current Limiter, Short-Circuit Protection

The RY6212-ADJ series includes a combination of a fixed current limiter circuit & a feedback circuit, which aid the operations of the current limiter and circuit protection. When the load current reaches the current limit level, the fixed current limiter circuit operates and output voltage drops. As a result of this drop-in output voltage, the feedback circuit operates, output voltage drops further and output current decreases. When the output pin is shorted, a current of about 50mA flows.

### EN pin

The IC's internal circuitry can be shutdown via the signal from the EN pin with the RY6212-ADJ series. Driving EN over 0.9 V turns on the regulator. Driving EN below 0.4 V puts the regulator into shutdown mode. The operational logic of the IC's EN pin is selectable. Note that as the standard RY6212-ADJ type's regulator is 'High Active/No Pull-Down', operations will become unstable with the EN pin open. Although the EN pin is equal to an inverter input with CMOS hysteresis, with either the pull-up or pull-down options, the EN pin input current will



## 350mA High Speed Low Power LDO

increase when the IC is in operation. We suggest that you use this IC with either a  $V_{IN}$  voltage or a GND voltage input at the EN pin. If this IC is used with the correct specifications for the EN pin, the operational logic is fixed and the IC will operate normally. However, supply current may increase as a result of through current in the IC's internal circuitry.

### Notes on Use

1. Please use this IC within the stated absolute maximum ratings. The IC is liable to malfunction should the ratings be exceeded.
2. Where wiring impedance is high, operations may become unstable due to noise and/or phase lag depending on output current. Please keep the resistance low between  $V_{IN}$  and GND wiring in particular.
3. Please wire the input capacitor ( $C_{IN}$ ) and the output capacitor ( $C_{OUT}$ ) as close to the IC as possible.

# 350mA High Speed Low Power LDO

## Packaging Information

### 5-Pin SOT23 Packaging Information

#### SOT23-5

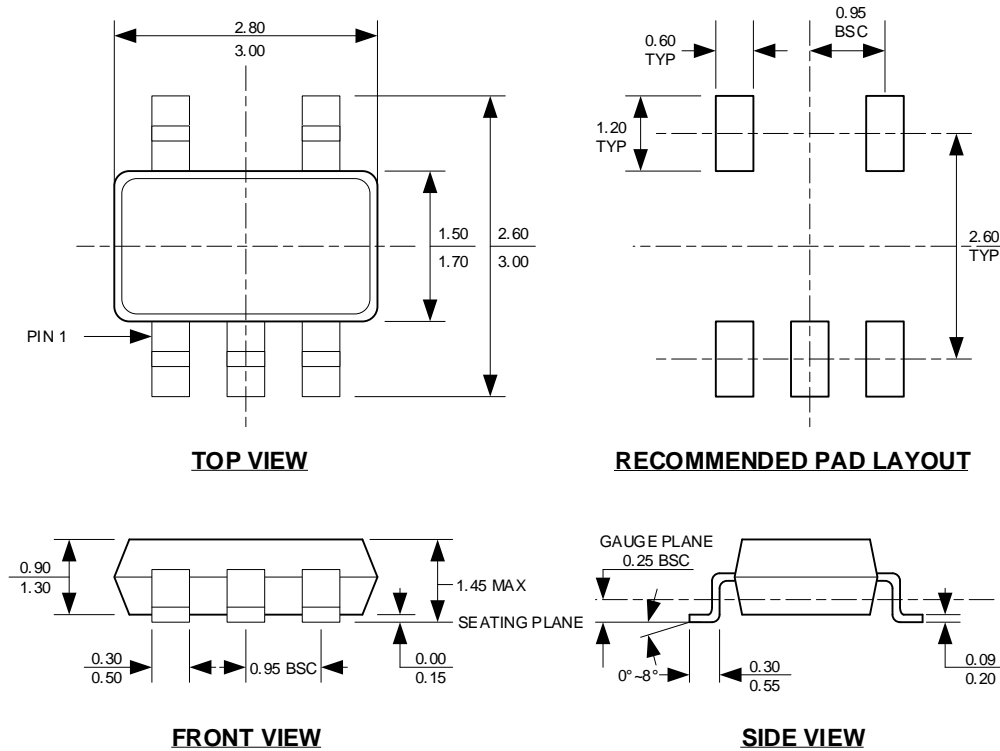

**NOTE:**

1. CONTROL DIMENSION IS IN INCHES. DIMENSION IN BRACKET IS IN MILLIMETERS.
2. PACKAGE LENGTH DOES NOT INCLUDE MOLD FLASH, PROTRUSIONS OR GATE BURRS.
3. PACKAGE WIDTH DOES NOT INCLUDE INTERLEAD FLASH OR PROTRUSIONS.
4. LEAD COPLANARITY (BOTTOM OF LEADS AFTER FORMING) SHALL BE 0.004" INCHES MAX.
5. DRAWING CONFORMS TO JEDEC MS-012, VARIATION BA.
6. DRAWING IS NOT TO SCALE.

# 350mA High Speed Low Power LDO

## 5-Pin SOT23 Packaging Information

### SOT23-6

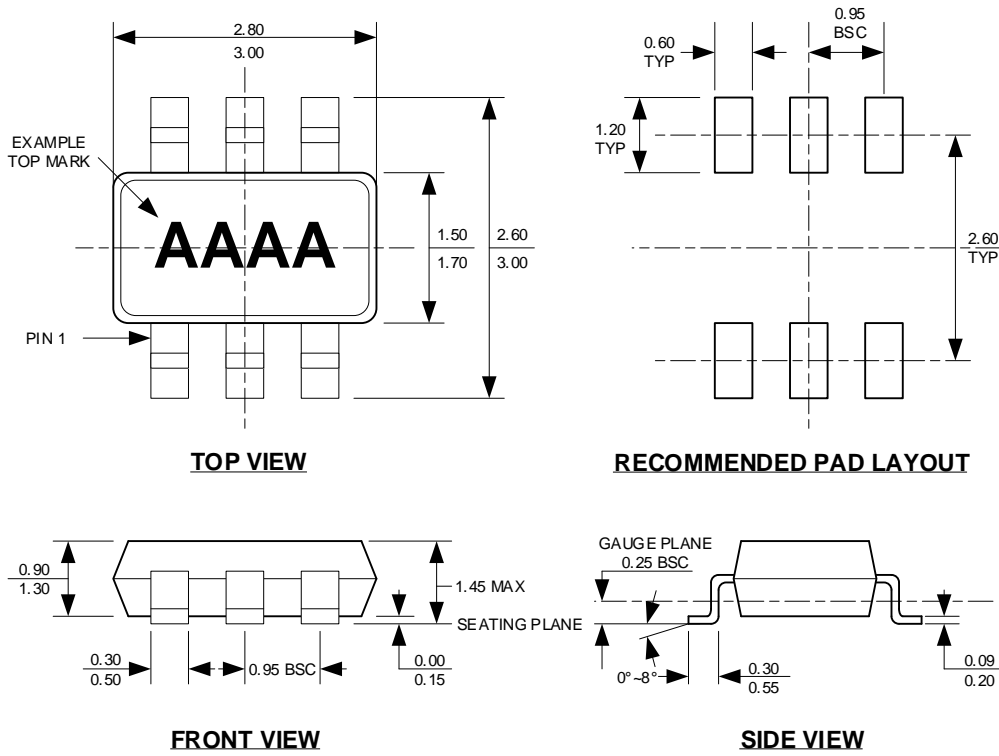

**NOTE:**

1. CONTROL DIMENSION IS IN INCHES. DIMENSION IN BRACKET IS IN MILLIMETERS.
2. PACKAGE LENGTH DOES NOT INCLUDE MOLD FLASH, PROTRUSIONS OR GATE BURRS.
3. PACKAGE WIDTH DOES NOT INCLUDE INTERLEAD FLASH OR PROTRUSIONS.
4. LEAD COPLANARITY (BOTTOM OF LEADS AFTER FORMING) SHALL BE 0.004" INCHES MAX.
5. DRAWING CONFORMS TO JEDEC MS-012, VARIATION BA.
6. DRAWING IS NOT TO SCALE.

## X-ON Electronics

Largest Supplier of Electrical and Electronic Components

*Click to view similar products for [Linear Voltage Regulators](#) category:*

*Click to view products by [RYCHIP](#) manufacturer:*

Other Similar products are found below :

[LV56831P-E](#) [LV5684PVD-XH](#) [MCDTSA6-2R](#) [L7815ACV-DG](#) [PQ3DZ53U](#) [LV56801P-E](#) [TLE42794G](#) [L78L05CZ/1SX](#) [L78LR05DL-MA-E](#) [636416C](#) [714954EB](#) [ZMR500QFTA](#) [LV5680P-E](#) [L78M15CV-DG](#) [L79M05T-E](#) [TLS202A1MBVHTSA1](#) [L78LR05D-MA-E](#) [NCV317MBTG](#) [NTE7227](#) [MP2018GZD-33-P](#) [MP2018GZD-5-P](#) [LV5680NPVC-XH](#) [LT1054CN8](#) [MP2018GZD-5-Z](#) [MP2018GZD-33-Z](#) [AT55EL50ESE](#) [APL5934DKAI-TRG](#) [78L05U](#) [78L05](#) [CL9193A15L5M](#) [CL9036A30F4M](#) [CL9036A18F4M](#) [CL9036A25F4M](#) [CL9036A28F4M](#) [CL9036A33F4M](#) [CL9906A18F4N](#) [CL9906A30F4N](#) [CL9908A30F4M](#) [CL9908A33F4M](#) [CL9908A18F4M](#) [CL9908A28F4M](#) [TL431ACM/TR](#) [TL431AIM/TR](#) [LM78L05ACM/TR](#) [HT7812ARMZ](#) [HT7805ARMZ](#) [HT317LRHZ](#) [HXY6206I-3.0](#) [HXY6206I-3.3](#) [XC6206P252MR](#) [XC6206P282MR](#)