

Samsung eMMC Product family

eMMC 5.1 Specification compatibility

datasheet

SAMSUNG ELECTRONICS RESERVES THE RIGHT TO CHANGE PRODUCTS, INFORMATION AND SPECIFICATIONS WITHOUT NOTICE.

Products and specifications discussed herein are for reference purposes only. All information discussed herein is provided on an "AS IS" basis, without warranties of any kind.

This document and all information discussed herein remain the sole and exclusive property of Samsung Electronics. No license of any patent, copyright, mask work, trademark or any other intellectual property right is granted by one party to the other party under this document, by implication, estoppel or otherwise.

Samsung products are not intended for use in life support, critical care, medical, safety equipment, or similar applications where product failure could result in loss of life or personal or physical harm, or any military or defense application, or any governmental procurement to which special terms or provisions may apply.

For updates or additional information about Samsung products, contact your nearest Samsung office.

All brand names, trademarks and registered trademarks belong to their respective owners.

© 2017 Samsung Electronics Co., Ltd. All rights reserved

Revision History

<u>Revision No.</u>	<u>History</u>	<u>Draft Date</u>	<u>Remark</u>	<u>Editor</u>
0.0	1. Initial issue	Aug. 22, 2016	Target	S.M.Lee
1.0	1. Customer sample	Nov. 15,2016	Final	S.M.Lee
1.1	1. 8GB is added (Customer sample)	Dec. 12,2016	Final	S.M.Lee
1.2	1. Typo correction	Jan. 26, 2017	Final	S.M.Lee

Table Of Contents

1.0 PRODUCT LIST 4

2.0 KEY FEATURES 4

3.0 PACKAGE CONFIGURATIONS 5

 3.1 153 Ball Pin Configuration 5

 3.1.1 11.5mm x 13mm x 0.8mm Package Dimension [8GB /16GB] 6

 3.1.2 11.5mm x 13mm x 0.8mm Package Dimension [32GB] 6

 3.1.3 11.5mm x 13mm x 1.0mm Package Dimension [64GB] 7

 3.2 Product Architecture 8

4.0 HS400 mode 9

5.0 New eMMC5.1 Features 10

 5.1 Overview 10

 5.2 Command Queuing 10

 5.2.1 CMD Set Description 10

 5.2.2 New Response : QSR (Queue Status Register) 10

 5.2.3 Send Status : CMD13 10

 5.2.4 Mechanism of CMD Queue operation 11

 5.2.5 CMD Queue Register description 11

 5.3 Enhanced Strobe Mode 11

 5.4 RPMB Throughput improve 11

 5.5 Secure Write Protection 12

6.0 Technical Notes 13

 6.1 S/W Algorithm 13

 6.1.1 Partition Management 13

 6.1.1.1 Enhanced Partition (Area) 13

 6.1.2 Boot operation 13

 6.1.3 User Density 14

 6.1.4 Auto Power Saving Mode 15

 6.1.5 Performance 15

7.0 REGISTER VALUE 16

 7.1 OCR Register 16

 7.2 CID Register 16

 7.2.1 Product name table (In CID Register) 16

 7.3 CSD Register 17

 7.4 Extended CSD Register 18

8.0 AC PARAMETER 23

 8.1 Timing Parameter 23

 8.2 Previous Bus Timing Parameters for DDR52 and HS200 mode are defined by JEDEC standard 23

 8.3 Bus Timing Specification in HS400 mode 24

 8.3.1 HS400 Device Input Timing 24

 8.3.2 HS400 Device Output Timing 25

 8.4 Bus signal levels 26

 8.4.1 Open-drain mode bus signal level 26

 8.4.2 Push-pull mode bus signal level eMMC 26

9.0 DC PARAMETER 27

 9.1 Active Power Consumption during operation 27

 9.2 Standby Power Consumption in auto power saving mode and standby state 27

 9.3 Sleep Power Consumption in Sleep State 27

 9.4 Supply Voltage 27

 9.5 Bus Signal Line Load 28

IF THERE IS ANY OTHER OPERATION TO IMPLEMENT IN ADDITION TO SPECIFICATION IN THE DATASHEET OR JEDEC STANDARD, PLEASE CONTACT EACH BRANCH OFFICE OR HEADQUARTERS OF SAMSUNG ELECTRONICS.

INTRODUCTION

SAMSUNG eMMC is an embedded MMC solution designed in a BGA package form. eMMC operation is identical to a MMC device and therefore is a simple read and write to memory using MMC protocol v5.1 which is a industry standard.

eMMC consists of NAND flash and a MMC controller. 3V supply voltage is required for the NAND area (V_{DDF} or V_{CC}) whereas 1.8V or 3V dual supply voltage (V_{DD} or V_{CCQ}) is supported for the MMC controller. SAMSUNG eMMC supports HS400 in order to improve sequential bandwidth, especially sequential read performance.

There are several advantages of using eMMC. It is easy to use as the MMC interface allows easy integration with any microprocessor with MMC host. Any revision or amendment of NAND is invisible to the host as the embedded MMC controller insulates NAND technology from the host. This leads to faster product development as well as faster times to market.

The embedded flash management software or FTL(Flash Transition Layer) of eMMC manages Wear Leveling, Bad Block Management and ECC. The FTL supports all features of the Samsung NAND flash and achieves optimal performance.

1.0 PRODUCT LIST

[Table 1] Product List

Capacities	eMMC Part ID	NAND Flash Type	User Density (%)	Power System	Package size	Pin Configuration
8 GB	KLM8G1GETF-B041	64Gb x 1	91.0%	- Interface power : VDD (1.70V ~ 1.95V or 2.7V ~ 3.6V) - Memory power : VDDF (2.7V ~ 3.6V)	11.5mm x 13mm x 0.8mm	153FBGA
16 GB	KLMAG1JETD-B041	128Gb x 1				
32 GB	KLMBG2JETD-B041	128Gb x 2				
64 GB	KLMCG4JETD-B041	128Gb x 4			11.5mm x 13mm x 1.0mm	

2.0 KEY FEATURES

- embedded MultiMediaCard Ver. 5.1 compatible.
- SAMSUNG eMMC supports features of eMMC5.1 which are defined in JEDEC Standard
 - Major Supported Features : HS400, Field Firmware Update, Cache, Command Queuing, Enhanced Strobe Mode, Secure Write Protection, Partition types.
 - Non-supported Features : Large Sector Size (4KB)
- Backward compatibility with previous MultiMediaCard system specification (1bit data bus, multi-eMMC systems)
- Data bus width : 1bit (Default), 4bit and 8bit
- MMC I/F Clock Frequency : 0 ~ 200MHz
 MMC I/F Boot Frequency : 0 ~ 52MHz
- Temperature : Operation (-25°C ~ 85°C), Storage without operation (-40°C ~ 85°C)
- Power : Interface power → V_{CCQ} (1.70V ~ 1.95V) , Memory power → V_{CC} (2.7V ~ 3.6V)

IF THERE IS ANY OTHER OPERATION TO IMPLEMENT IN ADDITION TO SPECIFICATION IN THE DATASHEET OR JEDEC STANDARD, PLEASE CONTACT EACH BRANCH OFFICE OR HEADQUARTERS OF SAMSUNG ELECTRONICS.

3.0 PACKAGE CONFIGURATIONS

3.1 153 Ball Pin Configuration

[Table 2] 153 Ball Information

Pin NO	Name
A3	DAT0
A4	DAT1
A5	DAT2
B2	DAT3
B3	DAT4
B4	DAT5
B5	DAT6
B6	DAT7
K5	RSTN
C6	V _{CCQ}
M4	V _{CCQ}
N4	V _{CCQ}
P3	V _{CCQ}
P5	V _{CCQ}
E6	V _{CC}
F5	V _{CC}
J10	V _{CC}
K9	V _{CC}
C2	VDDI
M5	CMD
H5	Data Strobe
M6	CLK
J5	V _{SS}
A6	V _{SS}
C4	V _{SS}
E7	V _{SS}
G5	V _{SS}
H10	V _{SS}
K8	V _{SS}
N2	V _{SS}
N5	V _{SS}
P4	V _{SS}
P6	V _{SS}

Ball-side down view

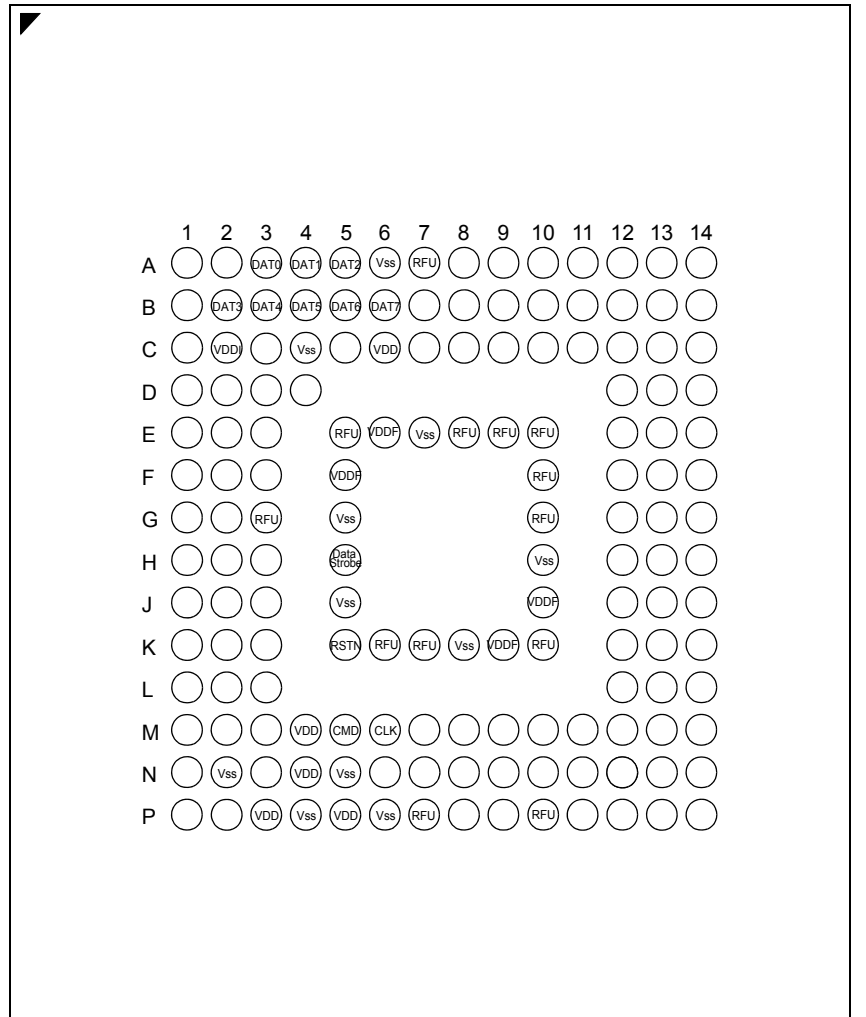

Figure 1. 153-FBGA

- CLK : Clock input
- Data Strobe : Data Strobe is generated from eMMC to host.
 In HS400 mode, read data and CRC response are synchronized with Data Strobe.
- CMD : A bidirectional signal used for device initialization and command transfers.
 Command operates in two modes, open-drain for initialization and push-pull for fast command transfer.
- DAT0-7 : Bidirectional data channels. It operates in push-pull mode.
- RST_n : H/W reset signal pin
- V_{CC} : Supply voltage for flash memory
- V_{CCQ} : Supply voltage for memory controller
- VDDi : Internal power node to stabilize regulator output to controller core logics
- V_{SS} : Ground connections
- RFU : Reserved for future use , do not use for any usage

IF THERE IS ANY OTHER OPERATION TO IMPLEMENT IN ADDITION TO SPECIFICATION IN THE DATASHEET OR JEDEC STANDARD, PLEASE CONTACT EACH BRANCH OFFICE OR HEADQUARTERS OF SAMSUNG ELECTRONICS.

3.1.1 11.5mm x 13mm x 0.8mm Package Dimension [8GB / 16GB]

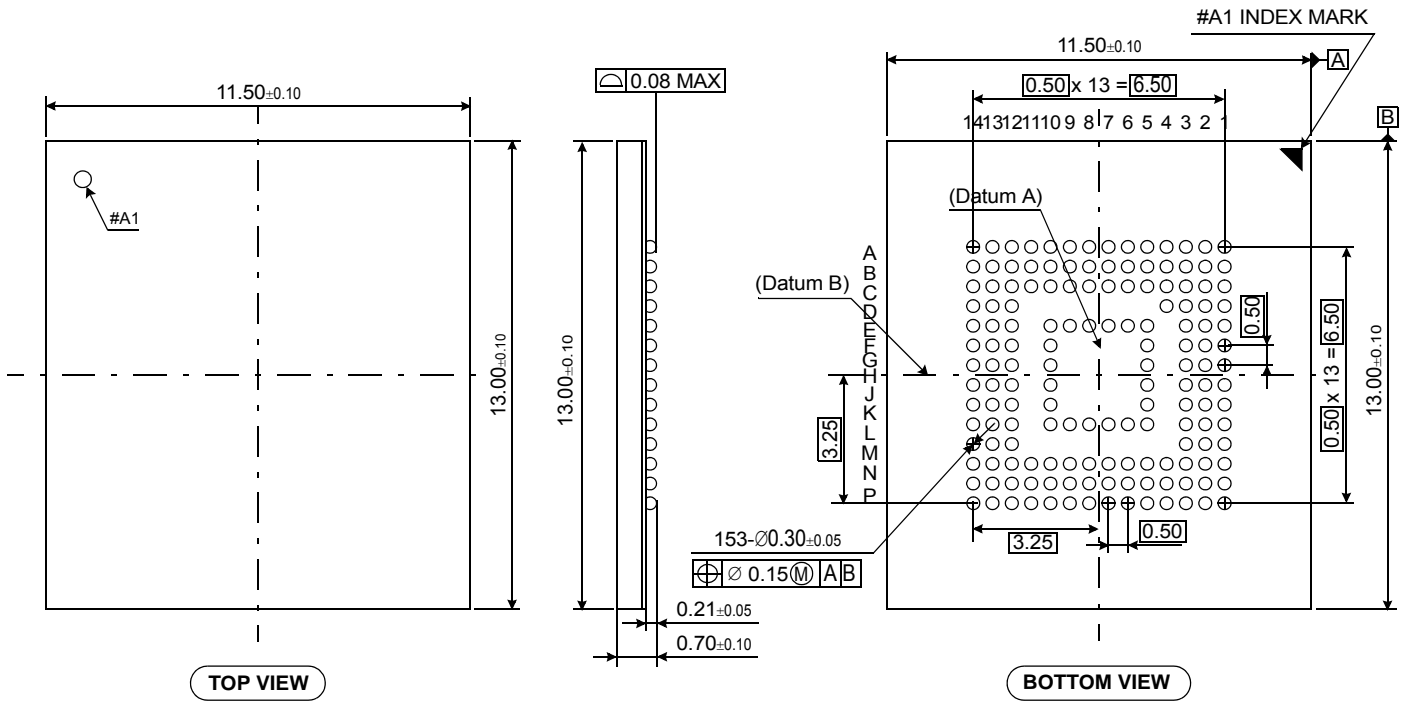

Figure 2. 11.5mm x 13mm x 0.8mm Package Dimension

3.1.2 11.5mm x 13mm x 0.8mm Package Dimension [32GB]

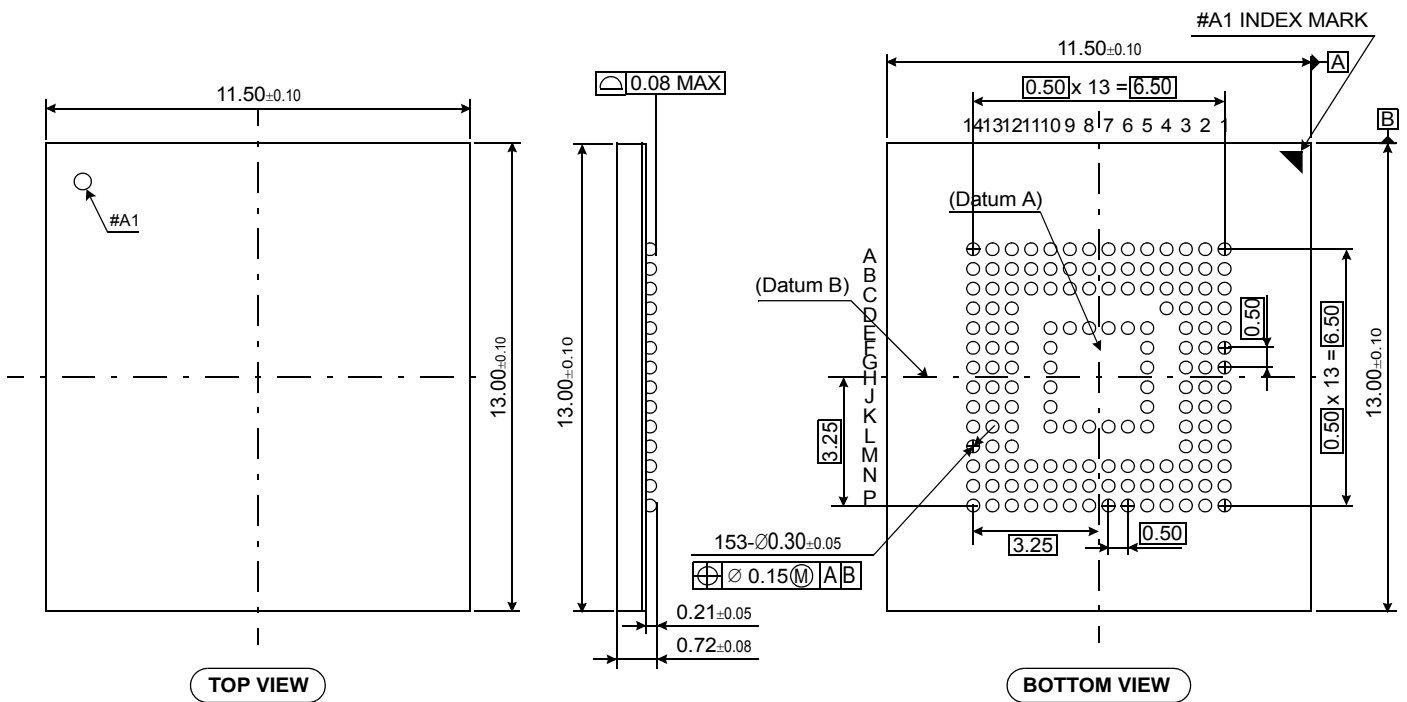

Figure 3. 11.5mm x 13mm x 0.8mm Package Dimension

IF THERE IS ANY OTHER OPERATION TO IMPLEMENT IN ADDITION TO SPECIFICATION IN THE DATASHEET OR JEDEC STANDARD, PLEASE CONTACT EACH BRANCH OFFICE OR HEADQUARTERS OF SAMSUNG ELECTRONICS.

datasheet

3.1.3 11.5mm x 13mm x 1.0mm Package Dimension [64GB]

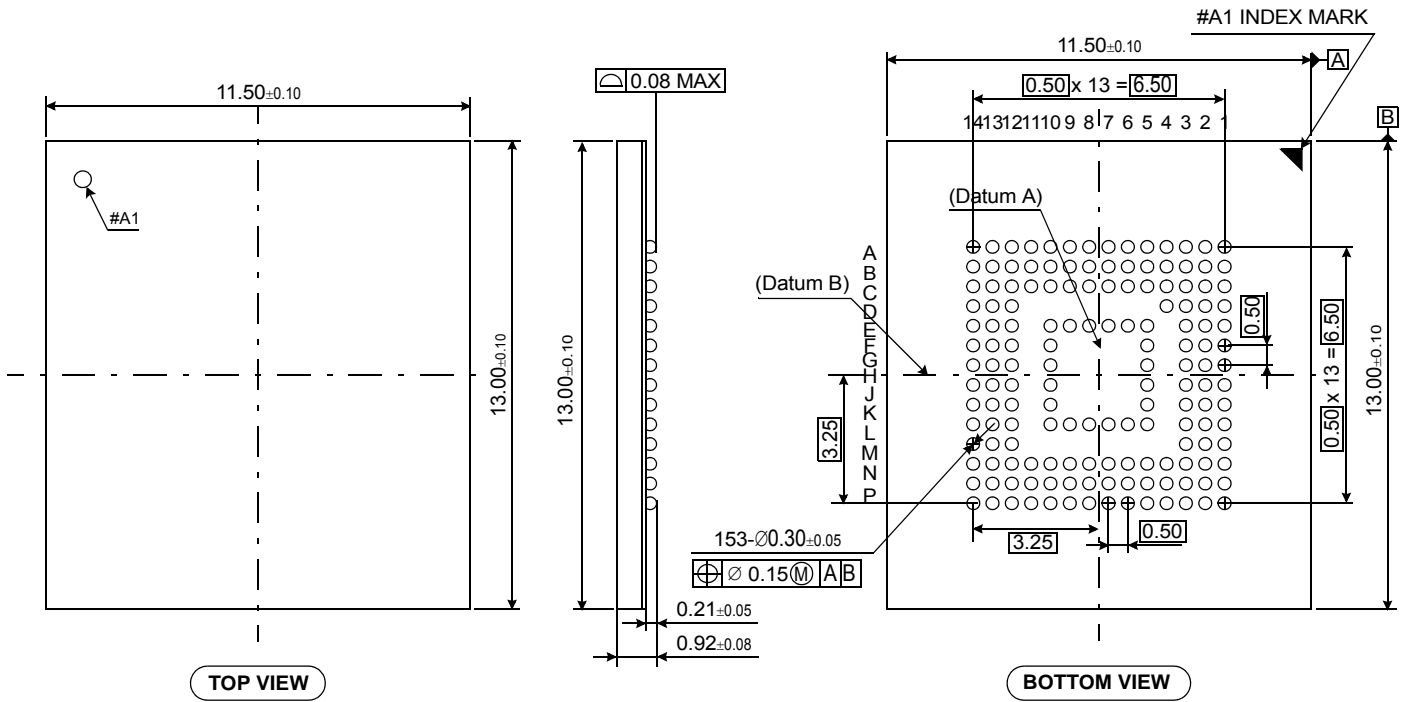

Figure 4. 11.5mm x 13mm x 1.0mm Package Dimension

IF THERE IS ANY OTHER OPERATION TO IMPLEMENT IN ADDITION TO SPECIFICATION IN THE DATASHEET OR JEDEC STANDARD, PLEASE CONTACT EACH BRANCH OFFICE OR HEADQUARTERS OF SAMSUNG ELECTRONICS.

3.2 Product Architecture

- eMMC consists of NAND Flash and Controller. V_{CCQ} is for Controller power and V_{CC} is for flash power

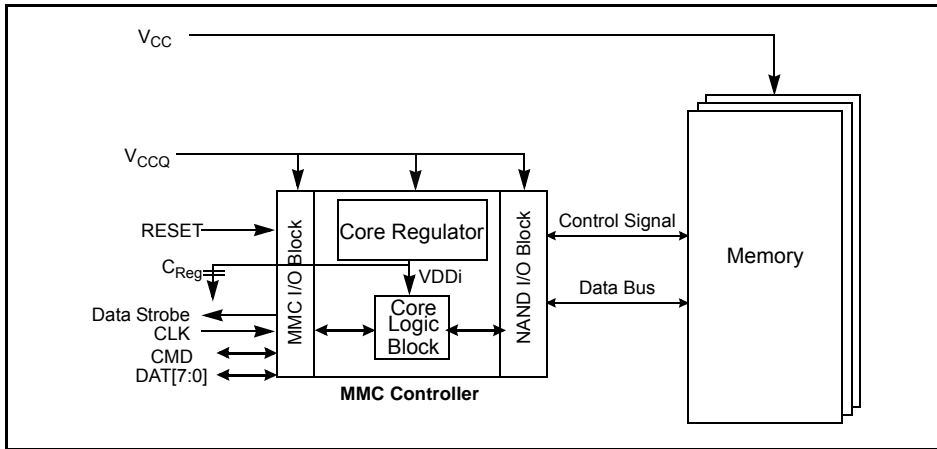

Figure 5. eMMC Block Diagram

4.0 HS400 mode

eMMC5.0 product supports high speed DDR interface timing mode up to 400MB/s at 200MHz with 1.8V I/O supply.
 HS400 mode supports the following features :

- DDR Data sampling method
- CLK frequency up to 200MHz DDR (up to 400Mbps)
- Only 8-bits bus width available
- Signaling levels of 1.8V
- Six selectable Drive Strength (refer to the table below)

[Table 3] I/O driver strength types

Driver Type	HS200 & HS400 Support	Nominal Impedance	Approximated driving capability compared to Type-0	Remark
0	Default	50Ω	x1	Default Driver Type. Supports up to 200MHz operation.
1	Optional	33Ω	x1.5	Supports up to 200MHz Operation.
2	Optional	66Ω	x0.75	The weakest driver that supports up to 200MHz operation.
3	Optional	100Ω	x0.5	For low noise and low EMI systems. Maximal operating frequency is decided by Host design.
4	Optional	40Ω	x1.2	Supports up to 200MHz DDR operation

NOTE:

1) Support of Driver Type-0 is default for HS200 & HS400 Device, while supporting Driver types 1~4 are optional for HS200 & HS400 Device.

[Table 4] Device type values (EXT_CSD register : DEVICE_TYPE [196])

Bit	Device Type	Supportability
7	HS400 Dual Data Rate eMMC @ 200 MHz - 1.2V I/O	Not support
6	HS400 Dual Data Rate eMMC @ 200 MHz - 1.8V I/O	Support
5	HS200 Single Data Rate eMMC @ 200 MHz - 1.2V I/O	Not support
4	HS200 Single Data Rate eMMC @ 200 MHz - 1.8V I/O	Support
3	High-Speed Dual Data Rate eMMC @ 52MHz - 1.2V I/O	Not support
2	High-Speed Dual Data Rate eMMC @ 52MHz - 1.8V or 3V I/O	Support
1	High-Speed eMMC @ 52MHz - at rated device voltage(s)	Support
0	High-Speed eMMC @ 26MHz - at rated device voltage(s)	Support

[Table 5] Extended CSD revisions (EXT_CSD register : EXT_CSD_REV [192])

Value	Timing Interface	EXT_CSD Register Value
255-8	Reserved	-
8	Revision 1.8 (for MMC V5.1)	0x08
7	Revision 1.7 (for MMC V5.0)	-
6	Revision 1.6 (for MMC V4.5, V4.51)	-
5	Revision 1.5 (for MMC V4.41)	-
4	Revision 1.4 (Obsolete)	-
3	Revision 1.3 (for MMC V4.3)	-
2	Revision 1.2 (for MMC V4.2)	-
1	Revision 1.1 (for MMC V4.1)	-
0	Revision 1.0 (for MMC V4.0)	-

[Table 6] High speed timing values (EXT_CSD register : HS_TIMING [185])

Value	Timing Interface	Supportability
0x0	Selecting backwards compatibility interface timing	Support
0x1	High Speed	Support
0x2	HS200	Support
0x3	HS400	Support

IF THERE IS ANY OTHER OPERATION TO IMPLEMENT IN ADDITION TO SPECIFICATION IN THE DATASHEET OR JEDEC STANDARD, PLEASE CONTACT EACH BRANCH OFFICE OR HEADQUARTERS OF SAMSUNG ELECTRONICS.

5.0 New eMMC5.1 Features

5.1 Overview

New Feature	JEDEC	Support
Cache Flushing Report	Mandatory	Yes
Background operation control	Mandatory	Yes
Command Queuing	Optional	Yes
Enhanced Strobe	Optional	Yes
RPMB Throughput improve	Optional	Yes
Secure Write Protection	Optional	Yes

5.2 Command Queuing

To facilitate command queuing in eMMC, the device manages an internal task queue that the host can queue during data transfer tasks.

Every task is issued by the host and initially queued as pending. The device works to prepare pending tasks for execution. When a task is ready for execution, its state changes to "ready for execution".

The host tracks the state of all queued tasks and may order the execution of any task, marked as "ready for execution", by sending a command indicating its task ID. The device executes the data transfer transaction after receiving the execute command(CMD46/CMD47)

5.2.1 CMD Set Description

[Table 7] CMD Set Description and Details

CMD	Type	Argument	Abbreviation	Purpose
CMD44	ac/R1	[31] Reliable Write Request [30] DAT_DIR - "0" write / "1" read [29] tag request [28:25] context ID [24] forced programming [23] Priority: "0" simple / "1" high [20:16] TASK ID [15:0] number of blocks	QUEUED_TASK_PARAMS	Define direction of operation (Read or Write) and Set high priority CMD Queue with task ID
CMD45	ac/R1	[31:0] Start block address	QUEUED_TASK_ADDRESS	Indicate data address for Queued CMD
CMD46	adtc/R1	[20:16] TASK ID	EXECUTE_READ_TASK	(Read) Transmit the requested number of data blocks
CMD47	adtc/R1	[20:16] TASK ID	EXECUTE_WRITE_TASK	(Write) Transmit the requested number of data blocks
CMD48	ac/R1b	[20:16] Task ID [3:0] TM op-code	CMDQ_TASK_MGMT	Reset a specific task or entire queue. [20:16] when TM op-code = 2h these bits represent TaskID. When TM op-code = 1h these bits are reserved."

5.2.2 New Response : QSR (Queue Status Register)

The 32-bit Queue Status Register (QSR) carries the state of tasks in the queue at a specific point in time. The host has read access to this register through device response to SEND_STATUS command (CMD13 with bit[15]="1"), R1's argument will be the 32-bit Queue Status Register (QSR). Every bit in the QSR represents the task whose ID corresponds to the bit index. If bit QSR[i] = "0", then the queued task with a Task ID i is not ready for execution. The task may be queued and pending, or the Task ID is unused. If bit QSR[i] = "1", then the queued task with Task ID i is ready for execution.

5.2.3 Send Status : CMD13

CMD13 for reading the Queue Status Register (QSR) by the host. If bit[15] in CMD13's argument is set to 1, then the device shall send an R1 Response with the QSR instead of the Device Status. * There is still legacy CMD13 with R` response

5.2.4 Mechanism of CMD Queue operation

Host issues CMD44 with Task ID number, Sector, Count, Direction, Priority to the device followed by CMD45 and host checks the Queue Status check with CMD13 [15]bits to 1. After that host issues CMD46 for Read or CMD47 for write During CMD queue operation, CMD44/CMD45 is able to be issued at anytime when the CMD line is not in use

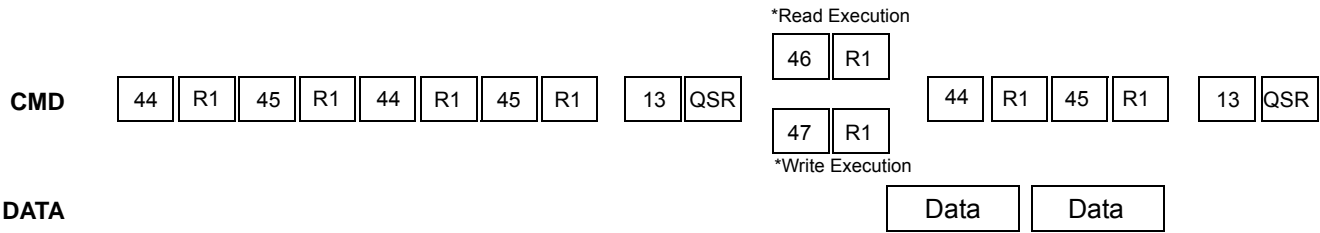

5.2.5 CMD Queue Register description

Configuration and capability structures shall be added to the EXT_CSD register, as described below

[Table 8] CMD Queuing Support (EXT_CSD register : CMDQ_SUPPORT [308])

Bit7	Bit6	Bit5	Bit4	Bit 3	Bit2	Bit1	Bit0
Reserved							CMD Queue supportability

This field indicates whether the device supports command queuing or not

- 0x0: CMD Queue function is not supported
- 0x1: CMD Queue function is supported

[Table 9] Command Queue Mode Enable(EXT_CSD register : CMDQ_MODE_EN [15])

Bit7	Bit6	Bit5	Bit4	Bit 3	Bit2	Bit1	Bit0
Reserved							0x00

This field is used by the host enable command queuing

- 0x0: Queue function is not enabled
- 0x1: Queue function is enabled

[Table 10] CMD Queuing Depth(EXT_CSD register : CMDQ_DEPTH [307])

Bit7	Bit6	Bit5	Bit4	Bit 3	Bit2	Bit1	Bit0
Reserved				0x0F			

This field is used to calculate the depth of the queue supported by the device

- Bit encoding:
- [7:5]: Reserved
- [4:0]: N,a parameter used to calculate the Queue Depth of task queue in the device.
Queue Depth = N+1.

5.3 Enhanced Strobe Mode

This product supports Enhanced Strobe in HS400 mode and refer to the details as described in eMMC5.1 JEDEC standard

5.4 RPMB Throughput improve

[Table 11] Related parameter register in EXT_CSD : WR_REL_PARAM [166]

Name	Field	Bit	Type
Enhanced RPMB Reliable Write	EN_RPMB_REL_WR	4	R

- Bit[4]: EN_RPMB_REL_WR(R)
- 0x0: RPMB transfer size is either 256B (single 512B frame) or 512B (Two 512B frame).
- 0 x1: RPMB transfer size is either 256B (single 512B frame), 512B (Two 512B frame), or 8KB(Thirthy two 512B frames).

IF THERE IS ANY OTHER OPERATION TO IMPLEMENT IN ADDITION TO SPECIFICATION IN THE DATASHEET OR JEDEC STANDARD, PLEASE CONTACT EACH BRANCH OFFICE OR HEADQUARTERS OF SAMSUNG ELECTRONICS.

5.5 Secure Write Protection

Configuration and capability structures shall be added to the EXT_CSD register and Authenticated Device Configuration Area as described below

[Table 12] Parameter register in EXT_CSD : SECURE_WP_INFO [211]

Bit7	Bit6	Bit5	Bit4	Bit	Bit2	Bit1	Bit0
Reserved						SECURE_WP_EN_STATUS	SECURE_WP_SUPPORT

Bit[7:2]: Reserved

Bit[1]: SECURE_WP_EN_STATUS(R)

0x0: Legacy Write Protection mode.

0x1: Secure Write Protection mode.

Bit[0]: SECURE_WP_SUPPORT(R)

0x0: Secure Write Protection is NOT supported by this device

0x1: Secure Write Protection is supported by this device

[Table 13] Authenticated Device Configuration Area[1] : SECURE_WP_MODE_ENABLE

Bit7	Bit6	Bit5	Bit4	Bit	Bit2	Bit1	Bit0
Reserved							0x00

Bit[7:1] : Reserved

Bit[0] : SECURE_WP_EN (R/W/E)

The default value of this field is 0x0.

- 0x0 : Legacy Write Protection mode, i.e., TMP_WRITE_PROTECT[12] , PERM_WRITE_PROTECT[13] is updated by CMD27. USER_WP[171], BOOT_WP[173] and BOOT_WP_STATUS[174] are updated by CMD6.
- 0x1 : Secure Write Protection mode. The access to the write protection related EXT_CSD and CSD fields depends on the value of SECURE_WP_MASK bit in SECURE_WP_MODE_CONFIG field.

[Table 14] Authenticated Device Configuration Area[2] : SECURE_WP_MODE_CONFIG

Bit7	Bit6	Bit5	Bit4	Bit	Bit2	Bit1	Bit0
Reserved							0x00

Bit[7:1] : Reserved

Bit[0] : SECURE_WP_MASK (R/W/E_P)

The default value of this field is 0x0.

- 0x0: Disabling updating WP related EXT_CSD and CSD fields. CMD27 (Program CSD) will generate generic error for setting TMP_WRITE_PROTECT[12] , PERM_WRITE_PROTECT[13]. CMD6 for updating USER_WP[171], BOOT_WP[173] and BOOT_WP_STATUS[174] generates SWITCH_ERROR. If a force erase command is issued, the command will fail (Device stays locked) and the LOCK_UNLOCK_FAILED error bit will be set in the status register. If CMD28 or CMD29 is issued, then generic error will be occurred. Power-on Write Protected boot partitions will keep protected mode after power failure, H/W reset assertion and any CMD0 reset. The device keeps the current value of BOOT_WP_STATUS in the EXT_CSD register to be same after power cycle, H/W reset assertion, and any CMD0 reset.
- 0x1: Enabling updating WP related EXT_CSD and CSD fields. I.e TMP_WRITE_PROTECT[12] , PERM_WRITE_PROTECT[13] , USER_WP[171], BOOT_WP[173] and BOOT_WP_STATUS[174] are accessed using CMD6, CMD8 and CMD27. If a force erase command is issued and accepted, then ALL THE DEVICE CONTENT WILL BE ERASED including the PWD and PWD_LEN register content and the locked Device will get unlocked. If a force erase command is issued and power-on protected or a permanently-write-protected write protect groups exist on the device, the command will fail (Device stays locked) and the LOCK_UNLOCK_FAILED error bit will be set in the status register. An attempt to force erase on an unlocked Device will fail and LOCK_UNLOCK_FAILED error bit will be set in the status register. Write Protection is applied to the WPG indicated by CMD28 with the WP type indicated by the bit[2] and bit[0] of USER_WP[171]. All temporary WP Groups and power-on Write Protected boot partitions become writable/erasable temporarily which means write protect type is not changed. All power-on and permanent WP Groups in user area will not become writable/erasable temporarily. Those temporarily writable/erasable area will become write protected when this bit is cleared to 0x0 by the host or when there is power failure, H/W reset assertion and any CMD0 reset. The device keeps the current value of BOOT_WP_STATUS in the EXT_CSD register to be same after power cycle, H/W reset assertion, and any CMD0 reset.

6.0 Technical Notes

6.1 S/W Algorithm

6.1.1 Partition Management

The device initially consists of two Boot Partitions and RPMB Partition and User Data Area.

The User Data Area can be divided into four General Purpose Area Partitions and User Data Area partition. Each of the General Purpose Area partitions and a section of User Data Area partition can be configured as enhanced partition.

6.1.1.1 Enhanced Partition (Area)

SAMSUNG eMMC adopts Enhanced User Data Area as SLC Mode. Therefore when master adopts some portion as enhanced user data area in User Data Area, that area occupies double size of original set up size. (ex> if master set 1MB for enhanced mode, total 2MB user data area is needed to generate 1MB enhanced area)

Max Enhanced User Data Area size is defined as (MAX_ENH_SIZE_MULT x HC_WP_GRP_SIZE x HC_ERASE_GRP_SIZE x 512kBytes)

6.1.2 Boot operation

Device supports not only boot mode but also alternative boot mode. Device supports high speed timing and dual data rate during boot.

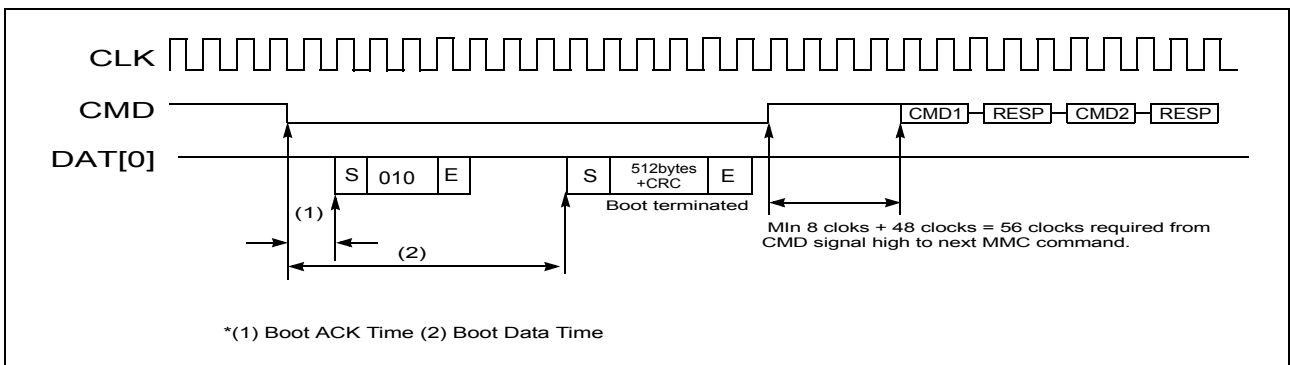

Figure 6. embedded MultiMediaCard state diagram (boot mode)

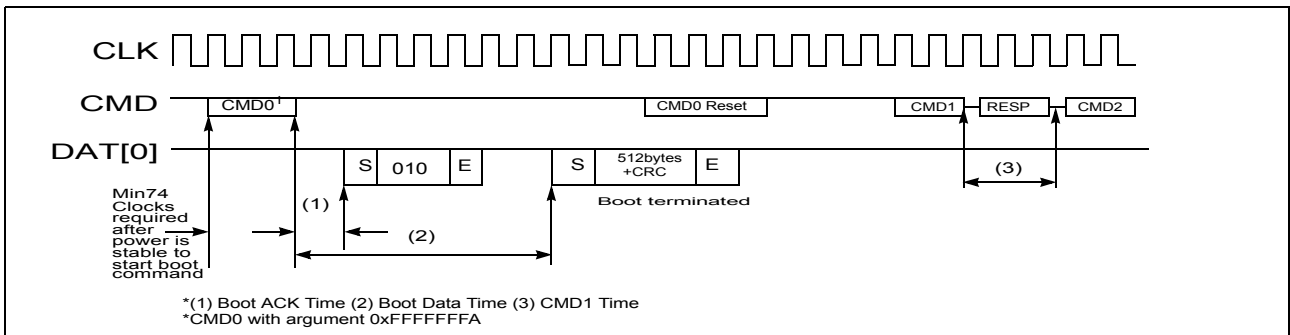

Figure 7. embedded MultiMediaCard state diagram (alternative boot mode)

[Table 15] Boot ack, boot data and initialization Time

Timing Factor	Value
(1) Boot ACK Time	< 50 ms
(2) Boot Data Time	< 100 ms
(3) Initialization Time ¹⁾	< 3 secs

NOTE:

1) This initialization time includes partition setting, Please refer to INI_TIMEOUT_AP in 6.4 Extended CSD Register.
 Normal initialization time (without partition setting) is completed within 1sec

6.1.3 User Density

Total User Density depends on device type.
 For example, 32MB in the SLC Mode requires 64MB in MLC.
 This results in decreasing of user density

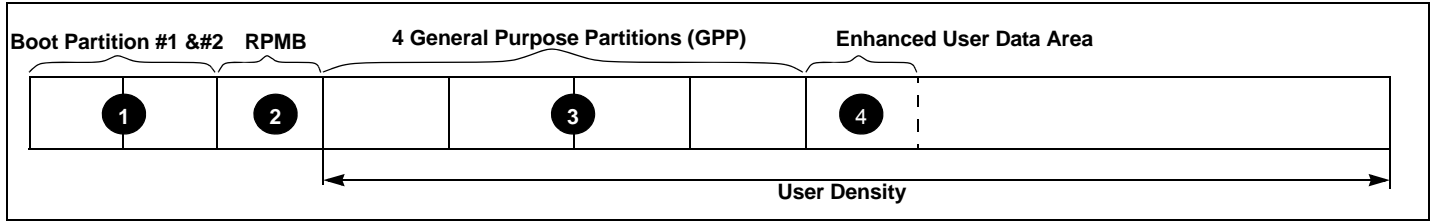

[Table 16] Capacity according to partition

		Boot partition 1	Boot partition 2	RPMB
8GB	Default.	4,096KB	4,096KB	512KB
	Max.	4,096KB	4,096KB	4,096KB
16GB/32GB/64GB	Default.	4,096KB	4,096KB	4,096KB
	Max.	4,096KB	4,096KB	4,096KB

[Table 17] Maximum Enhanced Partition Size

Device	Max. Enhanced Partition Size
8 GB	3,909,091,328 Byte
16 GB	7,809,794,048 Byte
32 GB	15,627,976,704 Byte
64 GB	31,264,342,016 Byte

[Table 18] User Density Size

Device	User Density Size
8 GB	7,818,182,656 Byte
16 GB	15,634,268,160 Byte
32 GB	31,268,536,320 Byte
64 GB	62,537,072,640 Byte

6.1.4 Auto Power Saving Mode

If host does not issue any command during a certain duration (1ms), after previously issued command is completed, the device enters "Power Saving mode" to reduce power consumption.

At this time, commands arriving at the device while it is in power saving mode will be serviced in normal fashion

[Table 19] Auto Power Saving Mode and exit

Mode	Enter Condition	Escape Condition
Auto Power Saving Mode	When previous operation which came from Host is completed and no command is issued during a certain time.	If Host issues any command

[Table 20] Auto Power Saving Mode and Sleep Mode

	Auto Power Saving Mode	Sleep Mode
NAND Power	ON	OFF
Goto Sleep Time	< 1ms	< 1ms

6.1.5 Performance

[Table 21] Performance

Density	Sequential Read (MB/s)	Sequential Write (MB/s)
8 GB	330	50
16 GB		100
32 GB		200
64 GB		

* Test Condition : Bus width x8, HS400, 512KB data transfer, w/o file system overhead, measured on Samsung's internal board

7.0 REGISTER VALUE

7.1 OCR Register

The 32-bit operation conditions register stores the V_{CCQ} voltage profile of the eMMC. In addition, this register includes a status information bit. This status bit is set if the eMMC power up procedure has been finished. The OCR register shall be implemented by all eMMCs.

[Table 22] OCR Register

OCR bit	VCCQ voltage window ²	Register Value
[6:0]	Reserved	00 00000b
[7]	1.70 - 1.95	1b
[14:8]	2.0-2.6	000 0000b
[23:15]	2.7-3.6	1 1111 1111b
[28:24]	Reserved	0 0000b
[30:29]	Access Mode	00b (byte mode) 10b (sector mode) -[*Higher than 2GB only]
[31]	eMMC power up status bit (busy) ¹	

NOTE :

- 1) This bit is set to LOW if the eMMC has not finished the power up routine
- 2) The voltage for internal flash memory(V_{CC}) should be 2.7-3.6v regardless of OCR Register value.

7.2 CID Register

[Table 23] CID Register

Name	Field	Width	CID-slice	CID Value
Manufacturer ID	MID	8	[127:120]	0x15
Reserved		6	[119:114]	---
Card/BGA	CBX	2	[113:112]	01
OEM/Application ID	OID	8	[111:104]	--- ¹
Product name	PNM	48	[103:56]	See Product name table
Product revision	PRV	8	[55:48]	--- ²
Product serial number	PSN	32	[47:16]	--- ³
Manufacturing date	MDT	8	[15:8]	--- ⁴
CRC7 checksum	CRC	7	[7:1]	--- ⁵
not used, always '1'	-	1	[0:0]	---

NOTE :

- 1),4),5) description are same as eMMC JEDEC standard
- 2) PRV is composed of the revision count of controller and the revision count of F/W patch
- 3) A 32 bits unsigned binary integer. (Random Number)

7.2.1 Product name table (In CID Register)

[Table 24] Product name table

Part Number	Density	Product Name in CID Register (PNM)
KLM8G1GETF-B041	8 GB	0 x 384754463452
KLMAG1JETD-B041	16 GB	0 x 414A54443452
KLMBG2JETD-B041	32 GB	0 x 424A54443452
KLMCG4JETD-B041	64 GB	0 x 434A54443452

7.3 CSD Register

The Card-Specific Data register provides information on how to access the eMMC contents. The CSD defines the data format, error correction type, maximum data access time, data transfer speed, whether the DSR register can be used etc. The programmable part of the register (entries marked by W or E, see below) can be changed by CMD27. The type of the entries in the table below is coded as follows:

R: Read only

W: One time programmable and not readable.

R/W: One time programmable and readable.

W/E: Multiple writable with value kept after power failure, H/W reset assertion and any CMD0 reset and not readable.

R/W/E: Multiple writable with value kept after power failure, H/W reset assertion and any CMD0 reset and readable.

R/W/C_P: Writable after value cleared by power failure and H/W reset assertion (the value not cleared by CMD0 reset) and readable.

R/W/E_P: Multiple writable with value reset after power failure, H/W reset assertion and any CMD0 reset and readable.

W/E/_P: Multiple writable with value reset after power failure, H/W reset assertion and any CMD0 reset and not readable.

[Table 25] CSD Register

Name	Field	Width	Cell Type	CSD-slice	CSD Value			
					8GB	16 GB	32 GB	64 GB
CSD structure	CSD_STRUCTURE	2	R	[127:126]	0x03			
System specification version	SPEC_VERS	4	R	[125:122]	0x04			
Reserved	-	2	R	[121:120]	-			
Data read access-time 1	TAAC	8	R	[119:112]	0x27			
Data read access-time 2 in CLK cycles (NSAC*100)	NSAC	8	R	[111:104]	0x01			
Max. bus clock frequency	TRAN_SPEED	8	R	[103:96]	0x32			
Device command classes	CCC	12	R	[95:84]	0xF5			
Max. read data block length	READ_BL_LEN	4	R	[83:80]	0x09			
Partial blocks for read allowed	READ_BL_PARTIAL	1	R	[79:79]	0x00			
Write block misalignment	WRITE_BLK_MISALIGN	1	R	[78:78]	0x00			
Read block misalignment	READ_BLK_MISALIGN	1	R	[77:77]	0x00			
DSR implemented	DSR_IMP	1	R	[76:76]	0x00			
Reserved	-	2	R	[75:74]	-			
Device size	C_SIZE	12	R	[73:62]	0xFFF			
Max. read current @ VDD min	VDD_R_CURR_MIN	3	R	[61:59]	0x06			
Max. read current @ VDD max	VDD_R_CURR_MAX	3	R	[58:56]	0x06			
Max. write current @ VDD min	VDD_W_CURR_MIN	3	R	[55:53]	0x06			
Max. write current @ VDD max	VDD_W_CURR_MAX	3	R	[52:50]	0x06			
Device size multiplier	C_SIZE_MULT	3	R	[49:47]	0x07			
Erase group size	ERASE_GRP_SIZE	5	R	[46:42]	0x1F			
Erase group size multiplier	ERASE_GRP_MULT	5	R	[41:37]	0x1F			
Write protect group size	WP_GRP_SIZE	5	R	[36:32]	0x0F			
Write protect group enable	WP_GRP_ENABLE	1	R	[31:31]	0x01			
Manufacturer default ECC	DEFAULT_ECC	2	R	[30:29]	0x00			
Write speed factor	R2W_FACTOR	3	R	[28:26]	0x03			
Max. write data block length	WRITE_BL_LEN	4	R	[25:22]	0x09			
Partial blocks for write allowed	WRITE_BL_PARTIAL	1	R	[21:21]	0x00			
Reserved	-	4	R	[20:17]	-			
Content protection application	CONTENT_PROT_APP	1	R	[16:16]	0x00			
File format group	FILE_FORMAT_GRP	1	R/W	[15:15]	0x00			
Copy flag (OTP)	COPY	1	R/W	[14:14]	0x01			
Permanent write protection	PERM_WRITE_PROTECT	1	R/W	[13:13]	0x00			
Temporary write protection	TMP_WRITE_PROTECT	1	R/W/E	[12:12]	0x00			
File format	FILE_FORMAT	2	R/W	[11:10]	0x00			
ECC code	ECC	2	R/W/E	[9:8]	0x00			
CRC	CRC	7	R/W/E	[7:1]	-			
Not used, always '1'	-	1	—	[0:0]	-			

IF THERE IS ANY OTHER OPERATION TO IMPLEMENT IN ADDITION TO SPECIFICATION IN THE DATASHEET OR JEDEC STANDARD, PLEASE CONTACT EACH BRANCH OFFICE OR HEADQUARTERS OF SAMSUNG ELECTRONICS.

7.4 Extended CSD Register

The Extended CSD register defines the eMMC properties and selected modes. It is 512 bytes long.

The most significant 320 bytes are the Properties segment, which defines the eMMC capabilities and cannot be modified by the host. The lower 192 bytes are the Modes segment, which defines the configuration the eMMC is working in. These modes can be changed by the host by means of the SWITCH command.

R: Read only

W: One time programmable and not readable.

R/W: One time programmable and readable.

W/E: Multiple writable with value kept after power failure, H/W reset assertion and any CMD0 reset and not readable.

R/W/E: Multiple writable with value kept after power failure, H/W reset assertion and any CMD0 reset and readable.

R/W/C_P: Writable after value cleared by power failure and HW/ rest assertion (the value not cleared by CMD0 reset) and readable.

R/W/E_P: Multiple writable with value reset after power failure, H/W reset assertion and any CMD0 reset and readable.

W/E/_P: Multiple writable with value reset after power failure, H/W reset assertion and any CMD0 reset and not readable

[Table 26] Extended CSD Register

Name	Field	Size (Bytes)	Cell Type	CSD slice	CSD Value			
					8GB	16GB	32GB	64GB
Properties Segment								
Reserved ¹		6	-	[511:506]	-			
Extended Security Commands Error	EXT_SECURITY_ERR	1	R	[505]	0x00			
Supported Command Sets	S_CMD_SET	1	R	[504]	0x01			
HPI features	HPI_FEATURES	1	R	[503]	0x01			
Background operations support	BKOPS_SUPPORT	1	R	[502]	0x01			
Max packed read commands	MAX_PACKED_READS	1	R	[501]	0x3F			
Max packed write commands	MAX_PACKED_WRITES	1	R	[500]	0x3F			
Data Tag Support	DATA_TAG_SUPPORT	1	R	[499]	0x01			
Tag Unit Size	TAG_UNIT_SIZE	1	R	[498]	0x02			
Tag Resources Size	TAG_RES_SIZE	1	R	[497]	0x00			
Context management capabilities	CONTEXT_CAPABILITIES	1	R	[496]	0x05			
Large Unit size	LARGE_UNIT_SIZE_M1	1	R	[495]	0x07			
Extended partitions attribute support	EXT_SUPPORT	1	R	[494]	0x03			
Supported modes	SUPPORTED_MODES	1	R	[493]	0x03			
FFU features	FFU_FEATURES	1	R	[492]	0x00			
Operation codes timeout	OPERATION_CODE_TIMEOUT	1	R	[491]	0x00			
FFU Argument	FFU_ARG	4	R	[490:487]	0xC7810000			
Barrier support	BARRIER_SUPPORT	1	R	[486]	0x00			
Reserved ¹		177	-	[485:309]	-			
CMD Queuing Support	CMDQ_SUPPORT	1	R	[308]	0x01			
CMD Queuing Depth	CMDQ_DEPTH	1	R	[307]	0x0F			
Reserved ¹		1	-	[306:270]	-			
Number of FW sectors correctly programmed	NUMBER_OF_FW_SECTORS_CORRECTLY_PROGRAMMED	4	R	[269]	0x01			
Vendor proprietary health report	VENDOR_PROPRIETARY_HEALTH_REPORT	32	R	[268]	0x01			
Device life time estimation type B	DEVICE_LIFE_TIME_EST_TYP_B	1	R	[267]	0x01			
Device life time estimation type A	DEVICE_LIFE_TIME_EST_TYP_A	1	R	[266]	0x00			
Pre EOL information	PRE_EOL_INFO	1	R	[265]	0x08	0x10	0x20	
Optimal read size	OPTIMAL_READ_SIZE	1	R	[264]	0x01			
Optimal write size	OPTIMAL_WRITE_SIZE	1	R	[263:262]	0x00			
Firmware version	FIRMWARE_VERSION	3	R	[261:254]	0x01			

IF THERE IS ANY OTHER OPERATION TO IMPLEMENT IN ADDITION TO SPECIFICATION IN THE DATASHEET OR JEDEC STANDARD, PLEASE CONTACT EACH BRANCH OFFICE OR HEADQUARTERS OF SAMSUNG ELECTRONICS.

Power class for 200MHz, DDR at VCC=3.6V	PWR_CL_DDR_200_360	1	R	[253]	0x00			
Cache size	CACHE_SIZE	4	R	[252:249]	0x10000			
Generic CMD6 timeout	GENERIC_CMD6_TIME	1	R	[248]	0x0A			
Power off notification (long) timeout	POWER_OFF_LONG_TIME	1	R	[247]	0x3C			
Background operations status	BKOPS_STATUS	1	R	[246]	0x00			
Number of correctly programmed sectors	CORRECTLY_PRG_SECTORS_NUM	4	R	[245:242]	0x00			
1st initialization time after partitioning	INI_TIMEOUT_AP	1	R	[241]	0x1E			
Cache flush policy	CACHE_FLUSH_POLICY	1	R	[240]	-			
Power class for 52MHz, DDR at 3.6V	PWR_CL_DDR_52_360	1	R	[239]	0x00			
Power class for 52MHz, DDR at 1.95V	PWR_CL_DDR_52_195	1	R	[238]	0x00			
Power class for 200MHz at V _{CCQ} =1.95V, V _{CC} =3.6V	PWR_CL_200_360	1	R	[237]	0x00			
Power class for 200MHz, at V _{CCQ} =1.3V, V _{CC} =3.6V	PWR_CL_200_195	1	R	[236]	0x00			
Minimum Write Performance for 8bit at 52MHz in DDR mode	MIN_PERF_DDR_W_8_52	1	R	[235]	0x00			
Minimum Read Performance for 8bit at 52MHz in DDR mode	MIN_PERF_DDR_R_8_52	1	R	[234]	0x00			
Reserved ¹		1	-	[233]	-			
TRIM Multiplier	TRIM_MULT	1	R	[232]	0x02			
Secure Feature support	SEC_FEATURE_SUPPORT	1	R	[231]	0x55			
Secure Erase Multiplier	SEC_ERASE_MULT	1	R	[230]	0x1B			
Secure TRIM Multiplier	SEC_TRIM_MULT	1	R	[229]	0x11			
Boot information	BOOT_INFO	1	R	[228]	0x07			
Reserved ¹		1	-	[227]	-			
Boot partition size	BOOT_SIZE_MULT	1	R	[226]	0x20			
Access size	ACC_SIZE	1	R	[225]	0x07			
High-capacity erase unit size	HC_ERASE_GRP_SIZE	1	R	[224]	0x01			
High-capacity erase timeout	ERASE_TIMEOUT_MULT	1	R	[223]	0x01			
Reliable write sector count	REL_WR_SEC_C	1	R	[222]	0x01			
High-capacity write protect group size	HC_WP_GRP_SIZE	1	R	[221]	0x10			
Sleep current (V _{CC})	S_C_VCC	1	R	[220]	0x07			
Sleep current (V _{CCQ})	S_C_VCCQ	1	R	[219]	0x07			
Production state awareness timeout	PRODUCTION_STATE_AWARENESS_TIMEOUT	1	R	[218]	0x00			
Sleep/awake timeout	S_A_TIMEOUT	1	R	[217]	0x11			
Sleep Notification Timeout	SLEEP_NOTIFICATION_TIME	1	R	[216]	0x07			
Sector Count	SEC_COUNT	4	R	[215:212]	0xE90000	0x1D1F00	0x3A3E00	0x747C00
Secure Write Protect Information	SECURE_WP_INFO	1	R	[211]	0x01			
Minimum Write Performance for 8bit at 52MHz	MIN_PERF_W_8_52	1	R	[210]	0x00			
Minimum Read Performance for 8bit at 52MHz	MIN_PERF_R_8_52	1	R	[209]	0x00			
Minimum Write Performance for 8bit at 26MHz, for 4bit at 52MHz	MIN_PERF_W_8_26_4_52	1	R	[208]	0x00			
Minimum Read Performance for 8bit at 26MHz, for 4bit at 52MHz	MIN_PERF_R_8_26_4_52	1	R	[207]	0x00			
Minimum Write Performance for 4bit at 26MHz	MIN_PERF_W_4_26	1	R	[206]	0x00			

IF THERE IS ANY OTHER OPERATION TO IMPLEMENT IN ADDITION TO SPECIFICATION IN THE DATASHEET OR JEDEC STANDARD, PLEASE CONTACT EACH BRANCH OFFICE OR HEADQUARTERS OF SAMSUNG ELECTRONICS.

Minimum Read Performance for 4bit at 26MHz	MIN_PERF_R_4_26	1	R	[205]	0x00	
Reserved ¹		1	-	[204]	-	
Power class for 26MHz at 3.6V 1 R	PWR_CL_26_360	1	R	[203]	0x00	
Power class for 52MHz at 3.6V 1 R	PWR_CL_52_360	1	R	[202]	0x00	
Power class for 26MHz at 1.95V 1 R	PWR_CL_26_195	1	R	[201]	0x00	
Power class for 52MHz at 1.95V 1 R	PWR_CL_52_195	1	R	[200]	0x00	
Partition switching timing	PARTITION_SWITCH_TIME	1	R	[199]	0x02	
Out-of-interrupt busy timing	OUT_OF_INTERRUPT_TIME	1	R	[198]	0x0A	
I/O Driver Strength	DRIVER_STRENGTH	1	R	[197]	0x1F	
Device type	DEVICE_TYPE	1	R	[196]	0x57	
Reserved ¹		1	-	[195]	-	
CSD structure	CSD_STRUCTURE	1	R	[194]	0x02	
Reserved ¹		1	-	[193]	-	
Extended CSD revision	EXT_CSD_REV	1	R	[192]	0x08	
Modes Segment						
Command set	CMD_SET	1	R/W/E_P	[191]	0x00	
Reserved ¹		1	-	[190]	-	
Command set revision	CMD_SET_REV	1	R	[189]	0x00	
Reserved ¹		1	-	[188]	-	
Power class	POWER_CLASS	1	R/W/E_P	[187]	0x00	
Reserved ¹		1	-	[186]	-	
High-speed interface timing	HS_TIMING	1	R/W/E_P	[185]	0x01	0x00
Strobe Support	STROBE_SUPPORT	1	R	[184]	0x01	
Bus width mode	BUS_WIDTH	1	W/E_P	[183]	0x00	
Reserved ¹		1	-	[182]	-	
Erased memory content	ERASED_MEM_CONT	1	R	[181]	0x00	
Reserved ¹		1	-	[180]	-	
Partition configuration	PARTITION_CONFIG	1	R/W/E & R/W/E_P	[179]	0x00	
Boot config protection	BOOT_CONFIG_PROT	1	R/W & R/W/C_P	[178]	0x00	
Boot bus Conditions	BOOT_BUS_CONDITIONS	1	R/W/E	[177]	0x0	
Reserved ¹		1	-	[176]	-	
High-density erase group definition	ERASE_GROUP_DEF	1	R/W/E_P	[175]	0x00	
Boot write protection status registers	BOOT_WP_STATUS	1	R	[174]	0x00	
Boot area write protection register	BOOT_WP	1	R/W & R/W/C_P	[173]	0x00	
Reserved ¹		1	-	[172]	-	
User area write protection register	USER_WP	1	R/W, R/W/C_P & R/W/E_P	[171]	0x00	
Reserved ¹		1	-	[170]	-	
FW configuration	FW_CONFIG	1	R/W	[169]	0x00	
RPMB Size	RPMB_SIZE_MULT	1	R	[168]	0x04	0x20
Write reliability setting register	WR_REL_SET	1	R/W	[167]	0x1F	
Write reliability parameter register	WR_REL_PARAM	1	R	[166]	0x14	
Start Sanitize operation	SANITIZE_START	1	W/E_P	[165]	0x00	
Manually start background operations	BKOPS_START	1	W/E_P	[164]	0x00	

IF THERE IS ANY OTHER OPERATION TO IMPLEMENT IN ADDITION TO SPECIFICATION IN THE DATASHEET OR JEDEC STANDARD, PLEASE CONTACT EACH BRANCH OFFICE OR HEADQUARTERS OF SAMSUNG ELECTRONICS.

datasheet

eMMC

Enable background operations handshake	BKOPS_EN	1	R/W&R/W/E	[163]	0x00			
H/W reset function	RST_n_FUNCTION	1	R/W	[162]	0x00			
HPI management	HPI_MGMT	1	R/W/E_P	[161]	0x00			
Partitioning Support	PARTITIONING_SUPPORT	1	R	[160]	0x07			
Max Enhanced Area Size	MAX_ENH_SIZE_MULT	3	R	[159:157]	0x1D2	0x3A3	0x747	0xE8F
Partitions attribute	PARTITIONS_ATTRIBUTE	1	R/W	[156]	0x00			
Partitioning Setting	PARTITION_SETTING_COMPLETED	1	R/W	[155]	0x00			
General Purpose Partition Size	GP_SIZE_MULT	12	R/W	[154:143]	0x00			
Enhanced User Data Area Size	ENH_SIZE_MULT	3	R/W	[142:140]	0x00			
Enhanced User Data Start Address	ENH_START_ADDR	4	R/W	[139:136]	0x00			
Reserved ¹		1	-	[135]	-			
Bad Block Management mode	SEC_BAD_BLK_MGMNT	1	R/W	[134]	0x00			
Production state awareness	PRODUCTION_STATE_AWARENESS	1	W/E_P	[133]	0x00			
Package Case Temperature is controlled	TCASE_SUPPORT	1	W/E_P	[132]	0x00			
Periodic Wake-up	PERIODIC_WAKEUP	1	R/W/E	[131]	0x00			
Program CID/CSD in DDR mode support	PROGRAM_CID_CSD_DDR_SUPPORT	1	R	[130]	0x01			
Reserved ¹		2	-	[129:128]	-			
Vendor Specific Fields	VENDOR_SPECIFIC_FIELD	64	<ven-dor spe-cific>	[127:64]	-			
Native sector size	NATIVE_SECTOR_SIZE	1	R	[63]	0x00			
Sector size emulation	USE_NATIVE_SECTOR	1	R/W	[62]	0x00			
Sector size	DATA_SECTOR_SIZE	1	R	[61]	0x00			
1st initialization after disabling sector size emulation	INI_TIMEOUT_EMU	1	R	[60]	0x00			
Class 6 commands control	CLASS_6_CTRL	1	R/W/E_P	[59]	0x00			
Number of addressed group to be Released	DYNCAP_NEEDED	1	R	[58]	0x00			
Exception events control	EXCEPTION_EVENTS_CTRL	2	R/W/E_P	[57:56]	0x00			
Exception events status	EXCEPTION_EVENTS_STATUS	2	R	[55:54]	0x00			
Extended Partitions Attribute	EXT_PARTITIONS_ATTRIBUTE	2	R/W	[53:52]	0x00			
Context configuration	CONTEXT_CONF	15	R/W/E_P	[51:37]	0x00			
Packed command status	PACKED_COMMAND_STATUS	1	R	[36]	0x00			
Packed command failure index	PACKED_FAILURE_INDEX	1	R	[35]	0x00			
Power Off Notification	POWER_OFF_NOTIFICATION	1	R/W/E_P	[34]	0x00			
Control to turn the Cache ON/OFF	CACHE_CTRL	1	R/W/E_P	[33]	0x00			
Flushing of the cache	FLUSH_CACHE	1	W/E_P	[32]	0x00			
Control to turn the Barrier ON/OFF	BARRIER_CTRL	1	R	[31]	0x00			
Mode config	MODE_CONFIG	1	R/W/E_P	[30]	0x00			
Mode operation codes	MODE_OPERATION_CODES	1	W/E_P	[29]	0x00			
Reserved ¹		2	-	[28:27]	-			
FFU status	FFU_STATUS	1	R	[26]	0x00			
Pre loading data size	PRE_LOADING_DATA_SIZE	4	R/W/E_P	[25:22]	0x00			
Max pre loading data size	MAX_PRE_LOADING_DATA_SIZE	4	R	[21:18]	0x00			

IF THERE IS ANY OTHER OPERATION TO IMPLEMENT IN ADDITION TO SPECIFICATION IN THE DATASHEET OR JEDEC STANDARD, PLEASE CONTACT EACH BRANCH OFFICE OR HEADQUARTERS OF SAMSUNG ELECTRONICS.

Product state awareness enablement	PRODUCT_STATE_AWARENESS_ENABLEMENT	1	R/W/E & R	[17]	0x00
Secure Removal Type	SECURE_REMOVAL_TYPE	1	R/W & R	[16]	0x39
Command Queue Mode Enable	CMDQ_MODE_EN	1	R/W/E_P	[15]	0x00
Reserved ¹		15	-	[14:0]	-

NOTE :

1) Reserved bits should be read as "0."

8.0 AC PARAMETER

8.1 Timing Parameter

[Table 27] Timing Parameter

Timing Parameter		Max. Value	Unit
Initialization Time (tINIT)	Normal ¹⁾	1	s
	After partition setting ²⁾	3	s
Read Timeout		100	ms
Write Timeout		350	ms
Erase Timeout		20	ms
Force Erase Timeout		3	min
Secure Erase Timeout		8	s
Secure Trim step1 Timeout		5	s
Secure Trim step2 Timeout		3	s
Trim Timeout		600	ms
Partition Switching Timeout (after Init)		1	ms
Power Off Notification (Short) Timeout		100	ms
Power Off Notification (Long) Timeout		600	ms

- NOTE:**
- 1) Normal Initialization Time without partition setting
 - 2) Initialization Time after partition setting, refer to INI_TIMEOUT_AP in Chapter 7.4 EXT_CSD register
 - 3) Be advised Timeout Values specified in Table above are for testing purposes under Samsung test pattern only and actual timeout situations may vary
 - 4) EXCEPTION_EVENT may occur and the actual timeout values may vary due to user environment

8.2 Previous Bus Timing Parameters for DDR52 and HS200 mode are defined by JEDEC standard

8.3 Bus Timing Specification in HS400 mode

8.3.1 HS400 Device Input Timing

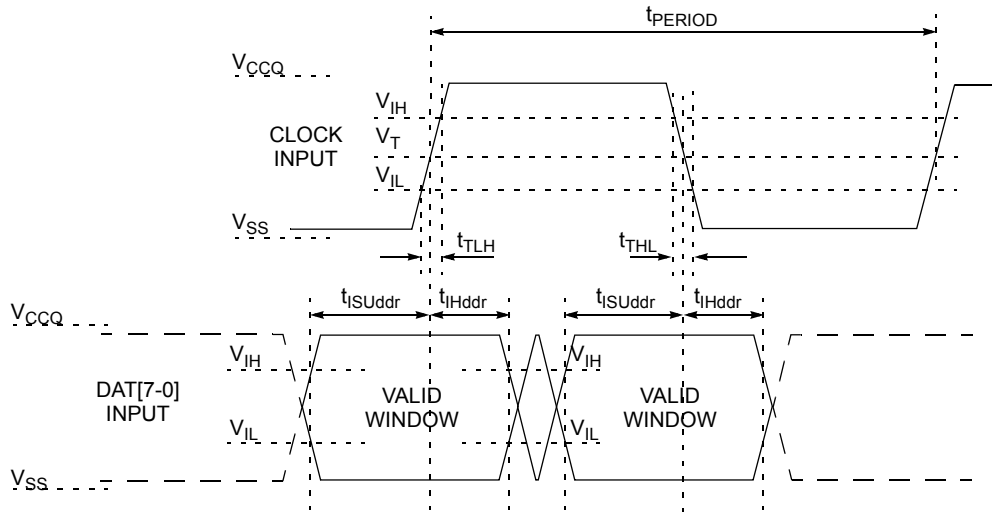

Figure 8. HS400 Device Input Timing

NOTE:

- 1) t_{ISU} and t_{IH} are measured at $V_{IL(max)}$ and $V_{IH(min)}$.
- 2) V_{IH} denotes $V_{IH(min)}$ and V_{IL} denotes $V_{IL(max)}$.

[Table 28] HS400 Device input timing

Parameter	Symbol	Min	Max	Unit
Input CLK				
Cycle time data transfer mode	t_{PERIOD}	5		ns
Slew rate	SR	1.125		V/ns
Duty cycle distortion	t_{CKDCD}	0.0	0.3	ns
Minimum pulse width	t_{CKMPW}	2.2		ns
Input DAT (referenced to CLK)				
Input set-up time	t_{ISUddr}	0.4		ns
Input hold time	t_{IHddr}	0.4		ns
Slew rate	SR	1.125		V/ns

8.3.2 HS400 Device Output Timing

Data Strobe is used to read data (data read and CRC status response read) in HS400 mode.
 The device output value of Data Strobe is "High-Z" when the device is not in outputting data (data read, CRC status response).
 Data Strobe is toggled only during data read period.

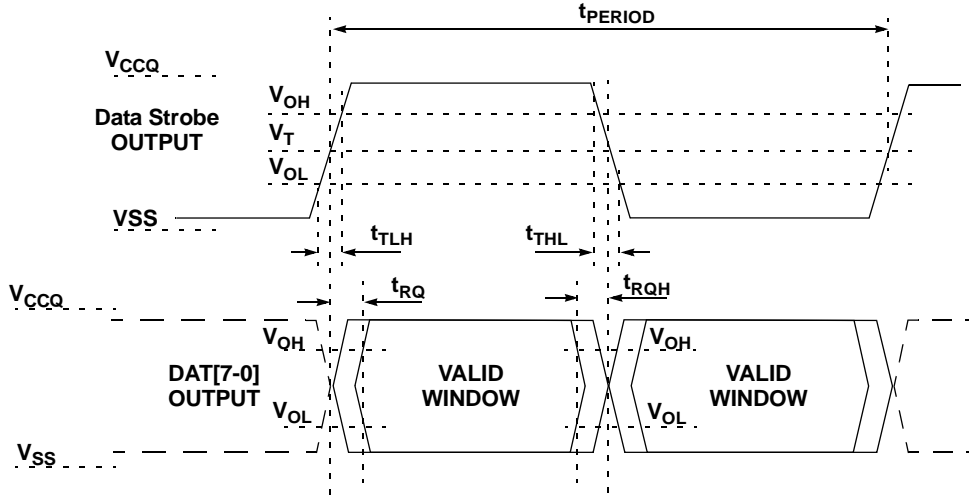

Figure 9. HS400 Device Output Timing

NOTE:
 V_{OH} denotes V_{OH(min.)} and V_{OL} denotes V_{OL(max.)}.

HS400 Device Output timing

Parameter	Symbol	Min	Max	Unit
Data Strobe				
Cycle time data transfer mode	t _{PERIOD}	5		ns
Slew rate	SR	1.125		V/ns
Duty cycle distortion	t _{DSDCD}	0.0	0.2	ns
Minimum pulse width	t _{DMPW}	2.0		ns
Read pre-amble	t _{RPRE}	0.4	-	t _{PERIOD}
Read post-amble	t _{RPST}	0.4	-	t _{PERIOD}
Output DAT (referenced to Data Strobe)				
Output skew	t _{RQ}	-	0.4	ns
Output hold skew	t _{RQH}	-	0.4	ns
Slew rate	SR	1.125		V/ns

IF THERE IS ANY OTHER OPERATION TO IMPLEMENT IN ADDITION TO SPECIFICATION IN THE DATASHEET OR JEDEC STANDARD, PLEASE CONTACT EACH BRANCH OFFICE OR HEADQUARTERS OF SAMSUNG ELECTRONICS.

8.4 Bus signal levels

As the bus can be supplied with a variable supply voltage, all signal levels are related to the supply voltage.

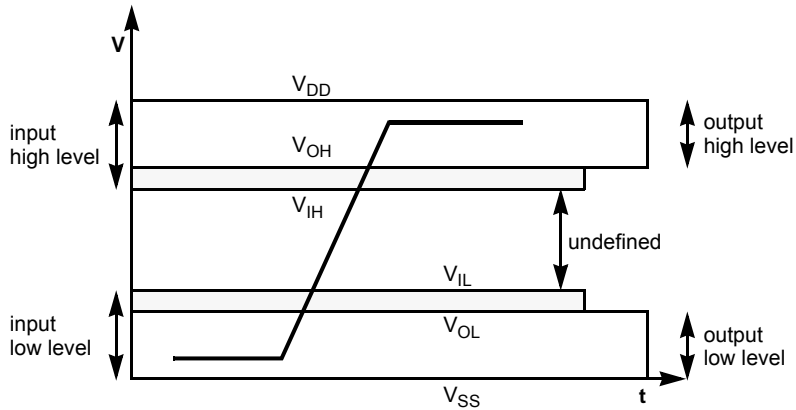

8.4.1 Open-drain mode bus signal level

[Table 29] Open-drain bus signal level

Parameter	Symbol	Min	Max.	Unit	Conditions
Output HIGH voltage	V_{OH}	$V_{DD} - 0.2$	-	V	1)
Output LOW voltage	V_{OL}	-	0.3	V	$I_{OL} = 2 \text{ mA}$

NOTE:

1) Because V_{oh} depends on external resistance value (including outside the package), this value does not apply as device specification. Host is responsible to choose the external pull-up and open drain resistance value to meet V_{oh} Min value.

8.4.2 Push-pull mode bus signal level eMMC

The device input and output voltages shall be within the following specified ranges for any V_{CCQ} of the allowed voltage range

[Table 30] Push-pull signal level—high-voltage eMMC

Parameter	Symbol	Min	Max.	Unit	Conditions
Output HIGH voltage	V_{OH}	$0.75 \cdot V_{DD}$	-	V	$I_{OH} = -100 \text{ uA} @ V_{CCQ} \text{ min}$
Output LOW voltage	V_{OL}	-	$0.125 \cdot V_{DD}$	V	$I_{OL} = 100 \text{ uA} @ V_{CCQ} \text{ min}$
Input HIGH voltage	V_{IH}	$0.625 \cdot V_{DD}$	$V_{DD} + 0.3$	V	-
Input LOW voltage	V_{IL}	$V_{SS} - 0.3$	$0.25 \cdot V_{DD}$	V	-

[Table 31] Push-pull signal level—1.70 - 1.95 V_{CCQ} voltage Range

Parameter	Symbol	Min	Max.	Unit	Conditions
Output HIGH voltage	V_{OH}	$V_{CCQ} - 0.45V$	-	V	$I_{OH} = -2mA$
Output LOW voltage	V_{OL}	-	0.45V	V	$I_{OL} = 2mA$
Input HIGH voltage	V_{IH}	$0.65 \cdot V_{CCQ}^{1)}$	$V_{CCQ} + 0.3$	V	-
Input LOW voltage	V_{IL}	$V_{SS} - 0.3$	$0.35 \cdot V_{CCQ}^{2)}$	V	-

NOTE:

1) $0.7 \cdot V_{CCQ}$ for MMC4.3 and older revisions.
 2) $0.3 \cdot V_{CCQ}$ for MMC4.3 and older revisions.

9.0 DC PARAMETER

9.1 Active Power Consumption during operation

[Table 32] Active Power Consumption during operation

Density	NAND Type	V _{CCQ}	V _{CC}	Unit
8 GB	64Gb x 1	180	50	mA
16 GB	128Gb x 1		100	
32 GB	128Gb x 2			
64 GB	128Gb x 4		200	

* Power Measurement conditions: Bus configuration =x8 @HS400

* The measurement for max RMS current is the average RMS current consumption over a period of 100ms

9.2 Standby Power Consumption in auto power saving mode and standby state.

[Table 33] Standby Power Consumption in auto power saving mode and standby state

Density	NAND Type	V _{CCQ}	V _{CC}	V _{CCQ}	V _{CC}	Unit
		25°C(Typ)	85°C	25°C(Typ)	85°C	
8 GB	64Gb x 1	120	400	40	85	uA
16 GB	128Gb x 1			50	135	
32 GB	128Gb x 2					
64 GB	128Gb x 4			70	235	

NOTE:

Power Measurement conditions: Bus configuration =x8, No CLK

*Typical value is measured at V_{CC}=3.3V, TA=25°C. Not 100% tested.

9.3 Sleep Power Consumption in Sleep State

[Table 34] Sleep Power Consumption in Sleep State

Density	NAND Type	V _{CCQ}		V _{CC}	Unit
		25°C(Typ)	85°C		
8 GB	64Gb x 1	120	400	0 ¹⁾	uA
16 GB	128Gb x 1				
32 GB	128Gb x 2				
64 GB	128Gb x 4				

NOTE:

Power Measurement conditions: Bus configuration =x8, No CLK

1) In auto power saving mode, V_{CC} power can not be turned off. However in sleep mode V_{CC} power can be turned off.

9.4 Supply Voltage

[Table 35] Supply voltage

Item	Min	Max	Unit
V _{CCQ}	1.70	1.95	V
V _{CC}	2.7	3.6	V
V _{SS}	-0.5	0.5	V

9.5 Bus Signal Line Load

The total capacitance C_L of each line of the eMMC bus is the sum of the bus master capacitance C_{HOST} , the bus capacitance C_{BUS} itself and the capacitance C_{DEVICE} of the eMMC connected to this line:

$$C_L = C_{HOST} + C_{BUS} + C_{DEVICE}$$

The sum of the host and bus capacitances should be under 20pF.

[Table 36] Bus Signal Line Load

sParameter	Symbol	Min	Typ.	Max	Unit	Remark
Pull-up resistance for CMD	R_{CMD}	4.7		100	KOhm	to prevent bus floating
Pull-up resistance for DAT0-DAT7	R_{DAT}	10		100	KOhm	to prevent bus floating
Internal pull up resistance DAT1-DAT7	R_{int}	10		150	KOhm	to prevent unconnected lines floating
Single Device capacitance	C_{DEVICE}			12	pF	
Maximum signal line inductance				16	nH	$f_{PP} \leq 52$ MHz

[Table 37] Capacitance and Resistance for HS400 mode

Parameter	Symbol	Min	Typ	Max	Unit	Remark
Bus signal line capacitance	C_L			13	pF	Single Device
Single Device capacitance	C_{DEVICE}			6	pF	
Pull-down resistance for Data Strobe	$R_{Data\ Strobe}$	10		100	KOhm	

X-ON Electronics

Largest Supplier of Electrical and Electronic Components

Click to view similar products for eMMC category:

Click to view products by SAMSUNG manufacturer:

Other Similar products are found below :

[SDINBDG4-8G-ZA2](#) [S40FC004C1B2I00300](#) [FEMDRW128G-88A19](#) [ZDEMDCM064G-95A8](#) [KLM8G1GEUF-B04P](#) [FEMDNN016G-A3A55](#) [FEMDMW016G-88A43](#) [FEMDMW064G-88A19](#) [FEMDRW016G-88A43](#) [FEMDME064G-A8A58](#) [FEMDNN016G-58A43](#) [THGAMRG7T13BAIL](#) [KLM8G1GETF-B041006](#) [KLMCG2UCTB-B041](#) [KLMCG2UCTA-B041](#) [KLMCG4JEUD-B04Q](#) [H26M41208HPRA](#) [H26M51002KPR](#) [ZDEMMC16GA](#) [FEMDME032G-A8A58](#) [THGAMRG8T13BAIL](#) [SDINBDV4-32G](#) [SDDDC4DR-64G](#) [SDADA4DR-64G](#) [FEMDME004G-A8A39](#) [SDINBDG4-16G](#) [SDINBDG4-8G](#) [SDINBDG4-8G-XI1](#) [SDINBDG4-8G-I1](#) [SDINBDG4-16G-I1](#) [SDINADF4-16G-H](#) [SDINBDG4-32G](#) [SDINBDG4-8G-ZA](#) [SDINBDG4-64G-I1](#) [SFEM032GB1EA1TO-I-LF-111-STD](#) [SDINBDG4-32G-ZA](#) [SDINBDG4-32G-XA](#) [THGBMNG5D1LBAIT](#) [THGBMNG5D1LBAIL](#) [SDINBDG4-64G-XI1](#) [SDINADF4-128G](#) [SDINBDG4-64G-XA](#) [SDINBDG4-8G-XA](#) [SDINBDG4-32G-XI1](#) [SDINBDG4-16G-XA](#) [SDINBDA4-32G](#) [SDINBDG4-64G](#) [SDINBDG4-64G-ZA](#) [ASFC8G31M-51BIN](#) [ASFC4G31M-51BIN](#)