

DO NOT SCALE FROM THIS PRINT

- NOTES:
1. ASP-103597-01-B BODY FOR NON-STANDARD 19 POSITION.
 2. $\text{\textcircled{C}}$ REPRESENTS A CRITICAL DIMENSION.
 3. MAXIMUM BURR ALLOWANCE: .0005[0.013]
 4. MINIMUM PUSHOUT FORCE: .5 LB
 5. CONTACT TO BE FLUSH TO $\pm .002$ [0.05] TO BE MEASURED AT ALL FOUR CORNERS.
 6. ONE REEL MINIMUM PLATING REQUIREMENT (85,000 CONTACTS PER REEL).
 7. ALL DIMS TO BE SYMMETRICAL ABOUT THE CENTERLINE WITHIN $\pm .001$ [0.03].
 8. MAXIMUM VARIATION BETWEEN SOLDERBALLS: .0025[0.064]
 9. REFER TO VISUAL INSPECTION BOARD FOR SOLDERBALL APPEARANCE CHECKS.
 10. THE DISTANCE FROM THE CENTER OF ANY SOLDERBALL TO THE CENTER OF ANY ADJACENT INNER PEG SHALL BE $.025 \pm .005$ [0.64 \pm 0.13].
 11. SOLDER JOINTS TO BE INSPECTED PER IPC SPECIFICATION 12.2.12 (IPC-A-610C).
 12. PARTS TO BE PACKAGED IN TAPE & REEL. FOR QTY'S LESS THAN 125 PCS, NO TRAILER OR LEADER WILL BE SUPPLIED.
 13. NOTE DELETED.

ANY REV MADE TO THIS PRINT MUST HAVE AN UPDATED MKT PRINT

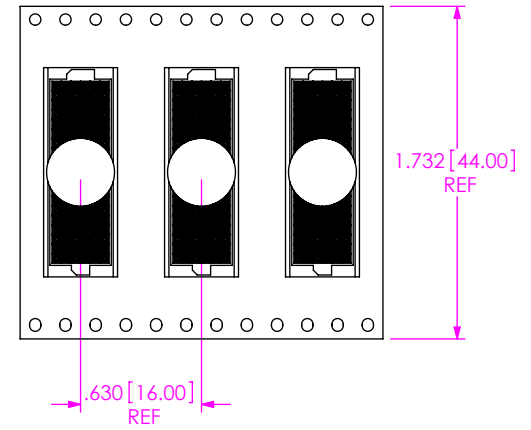
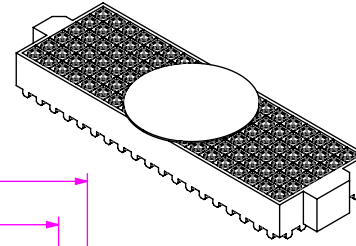
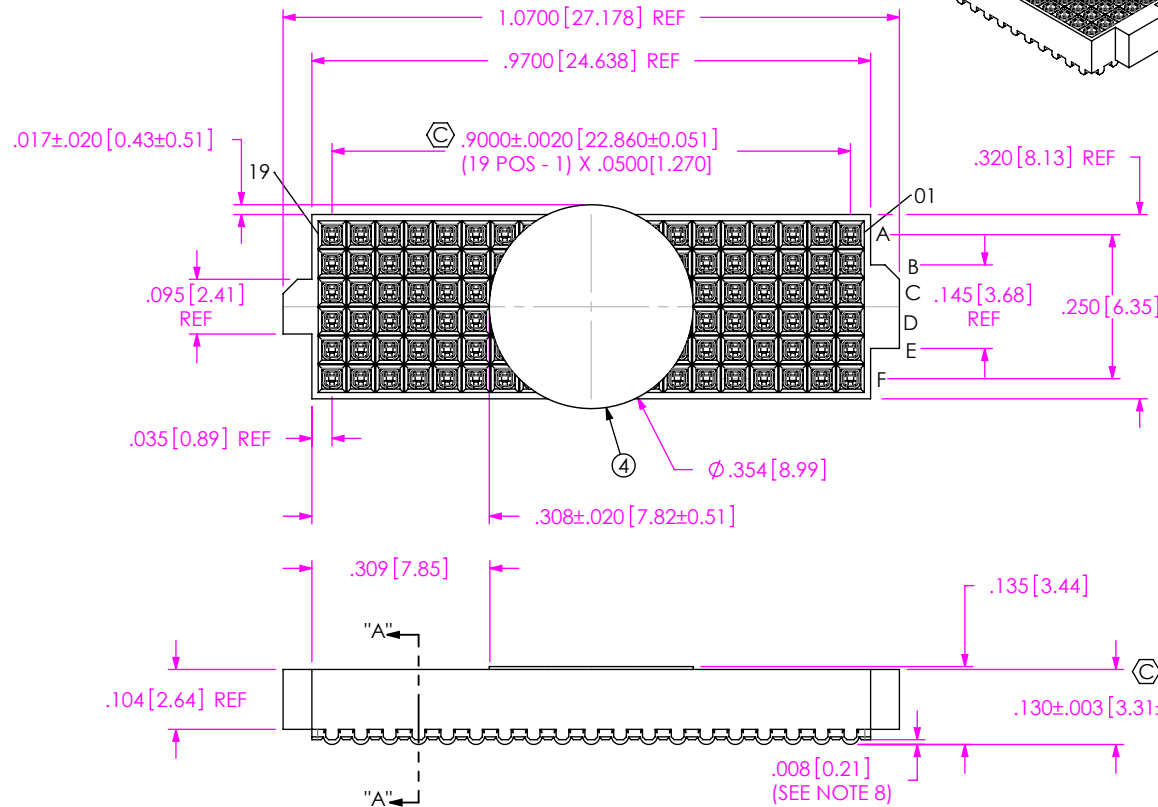

USER DIRECTION OF UN-REELING \rightarrow
POCKET NOT DETAILED



PACKAGING VIEW

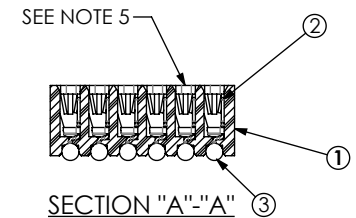

SECTION "A"- "A"

UNLESS OTHERWISE SPECIFIED, DIMENSIONS ARE IN INCHES.

TOLERANCES ARE:
DECIMALS ANGLES
.XX: $\pm .01$ [0.3]
.XXX: $\pm .005$ [0.13]
.XXXX: $\pm .0020$ [0.051]

PROPRIETARY NOTE
THIS DOCUMENT CONTAINS CONFIDENTIAL AND PROPRIETARY INFORMATION AND ALL DESIGN, MANUFACTURING, REPRODUCTION, USE, PATENT RIGHTS AND SALES RIGHTS ARE EXPRESSLY RESERVED BY SAMTEC, INC. THIS DOCUMENT SHALL NOT BE DISCLOSED, IN WHOLE OR PART, TO ANY UNAUTHORIZED PERSON OR ENTITY NOR REPRODUCED, TRANSFERRED OR INCORPORATED IN ANY OTHER PROJECT IN ANY MANNER WITHOUT THE EXPRESS WRITTEN CONSENT OF SAMTEC, INC.

DO NOT SCALE DRAWING SHEET SCALE: 3:1
PLATING:
CONTACT AREA: .000030 GOLD OVER .000050 NICKEL
REMAINDER: .000003 FLASH GOLD OVER .000050 NICKEL

DESCRIPTION:
VITA 42 (LEADED) SOCKET ASSEMBLY

DWG. NO. ASP-103612-05

BY: B. COOPER 12/08/06 SHEET 1 OF 2

ITEM NO.	PART NUMBER	QUANTITY	MATERIAL
1	ASP-103597-01-B	1.0000	UL 94 V0, COLOR: BLACK
2	C-226-03-H	114.00	PHOS BRONZE, 521 HARD TEMPER
3	SDB-030-6337	114.00	63% TIN /37% LEAD
4	K-DOT-.354-.469-.005	1.0000	POLYIMIDE FILM
5	CT-ASP1132MS	.00148	CONDUCTIVE POLYMER

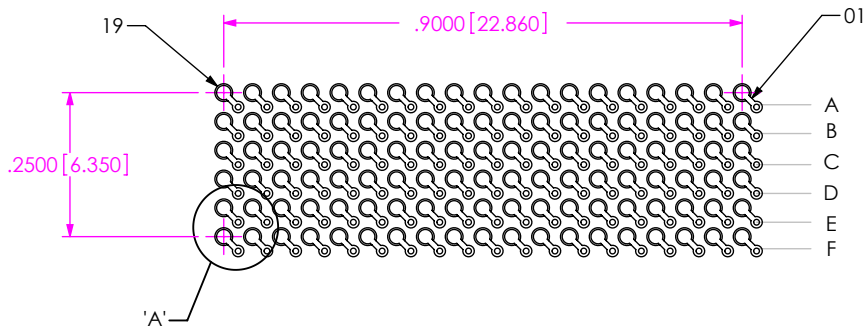

NOTE:
OUTER ROWS MAY NOT NEED VIAS - THIS IS LEFT TO
THE DISCRETION OF THE BOARD DESIGNER.

RECOMMENDED BOARD LAYOUT

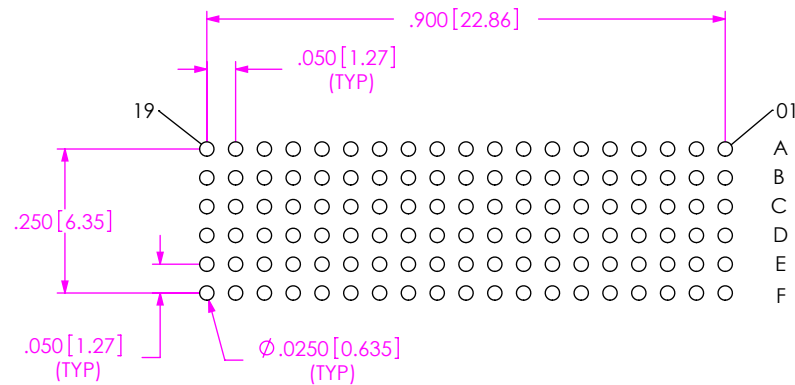
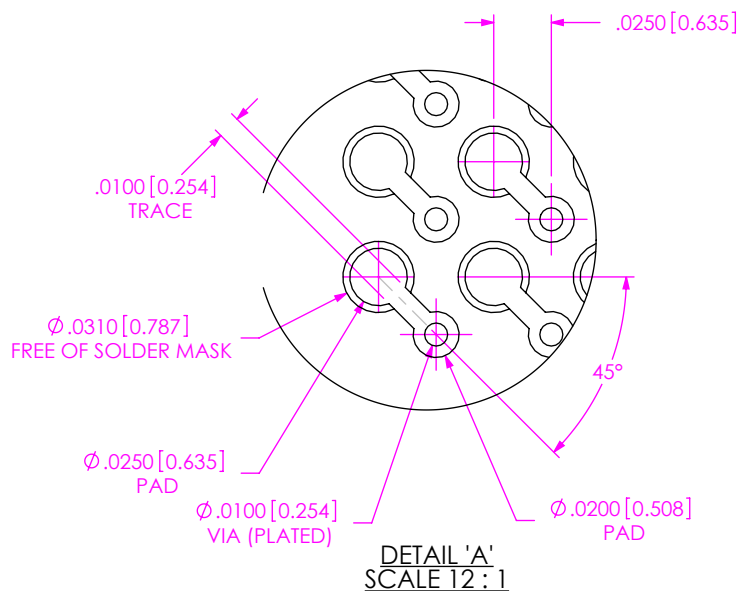

RECOMMENDED STENCIL LAYOUT
STENCIL TO BE .0060 [0.152] THICK

• PROPRIETARY NOTE •

THIS DOCUMENT CONTAINS CONFIDENTIAL AND PROPRIETARY INFORMATION AND ALL DESIGN, MANUFACTURING, REPRODUCTION, USE, PATENT RIGHTS AND SALES RIGHTS ARE EXPRESSLY RESERVED BY SAMTEC, INC. THIS DOCUMENT SHALL NOT BE DISCLOSED, IN WHOLE OR PART, TO ANY UNAUTHORIZED PERSON OR ENTITY NOR REPRODUCED, TRANSFERRED OR INCORPORATED IN ANY OTHER PROJECT IN ANY MANNER WITHOUT THE EXPRESS WRITTEN CONSENT OF SAMTEC, INC.



520 PARK EAST BLVD, NEW ALBANY, IN 47150
PHONE: 812-944-6733 FAX: 812-948-5047
e-Mail info@SAMTEC.com code 55322

SHEET SCALE: 3:1

DESCRIPTION:
VITA 42 (LEADED) SOCKET ASSEMBLY

DWG. NO.
ASP-103612-05

BY: B. COOPER 12/08/06 SHEET 2 OF 2

X-ON Electronics

Largest Supplier of Electrical and Electronic Components

Click to view similar products for [Board to Board & Mezzanine Connectors](#) category:

Click to view products by [Samtec](#) manufacturer:

Other Similar products are found below :

[589158040000018](#) [FCN-230C068-11](#) [FCN-268F012-G/BD](#) [FCN-268F036-G/BD](#) [FCN-268M012-G/0D](#) [FCN-268M024-G/1D](#) [FCN-723J004/1](#) [MIS-048-01-F-D-DP-K](#) [832-10-034-10-001000](#) [FX4C-80S-1.27DSA](#) [FCN-214Q030-G/0](#) [FCN-234P048-G/0](#) [FCN-235D050-G/C](#) [210-93-314-41-105000](#) [2-22603-0](#) [MDF7-40DP-2.54DSA\(55\)](#) [AXG720047](#) [5031084030](#) [MIT-114-03-F-D-K](#) [55323-1519](#) [DF33-2P-3.3DSA\(24\)](#) [YFT-20-05-H-03-SB-K](#) [503308-3040](#) [026-6203-PDB](#) [027-6203-PDB](#) [069159702701000](#) [10123981-102LF](#) [101A10019X](#) [55650-0588-C](#) [68684-306](#) [75140-7012](#) [589159005003045](#) [194261-1](#) [FCN-268F024-G0D](#) [10124054-515LF](#) [68685-603](#) [8-1616154-3](#) [MIS-019-01-F-D](#) [589159005002045](#) [541371078](#) [IL-WX-10PB-HF-B-E1000E](#) [FCN-268M024-G/3D](#) [20021832-06016C1LF](#) [KX15-20KLDL-E1000E](#) [MDF7-16DP-2.54DSA\(55\)](#) [AXE810124](#) [FCN-214J100-G/0](#) [FCN-230C068-E/S](#) [AXE812124](#) [AXE816124](#)