

DO NOT SCALE FROM THIS PRINT

- NOTES:
- ITEMS -1, -2, & -3 NOT AVAILABLE AS STANDARD, CUTOM FOR VARIATION OF VITA 42 XMC STANDARDS.
 - ⊕ REPRESENTS A CRITICAL DIMENSION.
 - MAXIMUM BURR ALLOWANCE: .0015[0.038]
 - MAXIMUM CUT FLASH: .010[0.25]
 - MINIMUM PUSHOUT FORCE: .5 LB [2.22N]
 - MAXIMUM ALLOWABLE BOW; TOP/BOTTOM: .006[0.15], SIDE/SIDE: .003[0.08]. ⊕
 - PARTS TO BE PACKAGED IN TAPE & REEL. FOR QTY'S LESS THAN 125 PCS, NO TRAILER OR LEADER WILL BE SUPPLIED.
 - LEAD FREE SOLDER BALLS

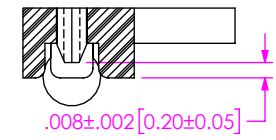

DETAIL 'G'
SCALE 10:1
SOLDER BALL REMOVED FOR CLARITY

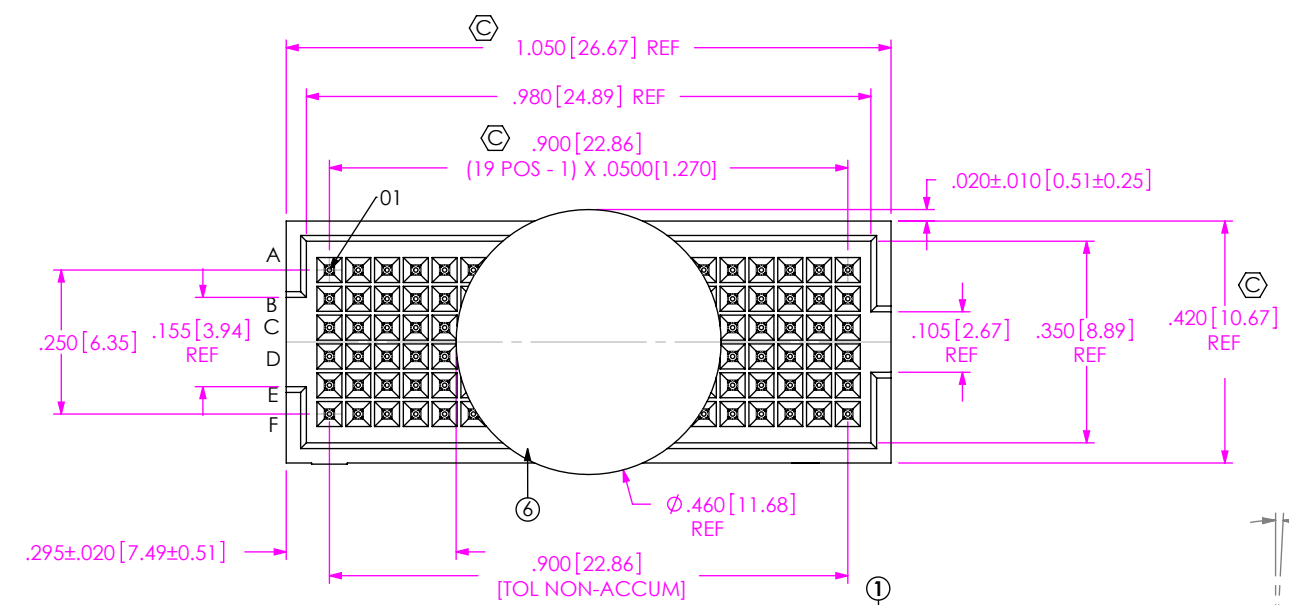
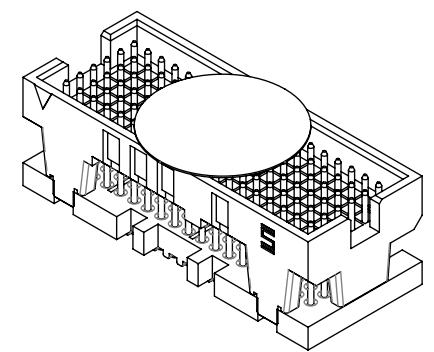
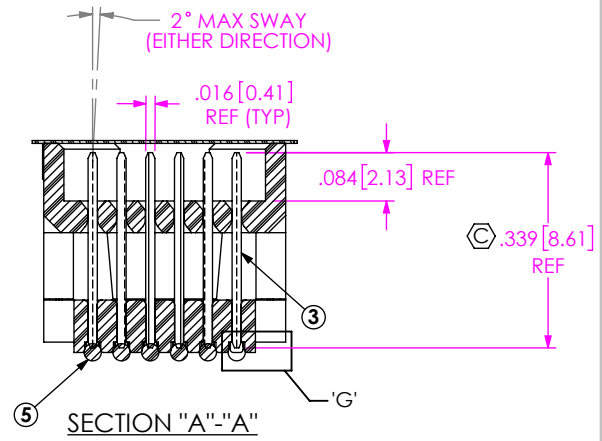
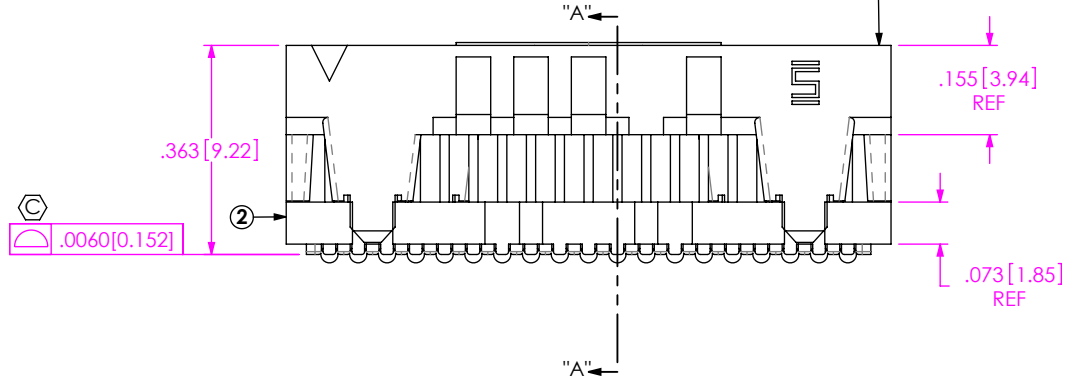

ITEM NO.	PART NUMBER	QUANTITY	MATERIAL
1	ASP-144052-01-B	1.0000	UL 94 V0, COLOR: BLACK
2	ASP-103599-01-B	1.0000	UL 94 V0, COLOR: BLACK
3	ASP-104554-02-P-H	114.00	BRASS ALLOY 260, 3/4 HARD
4	CT-ASP1134MS	.00571	CONDUCTIVE POLYMER
5	SDB-030-9653	114.00	96.5% TIN / 3% SILVER / 0.5% COPPER
6	K-850-650	1.0000	POLYIMIDE FILM

UNLESS OTHERWISE SPECIFIED, DIMENSIONS ARE IN INCHES.

TOLERANCES ARE:
 DECIMALS ANGLES
 .XX: ±.01[0.3] 2°
 .XXX: ±.005[0.13]
 .XXXX: ±.0020[0.051]

PROPRIETARY NOTE
 THIS DOCUMENT CONTAINS CONFIDENTIAL AND PROPRIETARY INFORMATION AND ALL DESIGN, MANUFACTURING, REPRODUCTION, USE, PATENT RIGHTS AND SALES RIGHTS ARE EXPRESSLY RESERVED BY SAMTEC, INC. THIS DOCUMENT SHALL NOT BE DISCLOSED, IN WHOLE OR PART, TO ANY UNAUTHORIZED PERSON OR ENTITY NOR REPRODUCED, TRANSFERRED OR INCORPORATED IN ANY OTHER PROJECT IN ANY MANNER WITHOUT THE EXPRESS WRITTEN CONSENT OF SAMTEC, INC.

DO NOT SCALE DRAWING SHEET SCALE: 3:1

PLATING: .000030 GOLD OVER .000050 NICKEL

DESCRIPTION:
 VITA 42 (LEAD FREE) SOCKET ASSEMBLY

DWG. NO. ASP-103614-04

BY: TAMMY W 09/11/06 SHEET 1 OF 2

F:\DWG\MISC\MKTG\ASP-103614-04-MKT.SLDRW



520 PARK EAST BLVD, NEW ALBANY, IN 47150
 PHONE: 812-944-6733 FAX: 812-948-5047
 e-Mail: info@SAMTEC.com code 55322

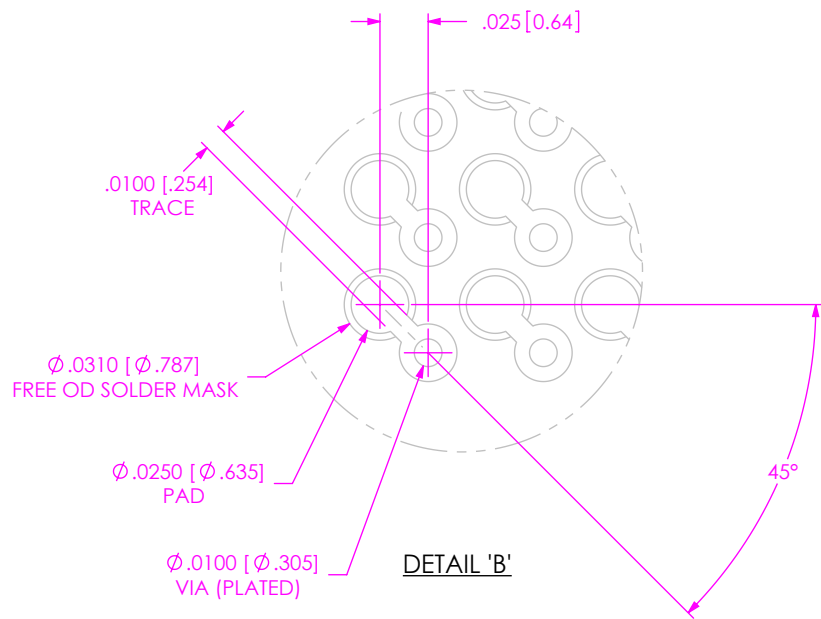
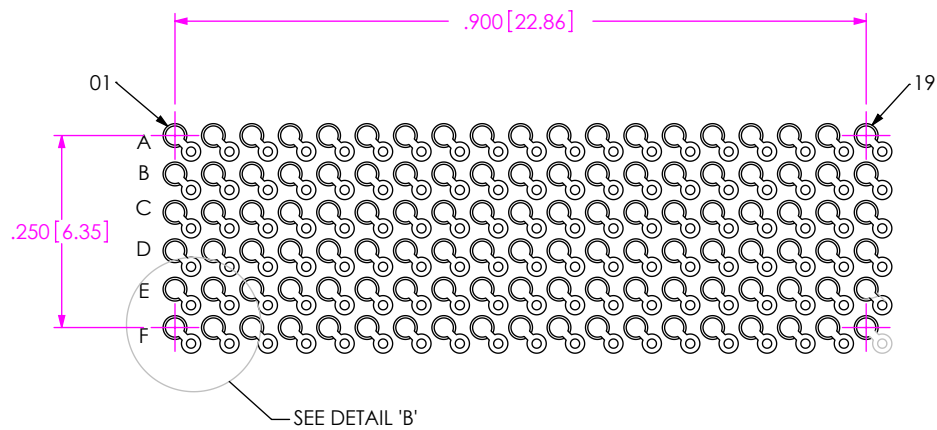

RECOMMENDED BOARD LAYOUT

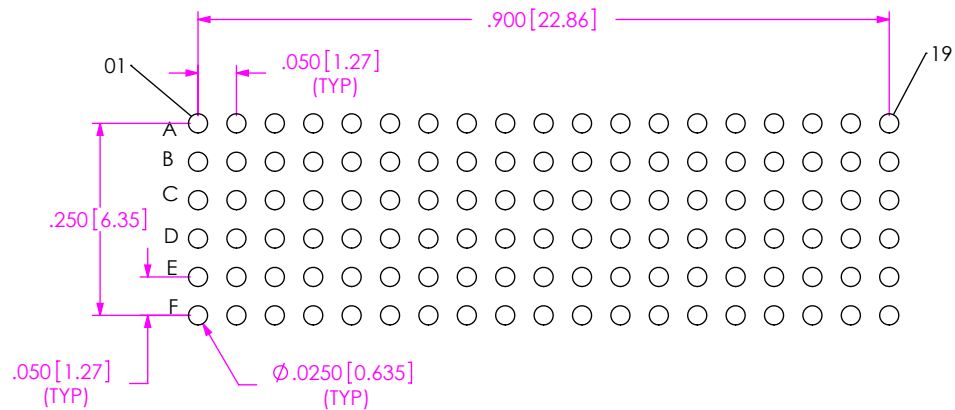

RECOMMENDED STENCIL LAYOUT
STENCIL TO BE $.0060 [0.152]$ THICK

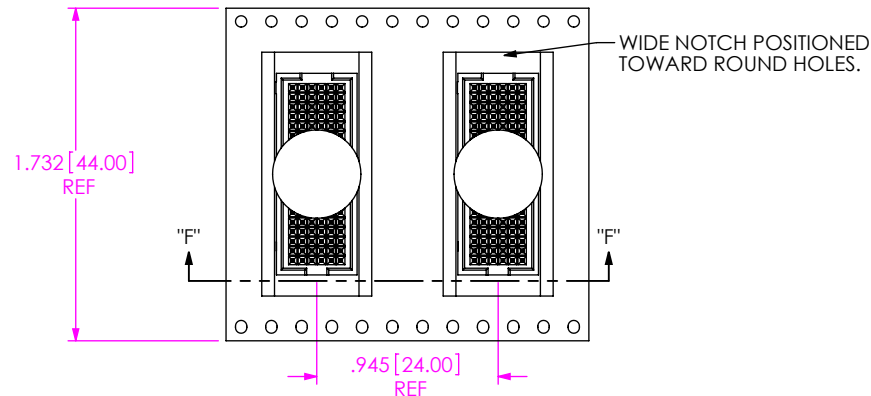

USER DIRECTION OF UN-REELING
POCKET NOT DETAILED

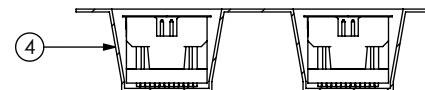

SECTION 'F'-'F'
SCALE 1 : 1
PACKAGING VIEW

PROPRIETARY NOTE

THIS DOCUMENT CONTAINS CONFIDENTIAL AND PROPRIETARY INFORMATION AND ALL DESIGN, MANUFACTURING, REPRODUCTION, USE, PATENT RIGHTS AND SALES RIGHTS ARE EXPRESSLY RESERVED BY SAMTEC, INC. THIS DOCUMENT SHALL NOT BE DISCLOSED, IN WHOLE OR PART, TO ANY UNAUTHORIZED PERSON OR ENTITY NOR REPRODUCED, TRANSFERRED OR INCORPORATED IN ANY OTHER PROJECT IN ANY MANNER WITHOUT THE EXPRESS WRITTEN CONSENT OF SAMTEC, INC.



520 PARK EAST BLVD. NEW ALBANY, IN 47150
PHONE: 812-944-6733 FAX: 812-948-5047
e-Mail info@SAMTEC.com code 55322

SHEET SCALE: 3:1

DESCRIPTION:
VITA 42 (LEAD FREE) SOCKET ASSEMBLY

DWG. NO.
ASP-103614-04

BY: TAMMY W 09/11/06

SHEET 2 OF 2

X-ON Electronics

Largest Supplier of Electrical and Electronic Components

Click to view similar products for [Board to Board & Mezzanine Connectors](#) category:

Click to view products by [Samtec](#) manufacturer:

Other Similar products are found below :

[589158040000018](#) [MDF7C-18P-2.54DSA\(55\)](#) [FCN-230C068-11](#) [FCN-268F012-G/BD](#) [FCN-268F036-G/BD](#) [FCN-268M012-G/0D](#) [FCN-268M024-G/1D](#) [FCN-723J004/1](#) [MIS-048-01-F-D-DP-K](#) [832-10-034-10-001000](#) [FX4C-80S-1.27DSA](#) [FCN-214Q030-G/0](#) [FCN-234P048-G/0](#) [FCN-235D050-G/C](#) [210-93-314-41-105000](#) [2-22603-0](#) [MDF7-40DP-2.54DSA\(55\)](#) [AXG720047](#) [5031084030](#) [MIT-114-03-F-D-K](#) [55323-1519](#) [DF33-2P-3.3DSA\(24\)](#) [YFT-20-05-H-03-SB-K](#) [503308-3040](#) [026-6203-PDB](#) [027-6203-PDB](#) [069159702701000](#) [10123981-102LF](#) [101A10019X](#) [55650-0588-C](#) [68684-306](#) [75140-7012](#) [589159005003045](#) [194261-1](#) [FCN-268F024-G0D](#) [10124054-515LF](#) [68685-603](#) [8-1616154-3](#) [MIS-019-01-F-D](#) [589159005002045](#) [541371078](#) [IL-WX-10PB-HF-B-E1000E](#) [FCN-268M024-G/3D](#) [20021832-06016C1LF](#) [KX15-20KLDL-E1000E](#) [MDF7-16DP-2.54DSA\(55\)](#) [AXE810124](#) [FCN-214J100-G/0](#) [FCN-230C068-E/S](#) [AXE812124](#)