

REVISION E

REVISION

C	JS	D FRALEY
12/23/2013 ECN-218154		
TOP VIEW MOVE C2 FROM .0825 REF TO .625; NOTES: CHG NOTE 2 FROM "HEX" REPRESENTS A CRITICAL DIMENSION;" TO "CPC" REPRESENTS A CRITICAL DIMENSION.; REPLACE CUSTOMER CRITICAL SYMBOLS WITH CPC SYMBOLS; DEL NON STANDARD BLOCK; SHT 2, SECT "A": CHG C1-B1-DC TO C3-B1-DC.		
D	JS	J HENRY
1/14/2014 ECN-219010		
SHT 2, SECT "A": CHG C3-B1-DC TO C3-B1-CP.		
E	TW	T WILD
10/7/2014 ECN-237503		
NOTES: ADD "SET UP FOR INDUSTRY STANDARD STACK HEIGHT OF 15.24MM"		

BY SIGNING THIS DOCUMENT YOU ARE ACCEPTING THE CONDITIONS SET WITHIN YOUR REQUIREMENTS MUST BE LISTED WITHIN THIS DRAWING; WHERE NO DIRECTION FROM THE CUSTOMER IS IDENTIFIED SAMTEC'S PROCESS REQUIREMENTS WILL BE USED.

DATE: _____
 COMPANY: _____
 CUSTOMER SIGNATURE: _____
 PRINTED NAME: _____
 PHONE NO: _____
 EXCEPTIONS: _____

- NOTES:
1. SET UP FOR INDUSTRY STANDARD STACK HEIGHT OF 15.24MM IS NOT AVAILABLE AS STANDARD.
 2. REPRESENTS A CRITICAL DIMENSION.
 3. BURR ALLOWANCE: .0015[0.038] MAX.
 4. MINIMUM PUSHOUT FORCE: SIGNAL: .5 LB, GROUND: 1 LB.
 5. MAX VARIANCE OF .002[0.05].
 6. DIMENSION APPLIES TO CONTACTS & GROUND PLANE.
 7. GROUND PLANE PRESS HEIGHT MUST BE .003[0.08] LESS THAN THE MAX HEIGHT OR .001[0.03] GREATER THAN THE MINIMUM HEIGHT OF THE CONTACT.
 8. PARTS TO BE PACKAGED IN TRAYS.

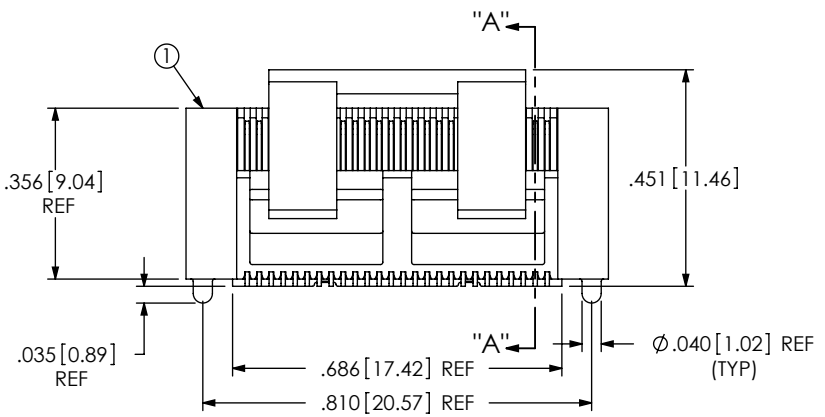
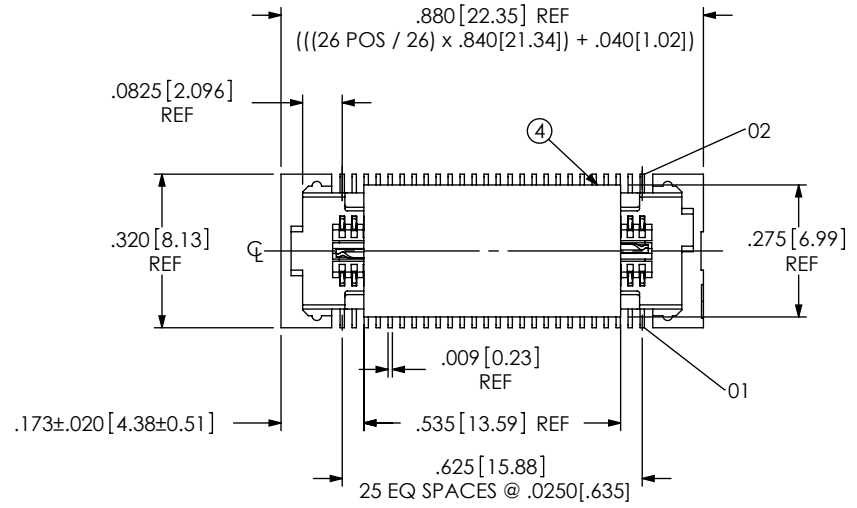
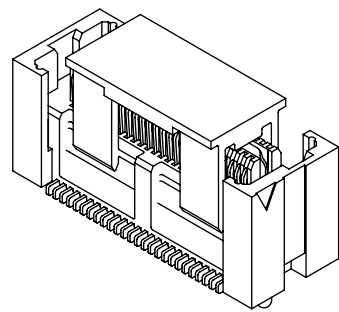

ITEM NO.	PART NUMBER	QUANTITY	MATERIAL
1	QFSS-26-06.25-D-01-A	1.0000	VECTRA E130i, COLOR: BLACK
2	C-223-06.25-S	52.0000	PHOS BRONZE, 521 EXTRA SPRING TEMPER
3	T-1G28-06.25-L	1.0000	PHOS BRONZE, 510 FULL HARD TEMPER
4	PPP-51	1.0000	46HF5040, COLOR: BLACK
5	TY-QFS012-026-6.25	1.0000	BLACK HIPS

UNLESS OTHERWISE SPECIFIED, DIMENSIONS ARE IN INCHES. TOLERANCES ARE:
 DECIMALS ANGLES
 .XX: ±.01 [.3] 2°
 .XXX: ±.005 [.13]
 .XXXX: ±.0020 [.051]

PROPRIETARY NOTE
 THIS DOCUMENT CONTAINS INFORMATION CONFIDENTIAL AND PROPRIETARY TO SAMTEC, INC. AND SHALL NOT BE REPRODUCED OR TRANSFERRED TO OTHER DOCUMENTS OR DISCLOSED TO OTHERS OR USED FOR ANY PURPOSE OTHER THAN THAT WHICH IT WAS OBTAINED WITHOUT THE EXPRESSED WRITTEN CONSENT OF SAMTEC, INC.



520 PARK EAST BLVD, NEW ALBANY, IN 47150
 PHONE: 812-944-6733 FAX: 812-948-5047
 e-Mail: info@SAMTEC.com code: 55322

DO NOT SCALE DRAWING SHEET SCALE: 2.5:1
 PLATING:
 CONTACT AREA: .000030 GOLD OVER .000050 NICKEL
 REMAINDER: .000200 REF TIN OVER .000050 NICKEL
 F:\DWG\MISC\MKTG\ASP-129646-01-MKT.SLDDRW

DESCRIPTION: ELEVATED QFS
 DWG. NO. ASP-129646-01
 BY: CLAY W 12/13/2006 SHEET 1 OF 2

RECOMMENDED PCB LAYOUT

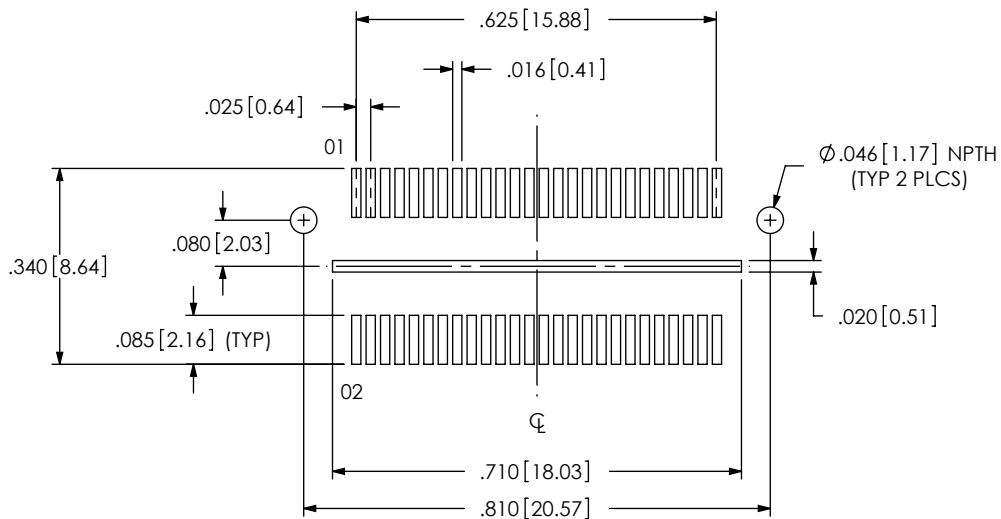

(ALL DIMENSIONS ARE SYMMETRIC ABOUT THE CENTERLINE)

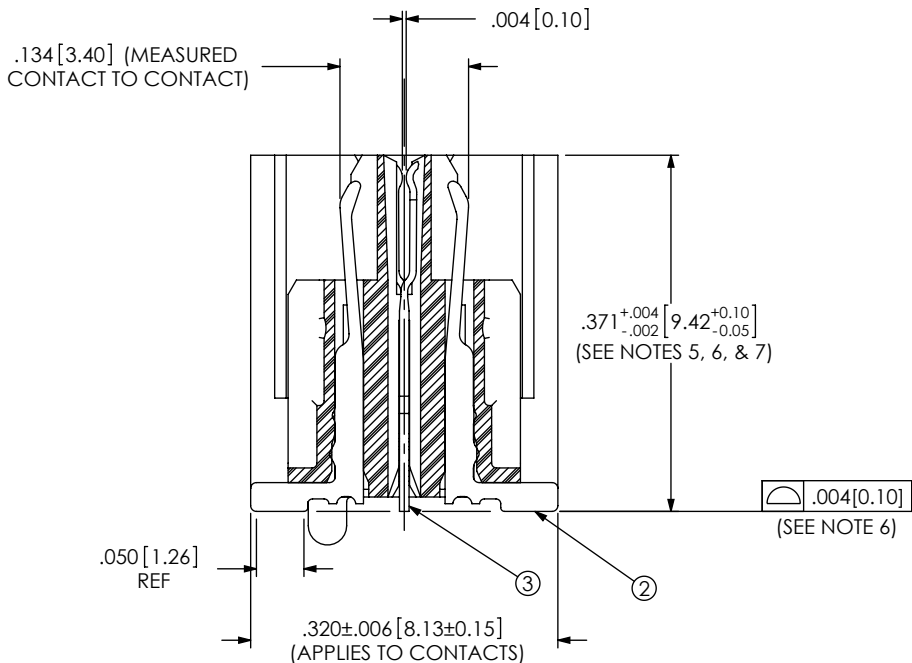

SECTION "A"-A"

ITEM 4 NOT SHOWN FOR CLARITY

IN-PROCESS

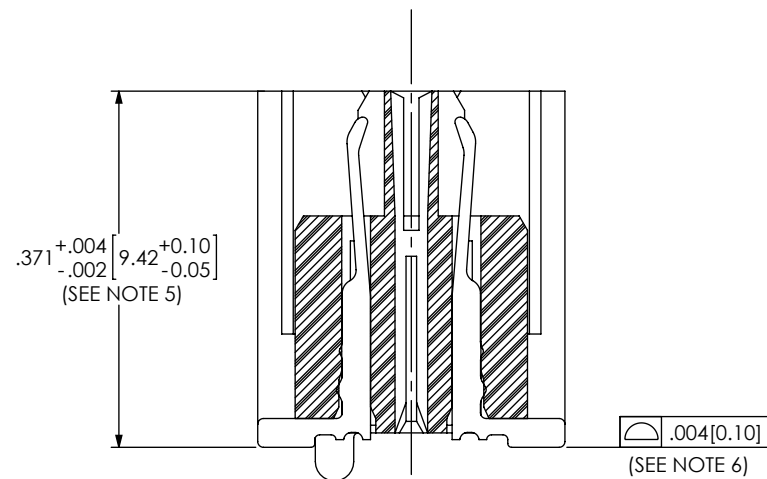

VIEW

PROPRIETARY NOTE

THIS DOCUMENT CONTAINS INFORMATION CONFIDENTIAL AND PROPRIETARY TO SAMTEC, INC. AND SHALL NOT BE REPRODUCED OR TRANSFERRED TO OTHER DOCUMENTS OR DISCLOSED TO OTHERS OR USED FOR ANY PURPOSE OTHER THAN THAT WHICH IT WAS OBTAINED WITHOUT THE EXPRESSED WRITTEN CONSENT OF SAMTEC, INC.



520 PARK EAST BLVD., NEW ALBANY, IN 47150
 PHONE: 812-944-6733 FAX: 812-948-5047
 e-Mail: info@SAMTEC.com code: 55322

SHEET SCALE: 5:1

DESCRIPTION:

ELEVATED QFS

DWG. NO.

ASP-129646-01

BY: CLAY W

12/13/2006

SHEET 2 OF 2

X-ON Electronics

Largest Supplier of Electrical and Electronic Components

Click to view similar products for [Board to Board & Mezzanine Connectors](#) category:

Click to view products by [Samtec](#) manufacturer:

Other Similar products are found below :

[589158040000018](#) [FCN-230C068-11](#) [FCN-268F012-G/BD](#) [FCN-268F036-G/BD](#) [FCN-268M012-G/0D](#) [FCN-268M024-G/1D](#) [FCN-723J004/1](#) [MIS-048-01-F-D-DP-K](#) [832-10-034-10-001000](#) [FX4C-80S-1.27DSA](#) [FCN-214Q030-G/0](#) [FCN-234P048-G/0](#) [FCN-235D050-G/C](#) [210-93-314-41-105000](#) [2-22603-0](#) [MDF7-40DP-2.54DSA\(55\)](#) [AXG720047](#) [5031084030](#) [MIT-114-03-F-D-K](#) [55323-1519](#) [DF33-2P-3.3DSA\(24\)](#) [YFT-20-05-H-03-SB-K](#) [503308-3040](#) [026-6203-PDB](#) [027-6203-PDB](#) [069159702701000](#) [10123981-102LF](#) [101A10019X](#) [55650-0588-C](#) [68684-306](#) [75140-7012](#) [589159005003045](#) [194261-1](#) [FCN-268F024-G0D](#) [10124054-515LF](#) [68685-603](#) [8-1616154-3](#) [MIS-019-01-F-D](#) [589159005002045](#) [541371078](#) [IL-WX-10PB-HF-B-E1000E](#) [FCN-268M024-G/3D](#) [20021832-06016C1LF](#) [KX15-20KLDL-E1000E](#) [MDF7-16DP-2.54DSA\(55\)](#) [AXE810124](#) [FCN-214J100-G/0](#) [FCN-230C068-E/S](#) [AXE812124](#) [AXE816124](#)