

NOTES:

1. CUSTOM BODY NOT AVAILABLE AS STANDARD.
2. REPRESENTS A CRITICAL DIMENSION.
3. MAXIMUM BURR ALLOWANCE: .0015[0.038]
4. MINIMUM PUSHOUT FORCE: SIGNAL: .5 LB, GROUND: 1 LB
5. MAX VARIANCE OF .002[0.05]
6. DIMENSION APPLIES TO CONTACTS & GROUND PLANE.
7. GROUND PLANE PRESS HEIGHT MUST BE .003[0.08] LESS THAN THE MAX HEIGHT OR .001[0.03] GREATER THAN THE MINIMUM HEIGHT OF THE CONTACT.
8. MAXIMUM CUT FLASH: .010[0.25]
9. PARTS TO BE PACKAGED IN TRAYS.

DO NOT SCALE FROM THIS PRINT

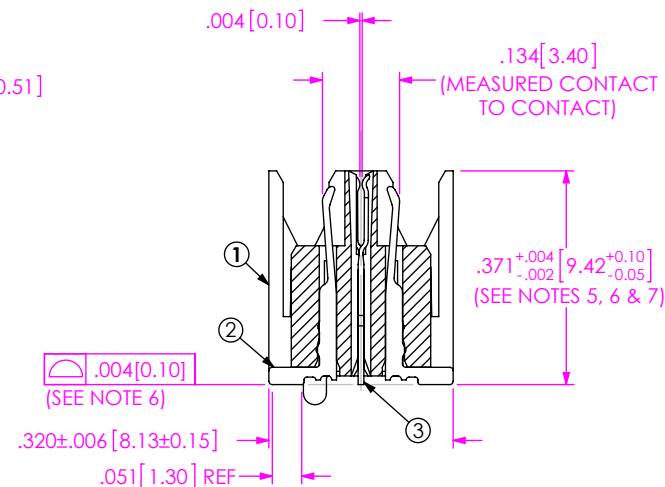
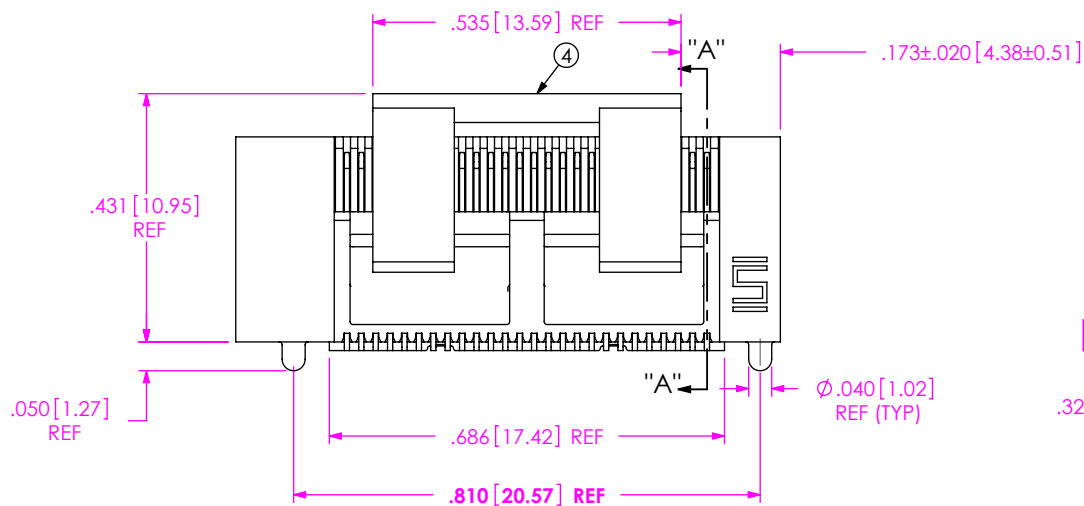
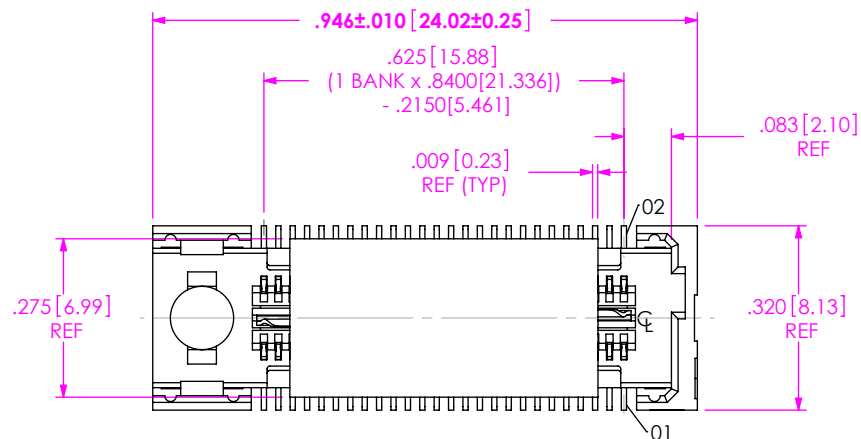
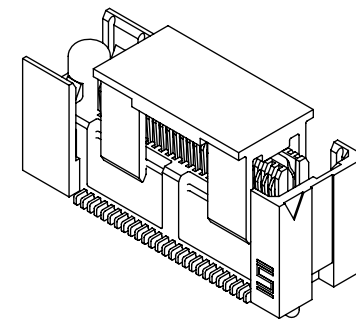

SECTION "A"-"A"
PICK & PLACE PAD NOT SHOWN FOR CLARITY

BY SIGNING THIS DOCUMENT YOU ARE ACCEPTING THE CONDITIONS SET WITHIN. YOUR REQUIREMENTS MUST BE LISTED WITHIN THIS DRAWING. WHERE NO DIRECTION FROM THE CUSTOMER IS IDENTIFIED SAMTEC'S PROCESS REQUIREMENTS WILL BE USED.

DATE: _____
 COMPANY: _____
 CUSTOMER SIGNATURE: _____
 PRINTED NAME: _____
 PHONE NO: _____
 EXCEPTIONS: _____

UNLESS OTHERWISE SPECIFIED, DIMENSIONS ARE IN INCHES. TOLERANCES ARE: DECIMALS ANGLES .XX: ±.01 [.3] 2° .XXX: ±.005 [.13] .XXXX: ±.0020 [.051]	PROPRIETARY NOTE THIS DOCUMENT CONTAINS INFORMATION CONFIDENTIAL AND PROPRIETARY TO SAMTEC, INC. AND SHALL NOT BE REPRODUCED OR TRANSFERRED TO OTHER DOCUMENTS OR DISCLOSED TO OTHERS OR USED FOR ANY PURPOSE OTHER THAN THAT WHICH IT WAS OBTAINED WITHOUT THE EXPRESSED WRITTEN CONSENT OF SAMTEC, INC.	 520 PARK EAST BLVD, NEW ALBANY, IN 47150 PHONE: 812-944-6733 FAX: 812-948-5047 e-Mail: info@SAMTEC.com code 53322
	PLATING: DO NOT SCALE DRAWING SHEET SCALE: 3:1 CONTACTS: CONTACT AREA: .000030 GOLD OVER .000050 NICKEL REMAINDER: .000200 REF TIN OVER .000050 NICKEL GROUND PLANE: CONTACT AREA: .000010 GOLD OVER .000050 NICKEL REMAINDER: .000200 REF TIN OVER .000050 NICKEL	

ITEM NO.	PART NUMBER	QUANTITY	MATERIAL
1	ASP-144730-03-B	1.0000	VECTRA E130i, COLOR: BLACK
2	C-223-06.25-S	52.0000	PHOS BRONZE
3	T-1G28-06.25-L	1.0000	PHOS BRONZE
4	PPP-51	1.0000	VECTRA E130, COLOR: BLACK
5	TY-ASP146	1.0000	BLACK HIPS

RECOMMENDED PCB LAYOUT
 (ALL DIMENSIONS ARE SYMMETRIC ABOUT THE CENTERLINE)

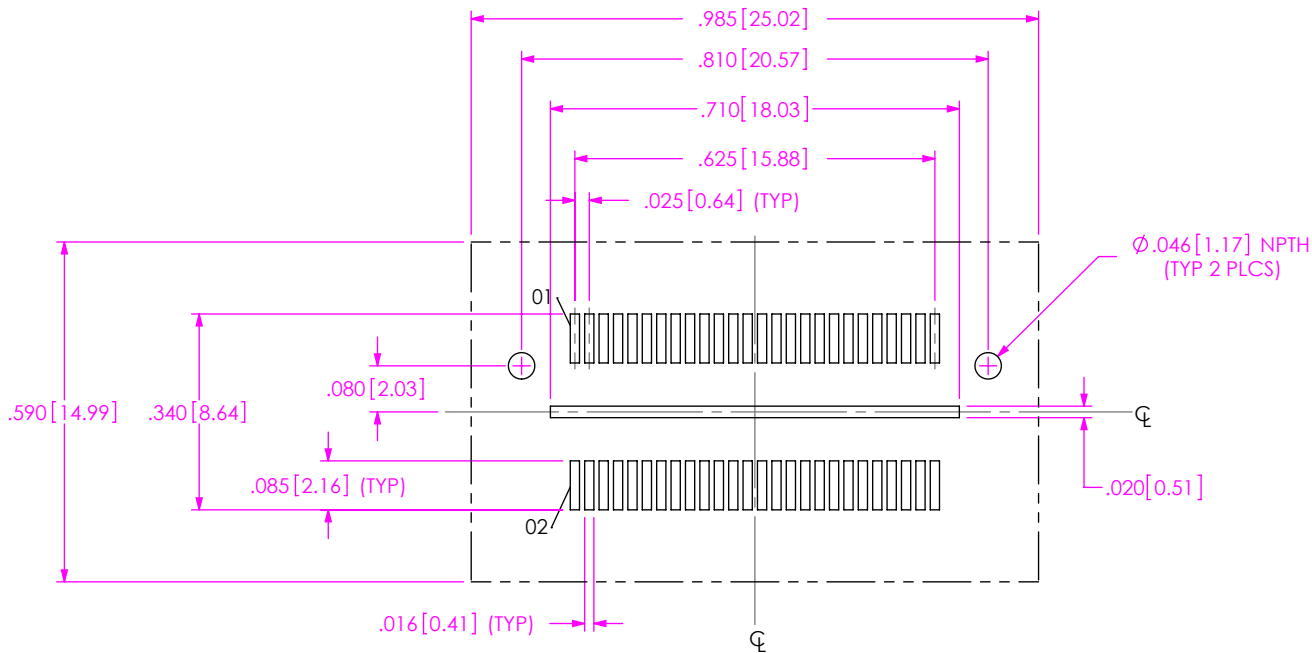

PROPRIETARY NOTE

THIS DOCUMENT CONTAINS INFORMATION CONFIDENTIAL AND PROPRIETARY TO SAMTEC, INC. AND SHALL NOT BE REPRODUCED OR TRANSFERRED TO OTHER DOCUMENTS OR DISCLOSED TO OTHERS OR USED FOR ANY PURPOSE OTHER THAN THAT WHICH IT WAS OBTAINED WITHOUT THE EXPRESSED WRITTEN CONSENT OF SAMTEC, INC.



520 PARK EAST BLVD., NEW ALBANY, IN 47150
 PHONE: 812-944-6733 FAX: 812-948-5047
 e-Mail info@SAMTEC.com code 55322

SHEET SCALE: 5:1

DESCRIPTION: MODIFIED ELEVATED QFS

DWG. NO. ASP-129646-22

X-ON Electronics

Largest Supplier of Electrical and Electronic Components

Click to view similar products for [Board to Board & Mezzanine Connectors](#) category:

Click to view products by [Samtec](#) manufacturer:

Other Similar products are found below :

[589158040000018](#) [MDF7C-18P-2.54DSA\(55\)](#) [FCN-230C068-11](#) [FCN-268F012-G/BD](#) [FCN-268F036-G/BD](#) [FCN-268M012-G/0D](#) [FCN-268M024-G/1D](#) [FCN-723J004/1](#) [MIS-048-01-F-D-DP-K](#) [832-10-034-10-001000](#) [FX4C-80S-1.27DSA](#) [FCN-214Q030-G/0](#) [FCN-234P048-G/0](#) [FCN-235D050-G/C](#) [210-93-314-41-105000](#) [2-22603-0](#) [MDF7-40DP-2.54DSA\(55\)](#) [AXG720047](#) [5031084030](#) [MIT-114-03-F-D-K](#) [55323-1519](#) [DF33-2P-3.3DSA\(24\)](#) [YFT-20-05-H-03-SB-K](#) [503308-3040](#) [026-6203-PDB](#) [027-6203-PDB](#) [069159702701000](#) [10123981-102LF](#) [101A10019X](#) [55650-0588-C](#) [68684-306](#) [75140-7012](#) [589159005003045](#) [194261-1](#) [FCN-268F024-G0D](#) [10124054-515LF](#) [68685-603](#) [8-1616154-3](#) [MIS-019-01-F-D](#) [589159005002045](#) [541371078](#) [IL-WX-10PB-HF-B-E1000E](#) [FCN-268M024-G/3D](#) [20021832-06016C1LF](#) [KX15-20KLDL-E1000E](#) [MDF7-16DP-2.54DSA\(55\)](#) [AXE810124](#) [FCN-214J100-G/0](#) [FCN-230C068-E/S](#) [AXE812124](#)