

ALL DIMENSIONS ARE REFERENCE
(SEE C-203-XXXX-XX FOR CONTROLLING PRINT)

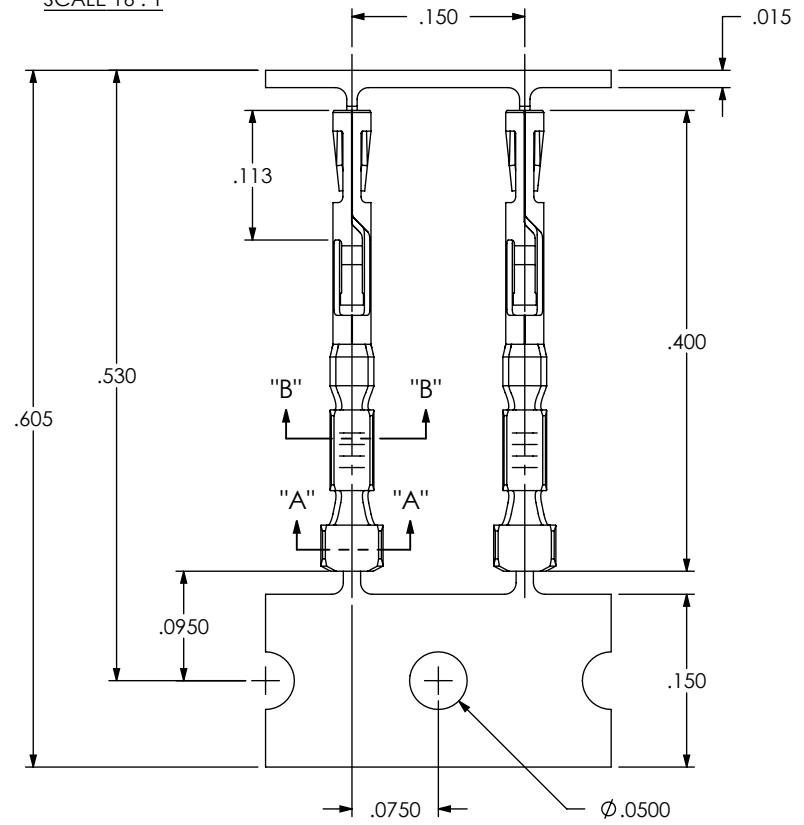

CC03X-XXXX-01-XX

SUPPLIED
L: LOOSE
R: REEL
M: MINI REEL

PLATING SPECIFICATION
-GF: 3µ" FLASH SELECTIVE IN CONTACT AREA,
3µ" GOLD ON TAIL
-G: 10µ" LIGHT GOLD IN CONTACT AREA,
3µ" GOLD ON TAIL
-H: 30µ" HEAVY GOLD IN CONTACT AREA,
3µ" GOLD ON TAIL

LEAD STYLE
-2830: 28-30 AWG

OPTION
INSULATION THICKNESS:

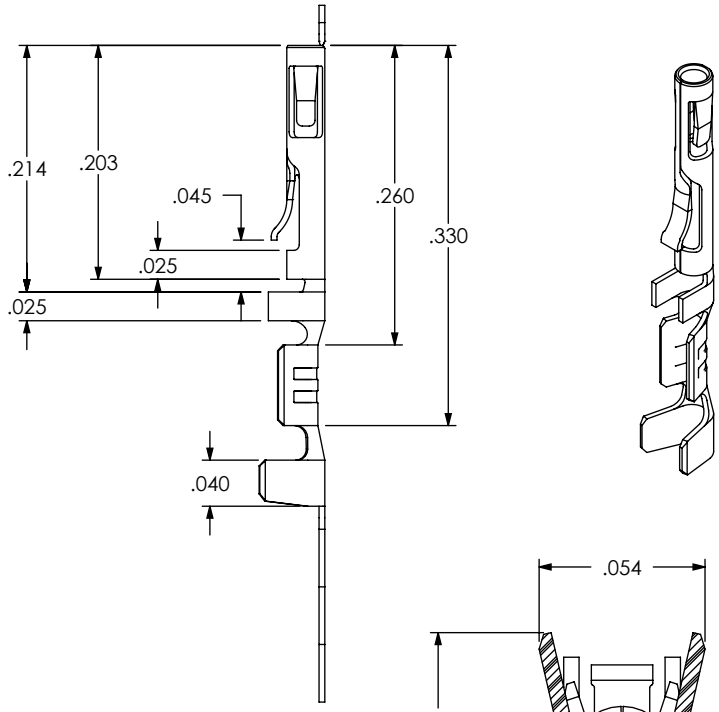

FIG 1
(CC03X-2830-0T-X SHOWN)

- NOTES:
1. PLATED C-203 PARTS TO BE PULLED, PLATING OPTION CONFIRMED, POSITIONED AS SHOWN ON SAMTEC REEL WITH VIEWPORTS, LABELED CC03R WITH APPROPRIATE PLATING CALLOUT AND LABEL PLACED AS SHOWN.
 2. MAXIMUM No OF SPLICES PER REEL:
-R: 2
-M: 1
 3. SPLICES ARE NOT TO BE CONNECTED.
 4. NUMBER OF SPLICES TO BE MARKED ON EACH REEL.
 5. REELED PARTS TO BE INTERLEAVED WITH PAPER BETWEEN EACH LAYER OF PARTS.
 6. ALLOWABLE INTERLEAF SPLICES PER REEL:
-R: 3
-M: 1
 7. SECURELY CONNECT INTERLEAF SPLICE.
 8. OUTER WRAP SHALL RECEIVE RB-24-0.75-P PROTECTIVE REEL BAND.
 9. DUE TO PLATING REQUIREMENTS CONTACT SAMPLES MAY BE REMOVED INTERMITTINGLY FROM THE CARRIER RESULTING IN SMALL GAPS BUT DOES NOT AFFECT FINAL COUNT.
 10. QTY PER REEL:
-R: 35,000 +700/-0 PCS
-M: 5,000 +300/-0 PCS

UNLESS OTHERWISE SPECIFIED,
DIMENSIONS ARE IN INCHES.
TOLERANCES ARE:
DECIMALS ANGLES

PROPRIETARY NOTE
THIS DOCUMENT CONTAINS INFORMATION
CONFIDENTIAL AND PROPRIETARY TO
SAMTEC, INC. AND SHALL NOT BE REPRODUCED
OR TRANSFERRED TO OTHER DOCUMENTS OR
DISCLOSED TO OTHERS OR USED FOR ANY
PURPOSE OTHER THAN THAT WHICH IT WAS
OBTAINED WITHOUT THE EXPRESSED WRITTEN
CONSENT OF SAMTEC, INC.



520 PARK EAST BLVD, NEW ALBANY, IN 47150
PHONE: 812-944-6733 FAX: 812-948-5047
e-Mail: info@SAMTEC.com code: 55322

MATERIAL: DO NOT SCALE DRAWING SHEET SCALE: 6:1
BeCu
THICKNESS: .0050

DESCRIPTION: .050" C.L. DISCRETE WIRE CONTACT
DWG. NO. CC03X-XXXX-01-XX

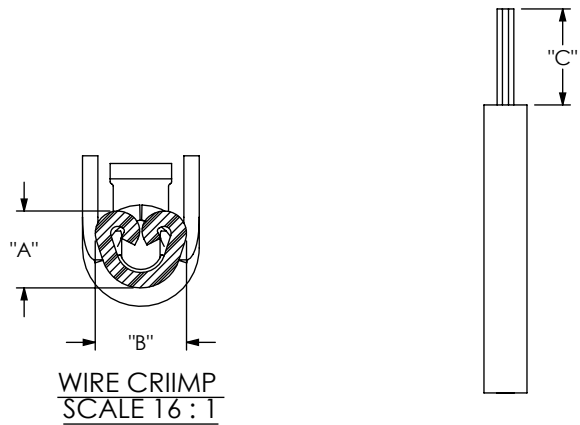

INSULATION STRIP LENGTH

P/N	AWG	STRANDS/AWG	INSULATION OD	"A"	"B"	"C"
CC03X-2830-01-XX	30	7/38	.0290-.0380	0.0170	0.0300	0.105
	28	7/36		0.0180	0.0300	

FIG 2
RECOMENDED PROCESSING

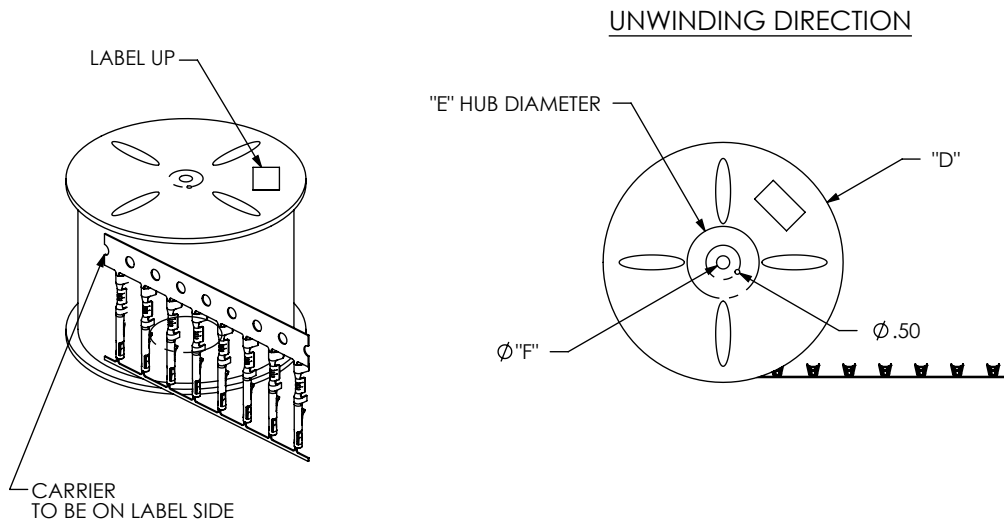

FIG 3
REEL SPECIFICATIONS

SUPPLIED	REEL PART NUMBER	"D"	"E"	"F"
-R	R-24-05.00-0.50-P	24.0	5.50	1.125
-M	MR-12-5.375-0.50-C	12.0	5.375	1.000

PROPRIETARY NOTE
THIS DOCUMENT CONTAINS INFORMATION CONFIDENTIAL AND PROPRIETARY TO SAMTEC, INC. AND SHALL NOT BE REPRODUCED OR TRANSFERRED TO OTHER DOCUMENTS OR DISCLOSED TO OTHERS OR USED FOR ANY PURPOSE OTHER THAN THAT WHICH IT WAS OBTAINED WITHOUT THE EXPRESSED WRITTEN CONSENT OF SAMTEC, INC.

DO NOT SCALE DRAWING

SHEET SCALE: 6:1



520 PARK EAST BLVD, NEW ALBANY, IN 47150
PHONE: 812-944-6733 FAX: 812-948-5047
e-Mail: info@SAMTEC.com code: 55322

DESCRIPTION: .050" C.L. DISCRETE WIRE CONTACT

DWG. NO. CC03X-XXXX-01-XX

BY: BRATCHER 3/8/2005 SHEET 2 OF 2

X-ON Electronics

Largest Supplier of Electrical and Electronic Components

Click to view similar products for [Terminal Block Tools & Accessories](#) category:

Click to view products by [Samtec](#) manufacturer:

Other Similar products are found below :

[1029563](#) [00171430102](#) [00171420102](#) [014415](#) [CSTSPC1-2](#) [9-1437653-4](#) [928358-1](#) [QC209/J](#) [HCL10-6](#) [1437403-6](#) [1437403-9](#) [1437403-8](#)
[EC0037-000](#) [MT2/H--](#) [MT2/H-32](#) [MT6/H-N](#) [MT6/V-GRND](#) [MT8/H-101-110](#) [BB2-09BF](#) [EP2.5/4UN/BG](#) [1707755](#) [1735590](#) [1755480](#)
[1760336](#) [BO3-02](#) [1789281](#) [1840227](#) [1840230](#) [1893164](#) [2-1437402-1](#) [2-1437644-9](#) [JB2-09/J](#) [2202307](#) [2302463](#) [2305949](#) [2310581](#) [8TK2-24](#)
[91.201.1](#) [L2U2](#) [2778.0](#) [2890137](#) [2901107](#) [2901123](#) [2901699](#) [2MP/J](#) [2MV-06](#) [1705126](#) [1756294](#) [F03-25](#) [1810532](#)