

DO NOT SCALE FROM THIS PRINT

- NOTES:
- ⊗ REPRESENTS A CRITICAL DIMENSION.
 - BURR ALLOWANCE: .003[.08] MAX.
 - PARTS TO BE MOLDED TO POSITION.
 - MINIMUM PIN PULLOUT FORCE: 4.000LB[17.79N]
 - CONTACT MUST BE INSERTED UNTIL RETENTION FEATURE LOCKS INTO PLACE.
 - ALL FINISHED GOODS ARE TO BE ELECTRICAL TESTED INCLUDING HI-POT TEST @ 1000 VOLTS DC. AFTER FINAL ELECTRICAL TEST, LABEL EACH ASSEMBLY WITH (1) ET STAMP ON THE BODY. ⊗
 - TINNED COPPER WIRE IS ROHS COMPLIANT.
 - FOLLOW CO-RF-WI-3001-M AND SAMTEC PACKAGING STANDARDS.
 - MINIMUM METAL LATCH RETENTION FORCE: 1.000LB[4.45N]
 - REFER TO CRIMP SPECIFICATIONS PRINT FOR CRIMP AND STRIP DIMENSIONS, TOLERANCES, TOOLING AND ITS REQUIREMENTS.
 - FOR LENGTHS LESS THAN 12 IN, TOLERANCE SHALL BE ±.125[3.18]. FOR OTHER LENGTHS, TOLERANCES SHALL BE ±2%.
 - LOCATION OF GATE PAD IS AT THE DISCRETION OF THE VENDOR.
 - GOLD PLATING IS NOT REQUIRED ON THE OUTSIDE OF THE CONTACT BOX OR ON THE SIDE WITH THE RETENTION LANCE.
 - ASSEMBLES USING THE FEP OPTION ARE FOR CRIMP APPLICATIONS ONLY.
 - CUT LENGTH IS ASSEMBLY LENGTH MINUS OVERALL LENGTH SUBTRACTOR.
 - NYLON MATERIALS ARE HYGROSCOPIC. PRODUCT MAY EXPAND UP TO 0.5% DEPENDING ON CONDITIONS OF THE SURROUNDING ENVIRONMENT. ALL PRINT DIMENSIONS REPRESENT "DRY AS MOLDED" STATE.
 - POSITIONS -02 THROUGH -05 DO NOT HAVE VOIDS.

MMSDX-XX-XXX-X-XX.XX-X-X-XXX

- FEP CABLE OPTION
-F: FEP INSULATION (LEAVE BLANK FOR STANDARD PVC INSULATION) (SEE NOTE 14)
- No OF POSITIONS
-02 THRU -25 (PER ROW)
- WIRE GAUGE (AWG)
PVC: -20, -22, -24, -26, -28, -30
FEP: -20, -24-28-30
- COLOR CODE
C (SEE TABLE 3, SHEET 3) (LEAVE BLANK FOR STANDARD BLACK CABLE)
(NOT AVAILABLE FOR TEFLON OPTION, TEFLON CABLE ONLY AVAILABLE IN BLUE)
- PLATING SPECIFICATION
-F: 3 μ" SELECTIVE GOLD IN CONTACT AREA, BRIGHT TIN ON TAIL.
-L: 10 μ" SELECTIVE GOLD IN CONTACT AREA, BRIGHT TIN ON TAIL.
-S: 30 μ" SELECTIVE GOLD IN CONTACT AREA, BRIGHT TIN ON TAIL.
- ASSEMBLED LENGTH
SPECIFY IN INCHES [USE DWC-XX-XX] (SINGLE END: 03.00 INCH MINIMUM, DOUBLE END: 03.25 INCH MINIMUM)
- END OPTION
-S: SINGLE END
-D: DOUBLE END (MUST CHOOSE FROM LUS, LDS, LUX, LDX, MUS, MDS, MUX, OR MDX)
- OPTION
SINGLE
-M: METAL LATCH (USE IPD1-XX-D-X-M) (LEAVE BLANK FOR PLASTIC)
- DOUBLE
-LUS: PLASTIC LATCH UP, STRAIGHT
-LDS: PLASTIC LATCH DOWN, STRAIGHT
-LUX: PLASTIC LATCH UP, CROSSED
-LDX: PLASTIC LATCH DOWN, CROSSED
-MUS: METAL LATCH UP, STRAIGHT
-MDS: METAL LATCH DOWN, STRAIGHT
-MUX: METAL LATCH UP, CROSSED
-MDX: METAL LATCH DOWN, CROSSED
- POLARIZATION OPTION
(-P, -K, OR -G OPTION IS REQUIRED.)
-P: POLARIZATION (SEE FIG 3, SHEET 2) (NOT AVAILABLE WITH -LUS, -LDS, -LUX, -K, -G OPTIONS)
-K: KEYED POLARIZATION (USE IPD1-XX-D-K) (SEE FIG 4, SHEET 2) (NOT AVAILABLE WITH -P, -G OPTIONS)
-G: GUIDE POST (USE IPD1-XX-D-GP) (SEE FIG 6, SHEET 3) (NOT AVAILABLE WITH -LDS, -LUX, -P, -K OPTIONS)
- (LEAVE BLANK FOR NO POLARIZATION; AVAILABLE TO EXISTING CUSTOMERS ONLY)

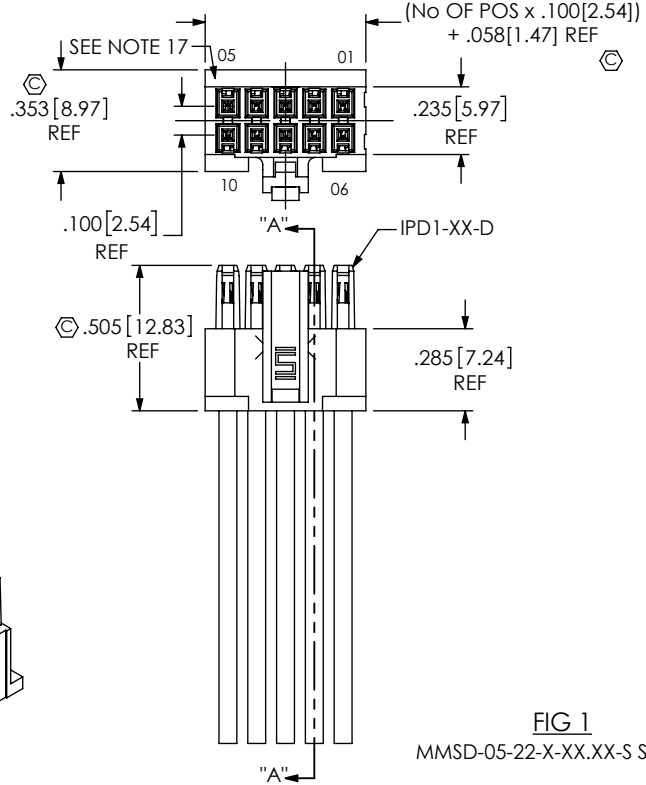
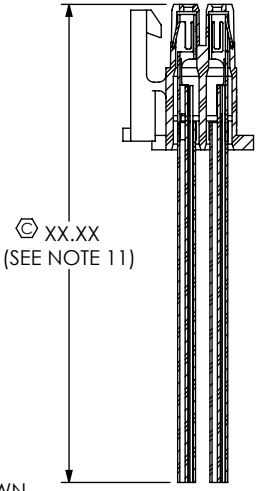

FIG 1
MMSD-05-22-X-XX.XX-S SHOWN



SECTION "A"-"A"

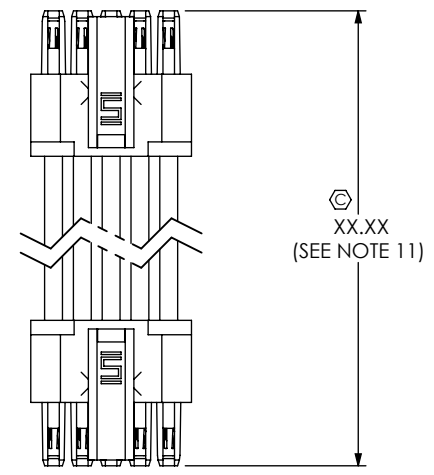
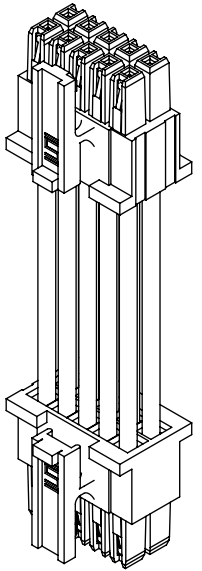

FIG 2
MMSD-05-22-X-XX.XX-D SHOWN



SERIES	WIRE GAUGE	CABLE	CONTACT	"A"
MMSD	20 AWG	DWC-20-XX-300	C-179-03-X	.128 [3.25]
MMSD	22 AWG	DWC-22-XX-300	C-179-03-X	.128 [3.25]
MMSD	24 AWG	DWC-24-XX-300	C-179-03-X	.128 [3.25]
MMSD	26 AWG	DWC-26-XX-300	C-179-02-X	.133 [3.38]
MMSD	28 AWG	DWC-28-XX-300	C-179-02-X	.133 [3.38]
MMSD	30 AWG	DWC-30-XX-300	C-179-02-X	.133 [3.38]
MMSDT	20 AWG	DWCT-20-XX-TC	C-179-03-X	.128 [3.25]
MMSDT	24 AWG	DWCT-24-XX-TC	C-179-03-X	.128 [3.25]
MMSDT	28 AWG	DWCT-28-XX-TC	C-179-04-X	.128 [3.25]
MMSDT	30 AWG	DWCT-30-XX-TC	C-179-04-X	.128 [3.25]

F:\DWG\MISC\MKTG\MMSDX-XX-XXX-X-XX.XX-X-X-XXX-MKT.SLDDRW

UNLESS OTHERWISE SPECIFIED, DIMENSIONS ARE IN INCHES.
TOLERANCES ARE:
DECIMALS ANGLES
.XX: ±.01 [.3] 2°
.XXX: ±.005 [.13]
.XXXX: ±.0020 [.051]

PROPRIETARY NOTE
THIS DOCUMENT CONTAINS CONFIDENTIAL AND PROPRIETARY INFORMATION AND ALL DESIGN, MANUFACTURING, REPRODUCTION, USE, PATENT RIGHTS AND SALES RIGHTS ARE EXPRESSLY RESERVED BY SAMTEC, INC. THIS DOCUMENT SHALL NOT BE DISCLOSED, IN WHOLE OR PART, TO ANY UNAUTHORIZED PERSON OR ENTITY NOR REPRODUCED, TRANSFERRED OR INCORPORATED IN ANY OTHER PROJECT IN ANY MANNER WITHOUT THE EXPRESS WRITTEN CONSENT OF SAMTEC, INC.

520 PARK EAST BLVD, NEW ALBANY, IN 47150
PHONE: 812-944-6733 FAX: 812-948-5047
e-Mail: info@SAMTEC.com code 55322

MATERIAL: DO NOT SCALE DRAWING SHEET SCALE: 1:0.666667
HOUSING: NYLON 66, COLOR: NATURAL
CONTACT: PHOS BRONZE
CABLE: INSULATION: SEE CALLOUT
WIRE: TINNED COPPER
LATCH: NICKEL-PLATED BeCu, #25, 1/2 HT

DESCRIPTION:
.100[2.54] SOCKET DISCRETE CABLE ASSEMBLY
DWG. NO.
MMSDX-XX-XXX-X-XX.XX-X-X-XXX
BY: DEAN P 07/16/2004 SHEET 1 OF 4

REVISION AV

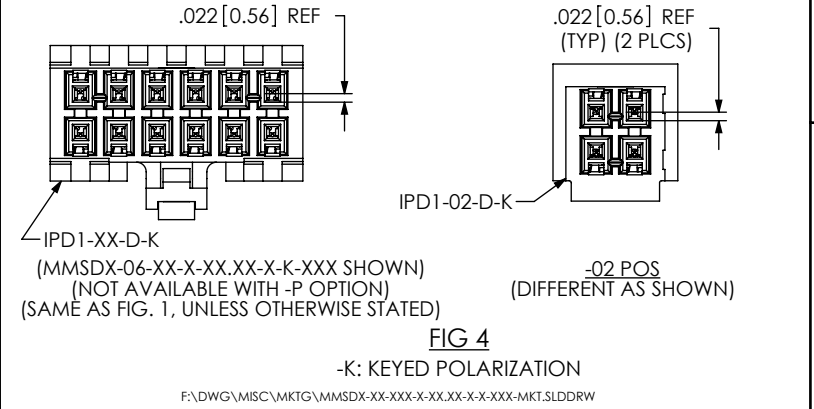
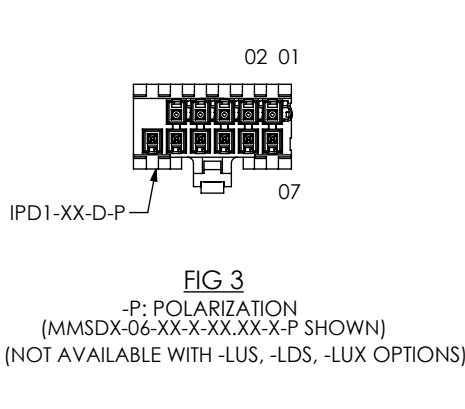
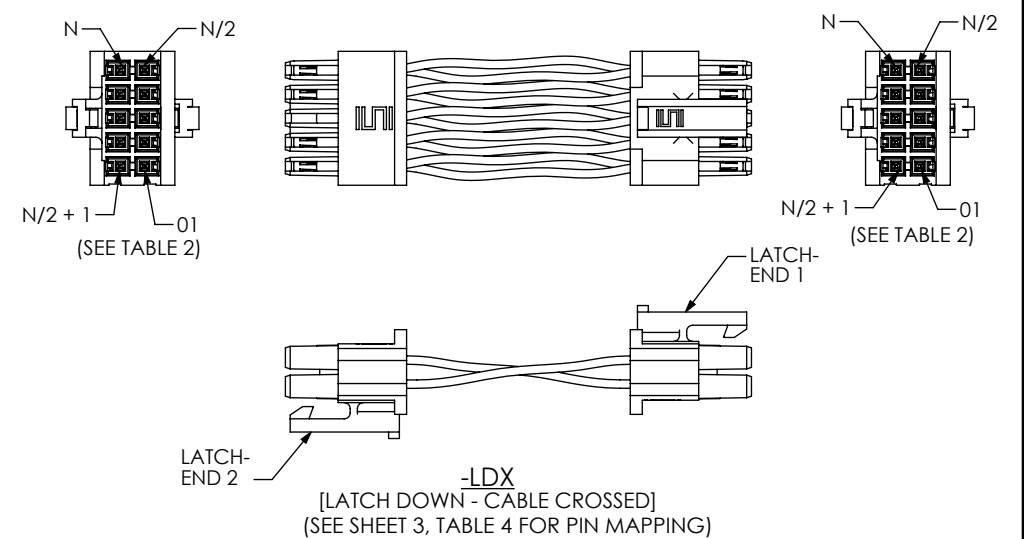
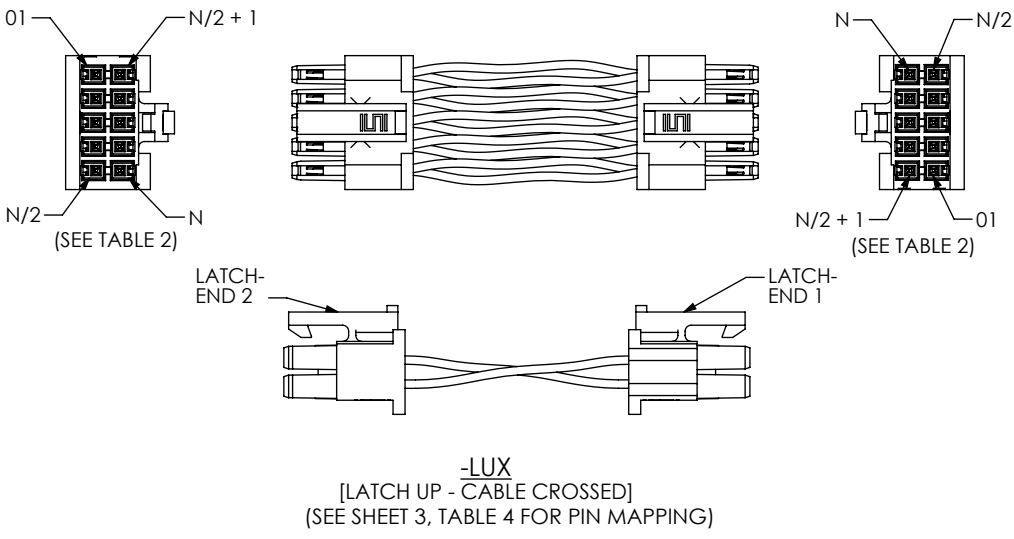
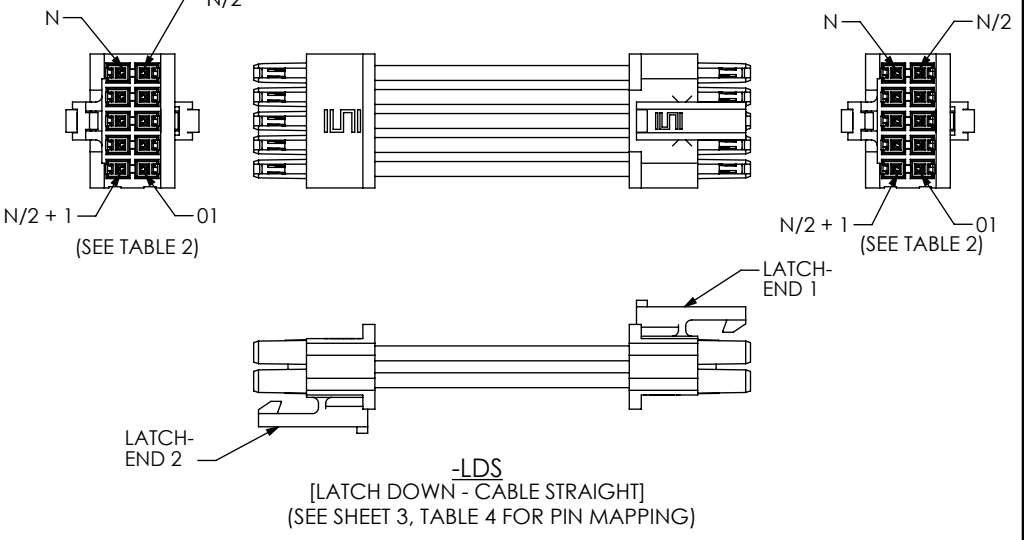
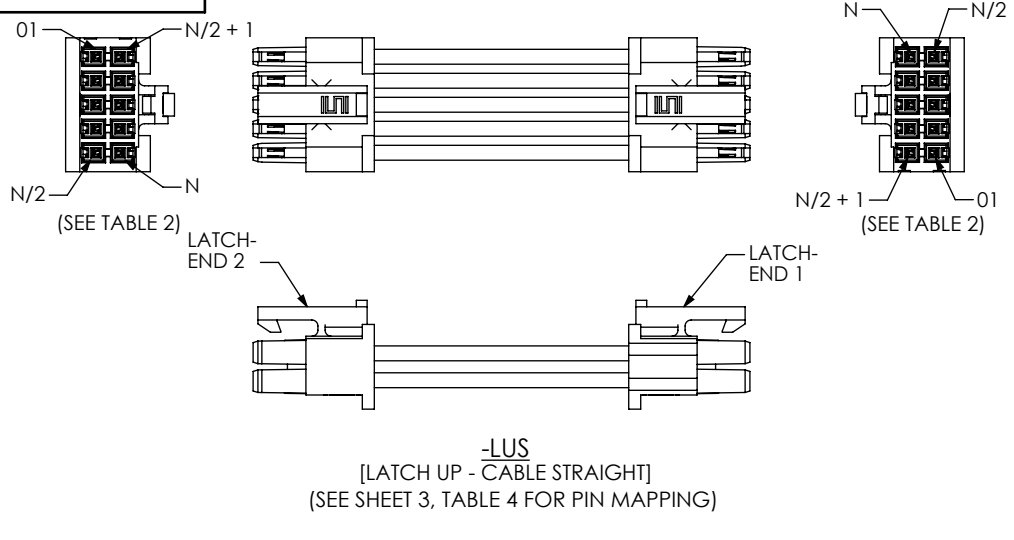

PROPRIETARY NOTE
 THIS DOCUMENT CONTAINS CONFIDENTIAL AND PROPRIETARY INFORMATION AND ALL DESIGN, MANUFACTURING, REPRODUCTION, USE, PATENT RIGHTS AND SALES RIGHTS ARE EXPRESSLY RESERVED BY SAMTEC, INC. THIS DOCUMENT SHALL NOT BE DISCLOSED, IN WHOLE OR PART, TO ANY UNAUTHORIZED PERSON OR ENTITY NOR REPRODUCED, TRANSFERRED OR INCORPORATED IN ANY OTHER PROJECT IN ANY MANNER WITHOUT THE EXPRESS WRITTEN CONSENT OF SAMTEC, INC.

DO NOT SCALE DRAWING
 SHEET SCALE: 1:25:1



520 PARK EAST BLVD, NEW ALBANY, IN 47150
 PHONE: 812-944-6733 FAX: 812-948-5047
 e-Mail: info@SAMTEC.com code 55322

DESCRIPTION:
 .100[2.54] SOCKET DISCRETE CABLE ASSEMBLY

DWG. NO.
MMSDX-XX-XXX-X-XX.XX-X-X-XXX

BY: DEAN P 07/16/2004 SHEET 2 OF 4

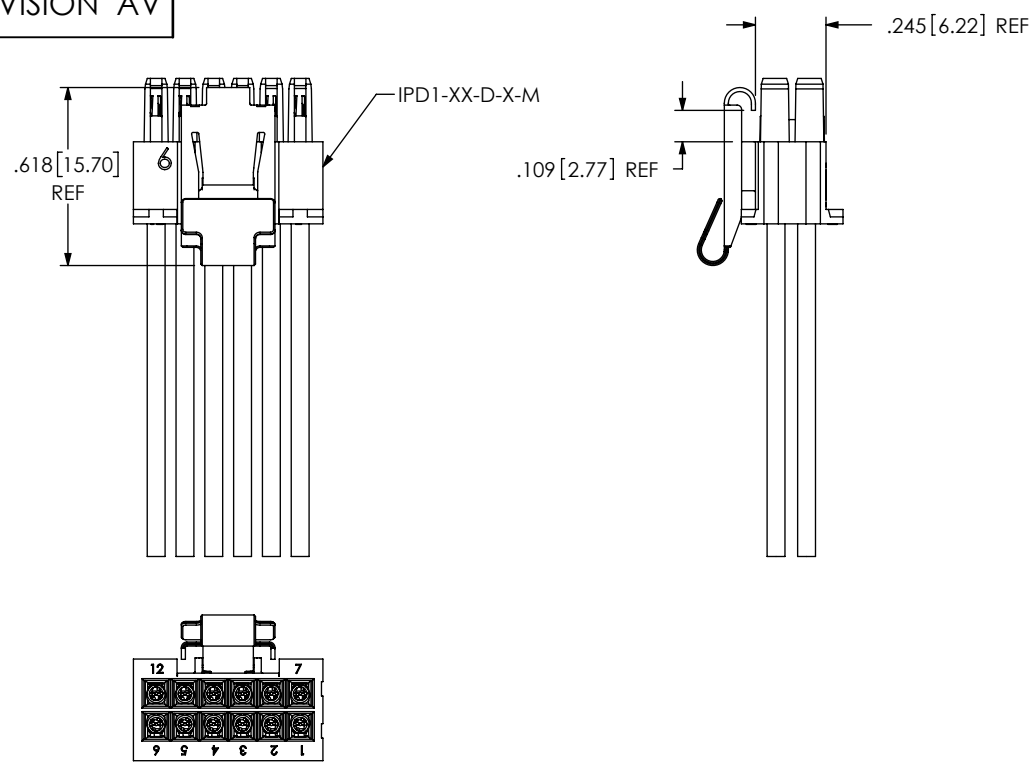

FIG 5
(MMSDX-06-XX-X-XX.XX-S-M SHOWN)
(SAME AS FIG 1, UNLESS OTHERWISE STATED)

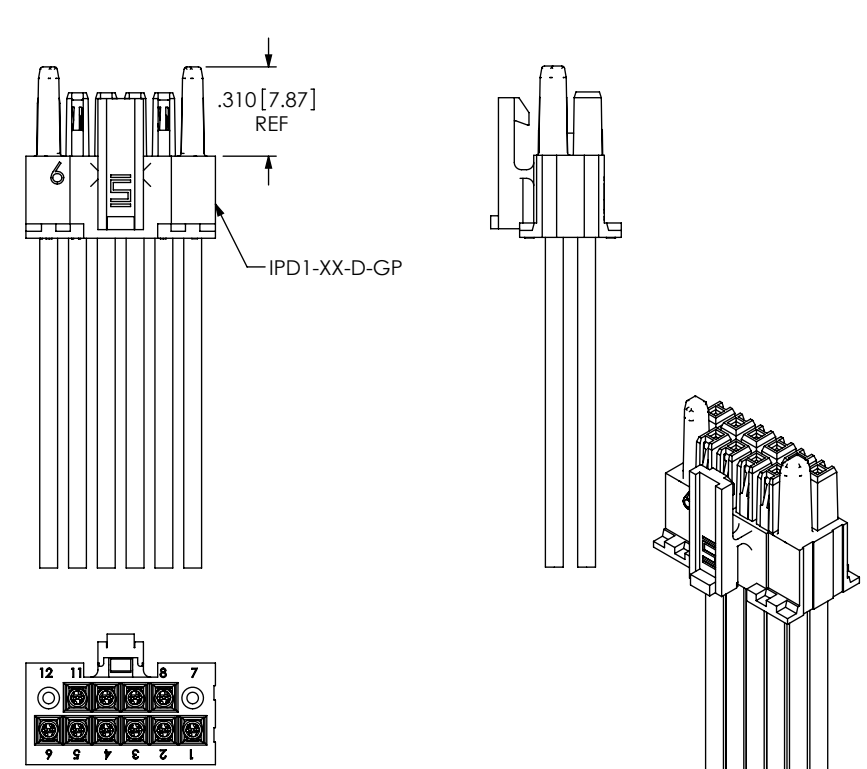

FIG 6
(MMSDX-06-XX-X-XX.XX-S-G SHOWN)
(NOT AVAILABLE WITH -LDS, -LUX, -P, -K OPTIONS)
(SAME AS FIG 1, UNLESS OTHERWISE STATED)

TABLE 3 MMSD COLOR CODED WIRE SEQUENCE										
COLOR										
	BROWN	RED	ORANGE	YELLOW	GREEN	BLUE	VIOLET	GRAY	WHITE	BLACK
	DWC-XX01-300	DWC-XX02-300	DWC-XX03-300	DWC-XX04-300	DWC-XX05-300	DWC-XX13-300	DWC-XX07-300	DWC-XX08-300	DWC-XX09-300	DWC-XX10-300
PIN #	1	2	3	4	5	6	7	8	9	10
	11	12	13	14	15	16	17	18	19	20
	21	22	23	24	25	26	27	28	29	30
	31	32	33	34	35	36	37	38	39	40
	41	42	43	44	45	46	47	48	49	50

Table 4- Pin Mapping		
End Option (Double)	END 1	END 2
-LUS	01	N/2
-LDS	01	N/2+1
-LUX	01	N
-LDX	01	01
-MUS	01	N/2
-MDS	01	N/2+1
-MUX	01	N
-MDX	01	01

TABLE 2			
No. OF POSITIONS	N	N/2	N/2 + 1
-05	10	5	6
-07	14	7	8
-10	20	10	11
-15	30	15	16
-20	40	20	21
-25	50	25	26

PROPRIETARY NOTE
 THIS DOCUMENT CONTAINS CONFIDENTIAL AND PROPRIETARY INFORMATION AND ALL DESIGN, MANUFACTURING, REPRODUCTION, USE, PATENT RIGHTS AND SALES RIGHTS ARE EXPRESSLY RESERVED BY SAMTEC, INC. THIS DOCUMENT SHALL NOT BE DISCLOSED, IN WHOLE OR PART, TO ANY UNAUTHORIZED PERSON OR ENTITY NOR REPRODUCED, TRANSFERRED OR INCORPORATED IN ANY OTHER PROJECT IN ANY MANNER WITHOUT THE EXPRESS WRITTEN CONSENT OF SAMTEC, INC.

DO NOT SCALE DRAWING

SHEET SCALE: 2:1

520 PARK EAST BLVD, NEW ALBANY, IN 47150
 PHONE: 812-944-6733 FAX: 812-948-5047
 e-Mail: info@SAMTEC.com code 55322

DESCRIPTION:
 .100[2.54] SOCKET DISCRETE CABLE ASSEMBLY

DWG. NO.
 MMSDX-XX-XXX-X-XX.XX-X-X-XXX

BY: DEAN P 07/16/2004 SHEET 3 OF 4

CABLE CUT IN-PROCESS

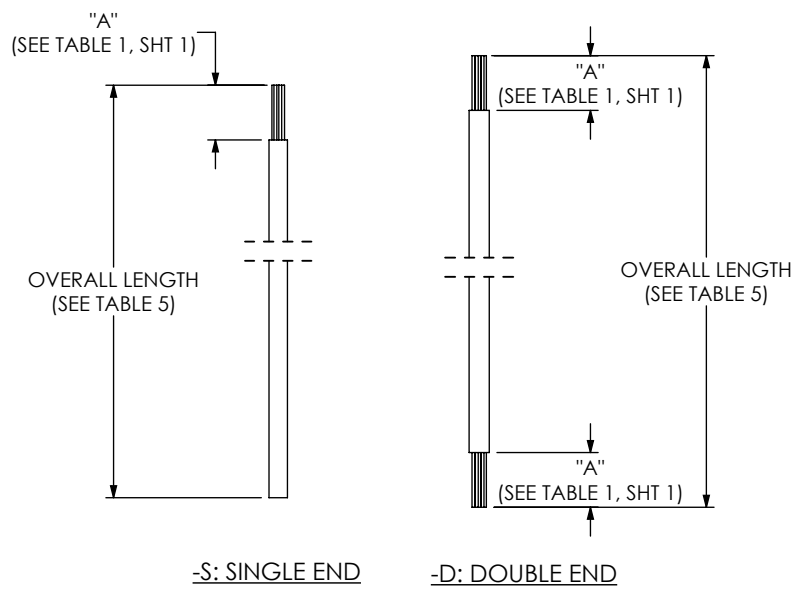

TABLE 5 (OVERALL LENGTH SUBTRACTORS) (SEE NOTE 15)	
	LENGTH
-S: SINGLE END	.250 [6.35]
-D: DOUBLE END	.500 [12.70]

PROPRIETARY NOTE
 * THIS DOCUMENT CONTAINS CONFIDENTIAL AND PROPRIETARY INFORMATION AND ALL DESIGN, MANUFACTURING, REPRODUCTION, USE, PATENT RIGHTS AND SALES RIGHTS ARE EXPRESSLY RESERVED BY SAMTEC, INC. THIS DOCUMENT SHALL NOT BE DISCLOSED, IN WHOLE OR PART, TO ANY UNAUTHORIZED PERSON OR ENTITY NOR REPRODUCED, TRANSFERRED OR INCORPORATED IN ANY OTHER PROJECT IN ANY MANNER WITHOUT THE EXPRESS WRITTEN CONSENT OF SAMTEC, INC. *



520 PARK EAST BLVD, NEW ALBANY, IN 47150
 PHONE: 812-944-6733 FAX: 812-948-5047
 e-Mail info@SAMTEC.com code 55322

SHEET SCALE: 2:1

DESCRIPTION:
 .100[2.54] SOCKET DISCRETE CABLE ASSEMBLY

DWG. NO.
 MMSDX-XX-XXX-X-XX.XX-X-X-XXX

BY: DEAN P 07/16/2004 SHEET 4 OF 4

X-ON Electronics

Largest Supplier of Electrical and Electronic Components

Click to view similar products for [Rectangular Cable Assemblies](#) category:

Click to view products by [Samtec](#) manufacturer:

Other Similar products are found below :

[MC320E-N-23](#) [A08KR08KR26E203B](#) [G125FC10668L0-0300L](#) [G125FC10668L0-0150L](#) [G125-FC11068L0-0150L](#) [G125-FC11068L0-0300L](#)
[A06XAF06XAF22K254B](#) [A16KR16KR26E203B](#) [A12KR12KR26E305A](#) [A12KR12KR26E305B](#) [A12ZR12ZR28H203B](#)
[A12ZR12ZR28H203A](#) [A10SR10SR30K254A](#) [A09SR09SR30K305A](#) [A14KR14KR26E254A](#) [A14KR14KR26E254B](#) [A10ZR10ZR28H254A](#)
[A09ZR09ZR28H305A](#) [A09ZR09ZR28H305B](#) [A13ZR13ZR28H203A](#) [A13KR13KR26E305B](#) [A11ZR11ZR28H254A](#) [A11ZR11ZR28H254B](#)
[A11SR11SR30K254A](#) [A12SUR12SUR32W254A](#) [A10ZR10ZR28H305B](#) [A12ZR12ZR28H254A](#) [A15KR15KR26E305A](#)
[A15KR15KR26E305B](#) [A11SR11SR30K305A](#) [A13ZR13ZR28H254A](#) [A12ZR12ZR28H305A](#) [A12ZR12ZR28H305B](#) [A20XAF20XAF22K51B](#)
[A13ZR13ZR28H305A](#) [A20XAF20XAF22K152B](#) [A20XAF20XAF22K203B](#) [A20XAF20XAF22K254B](#) [A20XAF20XAF22K305B](#)
[A16XSR16XSR36R254B](#) [A02SR02SR30K203B](#) [A06KR06KR26E102A](#) [A02ZR02ZR28H203B](#) [A03SUR03SUR32W102A](#)
[A04ZR04ZR28H102A](#) [A04ZR04ZR28H102B](#) [A03SR03SR30K203B](#) [A02ZR02ZR28H254B](#) [A04SR04SR30K102B](#)
[A02SUR02SUR32W254A](#)