

DO NOT SCALE FROM THIS PRINT

DESIGNED & DIMENSIONED IN INCHES[MILLIMETERS]

PRF92-J-C-EP-085-BS-X

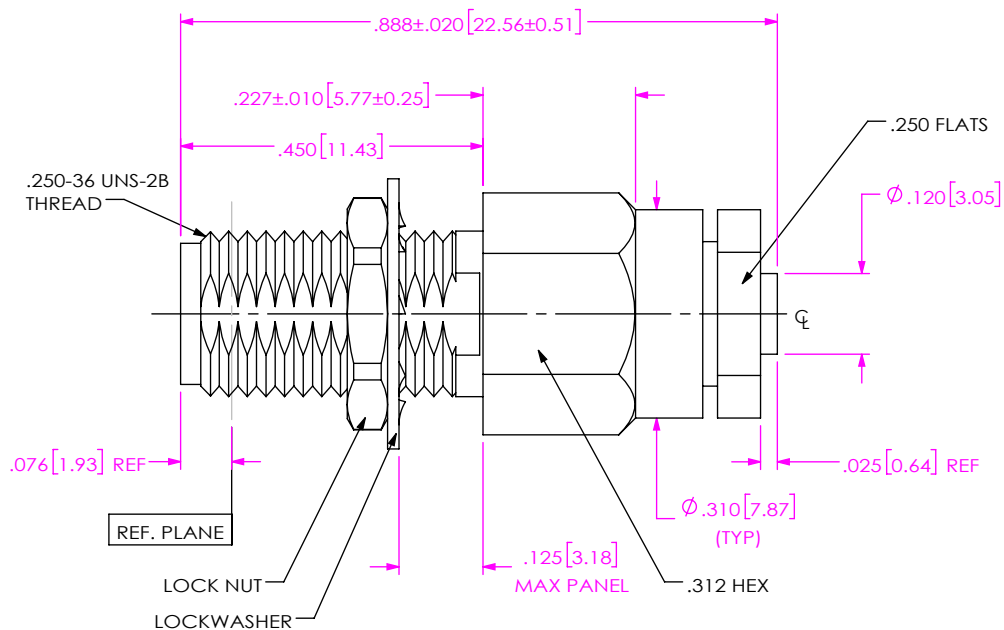

- SERIES
-92: 2.92 MM
- GENDER
-J: JACK
- TYPE
-C: CABLE
- PACKAGING
-B: BULK (IN INCREMENTS OF 50)
(BLANK): STANDARD PACKAGING
- TERMINATION
-S: SOLDER CLAMP
- ORIENTATION
-B: BULKHEAD
- CABLE TYPE
-085: HARBOUR SS405
- PLATING
-EP: 50µ" EXTRA HEAVY GOLD
CENTER CONTACT, PASSIVATED
OUTER CONTACT

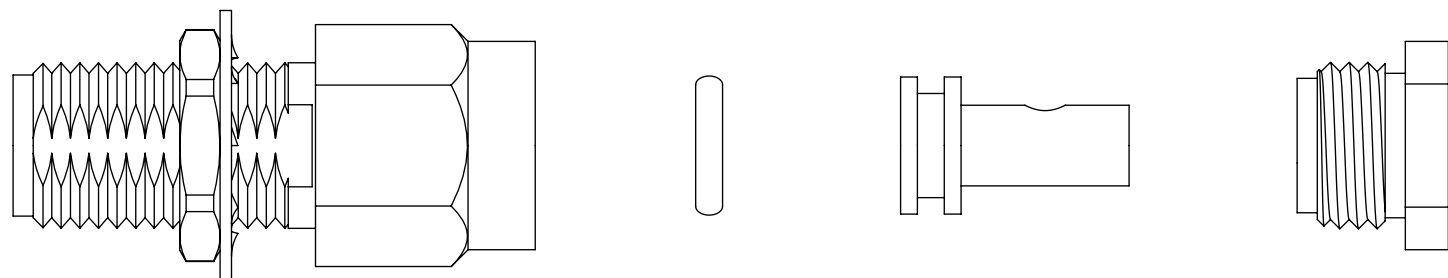
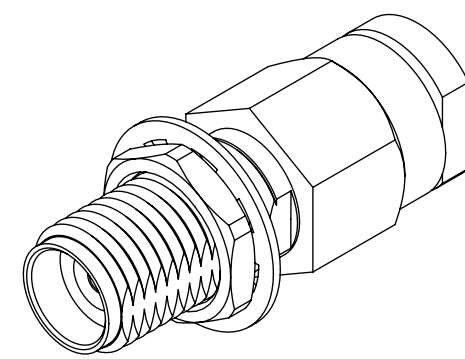

EXPLODED VIEW
NOT TO SCALE
(FOR CLARITY ONLY)

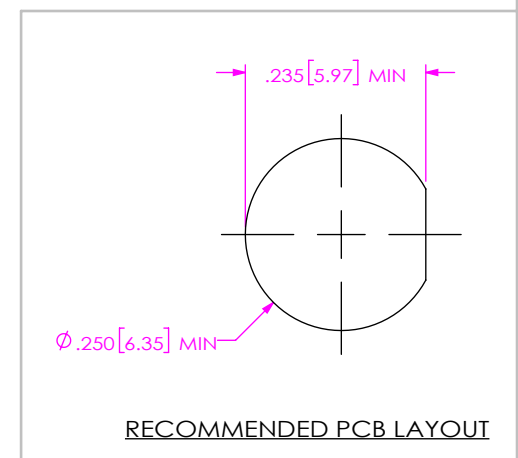

RECOMMENDED PCB LAYOUT

- NOTES:
1. MATERIALS:
BODY, CLAMP NUT, OUTER CONTACT, JAM NUT, LOCK WASHER: STAINLESS STEEL
CONTACT: BERYLLIUM COPPER
SOLDER FERRULE: BRASS ALLOY
BEAD: PCTFE
O-RING: SILICONE RUBBER
 2. FINISH:
BODY, CLAMP NUT, OUTER CONTACT, JAM NUT, LOCK WASHER: PASSIVATED
CONTACT, SOLDER FERRULE: 50µ" GOLD OVER 50µ" NICKEL PLATE
 3. PCI P/N: 3187
 4. BULK PACKAGING OPTION (-B) FOR ORDERS IN INCREMENTS OF 50 PCS.

UNLESS OTHERWISE SPECIFIED, DIMENSIONS ARE IN INCHES. TOLERANCES ARE: DECIMALS ANGLES .XX: ±.01[0.3] 1° .XXX: ±.005[0.13] .XXXX: ±.0005[0.013]	* PROPRIETARY NOTE * THIS DOCUMENT CONTAINS CONFIDENTIAL AND PROPRIETARY INFORMATION AND ALL DESIGN, MANUFACTURING, REPRODUCTION, USE, PATENT RIGHTS AND SALES RIGHTS ARE EXPRESSLY RESERVED BY SAMTEC, INC. THIS DOCUMENT SHALL NOT BE DISCLOSED, IN WHOLE OR PART, TO ANY UNAUTHORIZED PERSON OR ENTITY NOR REPRODUCED, TRANSFERRED OR INCORPORATED IN ANY OTHER PROJECT IN ANY MANNER WITHOUT THE EXPRESS WRITTEN CONSENT OF SAMTEC, INC.	DESCRIPTION: 2.92MM BULKHEAD JACK, SOLDER CLAMP FOR HARBOUR SS405 CABLE
		DWG. NO. PRF92-J-C-EP-085-BS-X BY: HENSON T 04/16/2019 SHEET 1 OF 2

CABLE APPLICATION VIEWS

1A. TRIM CABLE TO EXPOSE DIELECTRIC CORE & BRAID AS SHOWN.
 1B. PRE-TIN EXPOSED BRAID.

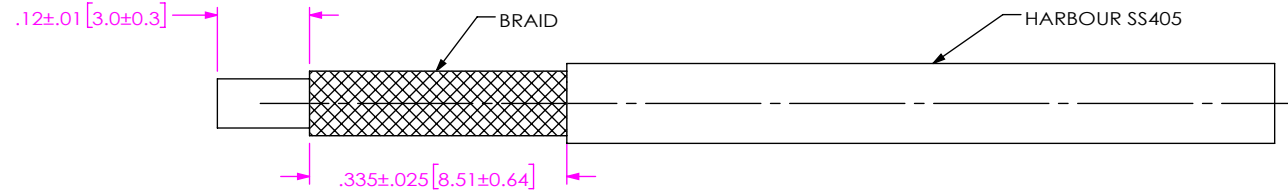

IN-PROCESS VIEW 1

2A: SLIDE CLAMP NUT ONTO CABLE IN ORIENTATION SHOWN.
 2B: INSERT CABLE INTO SOLDER FERRULE UNTIL FULLY SEATED.
 THEN SOLDER CABLE TO FERRULE WHERE SHOWN.
 2C: TRIM CABLE DIELECTRIC FLUSH WITH FERRULE FACE (DO NOT SCORE
 CENTER CONDUCTOR). THEN POINT CENTER CONDUCTOR AS SHOWN

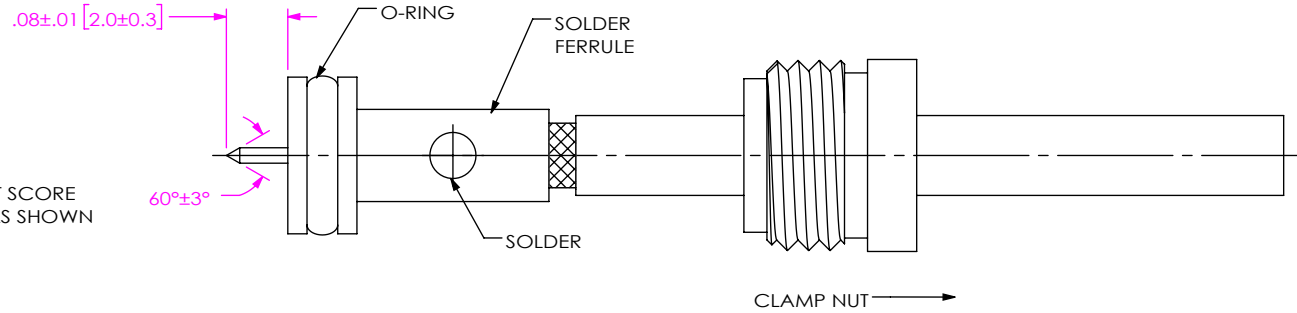

IN-PROCESS VIEW 2

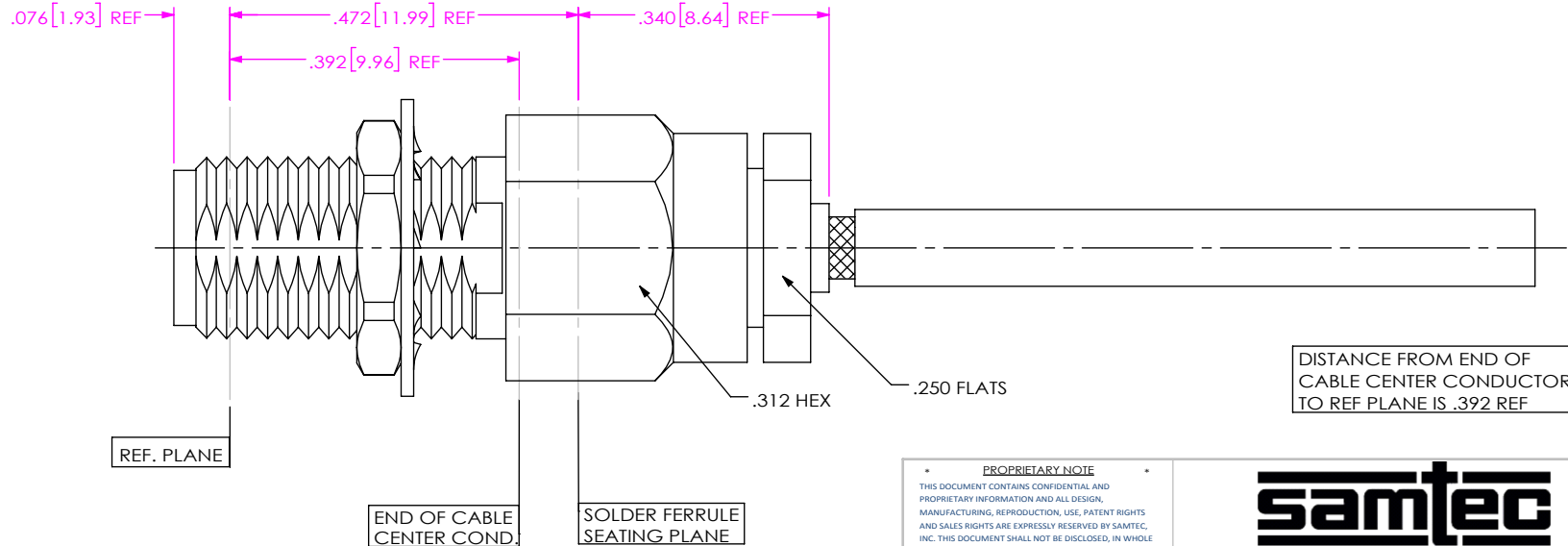

3: INSERT CABLE SUB-ASSEMBLY INTO CONNECTOR
 BODY UNTIL SOLDER FERRULE IS SEATED AND TIGHTEN
 CLAMP NUT TO 25-35 IN. LBS.

IN-PROCESS VIEW 3

PROPRIETARY NOTE
 THIS DOCUMENT CONTAINS CONFIDENTIAL AND
 PROPRIETARY INFORMATION AND ALL DESIGN,
 MANUFACTURING, REPRODUCTION, USE, PATENT RIGHTS
 AND SALES RIGHTS ARE EXPRESSLY RESERVED BY SAMTEC,
 INC. THIS DOCUMENT SHALL NOT BE DISCLOSED, IN WHOLE
 OR PART, TO ANY UNAUTHORIZED PERSON OR ENTITY NOR
 REPRODUCED, TRANSFERRED OR INCORPORATED IN ANY
 OTHER PROJECT IN ANY MANNER WITHOUT THE EXPRESS
 WRITTEN CONSENT OF SAMTEC, INC.



520 PARK EAST BLVD, NEW ALBANY, IN 47150
 PHONE: 812-944-6733 FAX: 812-948-5047
 e-Mail info@SAMTEC.com code 55322

DO NOT SCALE DRAWING

SHEET SCALE: 3:1

DESCRIPTION: 2.92MM BULKHEAD JACK, SOLDER
 CLAMP FOR HARBOUR SS405 CABLE

DWG. NO. PRF92-J-C-EP-085-BS-X

BY: HENSON T 04/16/2019 SHEET 2 OF 2

X-ON Electronics

Largest Supplier of Electrical and Electronic Components

Click to view similar products for [RF Connectors / Coaxial Connectors](#) category:

Click to view products by [Samtec](#) manufacturer:

Other Similar products are found below :

[8915-1511-000](#) [89674-0827](#) [6001-7071-019](#) [6002-7051-003](#) [6002-7551-202](#) [6059674-1](#) [619550-1](#) [630059-000](#) [M39030/3-01N](#) [6500-7071-046](#) [6769](#) [CX050L2AQ](#) [7002-1541-010](#) [7002-1542-011](#) [7004-1512-000](#) [7009-1511-004](#) [7010-1511-000](#) [7029-1511-060](#) [7101-1541-010](#) [7101-1571-002](#) [7145-1521-002](#) [7203-1571-003](#) [7209-1511-011](#) [7210-1511-015](#) [7210-1511-019](#) [73137-5015](#) [73216-2241](#) [73404-2300](#) [7405-1521-005](#) [7405-1521-802](#) [8527](#) [8547](#) [FS11V](#) [877931](#) [8808-1511-001](#) [9074-9513-000](#) [9101-9573-002](#) [910A205F](#) [9130-9573-002](#) [PL11SC-026](#) [PL375-33](#) [PL40-5](#) [PL74C-221](#) [PL75MC-217](#) [PL803-7](#) [1200690078](#) [1-201144-1](#) [R107003010W](#) [R110A172100](#) [R112186000](#)