

# DIODE MODULE (F.R.D.)

# FRS300CA50

UL;E76102 (M)

FRS300CA50 is a high speed (fast recovery) isolated diode module designed for high power switching application. FRS300CA50 is suitable for high frequency application requiring low loss and high speed control.

- High Speed  $t_{rr} \leq 200\text{ns}$
- $I_F (AV)$  300A
- Isolated Mounting base.
- High Surge Capability

### (Applications)

Inverter Welding Power Supply  
Power Supply for Telecommunication  
Various Switching Power Supply.

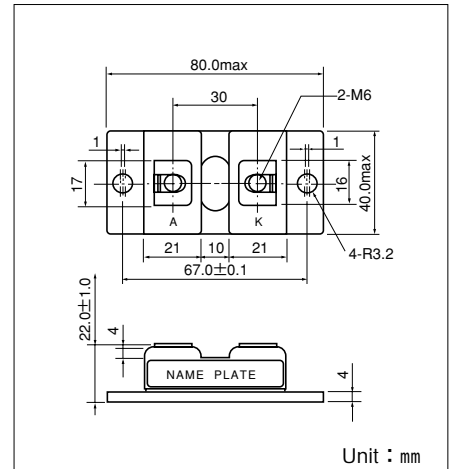

### Maximum Ratings

( $T_j = 25^\circ\text{C}$  unless otherwise specified)

Symbol	Item	Ratings		Unit
		FRS300CA50		
$V_{RRM}$	Repetitive Peak Reverse Voltage	500		V
$V_{R(DC)}$	D.C. Reverse Voltage	400		V

Symbol	Item	Conditions	Ratings	Unit	
$I_F (AV)$	Forward Current	D.C., $T_c : 116^\circ\text{C}$	300	A	
$I_{FMS}$	Surge Forward Current	$1/2$ cycle, 60Hz, peak value, non-repetitive	4000	A	
$I^2t$	$I^2t$	Value for one cycle of surge current	66600	$\text{A}^2\text{S}$	
$T_j$	Operating Junction Temperature		$-40$ to $+150$	$^\circ\text{C}$	
$T_{stg}$	Storage Temperature		$-40$ to $+125$	$^\circ\text{C}$	
$V_{iso}$	Isolation Breakdown Voltage (R.M.S.)	A.C. 1 minute	2500	V	
	Mounting Torque	Mounting (M6)	Recommended Value 2.5-3.9 (25-40)	4.7 (48)	N·m (kgf·cm)
		Terminal (M6)	Recommended Value 2.5-3.9 (25-40)	4.7 (48)	
	Mass	Typical Value	170	g	

### Electrical Characteristics

Symbol	Item	Conditions	Ratings			Unit
			Min.	Typ.	Max.	
$I_{RRM}$	Repetitive Peak Reverse Current	$V_{RRM} = 500\text{V}$ , $T_j = 125^\circ\text{C}$			300	mA
$V_{FM}$	Forward Voltage Drop	$I_F = 300\text{A}$ , Inst. measurement			1.3	V
$t_{rr}$	Reverse Recovery Time	$I_F = 300\text{A}$ , $-di/dt = 300\text{A}/\mu\text{s}$			200	ns
$R_{th(j-c)}$	Thermal Impedance	Junction to case			0.085	$^\circ\text{C}/\text{W}$

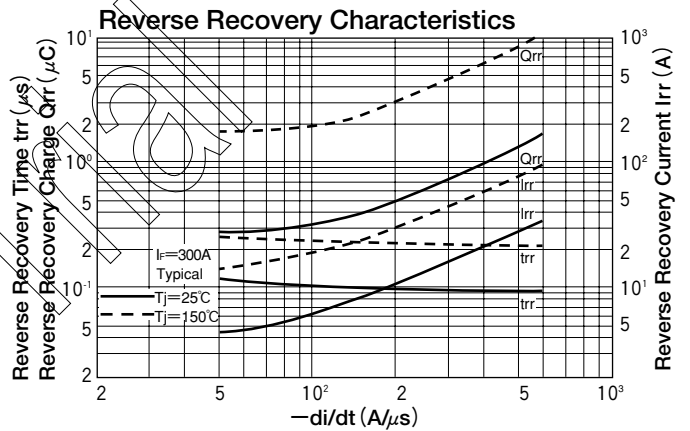
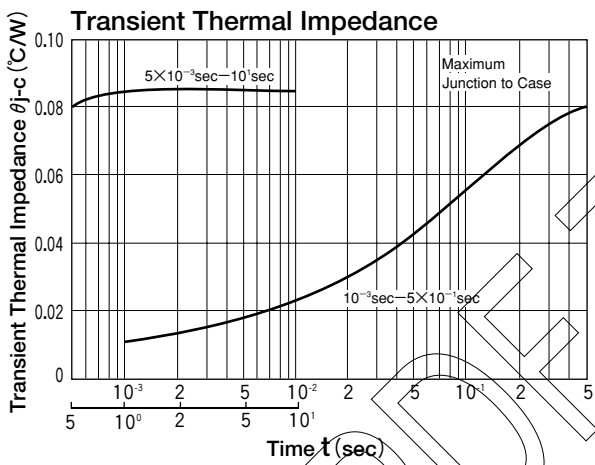
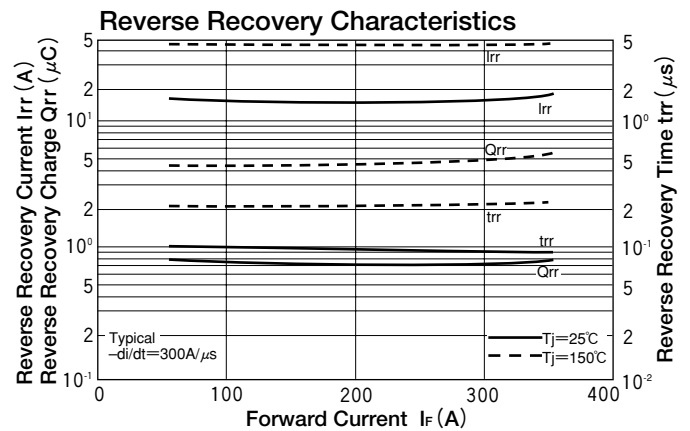
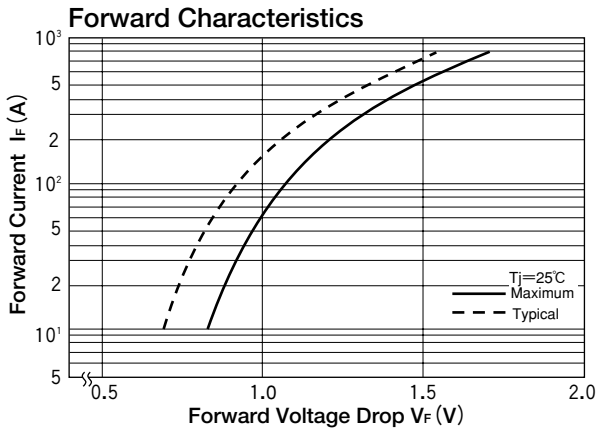

## X-ON Electronics

Largest Supplier of Electrical and Electronic Components

*Click to view similar products for [Discrete Semiconductor Modules](#) category:*

*Click to view products by [Sanrex](#) manufacturer:*

Other Similar products are found below :

[M252511FV](#) [DD260N12K-A](#) [DD380N16A](#) [DD89N1600K-A](#) [APT2X21DC60J](#) [APT58M80J](#) [B522F-2-YEC](#) [MSTC90-16](#) [25.163.0653.1](#)  
[25.163.2453.0](#) [25.163.4253.0](#) [25.190.2053.0](#) [25.194.3453.0](#) [25.320.4853.1](#) [25.320.5253.1](#) [25.326.3253.1](#) [25.326.3553.1](#) [25.330.1653.1](#)  
[25.330.4753.1](#) [25.330.5253.1](#) [25.334.3253.1](#) [25.334.3353.1](#) [25.350.2053.0](#) [25.352.4753.1](#) [25.522.3253.0](#) [T483C](#) [T484C](#) [T485F](#) [T485H](#)  
[T512F-YEB](#) [T513F](#) [T514F](#) [T554](#) [T612FSE](#) [25.161.3453.0](#) [25.179.2253.0](#) [25.194.3253.0](#) [25.325.1253.1](#) [25.326.4253.1](#) [25.330.0953.1](#)  
[25.332.4353.1](#) [25.350.1653.0](#) [25.350.2453.0](#) [25.352.1453.0](#) [25.352.1653.0](#) [25.352.2453.0](#) [25.352.5453.1](#) [25.522.3353.0](#) [25.602.4053.0](#)  
[25.640.5053.0](#)