

### General

- Chip size from 0603 to 2512
- Resistance value from 2mΩ to 200mΩ
- Low thermal EMF
- Low TCR
- Lead free, RoHS compliant for global
- Applications and halogen free

### Application

- Switching model power supply
- Battery pack
- Notebook, personal computer
- Test Instrument
- Power Amplifier

### Electrical Specifications

| Type | Power Rating at 70°C (W) | Resistance Range(mΩ) | TCR (ppm/°C) | Resistance tolerance                   | Operation Temp. Range |
|------|--------------------------|----------------------|--------------|--|-----------------------|
| 0603 | 0.5                      | 3≤R≤9                | ±200         | ±0.5%(D)<br>±1%(F)<br>±2%(G)<br>±5%(J) | -55°C~+170°C          |
|      |                          | 10≤R≤30              | ±100         |  |                       |
| 0805 | 0.5                      | 3≤R≤9                | ±100         |  |                       |
|      | 0.75                     | 10≤R≤47              | ±50          |  |                       |
| 1206 | 0.5                      | 3≤R≤9                | ±100         |  |                       |
|      | 1.0                      | 10≤R≤68              | ±50          |  |                       |
| 2010 | 1.0                      | 3≤R≤9                | ±100         |  |                       |
|      |                          | 10≤R≤100             | ±50          |  |                       |
| 2512 | 1.0<br>2.0*              | 2                    | ±200         |  |                       |
|      |                          | 2.5                  | ±200         |  |                       |
|      |                          | 3≤R≤9                | ±100         |  |                       |
|      |                          | 10≤R≤200             | ±50          |  |                       |

\*: 2512 2W applicable resistance range 2~100mΩ

Remark:

- 0.5 W with total solder pad trace size of 100 mm<sup>2</sup>.
- 0.75 W with total solder pad trace size of 200 mm<sup>2</sup>.
- 1.0 W with total solder pad trace size of 200 mm<sup>2</sup>
- 2.0 W with total solder pad trace size of 300 mm<sup>2</sup>.

### Part Number Information

SMF 25 M 2 E R010 I

【1】 【2】 【3】 【4】 【5】 【6】 【7】

- 【1】 Series Name: SART Metal Foil Type
- 【2】 Chip size:06:0603 08:0805 12:1206 20:2010 25:2512
- 【3】 Material Code: M:Mn-Cu
- 【4】 Power Code: A :0.5W C:0.75W 1:1W 2:2W
- 【5】 Resistance Tolerance: D:±0.5% F:±1% G:±2% J:±5%
- 【6】 Resistance Code:R010=10mΩ 2M50=2.5mΩ
- 【7】 Packaging Code: T: Tape& Reel B: Bulk Pack

### Dimensions

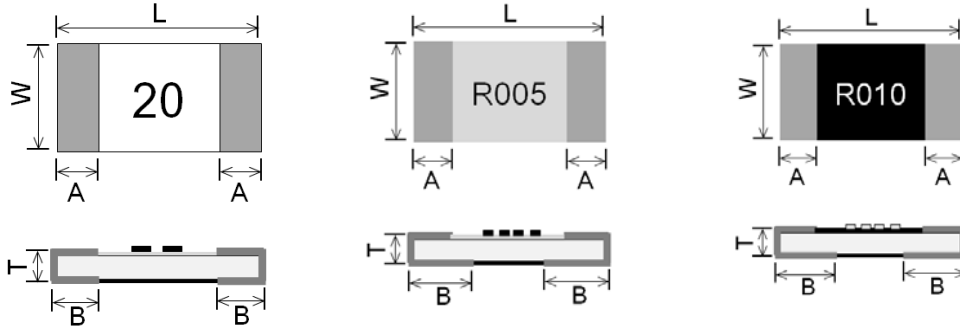

| Type   | Resistance Range(mΩ) | L (mm)    | W (mm)    | T (mm)    | A (mm)    | B (mm)    |
|--------|----------------------|-----------|-----------|-----------|-----------|-----------|
| 0603*  | 3~4                  | 1.60±0.20 | 0.80±0.20 | 0.70±0.15 | 0.35±0.25 | 0.60±0.20 |
|        | ≥5                   |           |           |           |           | 0.35±0.20 |
| 0805** | 3~4                  | 2.00±0.20 | 1.25±0.15 | 0.70±0.15 | 0.40±0.25 | 0.70±0.30 |
|        | ≥5                   |           |           |           |           | 0.40±0.20 |
| 1206   | 3~4                  | 3.20±0.20 | 1.60±0.15 | 0.75±0.15 | 0.50±0.30 | 0.90±0.30 |
|        | ≥5                   |           |           |           |           | 0.50±0.20 |
| 2010   | 3                    | 5.00±0.20 | 2.50±0.20 | 0.75±0.20 | 0.60±0.30 | 1.60±0.30 |
|        | 4~5                  |           |           |           |           | 1.30±0.30 |
|        | ≥6                   |           |           |           |           | 0.80±0.30 |
| 2512   | 2                    | 6.40±0.20 | 3.20±0.20 | 0.75±0.20 | 0.90±0.30 | 2.30±0.30 |
|        | 2.5                  |           |           |           |           | 2.30±0.30 |
|        | 3                    |           |           |           |           | 1.90±0.30 |
|        | 4                    |           |           |           |           | 1.70±0.30 |
|        | 5~6                  |           |           |           |           | 1.20±0.30 |
|        | 7                    |           |           |           |           | 1.10±0.30 |
|        | ≥8                   |           |           |           |           | 0.90±0.30 |

Remark\*: 0603 two-digit mark; \*\*: 0805  $3m\Omega \leq R \leq 9m\Omega$  & 2010 no upper black coating

### Recommended Land Patterns

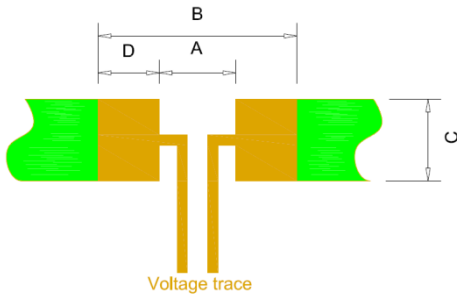

| Type | Resistance Range (mΩ) | A (mm) | B (mm) | C (mm) | D (mm) |
|------|-----------------------|--------|--------|--------|--------|
| 0603 | 3~4                   | 0.40   | 2.80   | 1.00   | 1.20   |
|      | ≥5                    | 0.60   |        |        | 1.10   |
| 0805 | 3~4                   | 0.50   | 3.20   | 1.40   | 1.35   |
|      | ≥5                    | 0.80   |        |        | 1.20   |
| 1206 | 3~4                   | 0.80   | 4.40   | 1.80   | 1.80   |
|      | ≥5                    | 1.80   |        |        | 1.30   |
| 2010 | 3~9                   | 1.60   | 6.30   | 2.90   | 2.35   |
|      | 10~100                | 2.70   |        |        | 1.80   |
| 2512 | 2                     | 1.40   | 8.00   | 3.40   | 3.30   |
|      | 2.5                   | 1.40   |        |        | 3.30   |
|      | 3                     | 2.20   |        |        | 2.90   |
|      | 4                     | 2.60   |        |        | 2.70   |
|      | 5~6                   | 3.60   |        |        | 2.00   |
|      | 7                     | 3.80   |        |        | 2.20   |
|      | ≥8                    | 4.20   |        |        | 1.90   |

### Materials

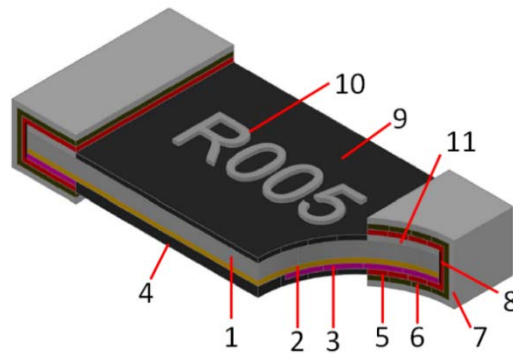

| No. | Materials          | No. | Materials          |
|-----|--------------------|-----|--------------------|
| 1   | Ceramic            | 7   | Tin                |
| 2   | Adhesive film      | 8   | Nicr               |
| 3   | Alloy              | 9   | Protective coating |
| 4   | Protective coating | 10  | Marking            |
| 5   | Copper             | 11  | Silver paste       |
| 6   | Nickel             | /   | /                  |

## Power Derating Curve

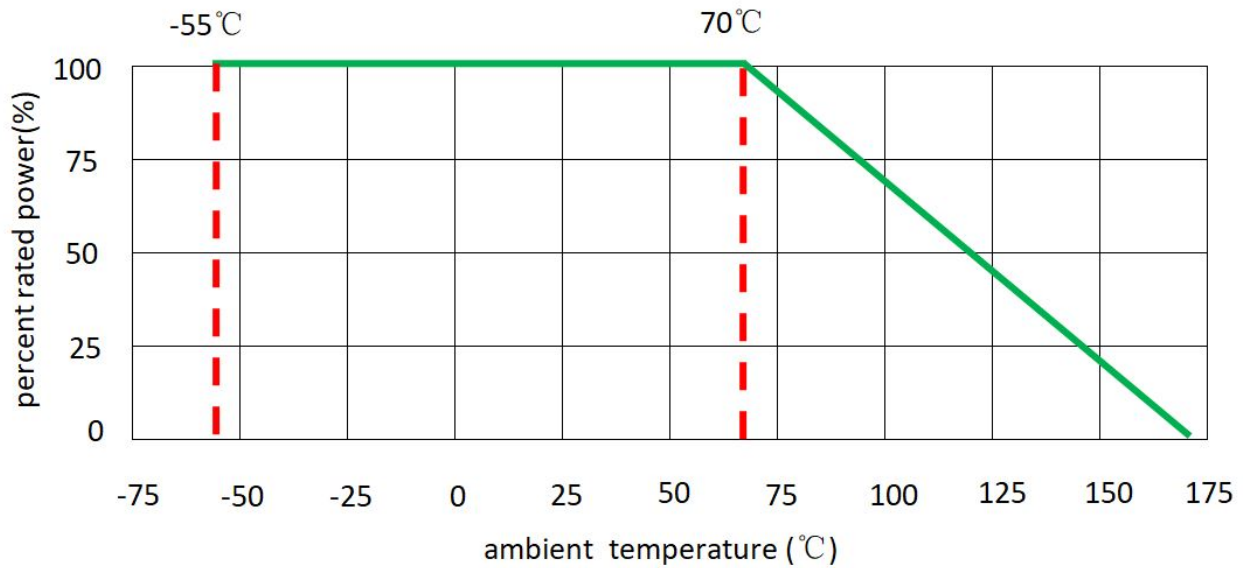

## Recommended Solder Curve

### 1. Infrared Reflow

Temperature: 260°C

Time: 5sec Max.

Recommend Reflow profile:

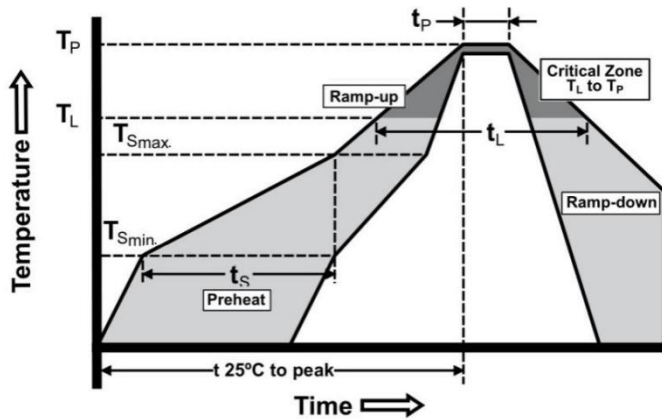

| Profile Feature                                     | Pb-Free Assembly |
|---|------------------|
| Average Ramp-Up Rate ( $T_{Smax}$ to $T_p$ )        | 3°C/sec Max.     |
| Preheat   | 150°C            |
| Temperature Min( $T_{Smin}$ )                       | 200°C            |
| Temperature Max( $T_{Smax}$ )                       | 60sec~120sec     |
| Time( $T_{Smin}$ to $T_{Smax}$ )                    | 260°C            |
| Peak Temperature( $T_p$ )                           | 5sec             |
| Time within 5°C of actual Peak Temperature( $T_p$ ) | 20sec~30sec      |
| Melting tin time( $T_L$ )                           | 6°C/sec Max.     |
| Ramp-Down Rate                                      | 8min Max.        |
| Time 25°C to Peak Temperature                       |                  |

### 2. Wave soldering

Reservoir Temperature : 260°C

Time in Reservoir : 10sec Max.

### 3. Hand Soldering

Temperature : 350°C

Time : 5sec Max.

### Product Characteristics

| Item   | Test condition/ Methods   | Performance               | Standard        |
|--|---|---------------------------|-----------------|
| Short Time Overload                            | 0.5W:5X rated power for 5 sec<br>0.75W:5X rated power for 5 sec<br>1.0W:5X rated power for 5 sec<br>2.0W:4X rated power for 5 sec             | $ \Delta R  \leq \pm 1\%$ | IEC60115-1 4.13 |
| Temperature Coefficient of Resistance (T.C.R.) | $TCR = (R - R_0) / R_0 (T_2 - T_1) \times 10^6$<br>T1 T2<br>Test temperature: 25°C~125°C  | Refer to SART Spec        | IEC60115-1 4.8  |
| Load Life                                      | 1000 hours at rated power, 70°C±2°C,<br>1.5hours "ON", 0.5hours "OFF"   | $ \Delta R  \leq \pm 1\%$ | IEC60115-1 4.25 |
| Bias Humidity                                  | 40°C±2°C, 93% ±3% RH, 1000 hours at rated<br>power, 1.5 hours "ON", 0.5 hours "OFF"   | $ \Delta R  \leq \pm 1\%$ | IEC60115-1 4.24 |
| Thermal Shock                                  | -55°C(30min)/+125°C (30min), 100 cycles   | $ \Delta R  \leq \pm 1\%$ | IEC60115-1 4.19 |
| Solder ability                                 | 245°C±5°C, 3sec ± 0.3sec  | 95%coverage Min.          | IEC60115-1 4.17 |
| Resistance to Soldering Heat                   | 270°C±5°C, 10sec ±1.0sec  | $ \Delta R  \leq \pm 1\%$ | IEC60115-1 4.18 |
| High temperature Exposure                      | 170°C±2°C for 1000 hours  | $ \Delta R  \leq \pm 1\%$ | IEC60115-1 4.23 |
| Bending test                                   | Epoxy thickness1.6mm, Fulcrums distance<br>90mm,Bending width 5mm (0603、0805) ,<br>Bending width 4mm (1206) .Bending width<br>2mm (2010、2512) | $ \Delta R  \leq \pm 1\%$ | IEC60115-1 4.33 |

### Packaging

#### 1. Paper Tape Dimensions

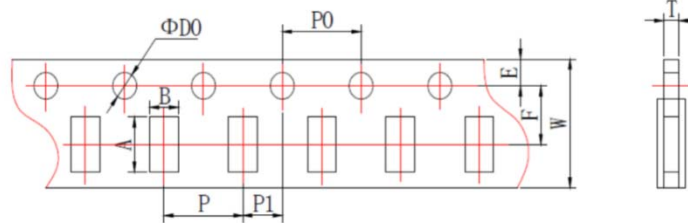

| Type | A (mm)    | B (mm)    | W (mm)    | F (mm)    | E (mm)    |
|------|-----------|-----------|-----------|-----------|-----------|
| 0603 | 1.85±0.10 | 1.10±0.10 | 8.00±0.20 | 3.50±0.05 | 1.75±0.10 |
| 0805 | 2.40±0.10 | 1.60±0.10 | 8.00±0.20 | 3.50±0.05 | 1.75±0.10 |
| 1206 | 3.60±0.20 | 2.00±0.20 | 8.00±0.20 | 3.50±0.05 | 1.75±0.10 |
| Type | P (mm)    | P0 (mm)   | P1 (mm)   | D0 (mm)   | T (mm)    |
| 0603 | 4.00±0.10 | 4.00±0.10 | 2.00±0.05 | 1.50±0.10 | 0.75±0.10 |
| 0805 | 4.00±0.10 | 4.00±0.10 | 2.00±0.05 | 1.50±0.10 | 0.95±0.10 |
| 1206 | 4.00±0.10 | 4.00±0.10 | 2.00±0.05 | 1.50±0.10 | 0.95±0.10 |

#### 2. Embossed Tape Dimensions

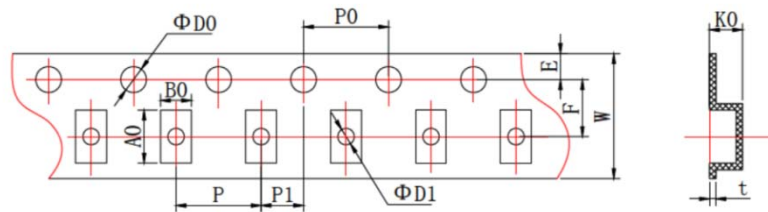

| Type | A0 (mm)   | B0 (mm)   | W (mm)     | F (mm)                             | E (mm)    | T (mm)    |
|------|-----------|-----------|------------|------------------------------------|-----------|-----------|
| 2010 | 5.50±0.15 | 2.80±0.15 | 12.00±0.10 | 5.50±0.10                          | 1.75±0.10 | 0.24±0.05 |
| 2512 | 6.75±0.15 | 3.45±0.15 | 12.00±0.10 | 5.50±0.10                          | 1.75±0.10 | 0.25±0.05 |
| Type | P (mm)    | P0 (mm)   | P1 (mm)    | D0 (mm)                            | D1 (mm)   | K0 (mm)   |
| 2010 | 4.00±0.10 | 4.00±0.10 | 2.00±0.05  | 1.50 <sup>+0.10</sup> <sub>0</sub> | 1.50±0.10 | 0.85±0.05 |
| 2512 | 4.00±0.10 | 4.00±0.10 | 2.00±0.05  | 1.50 <sup>+0.10</sup> <sub>0</sub> | 1.50±0.10 | 1.00±0.10 |

### 3.Reel Dimensions

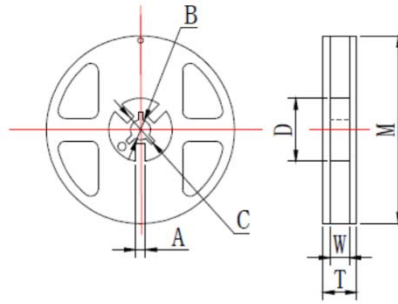

| Type                 | M (mm)      | W (mm)     | T (mm)     | A (mm)    | B (mm)     | C (mm)     | D (mm)     |
|----------------------|-------------|------------|------------|-----------|------------|------------|------------|
| 0603<br>0805<br>1206 | 178.00±2.00 | 9.5±1.00   | 12.50±1.50 | 2.00±0.50 | 13.00±0.50 | 21.00±0.50 | 58.00±0.20 |
| 2010<br>2512         | 178.00±2.00 | 13.00±0.50 | 15.50±1.50 | 2.00±0.50 | 13.00±0.50 | 21.00±0.50 | 57.00±2.00 |

### 4. Quantity of Package

| Type          | 0603 | 0805 | 1206 | 2010 | 2512 |
|---------------|------|------|------|------|------|
| Quantity(PCS) | 5000 |      |      | 4000 |      |

### 5. Peeling Test

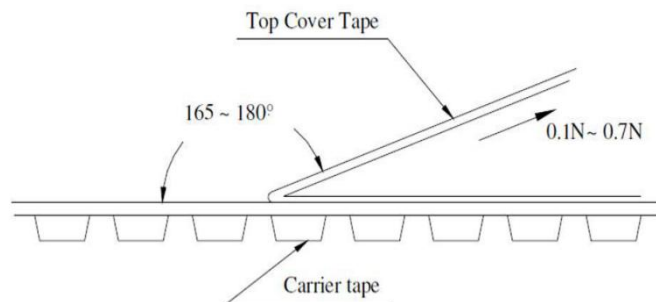

## Storage

- The ambient temperature shall between 5°C~30°C.
- The relative humidity recommended for storage is between 25%RH~60%RH.
- Sealed plastic bags with desiccant shall be used to reduce the oxidation of the termination and shall only be opened prior to use.
- The products shall not be stored in areas where harmful gases containing sulfur or chlorine are present.

## X-ON Electronics

Largest Supplier of Electrical and Electronic Components

*Click to view similar products for [Current Sense Resistors - SMD category](#):*

*Click to view products by [SART manufacturer](#):*

Other Similar products are found below :

[CRL0603-FW-R700ELF](#) [PFS35-200RF1](#) [NPS 2-T126 5.000 OHM 1%](#) [PFS35-0R01J1](#) [PFS35-0R05J1](#) [PFS35-5RF1](#) [CD2015FC-0.10-1%](#)  
[PR2512FKF7W0R004L](#) [RC1005F124CS](#) [RL73K3AR56JTDF](#) [RL7520WT-R001-F](#) [RL7520WT-R009-G](#) [RL7520WT-R020-F](#) [LRC-](#)  
[LR2512LF-01-R820J](#) [WR06X104JGLJ](#) [TL2BR01F](#) [65709-330](#) [SP1R12J](#) [RL7520WT-R039-G](#) [RL7520WT-R002-F](#) [LRF2010-R003JW](#)  
[KRL1632E-C-R200-F-T5](#) [KRL1632E-C-R200-F-T1](#) [Y14880R02000B9R](#) [RLP73M1ER051FTDF](#) [RLP73M2AR075FTDF](#)  
[SR731ERTTP5R10F](#) [SR731ERTTP100J](#) [SR731ERTTP6R80F](#) [SR731ERTTP4R70F](#) [SR731ERTTP2R20F](#) [SR731ERTTP3R90F](#)  
[SR731ERTTP1R00F](#) [SR731ERTTP10R0F](#) [SR731ERTTP2R00F](#) [SR731ERTTP8R20F](#) [SR731ERTTP3R9J](#) [SR731ERTTP8R2J](#)  
[SR731ERTTP2R0J](#) [SR731ERTTP4R7J](#) [SR731ERTTP9R1J](#) [SR731ERTTP1R0J](#) [SR731ERTTP2R2J](#) [SR731ERTTP5R1J](#) [SR731ERTTP6R8J](#)  
[SR731ERTTP9R10F](#) [FCSL64R007JER](#) [LRF1206-R018FW](#) [TLR2B10DR022FTDG](#) [TLR2H10DR01FTDG](#)