



**EN** Operating instructions. . . . . pages 1 to 12  
Original

**6 Diagnostic function**  
6.1 Diagnostic-LEDs . . . . . 8  
6.2 Solenoid interlock with conventional diagnostic output . . . . . 8  
6.3 Solenoid interlock with serial diagnostic function SD . . . . . 9

**7 Set-up and maintenance**  
7.1 Functional testing . . . . . 10  
7.2 Maintenance . . . . . 10

**8 Disassembly and disposal**  
8.1 Disassembly . . . . . 10  
8.2 Disposal . . . . . 10

**9 Appendix**  
9.1 Wiring examples . . . . . 10  
9.2 Wiring configuration and connector accessories . . . . . 11

**10 EU Declaration of conformity**

**Content**

**1 About this document**  
1.1 Function . . . . . 1  
1.2 Target group: authorised qualified personnel . . . . . 1  
1.3 Explanation of the symbols used . . . . . 1  
1.4 Appropriate use . . . . . 1  
1.5 General safety instructions . . . . . 1  
1.6 Warning about misuse . . . . . 2  
1.7 Exclusion of liability . . . . . 2

**2 Product description**  
2.1 Ordering code . . . . . 2  
2.2 Special versions . . . . . 2  
2.3 Comprehensive quality insurance to 2006/42/EC . . . . . 2  
2.4 Purpose . . . . . 2  
2.5 Technical data . . . . . 3  
2.6 Safety classification . . . . . 3

**3 Mounting**  
3.1 General mounting instructions . . . . . 4  
3.2 Manual release . . . . . 5  
3.3 Emergency exit -T/-T8 or emergency release -N . . . . . 5  
3.4 Mounting with mounting plate . . . . . 5  
3.5 Dimensions . . . . . 5  
3.6 Actuator and accessories . . . . . 6

**4 Electrical connection**  
4.1 General information for electrical connection . . . . . 7

**5 Operating principles, coding and latching force adjustment**  
5.1 Magnet control . . . . . 7  
5.2 Mode of operation of the safety outputs . . . . . 7  
5.3 Actuator teaching / actuator detection . . . . . 7  
5.4 Latching force adjustment . . . . . 7

**1. About this document**

**1.1 Function**  
This operating instructions manual provides all the information you need for the mounting, set-up and commissioning to ensure the safe operation and disassembly of the safety switchgear. The operating instructions must be available in a legible condition and a complete version in the vicinity of the device.

**1.2 Target group: authorised qualified personnel**  
All operations described in this operating instructions manual must be carried out by trained specialist personnel, authorised by the plant operator only.

Please make sure that you have read and understood these operating instructions and that you know all applicable legislations regarding occupational safety and accident prevention prior to installation and putting the component into operation.

The machine builder must carefully select the harmonised standards to be complied with as well as other technical specifications for the selection, mounting and integration of the components.

**1.3 Explanation of the symbols used**

 **Information, hint, note:**  
This symbol is used for identifying useful additional information.

 **Caution:** Failure to comply with this warning notice could lead to failures or malfunctions.  
**Warning:** Failure to comply with this warning notice could lead to physical injury and/or damage to the machine.

**1.4 Appropriate use**  
The products described in these operating instructions are developed to execute safety-related functions as part of an entire plant or machine. It is the responsibility of the manufacturer of a machine or plant to ensure the correct functionality of the entire machine or plant.

The safety switchgear must be exclusively used in accordance with the versions listed below or for the applications authorised by the manufacturer. Detailed information regarding the range of applications can be found in the chapter "Product description".

**1.5 General safety instructions**  
The user must observe the safety instructions in this operating instructions manual, the country specific installation standards as well as all prevailing safety regulations and accident prevention rules.



Further technical information can be found in the Schmersal catalogues or in the online catalogue on the Internet: [www.schmersal.net](http://www.schmersal.net).

The information contained in this operating instructions manual is provided without liability and is subject to technical modifications. There are no residual risks, provided that the safety instructions as well as the instructions regarding mounting, commissioning, operation and maintenance are observed.

### 1.6 Warning about misuse



In case of improper use or manipulation of the safety switchgear, personal hazards or damages to machinery or plant components cannot be excluded. The relevant requirements of the standard ISO 14119 must be observed.

### 1.7 Exclusion of liability

We shall accept no liability for damages and malfunctions resulting from defective mounting or failure to comply with this operating instructions manual. The manufacturer shall accept no liability for damages resulting from the use of unauthorised spare parts or accessories.

For safety reasons, invasive work on the device as well as arbitrary repairs, conversions and modifications to the device are strictly forbidden; the manufacturer shall accept no liability for damages resulting from such invasive work, arbitrary repairs, conversions and/or modifications to the device.

## 2. Product description

### 2.1 Ordering code

AZM300<sup>①</sup>-<sup>②</sup>-ST-<sup>③</sup>-<sup>④</sup>-<sup>⑤</sup>

No.	Option	Description
①	Z	Solenoid interlock monitored
	B	Actuator monitored
②		Standard coding
	I1	Individual coding
	I2	Individual coding, re-teaching enabled
③	1P2P	1 p-type diagnostic output and 2 p-type safety outputs
	SD2P	serial diagnostic output and 2 p-type safety outputs
④		Power to unlock
	A	Power to lock
⑤		Manual release
	N	Emergency release
	T	Emergency exit
	T8	Emergency exit, distance 8.5 mm

**Actuator**      **AZ/AZM300-B1**

### 2.2 Special versions

For special versions, which are not listed in the order code below 2.1, these specifications apply accordingly, provided that they correspond to the standard version.

### 2.3 Comprehensive quality insurance to 2006/42/EC

Schmersal is a certified company to appendix X of the Machinery Directive. As a result, Schmersal is entitled to autonomously conduct the conformity assessment procedure for the products listed in Appendix IV of the MD without involving a notified body. The prototype test certificates are available upon request or can be downloaded from the Internet at [www.schmersal.com](http://www.schmersal.com).

### 2.4 Purpose

The non-contact, electronic safety switchgear is designed for application in safety circuits and is used for monitoring the position and locking of movable safety guards.



The safety switchgears are classified according to ISO 14119 as type 4 interlocking devices. Designs with individual coding are classified as highly coded.

The different variants can be used as safety switch with interlocking function either as solenoid interlock.



If the risk analysis indicates the use of a monitored interlock then a variant with the monitored interlock is to be used, labelled with the symbol.

The actuator monitoring variant (B) is a safety switch with an interlock function for process protection.

The safety function consists of safely switching off the safety outputs when the safety guard is opened and maintaining the safe switched off condition of the safety outputs for as long as the safety guard is open.



Interlocks with power to lock principle may only be used in special cases after a thorough evaluation of the accident risk, since the safety guard can be opened immediately on failure of the power supply or upon activation of the main switch.

### Emergency exit (-T/-T8)



Fitting and actuation only from within the hazardous area.

To activate the emergency exit, turn the red lever in the direction of the arrow to the end stop. The safety outputs switch off and the guard system can be opened. The blocked position is cancelled by turning the lever in the opposite direction. In the unlocked position, the guard system is secured against unintentional locking.

### Emergency release (-N)



Mounting and actuation only outside of the safety guard.

To activate the emergency release turn the red lever in the direction of the arrow to the end stop. The safety outputs switch off and the guard system can be opened. The lever is latched and cannot be returned to its original position. To cancel the blocking condition, the central mounting screw must be loosened to such extent that the lever can be turned back into its original position. The screw must then be re-tightened.

### Series wiring

Series-wiring can be set up. The response and risk times are not altered by wiring in series. The number of components is only limited by the external cable protection according to the technical data and the line loss. Series-wiring of up to 31 AZM300 ... SD components with serial diagnostics is possible. In devices with the serial diagnostics function (ordering suffix -SD), the serial diagnostics connections are wired in series and connected to a SD Gateway for evaluation purposes. Wiring examples for series-wiring, refer to appendix.



The user must evaluate and design the safety chain in accordance with the relevant standards and the required safety level. If multiple safety sensors are involved in the same safety function, the PFH values of the individual components must be added.



The entire concept of the control system, in which the safety component is integrated, must be validated to the relevant standards.

### 2.5 Technical data

Standards:	IEC 60947-5-1, IEC 60947-5-3, ISO 14119, ISO 13849-1, IEC 61508, IEC 62061
Enclosure:	glass-fibre reinforced thermoplastic, self-extinguishing
Active principle:	RFID
Frequency band:	125 kHz
Transmitter output:	max. -6 dBm
Coding level according to ISO 14119:	
- I1-version:	high
- I2-version:	high
- Standard coding version:	low
Reaction time:	
- Actuator:	≤ 100 ms
- Inputs:	≤ 0.5 ms
Duration of risk:	≤ 200 ms
Time to readiness:	≤ 5 s
Actuator:	AZ/AZM300-B1
Series-wiring:	Unlimited number of components, please observe external cable protection, max. 31 components in case of serial diagnostics
Length of the sensor chain:	max. 200 m

### Mechanical data

Connection:	Connector plug M12, 8-pole, A-coded
Mechanical life:	≥ 1,000,000 operations
- when used as door stop:	≥ 50,000 operations for safety guards ≤ 5 kg and actuating speed ≤ 0.5 m/s

Angular misalignment between solenoid interlock and actuator:	≤ 2°
Fixing screws:	2x M6
Tightening torque of the fixing screws:	6 ... 7 Nm
Latching force:	25 N / 50 N
Holding force $F_{max}$ :	1,500 N
Holding force $F_{zh}$ :	1,150 N

### Switching distances to IEC 60947-5-3:

Typical switching distance $s_n$ :	2 mm
Assured switching distance $s_{ao}$ :	1 mm
Assured switch-off distance $s_{ar}$ :	20 mm

### Ambient conditions

Ambient temperature:	0 °C ... +60 °C
Storage and transport temperature:	-10 °C...+90 °C
Protection class:	IP66, IP67, IP69 to IEC 60529
Protection class:	III
Resistance to shock:	30 g / 11 ms
Resistance to vibration:	10 ... 150 Hz, Amplitude 0.35 mm
Insulation values to IEC 60664-1:	
- Rated insulation voltage $U_i$ :	32 VDC
- Rated impulse withstand voltage $U_{imp}$ :	0.8 kV
- Over-voltage category:	III
- Degree of pollution:	3
Switching frequency:	0.5 Hz

### Electrical data

Operating voltage $U_B$ :	24 VDC -15 % / +10 % (stabilised PELV - power supply)
Power consumption device:	< 0.1 A
Operating current device with magnet switched on:	
- Peak current:	< 0.35 A / 200 ms
- Averaged:	< 0.2 A
Required rated short-circuit current:	100 A
External Device fuse rating:	2 A (T)

### Electrical data – Safety inputs

Safety inputs:	X1 and X2
Switching thresholds:	- 3 V ... 5 V (Low), 15 V ... 30 V (High)

Power consumption per input:	≤ 5 mA / 24 V
Accepted test pulse duration on input signal:	≤ 1.0 ms
- With test pulse interval of:	≥ 100 ms
Classification:	ZVEI CB241

Countersink:	C1	Source:	C1	C2	C3
--------------	----	---------	----	----	----

### Electrical data – Safety outputs

Safety outputs:	Y1 and Y2
Switching elements:	p-type, short-circuit proof
Utilisation category:	DC-12: $U_g/I_g$ : 24 VDC / 0.25 A DC-13: $U_g/I_g$ : 24 VDC / 0.25 A

Rated operating current $I_g$ :	0.25 A
Leakage current $I_r$ :	≤ 0.5 mA
Voltage drop $U_g$ :	≤ 4 V
Cross-wire monitoring by device:	Yes
Test pulse duration:	≤ 0.3 ms
Test pulse interval:	1,000 ms
Classification:	ZVEI CB241

Source:	C2	Countersink:	C1	C2
---------	----	--------------	----	----

### Electrical data – Diagnostic output

Diagnostic output:	OUT
Switching element:	p-type, short-circuit proof
Utilisation category:	DC-12: $U_g/I_g$ : 24 VDC / 0.05 A DC-13: $U_g/I_g$ : 24 VDC / 0.05 A

Rated operating current $I_g$ :	0.05 A
Voltage drop $U_g$ :	≤ 4 V

### Serial diagnostic SD

Operating current:	0.15 A
Wiring capacitance:	max. 50 nF

### Electrical data – Magnet control

Solenoid input:	IN
Switching thresholds:	- 3 V ... 5 V (Low), 5 V ... 30 V (High)

Power consumption:	10 mA / 24 V
Magnet switch-on time ED:	100 %
Accepted test pulse duration on input signal:	≤ 5.0 ms
- With test pulse interval of:	≥ 40 ms
Classification:	ZVEI CB241

Countersink:	C0	Source:	C1	C2	C3
--------------	----	---------	----	----	----

### LED status display

green LED:	Supply voltage
yellow LED:	Device condition
red LED:	Fault



This device is intended to be powered by a Listed Limited Voltage, Limited Current or Class 2 source. This device shall be powered with the use of a Listed (CYJV) cable/connector assembly rated 24 Vdc, 0.8 A minimum.

### 2.6 Safety classification

#### - of the interlocking function:

Standards:	ISO 13849-1, IEC 61508, IEC 62061
PL:	e
Control Category:	4
PFH:	$5.2 \times 10^{-10}$ / h
PFD:	$4.5 \times 10^{-5}$
SIL:	suitable for SIL 3 applications
Service life:	20 years

#### - of the guard locking function:

Standards:	ISO 13849-1, IEC 61508, IEC 62061
PL:	d
Control Category:	2
PFH:	$2.0 \times 10^{-9}$ / h
PFD:	$1.8 \times 10^{-4}$
SIL:	suitable for SIL 2 applications
Service life:	20 years



The safety consideration of the guard locking function only applies for standard devices with monitored solenoid interlock AZM300Z-...-1P2P-... (see Ordering code).



The actuation of the interlock must be compared with the external OSSD enabler. If a shut-down now occurs due to an unintentional unlocking this is detected by an external diagnostic.



If for a certain application the quiescent current version of a solenoid interlock cannot be used, then for this exception an interlock with power to lock can be used if additional safety measure need to be realised that have an equivalent safety level.



The safety analysis of the guard locking function refers to the component solenoid interlock AZM as part of the complete system.  
On the customer side further measures such as safe actuation and safe cable installation to prevent faults are to be implemented.  
In the event of a fault resulting in the unlocking of the guard locking, this is detected by the solenoid interlock and the safety gates Y1/Y2 switch off. When such a fault occurs the protection equipment may open immediately, just once, before the safe condition of the machine is reached. The system reaction of category 2 allows that a fault can occur between tests causing the loss of the safety function which is detected by the test.

### 3. Mounting

#### 3.1 General mounting instructions



Please observe the relevant requirements of the standards ISO 12100, ISO 14119 and ISO 14120.



The safety component and the actuator must be permanently fitted to the safety guards and protected against displacement by suitable measures (tamperproof screws, gluing, drilling, pinning).

For the correct fixing of the solenoid interlock and the actuator, two mounting holes for M6 screws are provided (tightening torque: 6 ... 7 Nm).

Any mounting position. The system must only be operated with an angle of  $\leq 2^\circ$  between the solenoid interlock and the actuator.

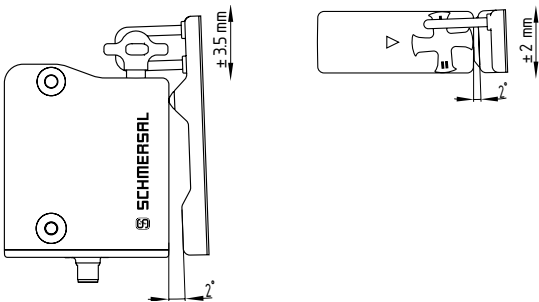

The solenoid interlock can be used as an end stop. Dependant upon the door weight and the actuating speed, the mechanical life could be reduced.

#### Mounting of the solenoid interlock and the actuator

Refer to the mounting instructions manual for the corresponding actuator.

#### Actuating directions

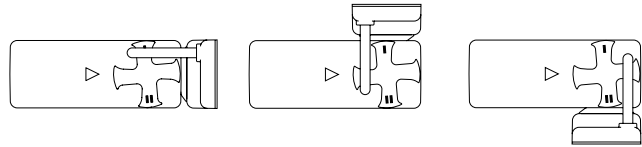

The diagrams show a closed guard system with a set latching force of 50 N (for adjustment of latching force, see chapter 5.4).



Provide for a sufficient insertion of the actuator into the rotary handle.

Correct

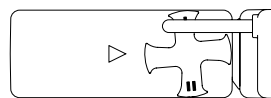

False

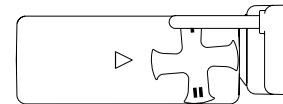

To avoid any interference inherent to this kind of system and any reduction of the switching distances, please observe the following guidelines:

- The presence of metal chips in the vicinity of the solenoid interlock is liable to modify the switching distance.
- Keep away from metal chips.

#### Minimum distance between two solenoid interlocks

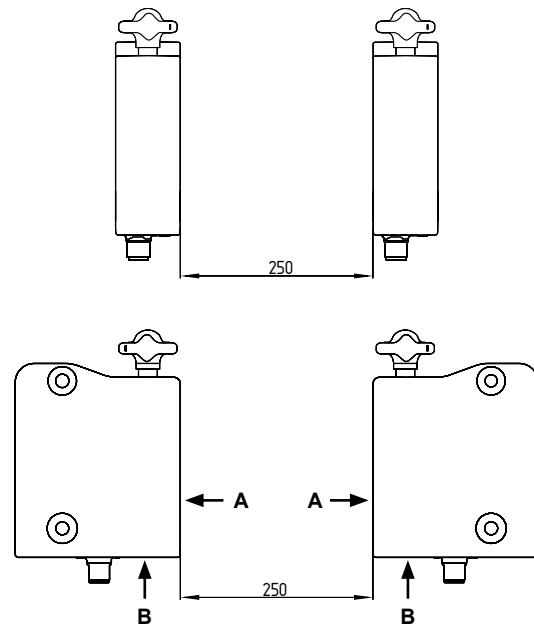

as well as other systems with same frequency (125 kHz)

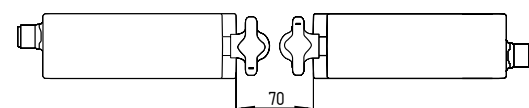
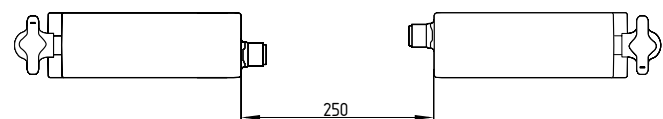

The minimum distance from metallic securing surfaces to the face side "A" and underside "B" of the device is 5 mm.



### 3.2 Manual release

For the machine set-up, the solenoid interlock can be unlocked in a de-energised condition. The solenoid interlock is unlocked by turning the manual release in the position . The normal locking function is only restored after the manual release has been returned to its original position .

**Caution: do not turn beyond the end stop!**

After being put into operation, the manual release must be sealed by means of the seal, which is included in delivery.

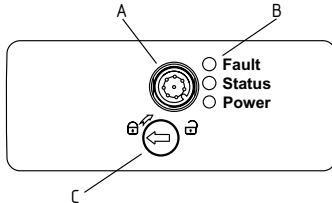

#### Key

- A: connector plug M12, 8-pole
- B: LED indications
- C: Manual release

### 3.3 Emergency exit -T/-T8 or emergency release -N

With variants that have both emergency exit and emergency release, the red lever is loosely supplied. The lever should be fastened to the position intended with the supplied screws before first being used. The lever should be installed on the unlocking triangle in such a way that the arrow on the triangle and the lever pivot are congruent. The installation of the lever is possible on both sides. The opposite is to be sealed with the seal included with delivery.

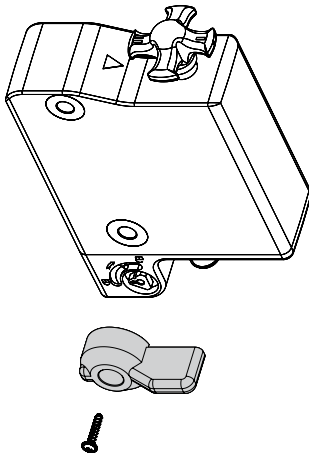

#### Emergency exit (-T/-T8)

Fitting and actuation only from within the hazardous area.



#### Emergency release (-N)

Mounting and actuation only outside of the safety guard.

The emergency release should only be used in an emergency. The solenoid interlock should be installed and/or protected so that an inadvertent opening of the interlock by an emergency release can be prevented.

The emergency release must be clearly labelled that it should only be used in an emergency. The label can be used that was included in the delivery.



To ensure correct operation of emergency exit -T/-T8 and emergency release -N, the safety door/guard must not be in a mechanically tensioned state.

### 3.4 Mounting with mounting plate

For doors, which close flush with the door frame, the optional mounting late MP-AZ/AZM300-1 can be used.

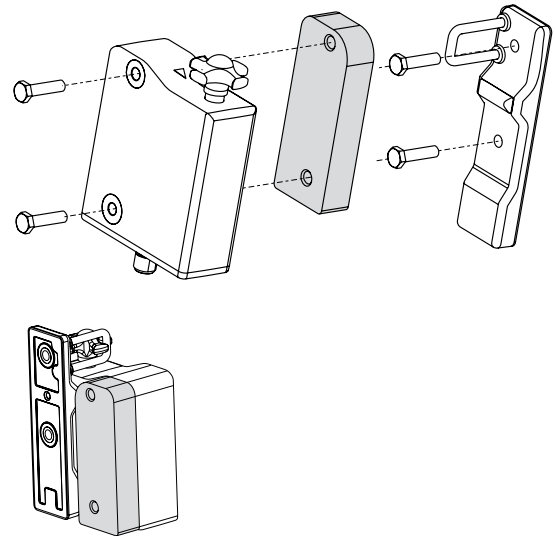

### 3.5 Dimensions

All measurements in mm.

#### AZM300

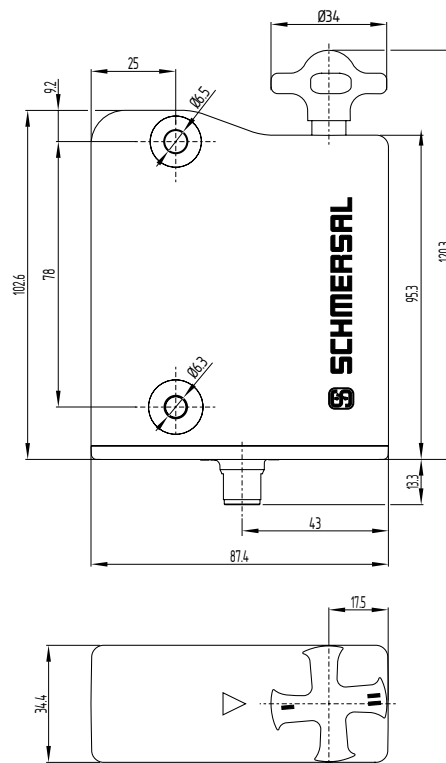

## AZM300...-T/-T8 and -N

Device with emergency exit or emergency release

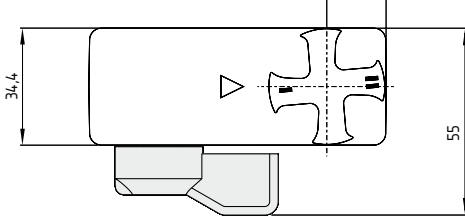
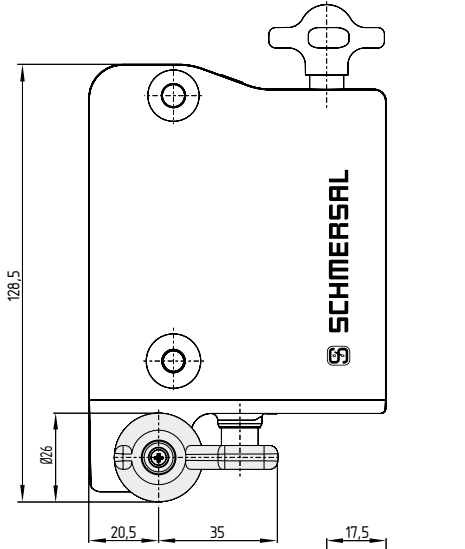

Emergency exit -T

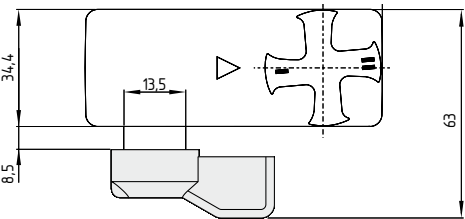

Emergency exit -T8

## 3.6 Actuator and accessories

Actuator AZ/AZM300-B1 (not included in delivery)

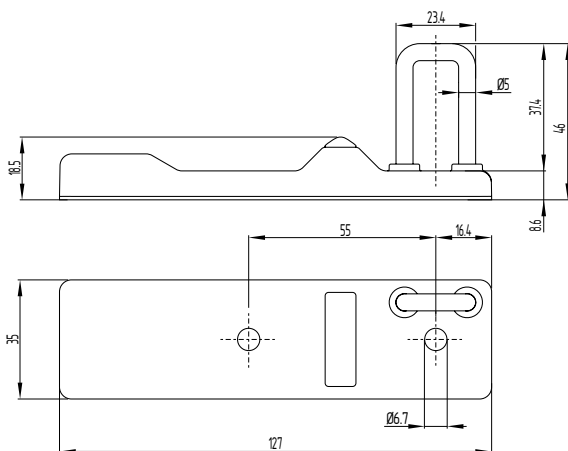

## Mounting plate MP-AZ/AZM300-1 (available as accessory)

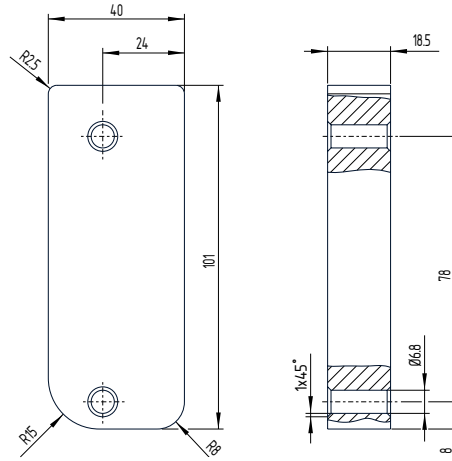

## Lockout tag SZ 200-1 (available as accessory)

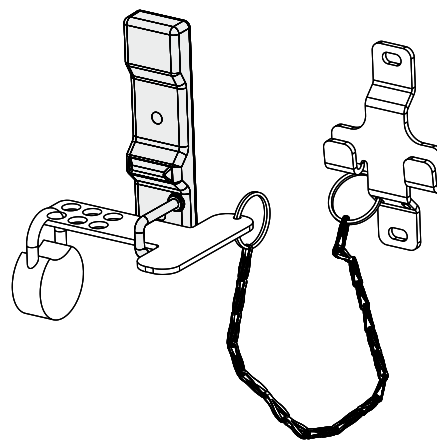
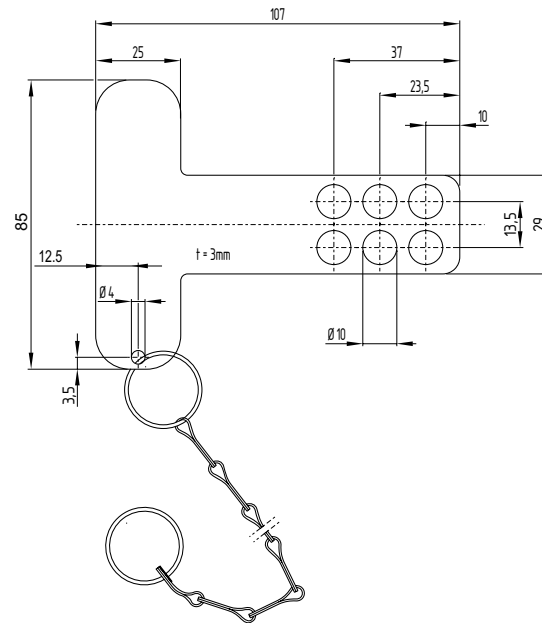



### 4. Electrical connection

#### 4.1 General information for electrical connection



The electrical connection may only be carried out by authorised personnel in a de-energised condition.

The voltage inputs A1, X1, X2 and IN must have a protection against permanent overvoltage. Supply units according to IEC 60204-1 is recommended.

The safety outputs can be integrated in the safety circuit of the control system.

#### Requirements for the connected safety-monitoring module:

- Dual-channel safety input, suitable for p-type semi-conductor outputs



#### Configuration of the safety-monitoring module

If the safety sensor is connected to electronic safety-monitoring modules, we recommend that you set a discrepancy time of min. 100 ms. The safety inputs of the safety-monitoring module must be able to blank a test impulse of approx. 1 ms. The safety-monitoring module does not need to have a cross-wire short monitoring function, if necessary, the cross-wire short monitoring function must be disabled.



Information for the selection of suitable safety-monitoring modules can be found in the Schmersal catalogues or in the online catalogue on the Internet: [www.schmersal.net](http://www.schmersal.net).

#### Cable design in case of serial diagnostics



When wiring SD devices, please observe the voltage drop on the cables and the current carrying capacity of the individual components.

The wiring capacity of the connecting cable of the solenoid interlock must not exceed 50 nF. Depending on the strand structure, normal unshielded 30 m long control cables LIYY 0.25 mm<sup>2</sup> to 1.5 mm<sup>2</sup> have a wiring capacitance of approx. 3 ... 7 nF.



#### Accessories SD interface

For ease of wiring and series-wiring of SD devices, considerable accessories are available. Detailed information is available on the Internet, [www.schmersal.net](http://www.schmersal.net).

### 5. Operating principles, coding and latching force adjustment

#### 5.1 Magnet control

In the power to unlock version of the AZM300, the solenoid interlock is unlocked when the IN signal (= 24V) is set. In the power to lock version of the AZM300, the solenoid interlock is locked when the IN signal (= 24 V) is set.

#### 5.2 Mode of operation of the safety outputs

In the standard AZM 300Z variant, the unlocking of the solenoid interlock causes the safety outputs to be disabled. The unlocked safety guard can be relocked as long as the actuator is inserted in the AZM 300Z solenoid interlock; in that case, the safety outputs are re-enabled. **The safety guard must not be opened.**

In the AZM300B version, only the opening of the safety guard causes the safety outputs to be disabled.

If the safety outputs are already enabled, any error that does not immediately affect the functionality of the solenoid interlock (e.g. too high an ambient temperature, interference potential at the safety outputs, cross-wire short) will lead to a warning message, the disabling of the diagnostic output and the delayed shutdown of the safety outputs. The safety outputs are disabled if the error warning is active for 30 minutes. The signal combination, diagnostic output disabled and safety channels still enabled, can be used to stop the production process in a controlled manner. After the rectification of the error, the error message is reset by opening the corresponding safety guard. For devices with serial diagnostic, a bit can be set/ deleted in the call telegram to reset the fault.

#### 5.3 Actuator teaching / actuator detection

Solenoid interlocks with standard coding are ready to use upon delivery.

Individually coded solenoid interlocks and actuators will require the following "teach-in" procedure:

1. Switch the solenoid interlock's voltage supply off and back on.
2. Introduce the actuator in the detection range. The teach-in procedure is signalled at the solenoid interlock, green LED off, red LED on, yellow LED flashes (1 Hz).
3. After 10 seconds, brief yellow cyclic flashes (3 Hz) request the switch-off of the operating voltage of the solenoid interlock. (If the voltage is not switched off within 5 minutes, the solenoid interlock cancels the "teach-in" procedure and signals a false actuator by 5 red flashes).
4. After the operating voltage is switched back on, the actuator must be detected once more in order to activate the taught actuator code. In this way, the activated code is definitively saved!

For ordering suffix -I1, the thus executed allocation of safety switchgear and actuator is irreversible.

For ordering suffix -I2, the "teach-in" procedure for a new actuator can be repeated an unlimited number of times. When a new actuator is taught, the code, which was applicable until that moment, becomes invalid. Subsequent to that, an enabling inhibit will be active for ten minutes, thus providing for an increased protection against tampering. The green LED will flash until the expiration of the time of the enabling inhibit and the detection of the new actuator. In case of power failure during the lapse of time, the 10-minutes tampering protection time will restart.

#### 5.4 Latching force adjustment

In order to enable trouble-free functionality of the device, the rotary handle must be in position I or II when the safety guard is open. In the intermediate positions, locking is impossible.

The latching force is changed by turning the rotary handle by 180°.

In position I, the latching force is approx. 25 N.

In position II, the latching force is approx. 50 N.

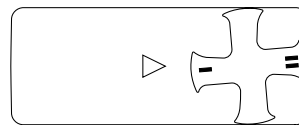

### 6. Diagnostic function

#### 6.1 Diagnostic-LEDs

The solenoid interlock signals the operating condition, as well as errors through 3-colour LED's.

<b>green</b> (Power)	supply voltage on
<b>yellow</b> (Status)	operating condition
<b>red</b> (Fault)	Fault (see Table 2: Flash codes of the red diagnostic LED)

#### 6.2 Solenoid interlock with conventional diagnostic output

The short-circuit proof diagnostic output OUT can be used for central visualisation or control functions, e.g. in a PLC.

**The diagnostic output is not a safety-related output!**

#### Error

Errors, which no longer guarantee the function of the solenoid interlock (internal errors) cause the safety outputs to be disabled immediately. Any error that does not immediately affect the safe functionality of the AZM300 solenoid interlock (e.g. excess ambient temperature, safety output to external potential, short circuit) will lead to a delayed shut-down (refer to table 2). After the rectification of the error, the error message is reset by opening the corresponding safety guard.

#### Error warning

A fault has occurred, which causes the safety outputs to be disabled after 30 minutes (LED "fault" flashes, see Table 2). The safety outputs initially remain enabled. This enables the shutdown of the process in a controlled manner. An error warning is deleted when the cause of error is eliminated.

**Behaviour of diagnosis output based on interlock with power to unlock as an example**

#### Input signal magnet control

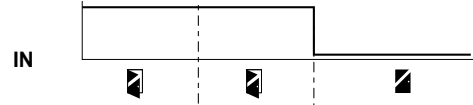

#### Normal sequence, door was locked

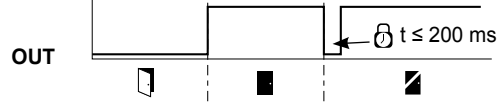

#### Door could not be locked or fault

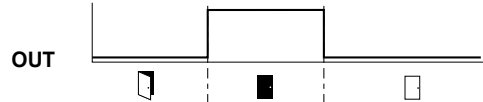

#### Key

- Safety guard open
- Safety guard closed
- Unlock safety guard
- Safety guard locked
- Locking time
- Safety guard not locked or fault

#### Evaluation of the diagnostic outputs

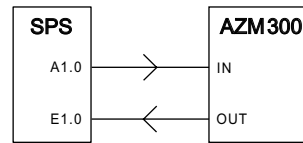

Power to unlock: IN = 0 = locking

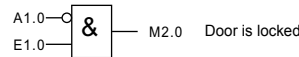
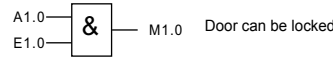

Power to lock: IN = 1 = locking

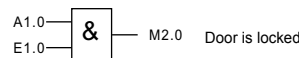
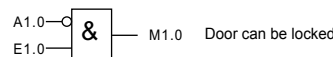

**Table 1: Diagnostic information of the safety switchgear**

The safety switch signals the operational state as well as errors through three coloured LED's installed on the device.

System condition	Solenoid control IN		LED			Safety outputs Y1, Y2		Diagnostic output OUT
	Power to unlock	Power to lock	green	red	yellow	AZM300Z	AZM300B	
Safety guard open	24 V (0 V)	0 V (24 V)	On	Off	Off	0 V	0 V	0 V
Door closed, <b>not locked</b>	24 V	0 V	On	Off	Flashes	0 V	24 V	24 V
Door closed, <b>locking impossible</b>	0 V	24 V	On	Off	Flashes	0 V	24 V	0 V
Door closed and locked	0 V	24 V	On	Off	On	24 V	24 V	24 V
Error warning <sup>1)</sup>	0 V	24 V	On	Flashes <sup>2)</sup>	Off	24 V <sup>1)</sup>	24 V <sup>1)</sup>	0 V
Error	0 V (24 V)	24 V (0 V)	On	Flashes <sup>2)</sup>	Off	0 V	0 V	0 V
<b>Additionally for variant I1/I2:</b>								
Teach-in procedure actuator started			Off	On	Flashes	0 V	0 V	0 V
Only I2: teach-in procedure actuator (release block)			Flashes	Off	Off	0 V	0 V	0 V

1) after 30 min: disabling due to fault

2) refer to flash code



Table 2: Error messages / flash codes red diagnostic LED

Flash codes (red)	Designation	Autonomous switch-off after	Error cause
1 flash pulse	Error (warning) at output Y1	30 min	Fault in output test or voltage at output Y1, although the output is disabled.
2 flash pulses	Error (warning) at output Y2	30 min	Fault in output test or voltage at output Y2, although the output is disabled.
3 flash pulses	Error (warning) cross-wire short	30 min	Cross-wire short between the output cables or fault at both outputs
4 flash pulses	Error (warning) temperature too high	30 min	The temperature measurement reveals an internal temperature that is too high
5 flash pulses	Actuator fault	0 min	Incorrect or defective actuator, bracket broken
6 flash pulses	Fault rotary handle	0 min	Rotary handle not in authorised intermediate position
Continuous red signal	Internal error	0 min	Device defective

**6.3 Solenoid interlock with serial diagnostic function SD**

Solenoid interlocks with serial diagnostic cable have a serial input and output cable instead of the conventional diagnostic output. If solenoid interlocks are wired in series, the diagnostic data are transmitted through the series-wiring of the inputs and outputs.

Max. 31 solenoid interlocks can be wired in series. For the evaluation of the serial diagnostics line either the PROFIBUS-Gateway SD-I-DP-V0-2 or the Universal-Gateway SD-I-U-... are used. This serial diagnostic interface is integrated as a slave in an existing field bus system. In this way, the diagnostic signals can be evaluated by means of a PLC.

The response data and the diagnostic data are automatically and permanently written in an input byte of the PLC for each solenoid interlock in the series-wired chain. The request data for each solenoid interlock is transmitted to the component through an output byte of the PLC. In case of a communication error between the field bus gateway and the solenoid interlock, the switching condition of the solenoid interlock is maintained.

**Error**

A fault has occurred, which causes the safety outputs to be disabled. The fault is reset, when the cause is eliminated and bit 7 of the request byte changes from 1 to 0 or the safety guard is opened. Faults at the safety outputs are only deleted upon the next release, as the fault rectification cannot be detected sooner.



If more than one fault is detected at the safety outputs, the AZM 300 will be electronically locked and a normal fault reset will no longer be possible. To reset this type of interlocking, the AZM 300, must be isolated from the power supply after elimination of the error causes.

**Error warning**

A fault has occurred, which causes the safety outputs to be disabled after 30 minutes. The safety outputs initially remain enabled. This enables the shutdown of the process in a controlled manner. An error warning is deleted when the cause of error is eliminated.

**Diagnostic error (warning)**

If an error (warning) is signalled in the response byte, detailed fault information can be read out.

Table 3: I/O data and diagnostic data

(The described condition is reached, when Bit = 1)

Bit n°	Request byte	Response byte	Diagnostic error warning	Diagnostic error
Bit 0:	Magnet on, irrespective of power to lock or power to unlock principle	Safety output activated	Error output Y1	Error output Y1
Bit 1:	---	Safety guard closed AND locking/unlocking possible	Error output Y2	Error output Y2
Bit 2:	---	Actuator detected and locked	Cross-wire short	Cross-wire short
Bit 3:	---	---	Temperature too high	Temperature too high
Bit 4:	---	Input condition X1 and X2	---	Incorrect or defective actuator, bracket broken
Bit 5:	---	Valid actuator detected	Internal device error	Internal device error
Bit 6:	---	Error warning <sup>1)</sup>	Communication error between the field bus Gateway and the safety switchgear	---
Bit 7:	Error reset	Error (enabling path switched off)	Rotary handle not in authorised intermediate position	Rotary handle not in authorised intermediate position

1) after 30 min -> fault

The leading diagnosis message through bit 1 indicates whether locking or unlocking of the guard system is possible.

The solenoid interlock **cannot be unlocked** if e.g. the door pulls the turret out of its rest position beyond the set latching force.

This can occur if doors are heavily distorted or when pulling the door.

The solenoid interlock can only be **locked** if the turret is in the rest position, i.e. the latching force is sufficient to pull the guard system into the correct position.

### 7. Set-up and maintenance

#### 7.1 Functional testing

The safety function of the safety components must be tested. The following conditions must be previously checked and met:

1. Check max. axial misalignment of actuator and solenoid interlock.
2. Check max. angular misalignment (see "Mounting" part)
3. Fitting and integrity of the cable connections.
4. Check the switch enclosure for damage.
5. Remove particles of dust and soiling.
6. For variants with an emergency exit and emergency release, the following is to be considered:
  - For variants with emergency exits it should be possible to open the safety guard inside the hazardous area; it should not be possible to lock the safety guard from inside.
  - By operating the emergency release lever outside of the hazardous zone it must be possible to open the guard system.

#### 7.2 Maintenance

In the case of correct installation and adequate use, the safety switchgear features maintenance-free functionality. A regular visual inspection and functional test, including the following steps, is recommended:

- Check for a secure installation of the actuator and the solenoid interlock
- Check max. axial misalignment of actuator and solenoid interlock.
- Check max. angular misalignment (see "Mounting" part)
- Fitting and integrity of the cable connections.
- Check the switch enclosure for damages
- Remove soiling



Adequate measures must be taken to ensure protection against tampering either to prevent tampering of the safety guard, for instance by means of replacement actuators.

**Damaged or defective components must be replaced.**

### 8. Disassembly and disposal

#### 8.1 Disassembly

The safety switchgear must be disassembled in a de-energised condition only.

#### 8.2 Disposal

The safety switchgear must be disposed of in an appropriate manner in accordance with the national prescriptions and legislations.

### 9. Appendix

#### 9.1 Wiring examples

The application examples shown are suggestions. They however do not release the user from carefully checking whether the switchgear and its set-up are suitable for the individual application.

#### Wiring example 1: Series-wiring of the AZM300 with conventional diagnostic output

The voltage is supplied at both safety inputs of the terminal safety component of the chain (considered from the safety-monitoring module). The safety outputs of the first safety component are wired to the safety-monitoring module.

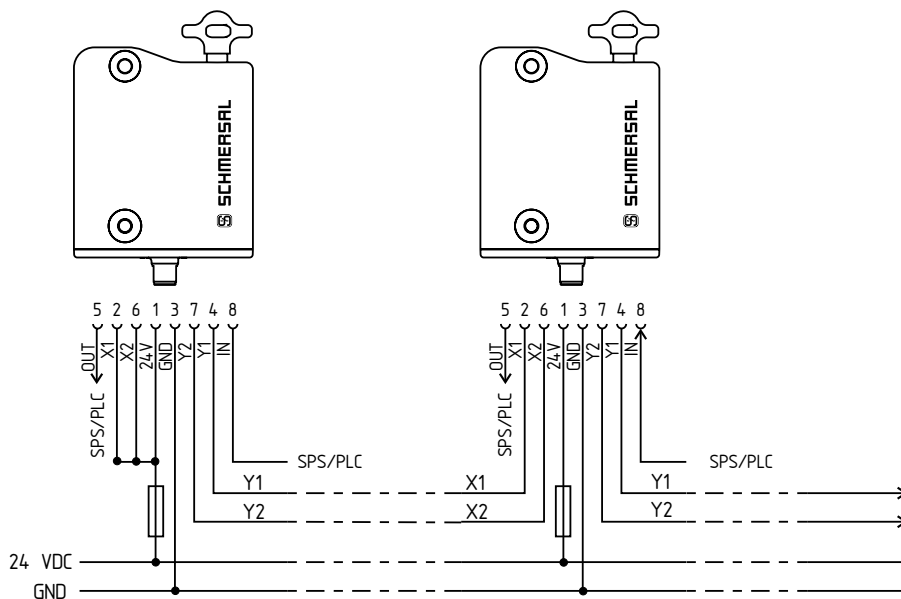

Y1 and Y2 = Safety outputs → Safety monitoring module

**Wiring example 2: Series-wiring of the AZM300 with serial diagnostic function**

The safety outputs of the first safety component are wired to the safety-monitoring module. The serial Diagnostic Gateway is connected to the serial diagnostic input of the first safety component.

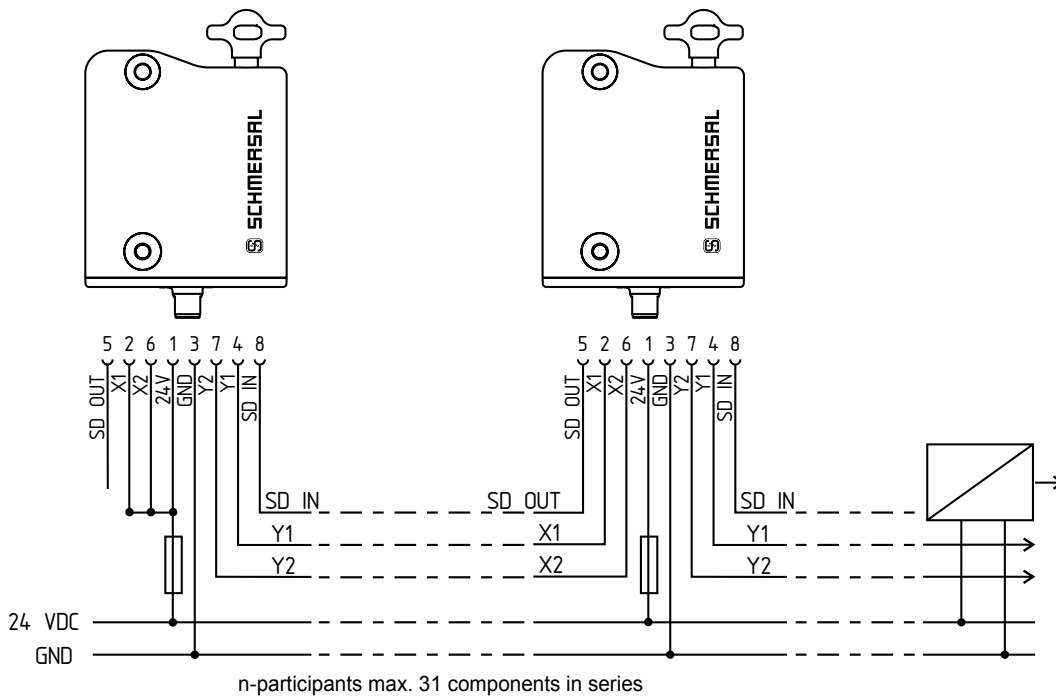

Y1 and Y2 = Safety outputs → Safety monitoring module  
SD-IN → Gateway → Field bus

**9.2 Wiring configuration and connector accessories**

Function safety switchgear		Pin configuration of the connector 	Colour codes of the Schmersal connectors		Poss. colour codes of other customary connectors to IEC 60947-5-2: 2007
With conventional diagnostic output	with serial diagnostic function		IP67 / IP69 to DIN 47100	IP69K (PVC)	
<b>A1</b>	U <sub>e</sub>		1	WH	BN
<b>X1</b>	Safety input 1		2	BN	WH
<b>A2</b>	GND		3	GN	BU
<b>Y1</b>	Safety output 1		4	YE	BK
<b>OUT</b>	Diagnostic output	SD output	5	GY	GY
<b>X2</b>	Safety input 2		6	PK	VT
<b>Y2</b>	Safety output 2		7	BU	RD
<b>IN</b>	Solenoid control	SD input	8	RD	PK

**Connecting cables with coupling (female)**  
IP67 / IP69, M12, 8-pole - 8 x 0.23 mm<sup>2</sup>  
to DIN 47100

Cable length	Part number
2.5 m	103011415
5.0 m	103007358
10.0 m	103007359

**Connecting cables with coupling (female)**  
IP69K, M12, 8-pole - 8 x 0.21 mm<sup>2</sup>

Cable length	Part number
5.0 m	101210560
5.0 m, angled	101210561

10. EU Declaration of conformity

<b>EU Declaration of conformity</b>		 <b>SCHMERSAL</b>
Original	K.A. Schmersal GmbH & Co. KG Möddinghofe 30 42279 Wuppertal Germany Internet: www.schmersal.com	
We hereby certify that the hereafter described components both in their basic design and construction conform to the applicable European Directives.		
<b>Name of the component:</b>	AZM300	
<b>Type:</b>	Refer to ordering code	
<b>Description of the component:</b>	Interlocking device with electromagnetic interlock for safety functions	
<b>Relevant Directives:</b>	Machinery Directive	2006/42/EC
	RED-Directive	2014/53/EU
	RoHS-Directive	2011/65/EU
<b>Applied standards:</b>	IEC 60947-5-3:2013, EN ISO 14119:2013, EN 300 330 V2.1.1:2017, EN ISO 13849-1:2008 + AC:2009, IEC 61508 parts 1-7:2010, EN 62061:2005 + AC:2010 + A1:2013	
<b>Notified body for the prototype test:</b>	TÜV Rheinland Industrie Service GmbH Alboinstr. 56, 12103 Berlin ID n°: 0035	
<b>EC-prototype test certificate:</b>	01/205/5281.02/15	
<b>Person authorised for the compilation of the technical documentation:</b>	Oliver Wacker Möddinghofe 30 42279 Wuppertal	
<b>Place and date of issue:</b>	Wuppertal, August 17, 2017	
		
	Authorised signature <b>Philip Schmersal</b> Managing Director	

AZM300-F-EN



The currently valid declaration of conformity can be downloaded from the internet at [www.schmersal.net](http://www.schmersal.net).



**K. A. Schmersal GmbH & Co. KG**  
Möddinghofe 30, D - 42279 Wuppertal  
Postfach 24 02 63, D - 42232 Wuppertal

Phone: +49 - (0)2 02 - 64 74 - 0  
Telefax: +49 - (0)2 02 - 64 74 - 1 00  
E-Mail: [info@schmersal.com](mailto:info@schmersal.com)  
Internet: <http://www.schmersal.com>

## X-ON Electronics

Largest Supplier of Electrical and Electronic Components

*Click to view similar products for [Emergency Stop Switches / E-Stop Switches](#) category:*

*Click to view products by [Schmersal](#) manufacturer:*

Other Similar products are found below :

[84-5021.2B40](#) [84-6830.0020](#) [A01ESSP8](#) [A22EL-M-24A-11B](#) [AVN302N-R](#) [A165E-S-01\(STOP\)](#) [AYLD2212602SN-R-TK962](#)  
[AVLD39911N-R-24V](#) [A22Z-EG22](#) [A165E-SY](#) [3100.0110Y](#) [3050.1302Y](#) [3SE2243-0XX40](#) [3SK1111-2AB30](#) [3SK1211-1BB40](#) [44-710](#) [84-](#)  
[6841.2B20](#) [84-6830.0040](#) [H3141AAKAA](#) [A165E-R-24D-01](#) [E3102AAAAB](#) [A22E-M-03](#) [ZA2BV05](#) [A22EL-M-T2-01](#) [951FY000-WO](#)  
[ER6022-022N](#) [952+2000-00](#) [ES3S51653](#) [601+0000-OP](#) [E3101AAAAB](#) [84-5130.0040](#) [CS AR-05V024](#) [CS AR-22V024](#) [DS AE1VA](#) [DS](#)  
[KB2A](#) [DS KB3A](#) [HE2G-21SHE-L-K](#) [HE6B-M211Y](#) [774191](#) [774316](#) [777760](#) [R1.100.0129.0 SMA0129- NO/NO](#) [R1.188.0640.0 SNV](#)  
[4063KL-A](#) [R1.188.1810.0 SNA 4043K-A](#) [R1.188.1840.0 SNA 4043K-A](#) [SR BD40ALK-B02F](#) [AVLW39911D-R-120V](#) [AYD311NUG](#)  
[AVLD32211DNUR](#) [84-5040.0020.0049](#)