

Description

Magnecraft™ Power Relays

92

DPST-NO, 30 A;

DPDT, 30 A (NO) / 3 A (NC)



92S11A22D

Description

The 92 series power relays offer a small package size and features Class F insulation for a maximum coil temperature of 155 °C (311 °F). These power relays meet UL508 spacing and are directly DIN or panel mountable.

Feature	Benefit
Standard Class F insulation	Allows for maximum coil temperature of 155 °C (311 °F) which is ideal for elevated temperature applications
DIN and panel mount cover	Mounts directly onto DIN rail or panel and provides flexibility to accommodate last minute design changes
Sealed construction	Suitable for washing to remove flux residues

Rated Contact Current	Contact Configuration	Coil Voltage	Coil Resistance (Ω)	Standard Part Number
30 A	DPST-NO	24 Vac	170 ¹	92S7A22D-24
		120 Vac	4250 ¹	92S7A22D-120
		240 Vac	15600 ¹	92S7A22D-240
		12 Vdc	86	92S7D22D-12
		24 Vdc	350	92S7D22D-24
30 A (NO) / 3 A (NC)	DPDT	24 Vac	170 ¹	92S11A22D-24
		120 Vac	4250 ¹	92S11A22D-120
		240 Vac	16500 ¹	92S11A22D-240
		12 Vdc	86	92S11D22D-12
		24 Vdc	350	92S11D22D-24

¹ All AC coils are rectified.

Part Number Explanation

Series: **92** **S** **7** **A** **22D** - **24**

Series:
92

Cover:
S = Dust cover

Contact Configuration:
7 = DPST-NO
11 = DPDT

Coil Type:
A = AC
D = DC

Mounting Style:
22D = DIN rail and panel mount cover

Coil Voltage:

12 = 12 V 120 = 120 V
24 = 24 V 240 = 240 V

Note: Available coil voltages include 12 Vdc, 24 Vac, 24 Vdc, 120 Vac, and 240 Vac.

Specifications

Part Number	92S7	92S11
Contact Characteristics		
Contact Configuration	DPST-NO	DPDT
Contact Material	Silver Alloy	
Thermal (Carrying) Current	30 A	30 A (NO); 3 A (NC)
Maximum Switching Voltage (Conforming to IEC)	250 Vac / 28 Vdc	
Maximum Switching Voltage (Conforming to UL)	300 Vac / 28 Vdc	
Current Ratings at Voltage (Conforming to IEC)	(NO) 30 A at 250 Vac; 30 A at 28 Vdc	(NO) 30 A at 250 Vac; 30 A at 28 Vdc (NC) 3 A at 250 Vac; 3 A at 28 Vdc
Current Ratings at Voltage (Conforming to UL)	(NO) General Use: 30 A at 277 Vac Resistive: 20 A at 28 Vdc Motor: 1.0 hp at 120 Vac; 3.0 hp at 240 Vac LRA/FLA : 96 A / 22 A @ 240 Vac (AC coil), 30,000 cycles 110 A / 25.3 A @ 240 Vac (DC coil), 30,000 cycles Pilot Duty: 720 VA / A 300, 6000 cycles Short Circuit: 5000 A rms @ 240 Vac Tungsten: 10 A at 120 Vac 50/60 Hz, 25,000 cycles 6 A at 250 Vac 50/60 Hz, 25000 cycles	(NO) General Use: 30 A at 277 Vac Resistive: 20 A at 28 Vdc Motor: 1.0 hp at 120 Vac; 3.0 hp at 240 Vac LRA/FLA : 96 A / 22 A @ 240 Vac (AC coil), 30,000 cycles 110 A / 25.3 A @ 240 Vac (DC coil), 30,000 cycles Pilot Duty: 720 VA / A 300, 6000 cycles Short Circuit: 5000 A rms @ 240 Vac Tungsten: 10 A at 120 Vac 50/60 Hz, 25,000 cycles 6 A at 250 Vac 50/60 Hz, 25000 cycles (NC) Resistive: 3 A at 277 Vac (6000 cycles); 3 A at 28 Vdc
Switching capacity	Maximum: 7500 VA / 840 W (when mounted with 13 mm gap between 2 relays); 6250 VA / 700 W (when mounted side by side without a gap) Minimum: 170 mW	
Minimum Switching Requirements.	10 mA at 17 V	
Coil Characteristics		
Coil Voltage Range ¹	24–240 Vac ² 50/60 Hz; 12–110 Vdc	
Operating Range (% of Nominal)	80%–120% (AC); 75%–120% (DC)	
Average Consumption	4 VA (AC); 1.7 W (DC)	
Drop-out Voltage Threshold	15% minimum (AC); 10% minimum (DC)	
General Characteristics		
Electrical Life at Rated Load	Resistive load: 100,000 cycles, unless otherwise specified under rated operational current Inductive load: See load curves on page 25.	
Mechanical Life at No Load (Unpowered)	50,000,000 operations	
Operate Time (Response Time) at Nominal Coil Voltage	25 ms maximum	
Rated Impulse Withstand	4000 V (1.2 μs / 50 μs)	
Dielectric Strength	Between coil and contact: 4000 Vac (reinforced insulation) Between poles: 2000 Vac (basic insulation) Between contacts: 1500 Vac (micro-disconnection)	
Operating Temperature Range	-40 – +55 °C (-40 – +131 °F)	
Storage Temperature Range	-40 – +85 °C (-40 – +185 °F)	
Vibration Resistance	3 g-n, 10–55 Hz	
Shock Resistance	10 g-n (in operation) / 30 g-n (not in operation)	
Weight (Average)	0.082 kg (0.181 oz)	
Conformity to Standards	IEC/EN 61810-1, UL 508, CSA C22-2 n°14	
Product Certifications and Standards	UL Listed (E48539), CSA (2582574), CE, RoHS	

Note: Actual product performance may vary depending on application and environmental conditions.

¹ For available standard coil voltages, please refer to the standard part number table on page 23.

² All AC coils are rectified.

Specifications (continued)

Electrical durability of contacts		
Resistive load	AC reduction coefficient for inductive load (depending on power factor $\cos \varphi$) Durability (inductive load) = durability (resistive load) x reduction coefficient.	Maximum switching capacity on DC resistive load

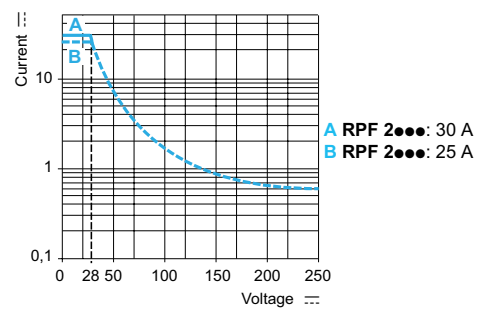
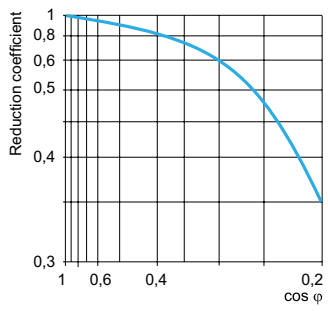
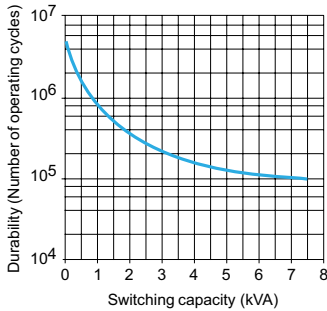

Note: These curves are for reference only and are typical values only. Actual performance is dependant upon the actual load, environment, duty cycle, and other conditions specific to the application.

Dimensions — inches (millimeters)

DPST-NO (2 NO):

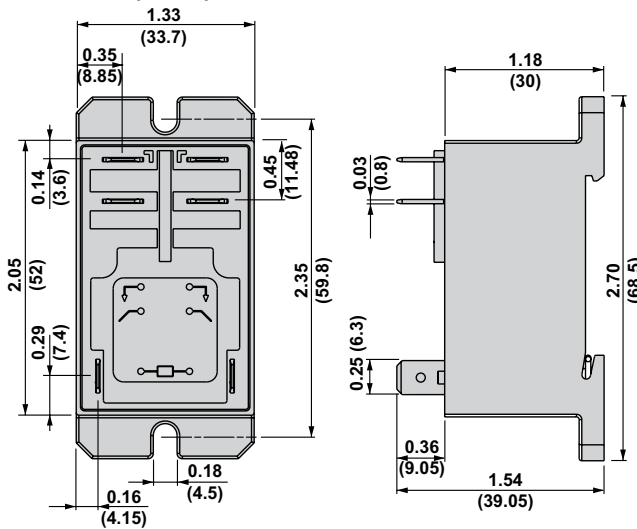

DPDT (2 CO):

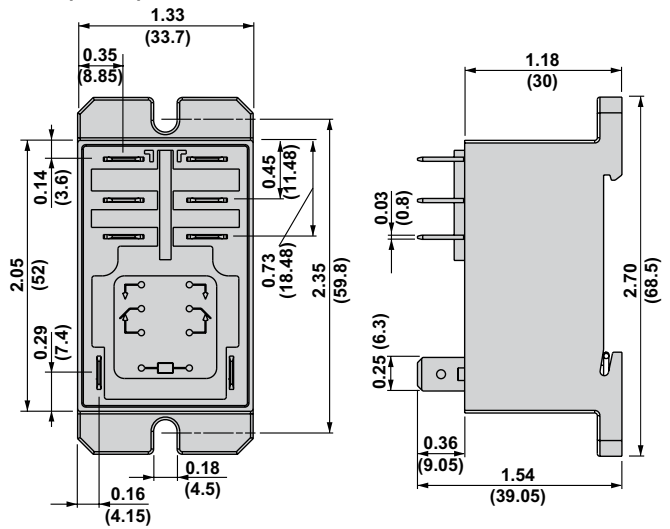

Wiring Diagrams

DPST-NO (2 NO):

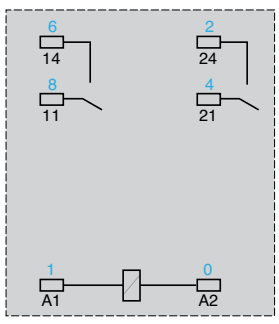

DPDT (2 CO):

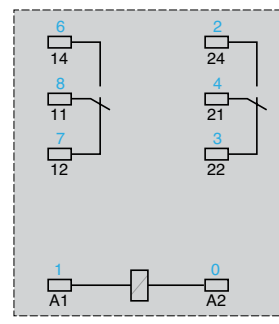

X-ON Electronics

Largest Supplier of Electrical and Electronic Components

Click to view similar products for [General Purpose Relays](#) category:

Click to view products by [Schneider](#) manufacturer:

Other Similar products are found below :

[PCN-105D3MH,000](#) [59641F200](#) [LY1SAC110120](#) [5X827E](#) [5X837F](#) [5X840F](#) [5X842F](#) [5X848E](#) [LY2N-AC120](#) [LY2S-AC220/240](#) [LY2-US-AC120](#) [LY3-US-AC120](#) [LY4F-UA-DC12](#) [LY4F-UA-DC24](#) [LY4F-US-AC120](#) [LY4F-US-AC240](#) [LY4F-US-DC24](#) [LY4F-VD-AC110](#) [LYQ20DC12](#) [M115C60](#) [M115N010](#) [M115N0150](#) [6031007G](#) [603-12D](#) [61211T0B4](#) [61212T400](#) [61222Q400](#) [61243B600](#) [61243C500](#) [61243Q400](#) [61311BOA2](#) [61311BOA6](#) [61311BOA8](#) [61311C0A2](#) [61311COA1](#) [61311COA6](#) [61311F0A2](#) [61311QOA1](#) [61311QOA4](#) [61311T0D6](#) [61311TOA6](#) [61311TOA7](#) [61311TOB3](#) [61311TOB4](#) [61311U0A6](#) [61312Q600](#) [61312T400](#) [61312T600](#) [61313U200](#) [61313U400](#)