

Panelboards – Ready To Install (RTI)

Selection Guide

Contents	Description	Page
NQ - 240 Volt Lighting and Distribution Panelboard		
	• QO - Plug On Branch Breakers	2 - 3
	• QOB - Bolt On Branch Breakers	4
	• QO/QOB Branch Breaker Accessories	5
	• Panelboards - 20" Wide Enclosures - Main Lugs Only	6
	• Panelboards - 20" Wide Enclosures - Main Breakers	7
	• Panelboards - 20" Wide Enclosures - Optional LugKits and Accessories	8
	• Panelboards - Box Sizing Requirements	9
	• Panelboards - 14" Wide NQ Enclosures - Main Lugs and Main Breakers	10
NF - 600Y/347 Volt Lighting and Distribution Panelboard		
	• E-Frame Branch Breakers	11
	• Panelboards - 20" Wide Enclosures - Main Lugs Only	12
	• Panelboards - 20" Wide Enclosures - Main Breakers	13
	• Accessories	14-15
NQ/NF Single Row Panelboards		
	• Application Data	16
I-Line - 600 Volt Breaker Power Panelboard		
	• Ready to Install - Main Lugs - Main Breakers	17-19
	• Accessories, Panel Equipment Data	20-22
	• Branch Breakers	23-29
	• Factory Assembled I-Line Panelboards	30
	• Factory Assembled I-Line Combo Panelboards	31
QMB/QMJ - Fusible Power Panelboard		
	• Branch Switches, HP Ratings, Lug Data	32-34
Special Features for Factory Assembled Panels		
	• Metering, Customer Equipment Space	35
	• Key Interlock, Motor Operators for I-Line Breakers	35
	• Enclosure Modifications	36
	• Enclosure Options	37-38
	• Panels to fit existing enclosures	39-40
	• Special Enclosures	41
Other Panelboards		
	• Obsolete Panelboards Information	41

QO® Circuit Breakers

with VISI-TRIP® Indicator

QO 1-pole



1 Space Required

QO 2-pole



2 Spaces Required

QO Three-pole



3 Spaces Required

QO2200 2-pole
200 A



4 Spaces Required

QO/QOB Ring Terminal (20% Price Adder)—Factory-installed Only

Ampere Rating	Poles	Suffix
10-30	1, 2, 3	5237
35-60	1, 2	
35-50	3	5238
70-110	2	
60-100	3	5273

Circuit Breaker Wire Sizes▲

Breaker Type	Ampere Rating	Wire Size (AWG)	
		Al	Cu
QO 1-pole	10-30	#14-8	#14-8
	10-30	...	(2) #14-10
	35-70	#8-2	#8-2
QO 2-pole	10-30	#14-8	#14-8
	10-30	...	(2) #14-10
	35-70	#8-2	#8-2
	80-125	#4-2/0	#4-2/0
QO 3-pole	10-30	#14-8	#14-8
	35-70	#8-2	#8-2
	80-125	#4-2/0	#4-2/0
QOB-VH	110-150	#4-300 kcmil	#4-300 kcmil
	110-150	#4-300 kcmil	#4-300 kcmil
QO-AFI, QO-GFI & QO-EPD	15-30	#12-8	#14-8
	40, 50, 60	#12-4	#14-6
QO-PL	10-60	#12-2	#14-2

QO Miniature Circuit Breakers

SQUARE D QO miniature circuit breakers are plug-on products for use in QO load centers, NQ panelboards, NQ OEM interiors or SPEED-D® switchboard distribution panels. Bolt-on QOB circuit breakers are for use in NQ panelboards or interiors.*

Plug-On Circuit Breakers—CSA Listed Amperes Interrupting Rating (AIR) In Amperes RMS Symmetrical

Amperes Rating▲	1-pole—120/240 Vac	2-pole—120/240 Vac Common Trip	2-pole—240 Vac ■ Common Trip	Three-pole—240 Vac Common Trip
	Catalogue Number	Catalogue Number	Catalogue Number	Catalogue Number
10,000 AIR				
10	QO110	QO210	...	QO310
15	QO115 ◆★	QO215 ◆	QO215H	QO315 ◆
20	QO120 ◆★	QO220 ◆	QO220H	QO320 ◆
25	QO125 ◆	QO225 ◆	QO225H	QO325 ◆
30	QO130 ◆	QO230 ◆	QO230H	QO330 ◆
35	QO135 ◆	QO235 ◆	...	QO335 ◆
40	QO140 ◆	QO240 ◆	QO240H	QO340 ◆
45	QO145 ◆	QO245 ◆	...	QO345 ◆
50	QO150 ◆	QO250 ◆	QO250H	QO350 ◆
60	QO160 ◆	QO260 ◆	QO260H	QO360 ◆
70	QO170 ◆	QO270 ◆	QO270H	QO370 ◆
80	...	QO280 ◆	QO280H	QO380 ◆
90	...	QO290 ◆	QO290H	QO390 ◆
100	...	QO2100 ◆	QO2100H	QO3100 ◆
110	...	QO2110 ◆
125	...	QO2125 ◆
150
175
200
Molded Case Switch 60 A max.—240 Vac		...	QO200	QO300
Molded Case Switch 100 A max.—240 Vac		...	QO2000△	QO3000△
22,000 AIR				
15	QO115VH ◆★	QO215VH ◆	...	QO315VH ◆
20	QO120VH ◆★	QO220VH ◆	...	QO320VH ◆
25	QO125VH ◆	QO225VH ◆	...	QO325VH ◆
30	QO130VH ◆	QO230VH ◆	...	QO330VH ◆
40	...	QO240VH ◆	...	QO340VH ◆
50	...	QO250VH ◆	...	QO350VH ◆
60	...	QO260VH ◆	...	QO360VH ◆
70	...	QO270VH ◆	...	QO370VH ◆
80	...	QO280VH ◆	...	QO380VH ◆
90	...	QO290VH ◆	...	QO390VH ◆
100	...	QO2100VH ◆	...	QO3100VH ◆
110	...	QO2110VH ◆
125	...	QO2125VH ◆
150
175
200
42,000 AIR				
40	...	QOH240 ◆△
45	...	QOH245 ◆△
50	...	QOH250 ◆△
60	...	QOH260 ◆△
70	...	QOH270 ◆
80	...	QOH280 ◆
90	...	QOH290 ◆
100	...	QOH2100 ◆
110	...	QOH2110 ◆△
125	...	QOH2125 ◆
65,000 AIR				
15	QH115 ◆★	QH215 ◆	...	QH315 ◆
20	QH120 ◆★	QH220 ◆	...	QH320 ◆
25	QH125 ◆△	QH225 ◆△	...	QH325 ◆△
30	QH130 ◆	QH230 ◆	...	QH330 ◆

- ▲ 10-30 A circuit breakers are suitable for use with 60°C or 75°C conductors. 35-125 A circuit breakers are suitable for use with 75°C conductors.
- CSA Listed 5000 AIR on corner grounded Delta systems.
- ◆ CSA Listed as HACR type for use with air conditioning, heating and refrigeration equipment having motor group combinations and marked for use with HACR type circuit breakers.
- ★ CSA Listed as SWD (switching duty) rated. Suitable for switching 120 Vac fluorescent lighting loads.
- ▼ Requires four spaces (#1-300 kcmil Al/Cu). Not suitable for use in 3-phase panel. Use only in single phase panel rated 150 A or greater.
- △ Order only. Contact your nearest Schneider Electric sales office.
- CSA Listed for use ahead of QO, QO-GFI, QO-EPD, QOT, and QO-PL 10,000 AIR circuit breakers to permit their application at 22,000 A fault level.
- ◇ 100 A maximum branch mounted opposite.
- ★ See Digest Section DE1 for load centers, and this Section for panelboards and interiors.

DE5 PANELBOARDS

Additional Information
Accessories DE5-5

QO® Circuit Breakers

with VISI-TRIP® Indicator

Plug-On Circuit Breakers

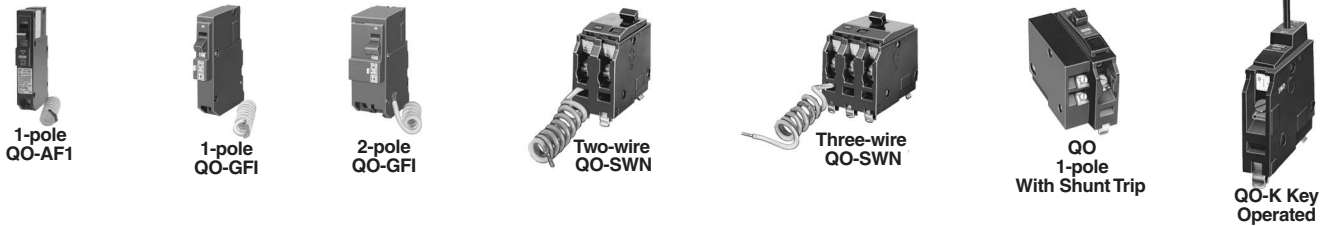

QO-HM High magnetic trip circuit breakers are recommended for applications where high initial inrush may occur and for individual dimmer applications.

Ampere Rating ▲	1-pole	
	Catalogue No.	
120 Vac—10,000 AIR		
15	QO115HM◆★	
20	QO120HM◆★	

QO-AFI QO Circuit Breakers with arc fault protection in accordance with UL1699.

Ampere Rating ▲	1-pole 120 Vac	
	10,000 AIR	22,000 AIR
	1 Space Required	1 Space Required
Catalogue No.		
15	QO115AFI★	QO115VHAFI★
20	QO120AFI★	QO120VHAFI★

QO-GFI QWIK-GARD® circuit breakers with Class A 4-6 mA ground fault protection. ▼

Ampere Rating ▲	QWIK-GARD Circuit Breakers With Ground Fault Circuit Interrupter		
	1-pole 120 Vac		2-pole Common Trip 120/240 Vac
	10,000 AIR	22,000 AIR	10,000 AIR
	1 Space Required	1 Space Required	2 Spaces Required
Catalogue No.			
15	QO115GFI	QO115VHGF1	QO215GFI
20	QO120GFI	QO120VHGF1	QO220GFI
25	QO125GFI	QO125VHGF1	QO225GFI
30	QO130GFI	QO130VHGF1	QO230GFI
40	QO240GFI
50	QO250GFI
60	QO260GFI■

QO-EPD QO-EPD circuit breakers provide overload and short circuit protection combined with Class B 30 mA ground fault protection.

Ampere Rating ▲	1-pole 120 Vac		2-pole Common Trip 120/240 Vac	
	10,000 AIR		10,000 AIR	
	1 Space Required		2 Spaces Required	
Catalogue No.				
15	QO115EPD	QO215EPD	QO215EPD	QO215EPD
20	QO120EPD	QO220EPD	QO220EPD	QO220EPD
25	QO125EPD	QO225EPD	QO225EPD	QO225EPD
30	QO130EPD	QO230EPD	QO230EPD	QO230EPD
40	QO240EPD	QO240EPD	QO240EPD
50	QO250EPD	QO250EPD	QO250EPD
60	QO260EPD	QO260EPD	QO260EPD

QO-SWN Switch Neutral Common Trip 2002 NEC® 514.11

Ampere Rating ▲	2 Wire 120 Vac		3 Wire 120/240 Vac	
	10,000 AIR		10,000 AIR	
	2 Spaces Required		3 Spaces Required	
Catalogue No.				
10	QO210SWN	QO310SWN	QO310SWN	QO310SWN
15	QO215SWN	QO315SWN	QO315SWN	QO315SWN
20	QO220SWN	QO320SWN	QO320SWN	QO320SWN
25	QO225SWN	QO325SWN	QO325SWN	QO325SWN
30	QO230SWN	QO330SWN	QO330SWN	QO330SWN
40	QO240SWN	QO340SWN	QO340SWN	QO340SWN
50	QO250SWN	QO350SWN	QO350SWN	QO350SWN

No overcurrent protection or short circuit protection.

- ▲ 10–30 ampere breakers are suitable for use with 60°C or 75°C conductors. 35–60 ampere circuit breakers are suitable for use with 75°C conductors.
- Suitable only for feeding 240 Vac and 208 Vac 2 wire loads. Does not contain load neutral connection.
- ◆ CSA Listed as SWD (switching duty) rated. Suitable for switching 120 Vac fluorescent lighting loads.
- ★ CSA Listed as HACR type for use with air conditioning, heating and refrigeration equipment having motor group combinations and marked for use with HACR type circuit breakers.
- ▼ Do not connect to more than 250 feet of load conductor for the total one-way run to prevent nuisance tripping.

QO-HID QO-HID Circuit Breakers

HID circuit breakers are for use on circuits feeding fluorescent and high intensity discharge (HID) lighting systems such as mercury vapor, metal halide, or high pressure sodium.

Ampere Rating ▲	1-pole 120/240 Vac	2-pole Common Trip 120/240 Vac	3-pole Common Trip 240 Vac
	10,000 AIR	10,000 AIR	10,000 AIR
1 Space Required			
2 Spaces Required			
3 Spaces Required			
Catalogue No.			
15	QO115HID◆	QO215HID	QO315HID
20	QO120HID◆	QO220HID	QO320HID
25	QO125HID	QO225HID	QO325HID
30	QO130HID	QO230HID	QO330HID
40	QO140HID	QO240HID
50	QO150HID	QO250HID

QO-K Key operated QO circuit breakers can be turned ON or OFF or to RESET with a special key (Catalogue No. QOK10) included with the circuit breaker.

120 Vac—10,000 AIR (1 Space Required)	
Ampere Rating ▲	Catalogue No.
10	QO110K
15	QO115K
20	QO120K
25	QO125K
30	QO130K

Non-automatic Molded Case Switches

Miniature non-automatic switches have the same physical packaging as miniature circuit breakers, but open only when the handle is switched to the OFF position.

240 Vac 10,000 AIR 1 Space Required

Ampere Rating	2-pole	3-pole
	Catalogue No.	Catalogue No.
60	QO200	QO300
100	QO2000	QO3000

QO Combination Arc-Fault Interrupter (CAFI)

QO Combination Arc-Fault Interrupter (CAFI) provides overload and short circuit protection, plus both series and parallel type arc protection as required in 2015 CEC. Integrated with Time Saver diagnostics, QO CAFI breaker improves circuit troubleshooting at the touch of a button.

Ampere Rating	1 Pole 120 Vac		2 Pole 120/240 Vac		Circuit Breaker Type
	10,000 AIR	22,000 AIR	10,000 AIR	22,000 AIR	
	1 Space Required		2 Spaces Required		
Catalogue No.					
15	QO115CAFI	QO115VHCAFI	QO215CAFI	QO215VHCAFI	QO Pigtail Neutral CAFI
20	QO120CAFI	QO120VHCAFI	QO220CAFI	QO220VHCAFI	QO Pigtail Neutral CAFI
15	QO115PCAFI	QO115VHPCAFI	---	---	QO Plug-on Neutral CAFI
20	QO120PCAFI	QO120VHPCAFI	---	---	QO Plug-on Neutral CAFI

QO Dual Function Circuit Breaker

QO Dual Function (DF) breaker provides both combination arc-fault and ground-fault (5mA classA) protection in a single compact device. Integrated with Plug-on Neutral and Time Saver Diagnostics features, QO DF breaker offers maximum circuit protection and installation flexibility.

Ampere Rating	1 Pole 120 Vac		Circuit Breaker Type
	10,000 AIR	22,000 AIR	
	1 Space Required		
Catalogue No.			
15	QO115DF	QO115VHDF	QO Dual Function with Pigtail Neutral
20	QO120DF	QO120VHDF	QO Dual Function with Pigtail Neutral
15	QO115PDF	QO115VHPDF	QO Plug-on Neutral Dual Function
20	QO120PDF	QO120VHPDF	QO Plug-on Neutral Dual Function

QOB Bolt-On Circuit Breakers

With VISI-TRIP® Indicator for NQ Panelboards

Ampere Rating▲	One-pole	Two-pole—Common Trip
	Catalogue No.	Catalogue No.

QOB-GFI—QOB QWIK-GARD® Circuit Breaker With Ground Fault Circuit Interrupter—Class A 4-6 mA People Protection. ■

Ampere Rating	120 Vac—10,000 AIR	120/240 Vac—10,000 AIR
	15	QOB115GFI
20	QOB120GFI	QOB220GFI
25	QOB125GFI	QOB225GFI
30	QOB130GFI	QOB230GFI
40	QOB240GFI
50	QOB250GFI
60	QOB260GFI ◆

QOB-VHGFI

Ampere Rating	120 Vac—22,000 AIR	
	15	QOB115VHGFI
20	QOB120VHGFI
25	QOB125VHGFI
30	QOB130VHGFI

QOB-EPD—QOB Equipment protection circuit breakers with 30 mA equipment protection.

Ampere Rating	120 Vac—10,000 AIR	
	15	QOB115EPD
20	QOB120EPD	QOB220EPD
25	QOB125EPD	QOB225EPD
30	QOB130EPD	QOB230EPD
40	QOB240EPD
50	QOB250EPD
60	QOB260EPD

QOB-HM—High magnetic trip circuit breakers are recommended for applications where high initial inrush may occur and for individual dimmer applications.

15	QOB115HM□
20	QOB120HM□

QOB-AFI—QOB Arc Fault Circuit Interrupters

15	QOB115AFI
20	QOB120AFI

22,000 AIR

15	QOB115VHAFI
20	QOB120VHAFI

QOB-CAFI—QOB Combination Arc Fault Circuit Interrupters

Ampere Rating	1 Pole 120 Vac	2 Pole 120/240 Vac
	15	QOB115CAFI
20	QOB120CAFI	QOB220CAFI

22,000 AIR

15	QOB115VHCAFI	QOB215VHCAFI
20	QOB120VHCAFI	QOB220VHCAFI

QOB-DF—QOB Dual Function Circuit Breakers

Ampere Rating	1 Pole 120 Vac Pigtail Neutral	1 Pole 120 Vac Plug-On Neutral
	15	QOB115DF
20	QOB120DF	QOB120PDF

22,000 AIR

15	QOB115VHDF	QOB115VHPDF
20	QOB120VHDF	QOB120VHPDF

QOB-K—Key operated QOB circuit breakers can be turned ON or OFF or to RESET with a special key (Catalogue No. QOK10) included with the circuit breaker.

Ampere Rating	120 Vac—10,000 AIR	
	10	QOB110K
15	QOB115K
20	QOB120K
25	QOB125K
30	QOB130K

QO/QOB Circuit Breaker Wire Sizes

Breaker Type	Ampere Rating	Wire Size (AWG)	
		Al	Cu
QOB 1-pole	10-30	#14-8	#14-8
	10-30	(2) #14-10
	35-70	#8-2	#8-2
QOB 2-pole	10-30	#14-8	#14-8
	10-30	(2) #14-10
	35-70	#8-2	#8-2
	80-125	#4-2/0	#4-2/0
	150-200	#4-300 kcmil	#4-300 kcmil
QOB 3-pole	10-30	#14-8	#14-8
	35-70	#8-2	#8-2
	80-125	#4-2/0	#4-2/0
QOB-VH	110-150	#4-300 kcmil	#4-300 kcmil
QOT	15-20	#12-8	#14-8
QOB-GFI & QOB-EPD	15-30	#12-8	#14-8
	40, 50, 60	#12-4	#14-6

Ampere Rating	One-pole	Two-pole—Common Trip	Two-pole—Common Trip★	Three-pole—Common Trip
	Catalogue No.	Catalogue No.	Catalogue No.	Catalogue No.

QOB Bolt-On

Ampere Rating	120 Vac—10,000 AIR	120/240 Vac—10,000 AIR	240 Vac—10,000 AIR	240 Vac—10,000 AIR
	48 Vdc—5,000 AIR	48 Vdc—5,000 AIR ▼		48 Vdc—5,000 AIR ▼
10	QOB110	QOB210	QOB310
15	QOB115△□	QOB215△	QOB215H	QOB315△
20	QOB120△□	QOB220△	QOB220H	QOB320△
25	QOB125△	QOB225△	QOB225H	QOB325△
30	QOB130△	QOB230△	QOB230H	QOB330△
35	QOB135△	QOB235△	QOB335△
40	QOB140△	QOB240△	QOB240H	QOB340△
45	QOB145△	QOB245△	QOB345△
50	QOB150△	QOB250△	QOB250H	QOB350△
60	QOB160△	QOB260△	QOB260H	QOB360△
70	QOB170△	QOB270△	QOB270H	QOB370△ ▼
80	QOB280△ ▼	QOB280H	QOB380△ ▼
90	QOB290△ ▼	QOB290H	QOB390△ ▼
100	QOB2100△ ▼	QOB2100H	QOB3100△ ▼
110	QOB2110△ ▼
125	QOB2125△ ▼

Molded Case Switch 60 A max - 240 Vac

Molded Case Switch 100 A max - 240 Vac

QOB200

QOB2000

QOB300

QOB3000

QOB-VH

Ampere Rating	120 Vac—22,000 AIR	120/240 Vac—22,000 AIR		240 Vac—22,000 AIR
	15	QOB115VH△□	QOB215VH△
20	QOB120VH△□	QOB220VH△	QOB320VH△
25	QOB125VH△	QOB225VH△	QOB325VH△
30	QOB130VH△	QOB230VH△	QOB330VH△
40	QOB240VH△	QOB340VH△
50	QOB250VH△	QOB350VH△
60	QOB260VH△	QOB360VH△
70	QOB270VH△	QOB370VH△
80	QOB280VH△	QOB380VH△
90	QOB290VH△	QOB390VH△
100	QOB2100VH△ ◆	QOB3100VH△
110	QOB2110VH△ ◆	QOB3110VH★
125	QOB2125VH△ ◆	QOB3125VH★
150	QOB2150VH★	QOB3150VH★

QHB

Ampere Rating	120 Vac—65,000 AIR	120 Vac/240 Vac—65,000 AIR		240 Vac—65,000 AIR
	15	QHB115△□	QHB215△
20	QHB120△□	QHB220△	QHB320△
25	QHB125△	QHB225△	QHB325△
30	QHB130△	QHB230△	QHB330△

QOB-HID—HID circuit breakers are for use on circuit feeding fluorescent and High Intensity Discharge (HID) lighting systems such as mercury vapor, metal halide, or high pressure sodium.

Ampere Rating	120 Vac—10,000 AIR	120/240 Vac—10,000 AIR		240 Vac—10,000 AIR
	15	QOB115HID□	QOB215HID
20	QOB120HID□	QOB220HID	QOB320HID
25	QOB125HID	QOB225HID	QOB325HID
30	QOB130HID	QOB230HID	QOB330HID
40	QOB140HID	QOB240HID
50	QOB150HID	QOB250HID

QOB-SWN—Switch Neutral—Common Trip—NEC 514-5

Ampere Rating		1-pole—2-Wire 2 Spaces—120 Vac		2-pole—3-Wire 3 Spaces—120/240 Vac
	10	QOB210SWN
15	QOB215SWN	QOB315SWN
20	QOB220SWN	QOB320SWN
25	QOB225SWN	QOB325SWN
30	QOB230SWN	QOB330SWN
40	QOB240SWN	QOB340SWN
50	QOB250SWN	QOB350SWN

QO/QOB Ring Terminal (20% Price Adder) Factory Installed Only

Ampere Rating	Pole	Suffix
10-30	1P, 2P, 3P	5237
35-60	1P, 2P	5238
35-50	3P	5238
70-110	2P	5273
60-100	3P	5273

▲ 10-30 ampere circuit breakers are suitable for use with 60°C or 75°C conductors. 35-60 ampere circuit breakers are suitable for use with 75°C conductors.

■ Do not connect to more than 250 feet of load conductor for the total one-way run to prevent nuisance tripping.

◆ Suitable only for feeding 240 Vac and 208 Vac two-wire loads. Does not contain load neutral connection.

★ CSA Listed 5,000 AIR on 3Ø corner grounded delta systems.

▼ DC Rating is not available on indicated products.

△ CSA Listed as HACR type for use with air conditioning, heating and refrigeration equipment having motor group combinations and marked for use with HACR type circuit breakers.

□ CSA Listed as SWD (switching duty) rated suitable for switching 120 Vac fluorescent lighting loads.

◇ 100 A max circuit breaker mounted opposite.

★ QOB2150VH uses 4 pole spaces. QOB3110VH, QOB3125VH and QOB3150VH each use 6 pole spaces. 20 A max circuit breaker mounted opposite. Wire size is #4-300 kcmil Al/Cu. Use with 75°C wire only.

See page DE5-5 for accessories.

Panelboards – Ready To Install (RTI)

Accessories

QO/QOB Breaker Accessories - Field Installed

Handle Attachments	Description	Catalogue Number
Handle Tie	Converts any two adjacent 120/20Vac single pole QOB breakers to independent trip two-pole.	QO1HT
	three-pole	QO3HT
Handle Lock-off	Clip for fixing QOB single pole handle in ON or OFF position.	QO1LO
	Clip for fixing QOB 1, 2 or 3-pole breaker handles in ON or OFF position.	HLO1
Handle Padlock Attachment	For padlocking single pole QOB breaker in ON or OFF position.	
	Loose attachment.....	QOHPL
	Fixed attachment.....	QO1PA
	For 2 and 3-pole QOB breakers which require padlocking in either ON or OFF position.	
	Loose Attachment	QO1HPL
	Fixed Attachment	QO1PL
	For padlocking 2-pole QOB-GFI in either ON or OFF position.	GFI2PA
Mechanical Interlock Attachment	For interlocking the handles of two 2-pole or one 2-pole and one 1-pole QOB breakers mounted side-by-side so that only one breaker can be ON at a time.	QO2DTI

QO/QOB Breaker Accessories - Factory Installed▲

Device	Description	Available On Breaker...	Suffix
Shunt Trip	• Breaker trips when power is applied.	QOB, PL	1021
	• Includes a coil clearing contact.		
Auxiliary Contact A	• 240 Vac max., 90 Vac min..		
	• 24 Vac / Vdc max., 9 Vac / Vdc min..	QOB, PL	1042
Auxiliary Contact B	• Closed when breaker is ON.	QOB, GFI, EPD, PL	1200
	• 120 Vac, 5 A max.		
Alarm Switch	• Closed when breaker is OFF or TRIPPED.	QOB, GFI, EPD, PL	1201
	• 120 Vac, 5 A max..		
Alarm Switch	• Closed when breaker is TRIPPED.	QOB, GFI, EPD, PL	2100
	• 120 Vac, 5 A max.		

▲ One per breaker, requires one additional pole space. Terminals for (2) # 14 - 12 Cu.

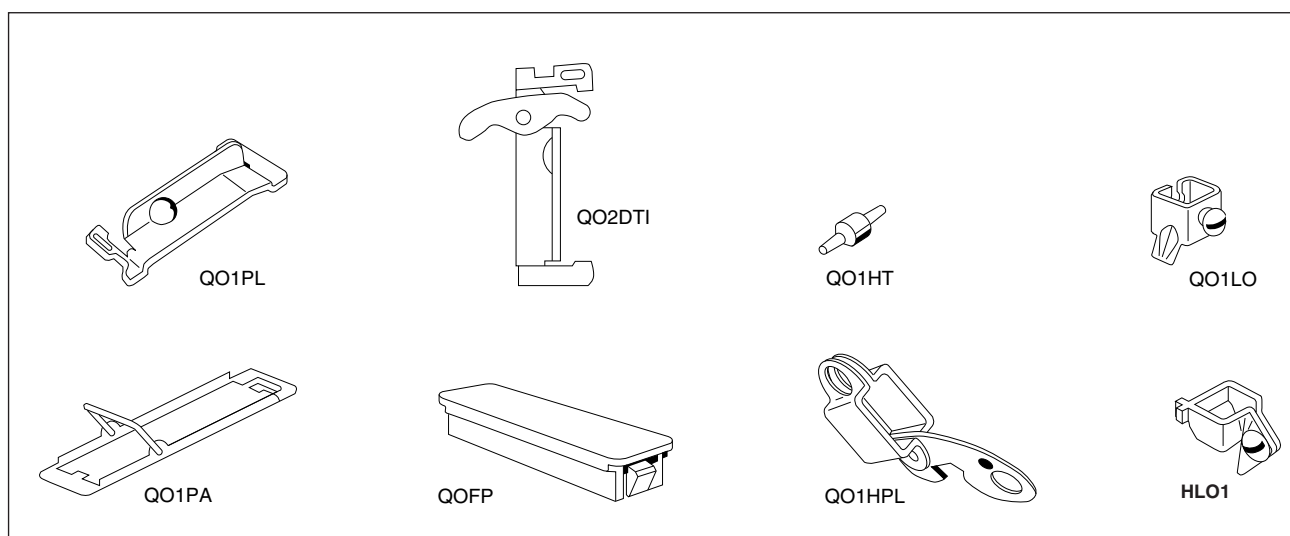

DE5
PANELBOARDS

NQ Panelboards – Ready to Install (RTI)

20" Wide Enclosures—240 Vac, 48 Vdc

NQ Ready to Install Main Lug Interiors

Main Circuit Breaker Interior, Order MLO Interior + MCB Mounting Kit + MCB

Mains Rating	Max no. of Single Pole QO/QOB Circuit Breakers	Interior Only (order branch circuit breakers separately)	Type 1 Enclosure		Type 3R, 5, 12 Enclosure*	
			Box 20"W x 5.75"D■	Front †	Box 20"W x 6.5"D	
			Catalogue No.▲	Catalogue No.	Catalogue No.	Height (in.)
NQ RTI 20" wide Single Phase 3-Wire						
100	18	NQ18L1	MH26	NC26(S) or (F)	MH26WP	26
	18	NQ18L1C	MH26	NC26(S) or (F)	MH26WP	26
	30	NQ30L1	MH32	NC32(S) or (F)	MH32WP	32
	30	NQ30LIC	MH32	NC32(S) or (F)	MH32WP	32
225	30	NQ30L2	MH32	NC32(S) or (F)	MH32WP	32
	30	NQ30L2C	MH32	NC32(S) or (F)	MH32WP	32
	42	NQ42L2	MH38	NC38(S) or (F)	MH38WP	38
	42	NQ42L2C	MH38	NC38(S) or (F)	MH38WP	38
	72	NQ72L2	MH44	NC44(S) or (F)	MH44WP	44
	72	NQ72L2C	MH44	NC44(S) or (F)	MH44WP	44
	84	NQ84L2	MH50	NC50(S) or (F)	MH50WP	50
	84	NQ84L2C	MH50	NC50(S) or (F)	MH50WP	50
400	30	NQ30L4	MH50	NC50V(S) or (F)	MH50WP	50
	30	NQ30L4C	MH50	NC50V(S) or (F)	MH50WP	50
	42	NQ42L4	MH50	NC50V(S) or (F)	MH50WP	50
	42	NQ42L4C	MH50	NC50V(S) or (F)	MH50WP	50
600♦	30	NQ30L6C	MH50	NC50V(S) or (F)	MH62WP**	62
	42	NQ42L6C	MH50	NC50V(S) or (F)	MH62WP**	62
	84	NQ84L6C	MH68	NC68V(S) or (F)	MH80WP**	80
	84	NQ84L6C	MH68	NC68V(S) or (F)	MH80WP**	80
NQ RTI 20" wide Three Phase 4-Wire						
100	18	NQ418L1	MH26	NC26(S) or (F)	MH26WP	26
	18	NQ418L1C	MH26	NC26(S) or (F)	MH26WP	26
	30	NQ430L1	MH32	NC32(S) or (F)	MH32WP	32
	30	NQ430LIC	MH32	NC32(S) or (F)	MH32WP	32
225	30	NQ430L2	MH32	NC32(S) or (F)	MH32WP	32
	30	NQ430L2C	MH32	NC32(S) or (F)	MH32WP	32
	42	NQ442L2	MH38	NC38(S) or (F)	MH38WP	38
	42	NQ442L2C	MH38	NC38(S) or (F)	MH38WP	38
	54	NQ454L2	MH38	NC38(S) or (F)	MH38WP	38
	54	NQ454L2C	MH38	NC38(S) or (F)	MH38WP	38
	72	NQ472L2	MH44	NC44(S) or (F)	MH44WP	44
	72	NQ472L2C	MH44	NC44(S) or (F)	MH44WP	44
400	30	NQ430L4	MH50	NC50V(S) or (F)	MH50WP	50
	30	NQ430L4C	MH50	NC50V(S) or (F)	MH50WP	50
	42	NQ442L4	MH50	NC50V(S) or (F)	MH50WP	50
	42	NQ442L4C	MH50	NC50V(S) or (F)	MH50WP	50
	72	NQ472L4	MH62	NC62V(S) or (F)	MH62WP	62
	72	NQ472L4C	MH62	NC62V(S) or (F)	MH62WP	62
	84	NQ484L4C	MH68	NC68V(S) or (F)	MH68WP	68
	84	NQ484L4C	MH68	NC68V(S) or (F)	MH68WP	68
600♦	30	NQ430L6C	MH50	NC50V(S) or (F)	MH62WP**	62
	42	NQ442L6C	MH50	NC50V(S) or (F)	MH62WP**	62
	84	NQ484L6C	MH68	NC68V(S) or (F)	MH80WP**	80
	84	NQ484L6C	MH68	NC68V(S) or (F)	MH80WP**	80

- ▲ "C" suffix indicates copper bussing.
 - Embossed mounting holes add a .25 inch standoff to back of MH box.
 - ♦ Copper bus standard on 600 A interiors.
 - ★ Enclosure includes trim kit.
 - * Equipment ground bars must be ordered separately.
 - ** Box height may change with subfeed lugs, feed-thru lugs and subfeed breakers.
- Order SurgeLoc SPD for surge suppression on all NQ interiors. Refer to DE5-8.

- * NCxxV(S) or (F) is a vented trim used on 400 & 600 amp NQ.
- * NCxx(S) or (F) is a non vented trim used on 100A & 225A NQ.
- ** Requires the 12 in. rail extension and deadfront NQ12RDE.



NQ 225A 42CCT MLO



NQ SurgeLoc SPD

NQ Panelboards – Ready to Install (RTI)

20" Wide Enclosures — 240 Vac, 48 Vdc

NQ Ready to Install Main Circuit Breaker Box Selection Table

Main Circuit Breaker Interior, Order MLO Interior + MCB Mounting Kit + MCB

Refer to last section on the same page for NQ Service Entrance RTI panels.

(Refer to Section DE3 for Main Breakers)

Mains Rating	Max no. of Single Pole QO/QOB Circuit Breakers	Interior Only (order branch circuit breakers separately) Catalogue No.	Main Vertical Circuit Breaker Information		Type 1 Enclosure		Type 3R, 5, 12 Enclosure
			Kit	Breaker Frames	Box 20"W x 5.75"D	Front	Box 20"W x 6.5"D
					Catalogue No.	Catalogue No.	Catalogue No.
NQ RTI 20" wide Single Phase 3-Wire							
100	18	NQ18L1	NQMB2HJ	HD/HG/HJ/HL 100A max	MH38	NC38(S) or (F)	MH38WP
	18	NQ18L1C			MH38	NC38(S) or (F)	MH38WP
	30	NQ30L1			MH44	NC44(S) or (F)	MH44WP
	30	NQ30LIC			MH44	NC44(S) or (F)	MH44WP
225	30	NQ30L2	NQMB2HJ and desired HD/HG/HJ/HL or JD/JG/JJ/JL breakers - or - NQMB2Q and desired QB/QD/QJ/QL breakers.	MH44	NC44(S) or (F)	MH44WP	
	30	NQ30L2C		MH44	NC44(S) or (F)	MH44WP	
	42	NQ42L2		MH50	NC50(S) or (F)	MH50WP	
	42	NQ42L2C		MH50	NC50(S) or (F)	MH50WP	
	72	NQ72L2		MH56	NC56(S) or (F)	MH56WP	
	72	NQ72L2C		MH56	NC56(S) or (F)	MH56WP	
400	84	NQ84L2	NQMB4LA	LA/LH	MH62	NC62(S) or (F)	MH62WP
	84	NQ84L2C			MH62	NC62(S) or (F)	MH62WP
	30	NQ30L4			MH62	NC62V(S) or (F)	MH62WP
	30	NQ30L4C			MH62	NC62V(S) or (F)	MH62WP
400	42	NQ42L4	NQMB4LA	LA/LH	MH62	NC62V(S) or (F)	MH62WP
	42	NQ42L4C			MH62	NC62V(S) or (F)	MH62WP
	72	NQ72L4			MH74	NC74V(S) or (F)	MH74WP
	72	NQ72L4C			MH74	NC74V(S) or (F)	MH74WP
600	84	NQ84L4C			MH80	NC80V(S) or (F)	MH80WP
600 A MCB available factory assembled							
NQ RTI 20" wide Three Phase 4-Wire							
100	18	NQ418L1	NQMB2HJ	HD/HG/HJ/HL 100A max	MH38	NC38(S) or (F)	MH38WP
	18	NQ418L1C			MH38	NC38(S) or (F)	MH38WP
	30	NQ430L1			MH44	NC44(S) or (F)	MH44WP
	30	NQ430LIC			MH44	NC44(S) or (F)	MH44WP
225	30	NQ430L2	NQMB2HJ and desired HD/HG/HJ/HL or JD/JG/JJ/JL breakers - or - NQMB2Q and desired QB/QD/QJ/QL breakers.	MH44	NC44(S) or (F)	MH44WP	
	30	NQ430L2C		MH44	NC44(S) or (F)	MH44WP	
	42	NQ442L2		MH50	NC50(S) or (F)	MH50WP	
	42	NQ442L2C		MH50	NC50(S) or (F)	MH50WP	
	54	NQ454L2		MH50	NC50(S) or (F)	MH50WP	
	54	NQ454L2C		MH50	NC50(S) or (F)	MH50WP	
400	72	NQ472L2	NQMB4LA	LA/LH	MH56	NC56(S) or (F)	MH56WP
	72	NQ472L2C			MH56	NC56(S) or (F)	MH56WP
	84	NQ484L2			MH62	NC62(S) or (F)	MH62WP
	84	NQ484L2C			MH62	NC62(S) or (F)	MH62WP
400	30	NQ430L4	NQMB4LA	LA/LH	MH62	NC62V(S) or (F)	MH62WP
	30	NQ430L4C			MH62	NC62V(S) or (F)	MH62WP
	42	NQ442L4			MH62	NC62V(S) or (F)	MH62WP
	42	NQ442L4C			MH62	NC62V(S) or (F)	MH62WP
400	72	NQ472L4	NQMB4LA	LA/LH	MH74	NC74V(S) or (F)	MH74WP
	72	NQ472L4C			MH74	NC74V(S) or (F)	MH74WP
	84	NQ484L4			MH80	NC80V(S) or (F)	MH80WP
	84	NQ484L4C			MH80	NC80V(S) or (F)	MH80WP
600 A MCB available factory assembled							

DE5
PANELBOARDS

NQ RTI Service Entrance Main Breaker and Main Lug Panelboards

Mains Rating	1 phase or 3 phase	max # of single pole QO/QOB circuit breakers	Factory installed Main Breaker	Catalogue Number	Type 1 Enclosure Width	Surface or Flush-Mount Trim
100A	3 phase	42	QBL32100	NQSE342100S	14"	S
				NQSE342100F	14"	F
200A	3 phase	42	QBL32200	NQSE342200S	14"	S
				NQSE342200F	14"	F
225A	3 phase	42	n/a	NQML342225S*	14"	S
400A	1 phase	42	LAL26400	NQSE142400F	20"	F
	3 phase	42	LAL36400	NQSE342400S	20"	S
	1 phase	84	LAL26400	NQSE184400F	20"	F
	3 phase	72	LAL36400	NQSE372400S	20"	S

Note: no field-installable kits available for above listed RTI SE MB or ML Panelboards

* 225A Main lug device - Not Service Entrance rated.

NQ Panelboards – Ready to Install (RTI)

20" Wide Enclosures — 240 Vac, 48 Vdc

NQ

RTI Optional Main Lug Kits for NQ Main Lug Panelboards

Amps	Aluminum				Copper			
	Aluminum Mechanical		Aluminum Compression		Copper Mechanical		Copper Compression	
	Cat. #	Lug Wire Range for wire bending space	Cat. #	Lug Wire Range for wire bending space	Cat. #	Lug Wire Range for wire bending space	Cat. #	Lug Wire Range for wire bending space
100	NQALM1	(1) #6 - 350 MCM	NQALV1	(1) #4-300 kcmil	NQCUM1	(1) #6 - 350 kcmil	NQCUV1	(1) #6 - 350 kcmil
225	NQALM2	(1) #6 - 350 MCM	NQALV2	(1) 250-350 kcmil	NQCUM2	(1) #6 - 350 kcmil	NQCUV2	(1) #6 - 350 kcmil
400	NQALM4	(1) 1/0-750 MCM or (2) 1/0-350 MCM	NQALV4	(2) 2/0-500 kcmil	NQCUM4	(1) 1/0-750 kcmil or (2) 1/0-350 kcmil	NQCUV4	(1) 400-750 kcmil
600	NQALM6	(2) 1/0-750 MCM	NQALV6	(2) 2/0-500kcmil	NQCUM6	(2) 1/0-750 kcmil	NQCUV6	(2) 250-500 kcmil
600 ^a	NQALM6A	(3) 1/0-250 MCM		---	---	---	---	---

a. Optional lug for 600A. Can also be used for 400A.

NQ RTI Accessories Main Breaker Kits and 200% Neutrals

Main Breaker Kits				200% Neutrals				
Mains Ampacity	Main Breaker Kit (less circuit breaker)			Mains Ampacity	200% Neutral Kit		Copper 100% Neutral Kit	
	Catalogue No.	Fits Breaker Frames	Add Box Ht		Catalogue No.	Add Box Ht	Catalogue No.	Add Box Ht
100	NQMB2HJ	H 100 A max	12"	100	NQNL1	no adder	100A NQN1CU	no adder
225	NQMB2HJ	H 150 A max and J 225A max		225	NQNL2 or NQNL2ACCY **		225A NQN2CU	
	NQMB2Q	Q 225 A max					400A NQN6CU	
400	NQMB2KI	KI 225 A max		600A NQN6CU *				
400	NQMB4LA	LAL/LHL (LC F/A only.)	600	NQNL4 *				
600		Factory Assembled Only						

* Not to be used with SFL, FTL or SFB. These combinations - Factory Assembled Only.
 ** For 225A panel with SFL, FTL or SFB, use NQNL2ACCY.

Sub Feed Lugs, Feed-Through Lugs and Sub Feed Breakers

Mains Ampacity	Sub Feed Lugs (N/A in MCB Interiors)	Feed-thru Lugs	Sub Feed Circuit breaker kits (breaker not included)	
			Single SFB	Two SFBs
	Catalogue No.	Catalogue No.	Catalogue No.	Catalogue No.
100	NQSFL1	100A Not Available, Use 225A Interior	---	---
225	NQSFL2	NQFTL2L (a)	NQSFB2Q or NQSFB2HJ	---
		NQFTL2H (b)		---
400	NQSFL4	NQFTL4L (a)	NQSFB4Q or NQSFB4HJ	---
		NQFTL4H (b)		---
600		Factory Assembled Only		

(a) final character L indicates the kit is used for low circuit count interiors 30-42 cct
 (b) final character H indicates the kit is used for high circuit count interiors 54, 72 and 84 cct

NQ SurgeLoc Surge Protection

Voltage	Surge Current per Phase	Modes of Protection	Configuration	Model Number
120/240V	80kA	6	1 phase, 3 wire + ground	SSP01BIA08PBQ1
208Y/120V	80kA	10	3 phase, Wye, 4-wire + ground	SSP02BIA08PBQ1
120/240V	100kA	6	1 phase, 3 wire + ground	SSP01BIA10PBQ1
208Y/120V	100kA	10	3 phase, Wye, 4-wire + ground	SSP02BIA10PBQ1
120/240V	120kA	6	1 phase, 3 wire + ground	SSP01BIA12PBQ1
208Y/120V	120kA	10	3 phase, Wye, 4-wire + ground	SSP02BIA12PBQ1
120/240V	160kA	6	1 phase, 3 wire + ground	SSP01BIA16PBQ1
208Y/120V	160kA	10	3 phase, Wye, 4-wire + ground	SSP02BIA16PBQ1
120/240V	200kA	6	1 phase, 3 wire + ground	SSP01BIA20PBQ1
208Y/120V	200kA	10	3 phase, Wye, 4-wire + ground	SSP02BIA20PBQ1
120/240V	240kA	6	1 phase, 3 wire + ground	SSP01BIA24PBQ1
208Y/120V	240kA	10	3 phase, Wye, 4-wire + ground	SSP02BIA24PBQ1
240-120HLD	80kA	10	3 phase, HLD, 4-wire + ground	SSP03BIA08PBQ1
240-120HLD	100kA	10	3 phase, HLD, 4-wire + ground	SSP03BIA10PBQ1
240-120HLD	120kA	10	3 phase, HLD, 4-wire + ground	SSP03BIA12PBQ1
240-120HLD	160kA	10	3 phase, HLD, 4-wire + ground	SSP03BIA16PBQ1
240-120HLD	200kA	10	3 phase, HLD, 4-wire + ground	SSP03BIA20PBQ1
240-120HLD	240kA	10	3 phase, HLD, 4-wire + ground	SSP03BIA24PBQ1

Note: The 208Y/120V SurgeLoc SPD series also applies to the voltage 220Y/127V

Note: When selecting a panelboard with a SurgeLoc SPD, an additional 12 circuit positions (6 adjacent mounting spaces per side) or 4.5 inches of space on each side are required. For example, if desired number of circuits is 30, a 42 circuit panelboard is required.

Note: SurgeLoc SPDs are only available in Type 1 SPD format.



NQ SurgeLoc SPD

NQ Panelboards – Ready to Install (RTI)

20" Wide Enclosures — 240 Vac, 48 Vdc

NQ

Box Sizing Requirements

Basic NQ MLO Panelboard Enclosure Sizes and Height Adders for Accessories

Mains Rating	Available Branch Circuits	Required Enclosure Height (in.)	Interior Only		Type 1 Enclosure		3R/5/12 Complete Enclosure	Space Factor (height adder for feature)				
			Single Phase	Three Phase	Box	Trim		Vertical MCB	AI SFL	FTL	SFB	200% Neutral
100	18	26	NQ18L1	NQ18L1	MH26	NC26()	MH26WP	12"	0"	0"	Not Available	0"
	30	32	NQ30L1	NQ30L1	MH32	NC32()	MH32WP					
225	30	32	NQ30L2	NQ30L2	MH32	NC32()	MH32WP	12"	6" (Cu=0")	6"	18"	0"
	42	38	NQ42L2	NQ42L2	MH38	NC38()	MH38WP					
	54	38	NQ54L2	NQ54L2	MH38	NC38()	MH38WP					
	72	44	NQ72L2	NQ72L2	MH44	NC44()	MH44WP					
400	30	50	NQ30L4	NQ30L4	MH50	NC50V()	MH50WP	12"	0	0"	24"	0"
	42	50	NQ42L4	NQ42L4	MH50	NC50V()	MH50WP					
	54	56	NQ54L4	NQ54L4	MH56	NC56V()	MH56WP					
	72	62	N/A	NQ472L4	MH62	NC62V()	MH62WP					
600	30	50	NQ30L6C	NQ30L6C	MH50	NC50V()	MH62WP	18" (LC/LI)	Not Available	6" on each end - total 12"	24"	Not Available
	42	50	NQ42L6C	NQ42L6C	MH50	NC50V()	MH62WP					
	54	56	NQ54L6C	NQ54L6C	MH56	NC56V()	MH68WP					
	72	62	N/A	NQ472L6C	MH62	NC62V()	MH74WP					
84	68	68	NQ84L6C	NQ84L6C	MH68	NC68V()	MH80WP					

Example:

NQ 225A 30 circuit MCB Panelboard with FTL in Type 1 surface enclosure:

Basic interior: 32"

MCB adder: 12"

FTL adder: 6"

Required height: 50" Box MH50, trim NC50S

NQ RTI Accessories

Description	Application	Catalogue No.
Equipment Ground Bars	Aluminum	PK27GTA
	Copper	PK27GTACU
	Insulator Kit	PKGTAB
PK23GTA + #1 to #4/0 Al/Cu lug	Ground Bar with Lug	PK23GTAL
Filler Plate (15 per package)	Plastic Filler	NQFP15
Directory Cards	NQ Panelboard	80031 158 01
Plastic stick-on directory pouch	NQ Panelboard	80031 159 01
Circuit Numbering Strips	Odd-Even 1-102	NQ102OE
	Sequential 1-102	NQ102S
	Odd-Even 103-204	NQ204OE
	Sequential 103-204	NQ204S
Key - NSR-251	NEMA 1Locks	LP9618
Key - DSR-251	NEMA 3R Locks	DSR-251
Rail and Deadfront extensions	6" Extension	NQ6RDE
	12" Extension	NQ12RDE
	18" Extension	NQ18RDE
	24" Extension	NQ24RDE
Handle Padlock Attachment	Branches	See Circuit Breaker Section
Mounting Nut (4 per pkg.)	Interiors	23220 00003
Elevating Kit	Flush only	NQLN
Trim mounting screws / hardware		
250A Max. Interiors (10 per pkg.)		NFTMS1
400A/600A Interiors (8 per pkg.)		LP9502
Branch mount bolt-on sub-feed	2-pole	QOB2125SL
	3-pole	QOB3125SL
Drip Hood for std encl.	20" Wide	MHT2DH20

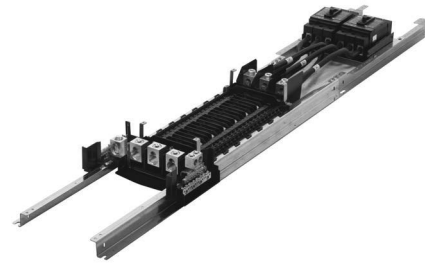

NQ 400A 42CCT MLO w/2 subfeed CB's

DE5 PANELBOARDS

NQ Panelboards – Ready to Install (RTI)

NQ 14" Wide — 240 Vac, 48 Vdc

Main lug Interiors — Accepts Plug-On and Bolt-On Branch Breakers

Max. of breakers	Main Ratings	Interior Only (Order Branch Circuit Breakers Separately) Catalogue No.	Type 1 Enclosure	
			Box 14"W x 5.75" D Catalogue No.	Mono Flat Front Δ ◆ Catalogue No.
14" Wide Cabinet — Single Phase 3-Wire				
18	100 A	NQ18L1C14	NQB532	NQC32()
30		NQ30L1C14	NQB532	NQC32()
30	225 A	NQ30L2C14	NQB532	NQC32()
42		NQ42L2C14	NQB538	NQC38()
14" Wide Cabinet — Three Phase 4-Wire				
18	100 A	NQ418L1C14	NQB532	NQC32()
30		NQ430L1C14	NQB532	NQC32()
30	225 A	NQ430L2C14	NQB532	NQC32()
42		NQ442L2C14	NQB538	NQC38()

Main Circuit Breaker Interiors — Accepts Plug-On and Bolt-On Branch Breakers

Max. of breakers	Main Ratings	Interior Only (Order Branch Circuit Breakers Separately) Catalogue No.	Main Circuit Breaker Adapter Kit (Less Circuit Breaker) \blacktriangle Catalogue No.	Type 1 Enclosure		
				Box 14"W x 5.75" D		Mono Flat Front Δ ◆ Catalogue No.
14" Wide Cabinet — Single Phase 3-Wire						
16 *	100 back-fed	NQ18L1C14	-	Select QOB 2-pole or QOB-VH	NQB532	NQC32()
28 *		NQ30L1C14	-		NQB532	NQC32()
30	225	NQ30L2C14	NQMB2HJ14 or NQMB2Q14	HD, HG, HJ, HL, OR JD, JG, JJ, JL, QB, QD, QG, QJ	NQB544	NQC44()
42		NQ42L2C14			NQB550	NQC50()
14" Wide Cabinet — Three Phase 4-Wire						
15 *	100 back-fed	NQ418L1C14	-	Select QOB 3-pole or QOB-VH	NQB532	NQC32()
27 *		NQ430L1C14	-		NQB532	NQC32()
30	225	NQ430L2C14	NQMB2HJ14 or NQMB2Q14	HD, HG, HJ, HL, OR JD, JG, JJ, JL, QB, QD, QG, QJ	NQB544	NQC44()
42		NQ442L2C14			NQB550	NQC50()

- * Pole spaces shown are available for branch circuits, with spaces deducted for the back-fed main breaker.
- Δ Add "F" for flush, "S" for surface.
- \blacktriangle Select the appropriate main circuit breaker and add the circuit breaker price to the total price of the panelboard.
- ◆ Embossed mounting holes add a 0.25" standoff to back of MH box.

DE5 PANELBOARDS

NF Panelboards – Ready to Install (RTI)

Branch Circuit Breakers



EDB, EGB, EJB
1-pole
15–70 Amperes



EDB, EGB, EJB
2-pole
15–110 Amperes



EDB, EGB, EJB
3-pole
15–100 Amperes

E-frame—110 A, Thermal-magnetic (600Y/347 Vac)

Cont. Current Rating @ 40°C	AC Magnetic Trip Settings		“D” Interrupting Level 14 kA @ 600Y/347 Vac	“G” Interrupting Level 18 kA @ 600Y/347 Vac	“J” Interrupting Level 25 kA @ 600Y/347 Vac	Standard Lug Wire Range
	Hold	Trip	Catalogue Number	Catalogue Number	Catalogue Number	
1-pole, 347 Vac						
15	270	875	EDB16015■	EGB16015▲■	EJB16015▲■	#12–#6 AWG Al or #14–#6 AWG Cu
20	270	875	EDB16020■	EGB16020▲■	EJB16020▲■	
25	270	875	EDB16025■	EGB16025■	EJB16025■	
30	270	875	EDB16030■	EGB16030■	EJB16030■	
35	630	1800	EDB16035	EGB16035	EJB16035	#12–#2/0 AWG Al or #14–#2/0 AWG Cu
40	630	1800	EDB16040	EGB16040	EJB16040	
45	630	1800	EDB16045	EGB16045	EJB16045	
50	630	1800	EDB16050	EGB16050	EJB16050	
60	630	1800	EDB16060	EGB16060	EJB16060	
70	630	1800	EDB16070	EGB16070	EJB16070	
70	630	1800	EDB16070	EGB16070	EJB16070	
2-pole, 600Y/347 Vac ♦						
15	270	875	EDB26015■	EGB26015■	EJB26015■	#12–#6 AWG Al or #14–#6 AWG Cu
20	270	875	EDB26020■	EGB26020■	EJB26020■	
25	270	875	EDB26025■	EGB26025■	EJB26025■	
30	270	875	EDB26030■	EGB26030■	EJB26030■	
35	630	1800	EDB26035	EGB26035	EJB26035	#12–#2/0 AWG Al or #14–#2/0 AWG Cu
40	630	1800	EDB26040	EGB26040	EJB26040	
45	630	1800	EDB26045	EGB26045	EJB26045	
50	630	1800	EDB26050	EGB26050	EJB26050	
60	630	1800	EDB26060	EGB26060	EJB26060	
70	630	1800	EDB26070	EGB26070	EJB26070	
80	1000	2300	EDB26080	EGB26080	EJB26080	
90	1000	2300	EDB26090	EGB26090	EJB26090	
100	1000	2300	EDB26100	EGB26100	EJB26100	
110	1000	2300	EDB26110	EGB26110	EJB26110	
3-pole, 600Y/347 Vac						
15	270	875	EDB36015■	EGB36015■	EJB36015■	#12–#6 AWG Al or #14–#6 AWG Cu
20	270	875	EDB36020■	EGB36020■	EJB36020■	
25	270	875	EDB36025■	EGB36025■	EJB36025■	
30	270	875	EDB36030■	EGB36030■	EJB36030■	
35	630	1800	EDB36035	EGB36035	EJB36035	#12–#2/0 AWG Al or #14–#2/0 AWG Cu
40	630	1800	EDB36040	EGB36040	EJB36040	
45	630	1800	EDB36045	EGB36045	EJB36045	
50	630	1800	EDB36050	EGB36050	EJB36050	
60	630	1800	EDB36060	EGB36060	EJB36060	
70	630	1800	EDB36070	EGB36070	EJB36070	
80	1000	2300	EDB36080	EGB36080	EJB36080	
90	1000	2300	EDB36090	EGB36090	EJB36090	
100	1000	2300	EDB36100	EGB36100	EJB36100	

All EDB, EGB, and EJB circuit breakers are cUL Listed as HACR Type.
 ▲ cUL Listed as SWD (Switching duty rated).
 ■ cUL Listed as HID (High Intensity Discharge rated).
 ♦ cUL Listed for use on 240 V Corner-grounded Delta Systems (Grounded B Phase).

Interrupting Ratings (kA)

	EDB	EGB	EJB
120 V	25	65	100
240 V	18 (1P), 25	35 (1P), 65	65 (1P), 100
480Y/277 V	18	35	65
600Y/347 V	14	18	25

Branch Circuit Breaker Interrupting Capacity

Circuit Breaker Frame Type	No. of Poles	Contin-uous Ampere Rating	UL Listed Interrupting Rating-RMS Symmetrical Amperes					
			AC Volts, 50/60 Hz					
			120	120/240	240	277	480Y/347	600Y/347
EDB	1	15-70 A	25 k	25 k	18 k	18 k	-	14 k
	2, 3	15-125 A▲	25 k	25 k	25 k	-	18 k	14 k
EGB	1	15-70 A	65 k	65 k	35 k	35 k	-	18 k
	2, 3	15-125 A▲	65 k	65 k	65 k	-	35 k	18 k
EJB	1	15-70 A	100 k	100 k	65 k	65 k	-	25 k
	2, 3	15-125 A▲	100 k	100 k	100 k	-	65 k	25 k

▲ 110 A maximum at 600Y/347 Vac

Factory installed Electrical Accessories

Auxiliary Switch (1A/1B)	Alarm Switch (NO)	Coil Burden Max. (VA)	Minimum Recommended Supply Transformer (VA)
		288	50
Monitors circuit breaker contact status and provides a remote signal indicating the circuit breaker contacts are OPEN or CLOSED.	Used with control circuits and is activated only when the circuit breaker has tripped.	Shunt Trip Trips the circuit breaker from a remote location by means of a coil energized from a separate circuit. A 120 V shunt trip will operate at 55% or more of rated voltage.	
APPLICATION Max Load = 10 A @ 120 Vac 50/60 Hz Terminals for #14 AWG Cu wire.	APPLICATION Max Load = 7 A @ 120 Vac 50/60 Hz Terminals for #14 AWG Cu wire.	APPLICATION For use with momentary or maintained push button. 120 Vac 50/60 Hz Terminals for #14 AWG Cu wire.	

Note: Handle padlock attachment part number HPAFD available for order separately.

DE5
PANELBOARDS

NF Panelboards – Ready to Install (RTI)

20" Wide Enclosures—600Y/347 Vac Max.

NF Main Lug Interiors

Use I-LINE® Panelboards on 600 V 3Ø3W systems

Single Phase 3-Wire – Available Factory Assembled Only

Three Phase 4-Wire

Mains Rating (Amps) (4)	Max No. of Circuits	Interior only (order branch circuit breakers separately)	Enclosure			Height (in)
			Type 1		Type 3R, 12	
			Box 20" W x 5.75" D	Mono Flat Front (F) flush (S) surface (3)	Enclosure & Trim 20" W x 6.5" D	
		Catalogue No.	Catalogue No.	Catalogue No.	Catalogue No.	
125	18	NF418L1	MH26	NC26()	MH26WP	26
	18	NF418L1C	MH26	NC26()	MH26WP	26
	30	NF430L1	MH32	NC32()	MH32WP	32
	30	NF430LIC	MH32	NC32()	MH32WP	32
250	30	NF430L2	MH38	NC38()	MH38WP	38
	30	NF430L2C	MH38	NC38()	MH38WP	38
	42	NF442L2	MH44	NC44()	MH44WP	44
	42	NF442L2C	MH44	NC44()	MH44WP	44
	54	NF454L2	MH50	NC50()	MH50WP	56
	54	NF454L2C	MH50	NC50()	MH50WP	56
	66	NF466L2	MH62	NC62()	MH62WP	62
	66	NF466L2C	MH62	NC62()	MH62WP	62
400	30	NF430L4	MH50	NC50V()	MH50WP	50
	30	NF430L4C	MH50	NC50V()	MH50WP	50
	42	NF442L4	MH56	NC56V()	MH56WP	56
	42	NF442L4C	MH56	NC56V()	MH56WP	56
	66	NF466L4	MH74	NC74V()	MH74WP	74
	66	NF466L4C	MH74	NC74V()	MH74WP	74
	84	NF484L4	MH86	NC86V()	MH86WP	86
	84	NF484L4C	MH86	NC86V()	MH86WP	86
600	30	NF430L6C	MH50	NC50V()	Factory Assembled Only	50
	42	NF442L6C	MH56	NC56V()		56
	66	NF466L6C	MH74	NC74V()		74
	84	NF484L6C	MH86	NC86V()		86
800	Factory Assembled Only					

- "C" suffix indicates Copper bussing.
- Type 1 enclosure catalogue numbers consist of MH plus the box height (example: MH44).
- Type 3R enclosure catalogue numbers add WP to the Type 1 catalogue number (example: MH44WP).
- Trim catalogue numbers consist of "NC" plus the box height plus "S" for surface trim or "F" for flush trim (example: NC44S).
Trims for 400A and 600A panels are vented and require a "V" after the height in the catalogue number (example: NC62VS).
Add "HR" suffix to part number for hinged trims.
- The maximum total amperage of two branch breakers mounted across from each other is 170A.
- Embossed mounting holes add a 0.25 inch standoff to back of MH box.
- Enclosures types 4 and 4X stainless steel are available factory assembled only.
- Equipment ground bars must be ordered separately.
- Additional panelboards with various maximum circuit numbers are available as Factory-assembled. Please contact your Schneider Electric Sales professional for details.

400A, 42 circuits
Main lug interior with
deadfront



400A interior
Main lugs
close-up

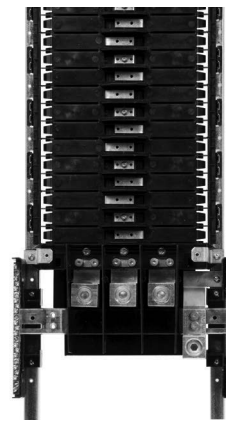

NF Panelboards – Ready to Install (RTI)

20" Wide Enclosures—600Y/347 Vac Max.

NF Main Circuit Breaker Interiors Use I-LINE® Panelboards on 600 V 3Ø3W systems

Single Phase 3-Wire – Available Factory Assembled Only

Three Phase 4-Wire

Mains Rating (Amps) (5)	Max. No. of circuits	Interior	Main Breaker Adapter Kit	Enclosure			Height (in)
				Type 1		Type 3R, 12	
				3 Phase 4 Wire	3 Phase 4 Wire	Box 20" W x 5.75"D	
100 (125A)	18	NF418L1	N100MFI and 3 pole FIL circuit breakers - or - N150MH and desired 3 pole (125A max) HDL, HGL, HJL or HLL breaker	MH38	NC38()	MH38WP	38
	18	NF418L1C		MH38	NC38()	MH38WP	38
	30	NF430L1		MH44	NC44()	MH44WP	44
	30	NF430L1C		MH44	NC44()	MH44WP	44
110 (7)	18	NF418L1	Back-fed Main Breaker (7) No kit needed. Select a 3-pole EDB, EGB or EJB breaker. Uses three poles of mounting space.	MH26	NC26()	MH26WP	26
	18	NF418L1C		MH26	NC26()	MH26WP	26
	30	NF430L1		MH32	NC32()	MH32WP	32
	30	NF430L1C		MH32	NC32()	MH32WP	32
250 (9)	30	NF430L2	N250MKC and desired 3 pole KIL circuit breaker - or - N250MJ and desired 3 pole JDL, JGL, JLL or JLL breaker.	MH50	NC50()	MH50WP	50
	30	NF430L2C		MH50	NC50()	MH50WP	50
	42	NF442L2		MH56	NC56()	MH56WP	56
	42	NF442L2C		MH56	NC56()	MH56WP	56
	54	NF454L2		MH62	NC62()	MH62WP	56
	54	NF454L2c		MH62	NC62()	MH62WP	56
400	66	NF466L2	N400M and desired 3 pole LAL/LHL breakers (LC/LI available F/A only)	MH74	NC74()	MH74WP	74
	66	NF466L2C		MH74	NC74()	MH74WP	74
	30	NF430L4		MH62	NC62V()	MH62WP	62
	30	NF430L4C		MH62	NC62V()	MH62WP	62
	42	NF442L4		MH68	NC68V()	MH68WP	68
	42	NF442L4C		MH68	NC68V()	MH68WP	68
	66	NF466L4		MH86	NC86V()	MH86WP	86
	66	NF466L4C		MH86	NC86V()	MH86WP	86
84		Factory Assembled Only					
84		Factory Assembled Only					

- "C" suffix indicates Copper bussing.
- Select the appropriate main circuit breaker from the breakers section.
- Type 1 enclosure catalogue numbers consist of MH plus the box height (example: MH44).
Type 3R enclosure catalogue numbers add WP to the Type 1 catalogue number (example: MH44WP).
- Trim catalogue numbers consist of "NC" plus the box height plus "S" for surface trim or "F" for flush trim (example: NC44S).
Trims for 400A and 600A panels are vented and require a "V" after the height in the catalogue number (example: NC62VS).
Add "HR" suffix to part number for hinged trims.
- The maximum total amperage of two branch breakers mounted across from each other is 170A.
- Embossed mounting holes add a 0.25 inch standoff to back of MH box.
- In back-fed main breaker application the use of NFBFMB20 barrier is recommended. Please refer to local Electrical Codes or Authorities for specific local requirements.
Maximum 60A branch breaker to be mounted across from a 110A back-fed main breaker.
In back-fed main breaker applications, 2 poles (1P3W) or 3 poles (3P4W) branch mounting space are used up by the back-fed main.
- Equipment ground bars must be ordered separately.
- Additional panelboards with various maximum circuit numbers are available as Factory-assembled. Contact your local Schneider Electric Sales professional for details.

DE5 PANELBOARDS

400A Interior
with vertically
mounted
Main
Breaker



400A Main Lug
interior,
with Field-installable
Main Breaker Kit

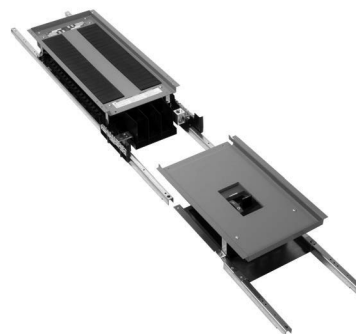

NF Panelboards – Ready To Install (RTI)

Accessories

NF Interiors with TVSS

Mains Rating	Max. No. of circuits	TVSS Ratings		Interior*	Components for adding Vertical Main Circuit Breaker (MCB)	
		Voltage/System	Surge Rating (kA)		MCB Kit Catalogue No.	MCB Frames Select appropriate MCB type
250A	42	480Y/277 3P4W	120	NF442L2TVS412	N250MJ or N250MKC	JD/G/J/L or KIL
		600Y/347 3P4W	160	NF442L2TVS416		
400A	42	480Y/277 3P4W	120	NF442L4TVS412	N400M	LAL/LHL (LC and LI available F/A only.)
		600Y/347 3P4W	160	NF442L4TVS416		
			120	NF442L4TVS812		

* For copper interiors please add "c" suffix to the part number.
Dry contacts standard.

NF with TVSS Box Selection Table

Mains Rating	Max. No. of circuits	Main Lug Panelboard Box Requirements			Main Circuit Breaker Panelboard Box Requirements		
		Type 1 Enclosure		Type 3R, 5, 12 Enclosure	Type 1 Enclosure		Type 3R, 5, 12 Enclosure
		Box	Front*	Enclosure	Box	Front*	Enclosure
250A	42	MH62	NC62()	MH62WP	MH74	NC74()	MH74WP
400A	42	MH74	NC74V()	MH74WP	MH86	NC86V()	MH86WP

* Add "S" for surface or "F" for flush.

Main Breakers and Neutral Kits (breaker not included)

MLO Interior Amps	Main Breaker Kit □		200% Neutral Kit Catalog No.	Copper 100% Neutral Kit Catalog No.
	Catalog No.	Main Breaker Type		
100	N100MFI	FI	NFNL1	NFN1CU
125	N150MH	HD/G/J/L 125A max		
250	N250MJ	JD/G/J/L	NFNL2	NFN2CU
250	N250MKC	KI		
400	N400M	LAL/LHL (LC and LI F/A only)	NFNL4*	NFN6CU
600	Factory Assembled Only			NFN6CU*▲▼
800	MLO Only		Factory Assembled Only	

□ Order appropriate circuit breakers separately.
* Not to be used in combinations with SFL, FTL or SFB. Order Factory assembled only.
▲ Not to be used in type 3R, 4, 4x, 12 enclosures.
▼ Add 6" to box height (except when used with LC/LI MB)

Feed-Thru Lugs

(Standard Aluminum Mechanical Lugs)
A second set of lugs installed at the opposite end from the panelboard mains. Available on main lugs and main circuit breaker panelboards.

Mains Rating (A)	Feed-Thru Wire Range
125	(1) #6-2/0 Al/Cu
250	(1) #6-350 kcmil Al/Cu
400	(1) 1/0-750 kcmil or (2) 1/0-350 kcmil Al/Cu
600	(2) 1/0-600 kcmil Al/Cu

Sub-Feed (Double) Lugs

(Standard Aluminum Mechanical Lugs)
An additional mains end termination point that can be used to feed out to another panelboard or device from the incoming service lines.

Mains Rating (A)	Feed-Thru Wire Range
125	(2) #6-2/0 Al/Cu
250	(2) 1/0-350 kcmil Al/Cu
400	(2) 1/0-600 kcmil Cu
600	(4) 4/0-500 kcmil Al/Cu
800	(3) 3/0-500 kcmil Al/Cu

Sub Feed Lugs, Feed-Thru Lugs and Sub Feed Breakers

Amps	Sub Feed Lugs	Feed-Thru Lugs	Sub Feed Circuit Breaker Kits (breaker not incl.) ●	
	Aluminum	Aluminum	Single SFB	Two SFBs ■
125	NF125SFL	NF125FTL	---	---
250	NF250SFL	NF250FTL	NF250SFBH, NF250SFBJ	---
400	NF400SFL ◆	NF400FTL	---	NF600SFBH, NF600SFBJ
600	Factory Assembled Only		---	NF600SFBH, NF600SFBJ
800	Factory Assembled Only			

● Subfeed breaker kits are using HD/G/J/L or JD/G/J/L breakers respectively. Please order appropriate circuit breakers separately.
◆ Use copper wire only.
■ Available only on 30 and 42 circuit interiors. 400A MLO/MB and 600A MLO.

Box Selection Table: NF Main Lug Panelboards with Accessories (Standard mechanical lugs only)

Circuit #	Amps	Sub Feed Lugs			Feed Through Lugs			Sub Feed Circuit Breakers			
		125 A	250 A	400 A	125 A	250 A	400 A	125 A	250 A	400A	600A
18		MH26	---	---	MH32	---	---	---	---	---	---
30		MH32	MH38	MH50	MH38	MH50	MH56	---	MH56	MH68	MH68
42		---	MH44	MH56	---	MH56	MH62	---	MH62	MH74	MH74
66		---	MH62	MH74	---	MH74	MH80	---	MH80	---	---
84		---	---	MH86	---	---	---	---	---	---	---

Box Selection Table: NF Vertically Mounted Main Breaker Panelboards with Accessories

Circuit #	Amps	Feed Through Lugs				Sub Feed Circuit Breakers				Backfed Main Breaker
		125 A	250 A	400 A●	600A	125 A	250 A	400A●	600A	110A
18		MH44	---	---	---	---	---	---	---	MH32
30		MH50	MH62	MH68	Factory assembled only	---	MH68	MH80	---	MH38
42		---	MH68	MH74	---	---	MH74	MH86	---	---
66		---	MH86	---	---	---	---	---	---	---
84		---	---	---	---	---	---	---	---	---

● 400A dimensions for LA/LH main breakers only. LC/LI mains are available Factory assembled only.

NOTE:

Please contact our Customer Information Centre at 1-800-565-6699 for any questions regarding our Ready to Install or Factory Assembled offer. Various additional NF panelboard sizes and combinations are available exclusively as Factory-Assembled.

NF Panelboards – Ready To Install (RTI)

Accessories

NF Main Neutral Conductors – Required Size and Quantity

Panelboard Ampacity	Neutral Conductors Required	Actual Lug Wire Range
125	(1) #1 Cu, or (1) 2/0 Al	(1) #6-2/0
250	(1) 250 kcmil Cu, or (1) 350 kcmil Al	(1) #6-350 kcmil
400	(1) 600 kcmil Cu, or (2) 3/0 Cu, or (2) 250 kcmil Al	(1) 1/0-750 kcmil (2) 1/0-300 kcmil
600	(2) 350 kcmil Cu, or (2) 500 kcmil Al	(1) 1/0-750 kcmil (2) 1/0-300 kcmil

NF Standard Mechanical Lugs—Main Circuit Breaker

Ampere Rating	Circuit Breaker Type	Lug Wire Range *
100	FI	one #14-1/0 Cu or one #12-1/0 Al
125	ED,EG,EJ	one #14-2/0 Al/Cu
150	HD, HG, HJ, HL	one #14-3/0 Al/Cu
250	JD, JG, JJ, JL	one 3/0-350 kcmil Al/Cu
250	KI	one 1/0-350 kcmil Al/Cu
400	LA, LH	one #1-600 kcmil or two #1-250 kcmil Al/Cu
600	LC, LI, LE, LX, LXI	two 4/0-500 kcmil Al/Cu

Optional Main Lug Kits for NF Main Lug Panelboards

* The lug range shown is for the highest ampere of the circuit breaker frame shown in the table.

Amps	Aluminum				Copper			
	Aluminum Mechanical ●		Aluminum Compression		Copper Mechanical		Copper Compression	
	Cat. #	Lug Wire Range	Cat. #	Lug Wire Range	Cat. #	Lug Wire Range	Cat. #	Lug Wire Range
125	NFALM1	(1) #6-2/0	NFALV1▼	(1) #4-300 kcmil	NFCUM1	(1) #6-350 kcmil	NFCUV1■	(1) #6-1/0
250	NFALM2	(1) #6-350 kcmil	NFALV2	(1) 250-350 kcmil	NFCUM2	(1) #6-350 kcmil	NFCUV2■	(1) 2/0-300 kcmil
400	NFALM4	(1) 1/0-750 kcmil or (2) 1/0-350 kcmil	NFALV4	(2) 2/0-500 kcmil	NFCUM4	(1) 1/0-750 kcmil or (2) 1/0-350 kcmil	NFCUV4	(1) 400-750 kcmil
600	NFALM6	(2) 1/0-600 kcmil	NFALV6	(2) 2/0-500 kcmil	NFCUM6	(2) 1/0-750 kcmil	NFCUV6	(2) 250-500 kcmil
800	Factory Assembled Only – Contact Local Sales Office.							

▼ Use of this kit requires an additional 6" added to the box height. ■ Use of this kit to terminate larger than standard wire sites requires an additional 6" added to the box height.
● Standard mechanical lugs for Main Lugs panels.

NF RTI (ready to install) Accessories

Description	Application	Catalogue No.
Equipment Ground Bars	Aluminum	PK27GTA
	Copper	PK27GTACU
	Large Al Lug	PK23GTAL
	Insulator Kit	PKGTAB
Plastic stick-on directory pouch		80031 15 901
Directory Cards		80031 15 801
Filler Plate (15 per package)		NFFP15
Circuit Numbering Strips	Odd-Even 1-102	NF102OE
	Sequential 1-102	NF102S
	Odd-Even 103-204	NF204OE
	Sequential 103-204	NF204S
Rail & Deadfront extensions	6" Extension	NF6RDE
	12" Extension	NF12RDE
	18" Extension	NF18RDE
Branch Breaker Accessories		
Standard AL lugs 15-30A (3 per kit)		AL30FD
Standard AL lugs 35-110A (3 per kit)		AL100FD
Optional Cu lugs 15-110A (3 per kit)		CU100FD
Handle lockoff/padlock attachment		HPAFD
Terminal nut insert kit (3 per kit)		TIKFD
AL compression lug kit #8-1/0 AWG (3 lugs per kit)		VC100FD
Cu compression lug kit #6-1/0 AWG (3 lugs per kit)		CVC100FD

Description	Application	Catalogue No.
Lock - Enclosures	Type 1	PK22FL
Key - NSR-251	Type 1 encl.	LP 9618
Key - DSR-251	Type 3R encl.	DSR251
Handle Padlock Attachment	Breakers	HPAFD
Mounting Nut (4 per pkg.)	Interiors	23220 000 03
Leveling Nut (4 per pkg.)	Flush only	NFLN

Trim Mounting Screws & Hardware

250A Max. Interiors (10 per pkg.)		NFTMS1
800A Max Interiors (8 per pkg.)		LP9502
Drip Hood for std encl.	20" Wide	MHT2DH20
Aluminum Entry Plate		MHCOEW20A
Fibre Entry Plate		MHCOEW20F
Barrier for Backed Main Breaker	20" Enclosure ●	NFBFMB20
Nipple Kit for Flush Mount Trims		DTNKF
Nipple Kit for Surface Mount Trims		DTNKS

Note:
● In back-fed main breaker application the use of NFBFMB20 barrier is recommended. Please refer to local Electrical Codes or Authorities for specific local requirements.

Oversized Lugs for Neutral or Ground Bar

Lug Wire Range	Catalogue No.
#10-#2 Al or #14-#4 Cu	QO70AN
#4-#1/0 Al/Cu	Q1100AN
#1-#4/0 Al/Cu	Q1150AN



200% Neutral Kit



Ground bar PK27GTA



Stainless Steel Type 4x Enclosure

Single Row - (Column-Width) NQ/NF Panelboards – Ready To Install (RTI)

240 Vac and 600Y/347 Vac

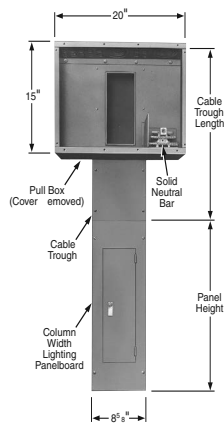

NQ Single Row—240 Vac Bolt-On

NQ Application Data

Application: For use on ac only. Meet Federal Specification W-P-115c, Type 1, Class 1.

Service: 1Ø3W, 3Ø3W, 3Ø4W, 3 Grd. "B" Ø —240 Vac max.

Mains: Bolt-on main lugs: 100 A

225 A main circuit breaker: 100 A—QOU, 225 A—QB. See pages DE3-12 for main circuit breaker interrupting rating.

Branches: Bolt-on QOB, 60 A maximum. QOB 10-60 A 1-, 2- and 3-pole. See page DE5-4 for branch circuit breaker terminal data.

Cabinet: Front—Screw cover. Box—galvanized steel with removable endwalls.

Gutters: 100 A—4" Min. mains end, 3" Min. opposite mains; 225 A—10" Min. mains end, 5" Min. opposite mains.

NQ Single Row—240 Vac Bolt-On

60 A Maximum Branch—Copper Bus Standard

Max. No. of Poles	Mains Rating	Box and Interior with S/N 8.625" W. x 5" D.		Front (Surface Mount) Catalogue Number
		Catalogue Number	Box Ht.	
1 Phase 3-Wire Main Lugs Only				
30	225	NQ830L2C	45	LX45TS
Main Circuit Breaker—2-pole				
20	100	NQ820B1C	40	LX40TS
3 Phase 4-Wire Main Lugs Only				
30	100	NQ8430L1C	40	LX40TS
42	225	NQ8442L2C	58	LX58TS
Main Circuit Breaker—3-pole				
30	100	NQ8430B1C	45	LX45TS
42	225	NQ8442B2C	62	LX62TS

NQ Single Row

Cable Troughs and Pull Boxes

L (IN)	Cable Troughs (L=Length) [▲]		Pull Boxes with Solid Neutral	
	8.625" x 5" Catalogue Number	S/N Terminals	S/N Terminals	Catalogue Number
36	MTX836	42	MPX81542	
48	MTX848			
56	MTX856			
66	MTX866			

[▲] Cable troughs are standard with a trough barrier.

NF Single Row—600Y/347 Vac 3Ø4W (60 A Max. Branch Circuit Breaker)

NF Application Data

Application: For use on ac only. Meet Federal Specification W-P-115c, Type 1, Class 1. cULus Listed.

Service: 600Y/347 Vac, 3Ø4W

Mains: Bolt-on main lugs: 125 A, 225 A

Main circuit breaker: 100 A - FA, 100A-HD, 225 A - JD. See pages DE3-12, 13 & 17 for main circuit breaker ratings. See catalogue section for terminal lug data.

Main circuit breakers with higher interrupting ratings are available as factory assembled panelboards in the following configurations:

Mains Rating	Circuit Breaker	Max. No. of Poles
100A	FH, HD, HG, HJ, HL (100A max)	30
	FI	42
225A	HD, HG, HJ, HL (150A max)	42
	KI, JD, JG, JJ, JL (225A max)	

Branches: EDB, EDG or EDJ, 60 A maximum. See pages DE5-11 for branch circuit breaker terminal data.

Cabinet: Front - Screw cover. Box - galvanized steel with removable endwalls.

Gutters: 100 A - 4" Min. mains end, 3" Min. opposite mains; 225 A - 10" Min. mains end, 5" Min. opposite mains.

Bussing: Copper bus standard.

NF Single Row—600Y/347 Vac 3Ø4W

60 A Max. Branch Circuit Breaker

Max. No. of Poles	Mains Rating	Box and Interior with S/N 8.625" W. x 5.625" D.		Front (Surface Mount) Catalogue Number	
		Catalogue Number	Box Ht.		
Main Lugs Only—3 Phase 4-Wire					
30	125	NF8430L1C	59	NC59TS	
42	225	NF8442L2C	71	NC71TS	
Main Circuit Breaker—3-pole /3phase-4 wire					
Number of Circuits	Maximum Main Circuit Breaker Ampere Rating	3 Phase, 4-Wire catalog No.		H	
		Interior	Trim Front	in.	mm
30	100 A ■	NF8430M1C	NC65TS	65	1651
30	100 A ▲	NF8430M1HDC	NC65TS	65	1651
42	225 A ▼	NF8442M2JDC	NC85TS	85	2159

■ Uses 100A FA type main breaker.
▲ Uses 100A HD type main breaker.
▼ Uses 225A JD type main breaker.

NF Single Row

Cable Troughs and Pull Boxes

L (IN)	Cable Troughs (L=Length) [▲]		Pull Boxes with Solid Neutral	
	8.625" x 5.625" Catalogue Number■	S/N Terminals	S/N Terminals	Catalogue Number
36	NTX836	42	MPX81542	
48	NTX848			
56	NTX856			
66	NTX866			

[▲] Cable troughs are standard with a trough barrier.
[■] Box width=8.625, width at front, including flange, is 9.625

Factory assembled NQ/NF single row panels are available. Contact your nearest Schneider Electric sales office.

DE5 PANELBOARDS

Panelboards

I-Line® - 600 Vac, 250 Vdc – Ready to Install (RTI)

HCM Main Lugs Only (Can be equipped with branch mounted backfed Main Circuit Breaker)

Mains Ampere Rating	Total branch breaker mounting space (in)	Interior Assembly ⁺	Trim ^{◆ ▲}		Enclosure ^{※ ●}		Box Height (in)
			4 Piece No Door [■]	With Door	Type 1	Type 3R/12* (Includes trim)	
225	27	HCM14482N	HCM48T()	HCM48T()D	HC3248B	HC3248WP	48
400		HCM14484					
600		HCM14486					
800		HCM14488					
225	45	HCM23642N	HCM64T()	HCM64T()D	HC3264B	HC3264WP	64
400		HCM23644					
600		HCM23646					
800		HCM23648					
225	63	HCM32732N	HCM73T()	HCM73T()D	HC3273B	HC3273WP	73
400		HCM32734					
600		HCM32736					
800		HCM32738					
225	99	HCM50912N	HCM91T()	HCM91T()D	HC3291B	HC3291WP	91
400		HCM50914					
600		HCM50916					
800		HCM50918					

TYPE HCM

250 A max. branch circuit breaker
FA, FH, QB, QD, QG, QJ, HD, HG,
HJ, HL, HR, JD, JG, JJ, JL, JR

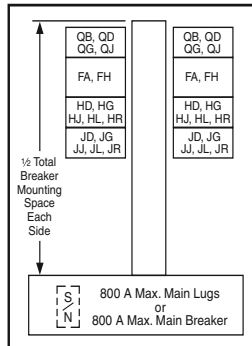

Box Size: 32" Wide,
8.25" & 9.5" Deep

HCM Main Circuit Breaker (Includes 3 pole, vertically mounted Main Circuit Breaker)

Mains Ampere Rating	Total branch breaker mounting space (in)	Interior Assembly ⁺	Trim ^{◆ ▲}		Enclosure ^{※ ●}		Box Height (in)
			4 Piece No Door [■]	With Door	Type 1	Type 3R/12* (Includes trim)	
400	27	HCM14644M	HCM64T()	HCM64T()D	HC3264B	HC3264WP	64
225		HCM18642MN					
600	36	HCM18736MP	HCM73T()	HCM73T()D	HC3273DB9	Not available use HCP	73
800		HCM18738MP					
400	45	HCM23734M	HCM91T()	HCM91T()D	HC3273B	HC3273WP	91
225	54	HCM27732MN					
600	72	HCM36916MP	HCM91T()	HCM91T()D	HC3291DB9	Not available use HCP	91
800		HCM36918MP					
400	81	HCM41914M			HC3291B	HC3291WP	

HCP-SU Universal Panelboard-Main Lugs or Backfed Main Circuit Breaker

Mains Ampere Rating	Total branch breaker mounting space (in)	Interior Assembly ⁺	Trim ^{◆ ▲}		Enclosure ^{※ ●}		Box Height (in)
			4 Piece No Door	With Door	Type 1	Type 3R/12* (Includes trim)	
800	54	HCP54868SU	HC2686T()4P	HC2686T()HR	HC2686DB	HC2886WP	86

TYPE HCP-SU

800 A max. backfed main circuit breaker
600 A max. branch circuit breaker
FA, FH, LA, LH, LD, LG, LJ, LL, LR, MG, MJ, PG, PJ, PL, PGC, PJC, PLC*, QB, QD, QG, QJ, HD, HG, HJ, HL, HR, JD, JG, JJ, JL, JR

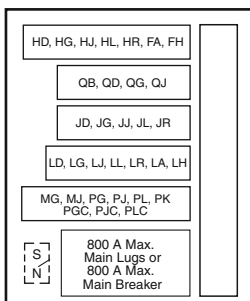

Box Size: 26" Wide, 9.5" Deep

- ※ **Tubs** - Unpainted, galvanized steel without knockouts.
- ◆ **Trims** - Grey baked enamel finish 4 piece trim and lockable door kit.
- ▲ Add "F" for Flush or "S" for Surface.
- Add-on door kit available. Example: For HCM48TS surface trim kit, order HCM48DS door kit.
- For Type 1 applications, order interior, trim, and enclosure. For Type 3R/5/12 applications, order interior and enclosure only. The trim is included with the box.
- ★ Remove drain screws for Type 3R rating.
- ▼ Bottom feed standard.
- For main lugs panel, order sub-feed lug kit and back-feed as main lugs.
- ☆ PG, PJ, PL circuit breakers are available with both thermal-magnetic equivalent and MICROLOGIC trip. The MICROLOGIC circuit breakers are available 80% and 100% rated. "C" suffix denotes a 100% rating.
- ▽ For circuit breaker interrupting ratings, see pages 5-24 through 5-30.
- ✦ Interior complete with Solid Neutral when part number has "N" suffix. 100A and 225A interiors include solid neutral, all others without solid neutral. Order solid neutral from page 5-21.
- ☑ In Backfed Main Breaker applications, the use of backfed barriers from page 5-23 may be required and is strongly recommended. Refer to local Electrical Codes or Authorities for specific requirements.

DE5 PANELBOARDS

Panelboards

I-Line® – 600 Vac, 250 Vdc - Ready to Install (RTI)

TYPE HCP (Main Lugs Only)

800 A max. branch circuit breaker
 FA □, FH, QB, OD, QG, QJ, LA, LH, LD, LG, LJ, LL, LR, PG, PJ, PL, PGC, PJC, PLC ◇, MG, MJ, HD, HG, HJ, HL, HR, JD, JG, JJ, JL, JR

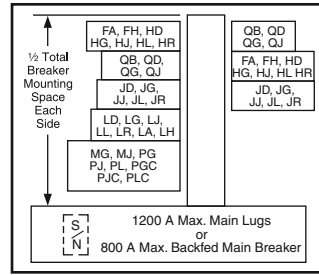

Box Size: 42" Wide, 9.5" Deep

HCP Main Lugs Only (Can be equipped with branch mounted backfed Main Circuit Breaker) ▣

Mains Ampere Rating	Mounting Inches	Max # of PL Breakers on left side	Interior Assembly ✦	Trim ◆ ▲		Enclosure ✧ ●		Box Height (in)
				4 Piece No Door ■	With Door	Type 1	Type ○ 3R/12	
400	27	1 PL	HCP14504	HCW50T()	HCW50T()D	HC4250DB	HC4250WP	50
600			HCP14506					
800			HCP14508					
1200			HCP145012N					
400	45	2 PL	HCP23594	HCW59T()	HCW59T()D	HC4259DB	HC4259WP	59
600			HCP23596					
800			HCP23598					
1200			HCP235912N					
400	63	3 PL	HCP32684	HCW68T()	HCW68T()D	HC4268DB	HC4268WP	68
600			HCP32686					
800			HCP32688					
1200			HCP326812N					
400	99	5 PL	HCP50864	HCW86T()	HCW86T()D	HC4286DB	HC4286WP	86
600			HCP50866					
800			HCP50868					
1200			HCP508612N					

HCP Main Circuit Breaker ▽ (Includes 3 pole, vertically mounted Main Circuit Breaker)

Mains Ampere Rating	Mounting Inches	Max # of LC Breakers on left side	Interior Assembly ✦	Trim ◆ ▲		Enclosure ✧ ●		Box Height (in)
				4 Piece No Door ■	With Door	Type 1	Type ○ 3R/12	
600	36	2 LC	HCP18686M	HCW68T()	HCW68T()D	HC4268DB	HC4268WP	68
800			HCP18688M					
600	72	4 LC	HCP36866M	HCW86T()	HCW86T()D	HC4286DB	HC4286WP	86
800			HCP36868M					

- * **Tubs** - Unpainted, galvanized steel without knockouts.
- ◆ **Trims** - Grey baked enamel finish 4 piece trim and lockable door kit
- ▲ Add "F" for Flush or "S" for Surface.
- Add-on door kit available. Example: For HCW50TS trim kit, order HCW50D door kit.
- ◆ See page 5-21 for 42" wide weatherproof enclosures.
- ☆ 15" of mounting space is taken up by the back fed main lug kit or RG, RJ, RL main circuit breaker, leaving 93" of branch circuit breaker mounting space.
- FA and JDA circuit breakers with field installable ground fault kits may be mounted in type HCP, HCP-SU, HCW and HCR-U panelboards as shown, and require L-frame mounting space.
- ◇ PG, PJ, PL circuit breakers are available with both thermal-magnetic equivalent and MICROLOGIC trip. The MICROLOGIC circuit breakers are available 80% and 100% rated. "C" suffix denotes a 100% rating.
- ✦ Interior complete with Solid Neutral when part number has "N" suffix. 100A and 225A interiors include solid neutral, all others without solid neutral. Order solid neutral from page 5-21.
- Remove drain screws for Type 3R rating.
- ▣ In Backfed Main Breaker applications, the use of backfed barriers from page 5-23 may be required and is strongly recommended. Refer to local Electrical Codes or Authorities for specific requirements.
- For Type 1 applications, order interior, trim, and enclosure. For Type 3R/5/12 applications, order interior and enclosure only. The trim is included with the box.
- HCP available with 200% rated neutral, 600A, MLO, MB, as factory assembled only.

DE5 PANELBOARDS

Panelboards

I-Line® - 600 Vac, 250 Vdc – Ready to Install (RTI)

TYPE HCR-U Universal Mains
 1200 A max. branch circuit breaker
 FA, FH, QB, QD, QG, QJ, HD, HG, HJ, HL, HR, JD, JG, JJ, JL, JR, LA, LD, LG, LJ, LL, LR, MG, MJ, PG, PJ, PL, PGC, PJC, PCL, RGC, RJC, RLC

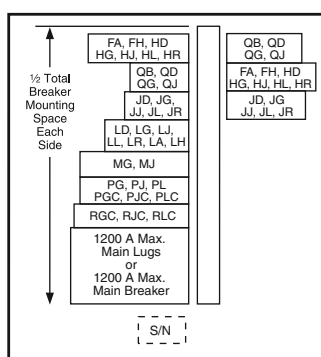

Box Size: 44" Wide, 9.5" Deep

HCR-U Universal Main Lugs Only (Can be equipped with branch mounted backfed Main Circuit Breaker)▼
 MAIN LUGS panel, order sub-feed lug kit catalogue number S33930 and back feed as main lugs.
 MAIN CIRCUIT BREAKER panel, order plug-on I-LINE type PG, PJ, PL, RGC, RJC or RLC circuit breakers from page 5-30: back-fed as the main circuit breaker (Order solid neutral separately). The use of backfed MB barriers from page 5-21 is strongly recommended. Please refer to local Electrical Codes or Authorities for specific local requirements.

Mains Ampere Rating	Mounting Inches ☆	Max # of PL, RL Breakers on left side	Interior Assembly ‡	Trim ◆ ▲		Enclosure ※ ●		Box Height (in)
				4 Piece No Door ■	With Door	Type 1	Type ○ 3R/12	
1200	108	6 PL or 3 RLC	HCR548612U	HCR86T()	HCR86T()D	HC4486DB	HC4486WP	86

Note: 1. Subfed kit # S33931 or back fed P-frame main breaker require 9" mounting space – branch space reduced to 99".
 2. Subfed kit # S33930 or back fed R-frame main breaker require 15" mounting space – branch space reduced to 93".
 3. 1200A HCR-U interior – copper bus standard

Main Circuit Breaker Interiors— Standard Frame Types

Main Circuit Breaker Ampacity	Panelboard Type	Factory Supplied Main Circuit Breaker
225	HCM	JDA36225
400	HCM	LA36400
600 or 800	HCM, HCP	MGP36600 or MGP36800

Standard Copper Bus Interiors △

Type	Main Ampacity
HCM, HCP-SU	800
HCP, HCR-U	800 & Above

Note:

Merchandised copper interiors are not available in all ampacities.

- ※ **Tubs** - Unpainted, galvanized steel without knockouts.
- ◆ **Trims** - Grey baked enamel finish 4 piece trim and lockable door kit.
- ▲ Add "F" for Flush or "S" for Surface.
- Add-on door kit available. Example: For HCW50TS trim kit, order HCW50D door kit.
- ◆ See page 5-22 for 42" wide weatherproof enclosures.
- ▼ When RL main circuit breakers with equipment ground fault are applied on a 3Ø4W system, order solid neutral catalogue number HCR12SNCT. The HCR12SNCT includes a neutral current transformer.
- FA circuit breakers with field installable ground fault kits may be mounted in type HCP, HCP-SU, HCW, HCWM and HCR-U panelboards as shown, and require L-frame mounting space.
- ◇ PG, PJ, PL circuit breakers are available with both thermal-magnetic equivalent and MICROLOGIC trip. The MICROLOGIC circuit breakers are available 80% and 100% rated. "C" suffix denotes a 100% rating.
- ‡ Interior complete with Solid Neutral when part number has "N" suffix. 100A and 225A interiors include solid neutral, all others without solid neutral. Order solid neutral from page 5-21.
- Remove drain screws for Type 3R rating.
- For Type 1 applications, order interior, trim, and enclosure. For Type 3R/5/12 applications, order interior and enclosure only. The trim is included with the box.
- HCR-U with 200% neutral – factory assembled only.

Circuit Breaker / Sub-Feed Lug Kit Mounting Inch Requirement

Type of Circuit Breaker	Maximum Ampacity	No. of Poles	Mounting Requirement	Type of Circuit Breaker	Maximum Ampacity	No. of Poles	Mounting Requirement
FY, FG, FJ	30 A	1	1.5"	JD, JG, JJ, JL, JR, SL250	250 A	2, 3	4.5"
FA, FH	100 A	1	1.5"	LA, LH, SL400	400 A	2, 3	6"
FA, FH	100 A	2	3"	LC, LI, LX, LXI, LE	600 A	2, 3	7.5"
FA, FH, FI, SL-100	100 A	2, 3	4.5"	LD, LG, LJ, LL, LR	600 A	3	6"
HD, HG	150 A	2	3"	MA, MH, MG, MJ, SL800	800 A	2, 3	9"
HD, HG, HJ, HL, HR	150 A	2, 3	4.5"	PG, PJ, PL, PK, S33931	1200 A	2, 3	9"
QB, QD, QG, QJ	225 A	2	3"	RG, RJ, RL, RK, S33930	1200 A	2, 3	15"
QB, QD, QG, QJ	225 A	3	4.5"				

DE5 PANELBOARDS

Panelboards

I-Line® – Ready to Install (RTI)



Blank Fillers



Solid Neutral



Blank Extensions



Equipment Ground Bar

I-Line Merchandised Panelboard Accessories

Description	Catalogue No.
Blank Fillers—1.5 in. (minimum order 3) ▼	HNM1BL
Blank Fillers—4.5 in. (minimum order 5) ▼	HNM4BL
Solid Neutral Assemblies	
225 A	HC2SN
400 A	HC4SN▲, HCW4SN■
600 A	HC6SN▲, HCW6SN■
	HC8SN▲, HCW8SN■
800 A	HCPSU8SN◆
	HCPSU8SNCT◆
1200 A	HCW12SN■
1200 A, for use with HCR-U universal panel only	HCWM12SN★
1200 A, including neutral CT for 3Ø4W systems	HCR12SNCT★
HCM, HCP, HCR-U	PK32DGTA
Blank Extensions (For replacement purposes)	
1.5 in. for mounting on wide side of I-Line panelboard (minimum order 3) ▼	HLW1BL
4.5 in. for mounting on wide side of I-Line panelboard (minimum order 5) ▼	HLW4BL
1.5 in. for mounting on narrow side of I-Line panelboard (minimum order 3) ▼	HLN1BL
4.5 in. for mounting on narrow side of I-Line panelboard (minimum order 5) ▼	HLN4BL
4.5 in. for mounting on wide side of I-Line panelboard (minimum order 5) ▼	HLW4EBL
4.5 in. for mounting on narrow side of I-Line panelboard (minimum order 5) ▼	HLN4EBL

- ▲ Used on Type HCM.
- Used on 400 A, 600 A, 800 A, and 1200 A HCP (main lugs), and 600 A and 800 A (main circuit breaker).
- ◆ Used on Type HCP-SU.
- ★ Used on Type HCR-U.
- ▼ Blank extension pricing is per unit. Multiply the list price by the quantity ordered. Note minimum order quantity.

Crimp Lug Adapter Kits

	Panelboard Type	Panelboard Type	
		HCM	HCP, HCR-U *
(For use with MLO panels, order VCEL lugs separately)	400A	HCM400VCA	HCW400VCA
	600A	HCM600VCA	HCW600VCA
	800A	HCM800VCA	HCW800VCA
	1200A	- - -	HCW1200VCA

* HCR-U - order P or R frame circuit breaker lug kit.

Type 3R/12 Enclosures (includes trim)

Catalogue Number	Interior Type	Dimensions (inches)		
		H	W	D
HC4250WP	HCP	50	42	12.95
HC4259WP	HCP	59	42	12.95
HC4268WP	HCP	68	42	12.95
HC4286WP	HCP	86	42	12.95
HC4486WP	HCR-U	86	44	14.50

Box Extensions - Type 1

Catalogue Number	Interior Type	Extension
HC2609DEX (F or S)	HCP-SU	9"
HC3209DEX (F or S)	HCM	9"
HC4212DEX (F or S)	HCP	12"
HC4406DEX (F or S)	HCR-U	6"
HC4412DEX (F or S)	HCR-U	12"



Box Extension



I-Line Plug-On Unit with Surgellogic SPD

Surgellogic™ SPD

Surgellogic SPD unit in I-Line plug-on construction: An integrally mounted surge protection solution that mounts on to an I-Line Panelboard bus stack just like any I-Line circuit breaker. Requires 13.5 in. of mounting height. Available as factory assembled and merchandised. For SPD unit information, refer to SPD section.

Panelboards I-Line® – Ready to Install (RTI)



Sub-feed Lug Kits

Sub-Feed Lug Kits★, also used for Feed Through Lugs (Plug-on in same manner as a branch circuit breaker)

Ampere Rating	Height		Catalogue Number	Max. Short Circuit System Ratings RMS Symmetrical Amperes			Protected by Circuit Breaker	For use in Panelboard Types
	In	mm		240 Vac	480 Vac	600 Vac		
100 A	4.5	114	SL100	100 K	65 K	18 K	FA, FH, FD, FG, FJ	HCM, HCP, HCP-SU, HCR-U
250 A	4.5	114	SL250	200 K	200 K	100 K	FA, FD, FG, FH, FJ, HD, HG, HJ, HL, HR, JD, JG, JJ, JL, JR, KI	HCM, HCP, HCP-SU, HCR-U
400 A	6	152	SL400 △	200 K	200 K	100 K	FA, FD, FG, FH, FJ, KA, KH, KC, KI, HD, HG, HJ, HL, HR, JD, JG, JJ, JL, JR, LA, LH, LC, LX, LI, LXI, DG, DJ, DL, LD, LG, LJ, LL, LR ("L" & "D" FRAME 400A MAX.)	HCP, HCP-SU, HCR-U (wide side only)
800 A	9	229	SL800	200 k	100 k	50 k	FA, FD, FG, FH, FJ, KA, KH, KC, KI, HD, HG, HJ, HL, HR, JD, JG, JJ, JL, JR, LA, LH, LC, LX, LI, LXI, MA, MH, MX, DG, DJ, DL, LD, LG, LJ, LL, LR	HCM, HCP, HCP-SU, HCR-U
800 A	9	229	SL800M5	125 K	100 K	25 K	FA, FD, FG, FH, FJ, KA, KH, KC, KI, HD, HG, HJ, HL, HR, JD, JG, JJ, JL, JR, MA, MH, MX, MG, PG, MJ, PJ, PK, PL, DG, DJ, DL, LD, LG, LJ, LL, LR	HCM, HCP, HCP-SU, HCR-U
1200	9	229	S33931	125 K	100 K	50 K	FA, FD, FG, FH, FJ, KA, KH, KC, KI, HD, HG, HJ, HL, HR, JD, JG, JJ, JL, JR, LA, LH, LC, LX, LI, LXI, MA, MH, MX, MG, PG, MJ, PJ, PK, PL, DG, DJ, DL, LD, LG, LJ, LL, LR	HCP, HCP-SU, HCR-U
1200	15	381	S33930	125 K	100 K	50 K	FA, FD, FG, FH, FJ, KA, KH, KC, KI, HD, HG, HJ, HL, HR, JD, JG, JJ, JL, JR, LA, LH, LC, LX, LI, LXI, MA, MH, MX, NA, NC, NX, MG, PG, MJ, PJ, PK, PL, RG, RJ, RL, RK, DG, DJ, DL, LD, LG, LJ, LL, LR	HCR-U
1200	9	229	SL1200P5 SL1200P6 SL1200P7	125 K	100 K	50 K	FA, FD, FG, FH, FJ, KA, KH, KC, KI, HD, HG, HJ, HL, HR, JD, JG, JJ, JL, JR, MG, PG, MJ, PJ, PK, PL, RG, RJ, RL, RK, DG, DJ, DL, LD, LG, LJ, LL, LR	HCP, HCP-SU, HCR-U

NOTE: S33930, S33931, SL1200P5, SL1200P6, SL1200P7, SL Kits are rated 1200A and may be applied to 1200 ampere loads when installed into HCRU panelboards. However, when installed into HCP and HCPSU panelboards they are only rated 800 amperes maximum due to restricted wire bending space.

★ For other ratings, see the latest edition of I-Line Information Manual #80043-309-xx
 △ SL400 cannot be used in HCM panelboards due to inadequate wire bending space.

Sub-feed lug kit terminal data

Catalogue Number	Poles	Ampere Rating	Std. Lug Kit Cat #	Standard Lug Wire Size □
SL100	3	100	AL100FA	#14 - 1/0 AWG Cu or #12-1/0 AWG Al
SL250	3	250	- - -	#4 AWG - 300 kcmil
SL400	3	400	AL400LA	(1) #1 AWG - 600 kcmil or (2) #1 AWG - 250 kcmil
SL800	3	800	AL900MA	(3) #3/0 AWG - 500 kcmil
SL800M5	3	800	AL800M23K	(3) 3/0 AWG - 500 kcmil
S33931	3	1200	AL1200P24K	(4) #3/0 AWG - 500 kcmil
S33930	3	1200	AL1200R53K	(4) #3/0 AWG - 600 kcmil
SL1200P5	3	1200	AL1200P25KU	(4) 3/0 AWG - 500 kcmil
SL1200P6	3	1200	AL1200P6KU	(3) 350-600 kcmil
SL1200P7	3	1200	AL1200P7KU	(3) 3/0 AWG - 750 kcmil (750 kcmil; compact AL only)

□ Unless otherwise specified, wire sizes apply to both aluminum and copper conductors.

DE5 PANELBOARDS

Panelboards

I-Line® – Ready to Install (RTI)

Terminal Data

Standard Mechanical Lugs—Main Lugs

Panel Type	Ampere Rating	Lug Wire Range■	Wire Range Wire Bending Space per CSA
I-LINE	100
	225	(1) #6–300 kcmil Al/Cu	(1) #6–300 kcmil Al/Cu
	400	(2) #2–600 kcmil Al/Cu	(1) #2–600 kcmil Al/Cu (2) #2–500 kcmil Al/Cu
	600	(2) #2–600 kcmil Al/Cu	(2) #2–500 kcmil Al/Cu
	800	(4) 3/0–750 kcmil Al/Cu	(3) 3/0–500 kcmil Al/Cu
	1200	(4) 3/0–750 kcmil Al/Cu	(4) 3/0–500 kcmil Al/Cu

Standard Mechanical Lugs—Main Circuit Breaker

Panel Type	Ampere Rating	Circuit Breaker Type	Lug Wire Range	Wire Range Wire Bending Space per CSA
I-LINE	100	FA, FH, FI	(1) #14–1/0 Al/Cu	(1) #14–1/0 Al/Cu
	150	HD, HG, HJ, HL, HR	(1) #14–3/0 Al/Cu	(1) #14–3/0 Al/Cu
	225	KI	(1) #4–300 kcmil Al/Cu	(1) #4–300 kcmil Al/Cu
	250	JD, JG, JJ, JL, JR	(1) 4–4/0 Al/Cu (175A), 3/0–350 kcmil Al/Cu (250A)	(1) 1/0–300 kcmil Al/Cu
	250	LXI	(2) #1–350 kcmil Al/Cu	(2) #1–350 kcmil Al/Cu
	400	LA, LH	(1) #1–600 kcmil Al/Cu (2) #1–250 kcmil Al/Cu	(1) #1–600 kcmil Al/Cu (2) #1–250 kcmil Al/Cu
	600	LC, LX, LE, LI, LXI	(2) 4/0–500 kcmil Al/Cu	(2) 4/0–500 kcmil Al/Cu
	800	MG, MJ, PG, PJ, PK	(3) 3/0–500 kcmil Al/Cu	(3) 3/0–500 kcmil Al/Cu
	1200	PG, PJ, PL, PK, RG, RJ, RL, RK	(4) 3/0–500 kcmil Al/Cu	(4) 3/0–500 kcmil Al/Cu

Backfed Main Breaker kits

To be used in Canada only, to utilize a branch breaker in the I-Line panel as a Main Breaker by back feeding it. The use and correct application of these kits and attached labels are mandatory in such applications.

Backfed Main breaker kits part numbers	Branch breakers to be used with
FITC & HCBFMBL	FI
FAHCTC & HCBFMBL	FA, FH, FC
HDTTC & HCBFMBL	HD, HG, HJ, HL
QTC & HCBFMBL	QD, QG, QJ
KAHCITC & HCBFMBL	KA, KH, KC, KI
JDTC & HCBFMBL	JD, JG, JJ, JL
LAHTC & HCBFMBL	LA, LH
LCIXETC & HCBFMBL	LC, LI, LX, LE
MGJTC & HCBFMBL	MG, MJ
PA8TC & HCBFMBL	PG, PJ, PL, PK (800A max bkrs)
PA12TC & HCBFMBL	PG, PJ, PL, PK (1200A max bkrs)
RA12TC & HCBFMBL	RG, RJ, RK, RL (1200A max bkrs)

DE5 PANELBOARDS

Panelboards

I-Line® – F-Frame Circuit Breakers

QO™ Distribution Panel—240 Vac Max. Only Mounts in Type HCM, HCP, HCP-SU, or HCR-U I-Line panelboards, 30 A max. branch circuit breaker. Order QO plug-on circuit breakers from section DE3.

Maximum No. 1-pole QO Circuit Breakers	Phase Connection	Mounting Height		2-pole Catalogue Number	3-pole Catalogue Number	Price ▲
		In.	mm			
6	AB	4.5	114	HQO206AB	—	
6	BC	4.5	114	HQO206BC	—	
6	AC	4.5	114	HQO206AC	—	
6	ABC	4.5	114	—	HQO306	

▲ Includes (5) QO1DB dummy circuit breakers.

CSA Listed Interrupting Rating Amperes

Breaker Catalogue No. Prefix	System Voltage AC		
	120Vac	277Vac	347Vac
FG	65kA	35kA	18kA
FJ	100kA	65kA	25kA
FK			65kA



CSA Listed Interrupting Rating Amperes

Breaker Catalogue No. Prefix	System Voltage AC			DC	
	120/240	277/480	347/600	125	250
FA (240V)					
1-Pole	10k			5k	
2, 3-Pole	10k			5k	5k†
FA (480V)					
1-Pole	25k	18k		10k	
2, 3-Pole	25k	18k		10k	10k†
FA (600V)					
1-Pole	25k	18k	14k	10k	
2, 3-Pole	25k	18k	14k	10k	10k†
FH					
1-Pole					
15-30	65k	65k	18k	10k	
35-100	65k	25k	18k	10k	
2, 3-Pole	65k	25k	18k	10k	10k

† 125Vdc

★ Example: 30A, 480 volt breakers as shown.

Phase Connection	System Voltage AC		
	1-Pole	2-Pole	3-Pole
A	FA14030A		
B	FA14030B		
C	FA14030C		
AB		FA24030AB	
AC		FA24030AC	
BC		FA24030BC	
ABC			FA34030
CBA			FA34030CBA

For bolt-on, add letter B to Catalogue number. Example: FAB17015.

I-LINE Circuit Breakers

30 Ampere Frame

Ampere Rating	AC Magnetic Trip Settings Amperes	G - Interrupting Rating	J - Interrupting Rating	K - Interrupting Rating
---------------	-----------------------------------	-------------------------	-------------------------	-------------------------

FG, FJ, FK - 15A-30A, Thermal-magnetic (347V)

Ampere Rating	Hold	Trip	FG	1-Pole, 347 Vac	
				FJ	FK
15	250	500	FGA16015(*)	FJA16015(*)	FKA16015(*)
20	250	500	FGA16020(*)	FJA16020(*)	FKA16020(*)
25	250	500	FGA16025(*)	FJA16025(*)	FKA16025(*)
30	250	500	FGA16030(*)	FJA16030(*)	FKA16030(*)

* 1-Pole FG, FJ, and FK Catalogue Numbers are completed by adding the required phase connection number as a suffix to the circuit breaker.

A = 1
B = 3
C = 5

Ampere Rating	AC Magnetic Trip Settings Amperes	One Pole★		Two Pole★		Three Pole		Standard Lug Kit Wire Range
		Catalogue No.	Price	Catalogue No.	Price	Catalogue No.	Price	

100 Ampere Frame

FA Standard Interrupting 120/240 Volt

Ampere Rating	Hold	Trip	120Vac		240Vac		Standard Lug Kit Wire Range
			Catalogue No.	Price	Catalogue No.	Price	
15	275	600	FA12015()		FA22015()	FA32015	
20	275	600	FA12020()		FA22020()	FA32020	AL50FA
25	275	600	FA12025()		FA22025()	FA32025	1-#14-#4 Cu or
30	275	600	FA12030()		FA22030()	FA32030	1-#12-#4 Al
35	400	850	FA12035()		FA22035()	FA32035	
40	400	850	FA12040()		FA22040()	FA32040	
45	400	850	FA12045()		FA22045()	FA32045	
50	400	850	FA12050()		FA22050()	FA32050	AL100FA or
60	800	1450	FA12060()		FA22060()	FA32060	1-#14-#1/0 Cu
70	800	1450	FA12070()		FA22070()	FA32070	1-#12-#1/0 Al
80	800	1450	FA12080()		FA22080()	FA32080	
90	900	1700	FA12090()		FA22090()	FA32090	
100	900	1700	FA12100()		FA22100()	FA32100	

FA Standard Interrupting 277/480 Volt

Ampere Rating	Hold	Trip	277Vac, 125Vdc		480Vac, 250Vdc		Standard Lug Kit Wire Range
			Catalogue No.	Price	Catalogue No.	Price	
15	275	600	FA14015()		FA24015()	FA34015	
20	275	600	FA14020()		FA24020()	FA34020	AL50FA
25	275	600	FA14025()		FA24025()	FA34025	1-#14-#4 Cu or
30	275	600	FA14030()		FA24030()	FA34030	1-#12-#4 Al
35	400	850	FA14035()		FA24035()	FA34035	
40	400	850	FA14040()		FA24040()	FA34040	
45	400	850	FA14045()		FA24045()	FA34045	
50	400	850	FA14050()		FA24050()	FA34050	AL100FA or
60	800	1450	FA14060()		FA24060()	FA34060	1-#14-#1/0 Cu
70	800	1450	FA14070()		FA24070()	FA34070	1-#12-#1/0 Al
80	800	1450	FA14080()		FA24080()	FA34080	
90	900	1700	FA14090()		FA24090()	FA34090	
100	900	1700	FA14100()		FA24100()	FA34100	

FA Standard Interrupting 347/600 Volt

Ampere Rating	Hold	Trip	347Vac, 125Vdc		600Vac, 250Vdc		Standard Lug Kit Wire Range
			Catalogue No.	Price	Catalogue No.	Price	
15	275	600	FA17015()		FA26015()	FA36015	
20	275	600	FA17020()		FA26020()	FA36020	AL50FA
25	275	600	FA17025()		FA26025()	FA36025	1-#14-#4 Cu or
30	275	600	FA17030()		FA26030()	FA36030	1-#12-#4 Al
35	400	850	FA17035()		FA26035()	FA36035	
40	400	850	FA17040()		FA26040()	FA36040	
45	400	850	FA17045()		FA26045()	FA36045	
50	400	850	FA17050()		FA26050()	FA36050	AL100FA
60	800	1450	FA17060()		FA26060()	FA36060	1-#14-#1/0 Cu or
70	800	1450	FA17070()		FA26070()	FA36070	1-#12-#1/0 Al
80	800	1450	FA17080()		FA26080()	FA36080	
90	900	1700	FA17090()		FA26090()	FA36090	
100	900	1700	FA17100()		FA26100()	FA36100	

FH High Interrupting 347/600 Volt

Ampere Rating	Hold	Trip	347Vac, 125Vdc		600Vac, 250Vdc		Standard Lug Kit Wire Range
			Catalogue No.	Price	Catalogue No.	Price	
15	275	600	FH17015()		FH26015()	FH36015	
20	275	600	FH17020()		FH26020()	FH36020	AL50FA
25	275	600	FH17025()		FH26025()	FH36025	1-#14-#4 Cu or
30	275	600	FH17030()		FH26030()	FH36030	1-#12-#4 Al
35	400	850	FH17035()		FH26035()	FH36035	
40	400	850	FH17040()		FH26040()	FH36040	
45	400	850	FH17045()		FH26045()	FH36045	
50	400	850	FH17050()		FH26050()	FH36050	AL100FA
60	800	1450	FH17060()		FH26060()	FH36060	1-#14-#1/0 Cu or
70	800	1450	FH17070()		FH26070()	FH36070	1-#12-#1/0 Al
80	800	1450	FH17080()		FH26080()	FH36080	
90	900	1700	FH17090()		FH26090()	FH36090	
100	900	1700	FH17100()		FH26100()	FH36100	

• 15-30 ampere breakers suitable for use with 60°C or 75°C conductors. 35-100 ampere breakers suitable for use with 75°C conductors.

★ 1- and 2-Pole Breaker Catalogue Numbers are completed by adding the required phase connection letters as a suffix to the circuit breakers.

Panelboards I-Line® – PowerPact Q-Frame Circuit Breakers

225 Ampere Frame

Ampere Rating AC Magnetic Trip Settings Amperes B - Interrupting D - Interrupting G - Interrupting J - Interrupting

POWERPACT™ Q-frame ■ - 225A, Thermal-magnetic (240V)

2-Pole, 240 Vac						
	Hold	Trip	10,000 AIC	25,000 AIC	65,000 AIC	100,000 AIC
70	1200	2400	QBA22070(*)	QDA22070(*)	QGA22070(*)	QJA22070(*)
80	1200	2400	QBA22080(*)	QDA22080(*)	QGA22080(*)	QJA22080(*)
90	1200	2400	QBA22090(*)	QDA22090(*)	QGA22090(*)	QJA22090(*)
100	1200	2400	QBA22100(*)	QDA22100(*)	QGA22100(*)	QJA22100(*)
110	1200	2400	QBA22110(*)	QDA22110(*)	QGA22110(*)	QJA22110(*)
125	1200	2400	QBA22125(*)	QDA22125(*)	QGA22125(*)	QJA22125(*)
150	1200	2400	QBA22150(*)	QDA22150(*)	QGA22150(*)	QJA22150(*)
175	1200	2400	QBA22175(*)	QDA22175(*)	QGA22175(*)	QJA22175(*)
200	1200	2400	QBA22200(*)	QDA22200(*)	QGA22200(*)	QJA22200(*)
225	1200	2400	QBA22225(*)	QDA22225(*)	QGA22225(*)	QJA22225(*)

3-Pole, 240 Vac						
	Hold	Trip	10,000 AIC	25,000 AIC	65,000 AIC	100,000 AIC
70	1200	2400	QBA32070(**)	QDA32070(**)	QGA32070(**)	QJA32070(**)
80	1200	2400	QBA32080(**)	QDA32080(**)	QGA32080(**)	QJA32080(**)
90	1200	2400	QBA32090(**)	QDA32090(**)	QGA32090(**)	QJA32090(**)
100	1200	2400	QBA32100(**)	QDA32100(**)	QGA32100(**)	QJA32100(**)
110	1200	2400	QBA32110(**)	QDA32110(**)	QGA32110(**)	QJA32110(**)
125	1200	2400	QBA32125(**)	QDA32125(**)	QGA32125(**)	QJA32125(**)
150	1200	2400	QBA32150(**)	QDA32150(**)	QGA32150(**)	QJA32150(**)
175	1200	2400	QBA32175(**)	QDA32175(**)	QGA32175(**)	QJA32175(**)
200	1200	2400	QBA32200(**)	QDA32200(**)	QGA32200(**)	QJA32200(**)
225	1200	2400	QBA32225(**)	QDA32225(**)	QGA32225(**)	QJA32225(**)

■ Replacement lugs are not available on QB, QD, QG, or QJ circuit breakers. Lugs for QB, QD, QG, or QJ circuit breakers accept one #4 AWG–300 kcmil. No accessories are available for PowerPact Q Frame breakers.

* 2-pole Breaker Catalogue Numbers are completed by adding the required phase connection number as a suffix to the circuit breaker.

AB=1
AC=2
BA=3
BC=4
CA=5
CB=6

** 3-pole Breaker Catalogue Numbers are completed by adding the required phase connection number as a suffix to the circuit breaker.

ABC=Standard no suffix required
CBA=6

DE5 PANELBOARDS

Panelboards

I-Line® – PowerPact H- and J-Frame Circuit Breakers



HD/HG 2-pole
3 in (76 mm)
Mounting Height



H-frame 3-pole
4.5 in (114 mm)
Mounting Height



J-frame 3-pole
4.5 in (114 mm)
Mounting Height

H-frame 150 A Thermal Magnetic CSA/UL Current-Limiting Circuit Breakers (600 Vac, 250 Vdc) with Factory Sealed Trip Units Suitable for Reverse Connection

Ampere Rating	AC Magnetic Trip Setting		D Interrupting		G Interrupting		J Interrupting ▲		L Interrupting ▲		Terminal Wire Range
	Hold	Trip	Catalogue No.		Catalogue No.		Catalogue No.		Catalogue No.		
H-Frame, 150A 2P, 600 Vac 50/60 Hz, 250 Vdc											
15	350	750	HDA26015()		HGA26015()		HJA26015()		HLA26015()		AL150HD #14-#3/0 AWG Al or Cu
20	350	750	HDA26020()		HGA26020()		HJA26020()		HLA26020()		
25	350	750	HDA26025()		HGA26025()		HJA26025()		HLA26025()		
30	350	750	HDA26030()		HGA26030()		HJA26030()		HLA26030()		
35	400	850	HDA26035()		HGA26035()		HJA26035()		HLA26035()		
40	400	850	HDA26040()		HGA26040()		HJA26040()		HLA26040()		
45	400	850	HDA26045()		HGA26045()		HJA26045()		HLA26045()		
50	400	850	HDA26050()		HGA26050()		HJA26050()		HLA26050()		
60	800	1450	HDA26060()		HGA26060()		HJA26060()		HLA26060()		
70	800	1450	HDA26070()		HGA26070()		HJA26070()		HLA26070()		
80	800	1450	HDA26080()		HGA26080()		HJA26080()		HLA26080()		
90	800	1450	HDA26090()		HGA26090()		HJA26090()		HLA26090()		
100	900	1700	HDA26100()		HGA26100()		HJA26100()		HLA26100()		
110	900	1700	HDA26110()		HGA26110()		HJA26110()		HLA26110()		
125	900	1700	HDA26125()		HGA26125()		HJA26125()		HLA26125()		
150	900	1700	HDA26150()		HGA26150()		HJA26150()		HLA26150()		

H-Frame, 150A 3P, 600 Vac 50/60 Hz, 250 Vdc

Ampere Rating	AC Magnetic Trip Setting		D Interrupting		G Interrupting		J Interrupting ▲		L Interrupting ▲		Terminal Wire Range
	Hold	Trip	Catalogue No.		Catalogue No.		Catalogue No.		Catalogue No.		
H-Frame, 150A 3P, 600 Vac 50/60 Hz, 250 Vdc											
15	350	750	HDA36015		HGA36015		HJA36015		HLA36015		AL150HD #14-#3/0 AWG Al or Cu
20	350	750	HDA36020		HGA36020		HJA36020		HLA36020		
25	350	750	HDA36025		HGA36025		HJA36025		HLA36025		
30	350	750	HDA36030		HGA36030		HJA36030		HLA36030		
35	400	850	HDA36035		HGA36035		HJA36035		HLA36035		
40	400	850	HDA36040		HGA36040		HJA36040		HLA36040		
45	400	850	HDA36045		HGA36045		HJA36045		HLA36045		
50	400	850	HDA36050		HGA36050		HJA36050		HLA36050		
60	800	1450	HDA36060		HGA36060		HJA36060		HLA36060		
70	800	1450	HDA36070		HGA36070		HJA36070		HLA36070		
80	800	1450	HDA36080		HGA36080		HJA36080		HLA36080		
90	800	1450	HDA36090		HGA36090		HJA36090		HLA36090		
100	900	1700	HDA36100		HGA36100		HJA36100		HLA36100		
110	900	1700	HDA36110		HGA36110		HJA36110		HLA36110		
125	900	1700	HDA36125		HGA36125		HJA36125		HLA36125		
150	900	1700	HDA36150		HGA36150		HJA36150		HLA36150		

J-frame 250 A Thermal Magnetic CSA/UL Current Limiting Circuit Breakers (600 Vac, 250 Vdc) with Factory Sealed Trip Units Suitable for Reverse Connection

Ampere Rating	AC Magnetic Trip Setting		D Interrupting		G Interrupting		J Interrupting ▲		L Interrupting ▲		R Interrupting ▲		Terminal Wire Range
	Hold	Trip	Catalogue No.		Catalogue No.		Catalogue No.		Catalogue No.		Catalogue No.		
J-Frame 250A 2P, 600 Vac 50/60 Hz, 250 Vdc													
150	750	1500	JDA26150()		JGA26150()		JJA26150()		JLA26150()				AL175JD #4-4/0 AWG Al or Cu
175	875	1750	JDA26175()		JGA26175()		JJA26175()		JLA26175()				AL250JD #3/0-350 kcmil Al or Cu
200	1000	2000	JDA26200()		JGA26200()		JJA26200()		JLA26200()				AL250JD #3/0-350 kcmil Al or Cu
225	1125	2250	JDA26225()		JGA26225()		JJA26225()		JLA26225()				AL250JD #3/0-350 kcmil Al or Cu
250	1250	2500	JDA26250()		JGA26250()		JJA26250()		JLA26250()				AL250JD #3/0-350 kcmil Al or Cu

J-Frame 250A 3P, 600 Vac 50/60 Hz, 250 Vdc

Ampere Rating	AC Magnetic Trip Setting		D Interrupting		G Interrupting		J Interrupting ▲		L Interrupting ▲		R Interrupting ▲		Terminal Wire Range
	Hold	Trip	Catalogue No.		Catalogue No.		Catalogue No.		Catalogue No.		Catalogue No.		
J-Frame 250A 3P, 600 Vac 50/60 Hz, 250 Vdc													
150	750	1500	JDA36150		JGA36150		JJA36150		JLA36150		JRA36150		AL175JD #4-4/0 AWG Al or Cu
175	875	1750	JDA36175		JGA36175		JJA36175		JLA36175		JRA36175		AL250JD #3/0-350 kcmil Al or Cu
200	1000	2000	JDA36200		JGA36200		JJA36200		JLA36200		JRA36200		AL250JD #3/0-350 kcmil Al or Cu
225	1125	2250	JDA36225		JGA36225		JJA36225		JLA36225		JRA36225		AL250JD #3/0-350 kcmil Al or Cu
250	1250	2500	JDA36250		JGA36250		JJA36250		JLA36250		JRA36250		AL250JD #3/0-350 kcmil Al or Cu

H-frame 150A and J-frame 250 A Electronic Trip CSA/UL Current Limiting Circuit Breakers (600 Vac) with Factory Sealed Trip Units Suitable for Reverse Connection

Electronic Trip Unit			Ampere Rating	D Interrupting		G Interrupting		J Interrupting ▲		L Interrupting ▲		R Interrupting ▲		Terminal
Type	Function	Trip Unit		Catalogue No.		Catalogue No.		Catalogue No.		Catalogue No.		Catalogue No.		
Micrologic Standard	LI	3.2◇	60	HDA36060U31X		HGA36060U31X		HJA36060U31X		HLA36060U31X		HRA36060U31X	AL150HD△	
			100	HDA36100U31X		HGA36100U31X		HJA36100U31X		HLA36100U31X		HRA36100U31X	AL250JD□	
			150	HDA36150U31X		HGA36150U31X		HJA36150U31X		HLA36150U31X		HRA36150U31X	AL250JD□	
			250	JDA36250U31X		JGA36250U31X		JJA36250U31X		JLA36250U31X		JRA36250U31X	AL250JD□	
			60	HDA36060U33X		HGA36060U33X		HJA36060U33X		HLA36060U33X		HRA36060U33X	AL150HD△	
Micrologic Ammeter	LSI	5.2A	100	HDA36100U33X		HGA36100U33X		HJA36100U33X		HLA36100U33X		HRA36100U33X	AL150HD△	
			150	HDA36150U33X		HGA36150U33X		HJA36150U33X		HLA36150U33X		HRA36150U33X	AL250JD□	
			250	JDA36250U33X		JGA36250U33X		JJA36250U33X		JLA36250U33X		JRA36250U33X	AL250JD□	
			60	HDA36060U43X		HGA36060U43X		HJA36060U43X		HLA36060U43X		HRA36060U43X	AL150HD△	
			100	HDA36100U43X		HGA36100U43X		HJA36100U43X		HLA36100U43X		HRA36100U43X	AL250JD□	
Micrologic Energy	LSI	5.2E	150	HDA36150U53X		HGA36150U53X		HJA36150U53X		HLA36150U53X		HRA36150U53X	AL150HD△	
			250	JDA36250U53X		JGA36250U53X		JJA36250U53X		JLA36250U53X		JRA36250U53X	AL250JD□	
			60	HDA36060U44X		HGA36060U44X		HJA36060U44X		HLA36060U44X		HRA36060U44X	AL150HD△	
			100	HDA36100U44X		HGA36100U44X		HJA36100U44X		HLA36100U44X		HRA36100U44X	AL250JD□	
			150	HDA36150U44X		HGA36150U44X		HJA36150U44X		HLA36150U44X		HRA36150U44X	AL250JD□	
Micrologic Energy	LSIG	6.2E	250	JDA36250U44X		JGA36250U44X		JJA36250U44X		JLA36250U44X		JRA36250U44X	AL250JD□	
			60	HDA36060U54X		HGA36060U54X		HJA36060U54X		HLA36060U54X		HRA36060U54X	AL150HD△	
			100	HDA36100U54X		HGA36100U54X		HJA36100U54X		HLA36100U54X		HRA36100U54X	AL250JD□	
			150	HDA36150U54X		HGA36150U54X		HJA36150U54X		HLA36150U54X		HRA36150U54X	AL150HD△	
			250	JDA36250U54X		JGA36250U54X		JJA36250U54X		JLA36250U54X		JRA36250U54X	AL250JD□	

▲ Circuit breakers with J, L, and R interrupting ratings are CSA/UL certified as current limiting.

△ AL150HD wire range is 14-3/0 AWG Al or Cu.

□ AL250JD wire range is 3/0 AWG-350 kcmil Al or Cu. For smaller wire range (4-4/0 AWG Al or Cu), replace the lug's wire binding screws with the larger binding screws provided.

◇ 3P circuit breakers with this trip unit can be used for 2P applications.

Panelboards

I-Line® – PowerPact J-, L-Frame Circuit Breakers

J-Frame Mission Critical Circuit Breaker

J-frame 250 A Electronic Trip Mission Critical Circuit Breakers (480/277 Vac) With Factory Sealed Trip Units Suitable for Reverse Connection▲

Electronic Trip Unit Type	Trip Function	Trip Unit	Continuous Current	D Interrupting	G Interrupting	J Interrupting	L Interrupting	Terminal
				Cat. No.	Cat. No.	Cat. No.	Cat. No.	
Standard	LI	3.2W	250	JDA34250WU31X	JGA34250WU31X	JJA34250WU31X	JLA34250WU31X	AL250JD■
Standard	LSI	3.2S-W	250	JDA34250WU33X	JGA34250WU33X	JJA34250WU33X	JLA34250WU33X	AL250JD■
High Perf. Ammeter	LSI	5.2A-W	250	JDA34250WU43X	JGA34250WU43X	JJA34250WU43X	JLA34250WU43X	AL250JD■
High Perf. Energy	LSI	5.2E-W	250	JDA34250WU53X	JGA34250WU53X	JJA34250WU53X	JLA34250WU53X	AL250JD■
High Perf. Ammeter	LSIG	6.2A-W	250	JDA34250WU44X	JGA34250WU44X	JJA34250WU44X	JLA34250WU44X	AL250JD■
High Perf. Energy	LSIG	6.2E-W	250	JDA34250WU54X	JGA34250WU54X	JJA34250WU54X	JLA34250WU54X	AL250JD■

▲ Standard rated (80%). Not available in 100% rated.
 ■ AL250JD terminal wire range is (1) 3/0 AWG–350 kcmil Al or Cu.

L-Frame Mission Critical Circuit Breaker

L-frame 600 A Electronic Trip Mission Critical Circuit Breakers (480/277 Vac) With Factory Sealed Trip Units Suitable for Reverse Connection▲

Electronic Trip Unit Type	Trip Function	Trip Unit	Continuous Current	D Interrupting	G Interrupting	J Interrupting	L Interrupting	Terminal
				Cat. No.	Cat. No.	Cat. No.	Cat. No.	
Standard	LI	3.3W	250	LDA34250WU31X	LGA34250WU31X	LJA34250WU31X	LLA34250WU31X	AL400L61K3■
			400	LDA34400WU31X	LGA34400WU31X	LJA34400WU31X	LLA34400WU31X	AL600LF52K3◆
			600	LDA34600WU31X	LGA34600WU31X	LJA34600WU31X	LLA34600WU31X	AL600LF52K3◆
Standard	LSI	3.3S-W	250	LDA34250WU33X	LGA34250WU33X	LJA34250WU33X	LLA34250WU33X	AL400L61K3■
			400	LDA34400WU33X	LGA34400WU33X	LJA34400WU33X	LLA34400WU33X	AL600LF52K3◆
			600	LDA34600WU33X	LGA34600WU33X	LJA34600WU33X	LLA34600WU33X	AL600LF52K3◆
High Perf. Ammeter	LSI	5.3A-W	400	LDA34400WU43X	LGA34400WU43X	LJA34400WU43X	LLA34400WU43X	AL600LF52K3◆
High Perf. Energy	LSI	5.3E-W	400	LDA34400WU53X	LGA34400WU53X	LJA34400WU53X	LLA34400WU53X	AL600LF52K3◆
High Perf. Ammeter	LSIG	6.3A-W	400	LDA34400WU44X	LGA34400WU44X	LJA34400WU44X	LLA34400WU44X	AL600LF52K3◆
High Perf. Energy	LSIG	6.3E-W	400	LDA34400WU54X	LGA34400WU54X	LJA34400WU54X	LLA34400WU54X	AL600LF52K3◆

▲ Standard rated (80%). Not available in 100% rated.
 ■ AL400L61K3 terminal wire range is (1) #2 AWG–500 kcmil Al or #2 AWG–600 kcmil Cu.
 ◆ AL600LF52K3 terminal wire range is (2) #3/0 AWG–500 kcmil Al or Cu.

PowerPact™ H-, J-, and L-frame Automatic Molded Case Switches, 600 Vac

Circuit Breaker	Poles	Ampere Rating	G Withstand		L Withstand		R Withstand		Terminal	Wire Range
			Cat. No.	Trip Point	Cat. No.	Trip Point	Cat. No.	Trip Point		
H-frame J-frame	2	150 A	HGA26000S15	2250 A	HLA26000S15	2250 A	—	—	—	—
		175 A	JGA26000S17	3125 A	JLA26000S17	3125 A	—	—	—	—
		250 A	JGA26000S25	3125 A	JLA26000S25	3125 A	—	—	—	—
J-frame	3	150 A	HGA36000S15	2250 A	HLA36000S15	2250 A	—	—	AL150HD	14 AWG–3/0 AWG Al/Cu
		175 A	JGA36000S17	3125 A	JLA36000S17	3125 A	JRA36000S17	3125 A	AL175JD	4–4/0 AWG Al/Cu
		250 A	JGA36000S25	3125 A	JLA36000S25	3125 A	JRA36000S25	3125 A	AL250JD	3/0 AWG–350 kcmil Al/Cu
L-frame	3	400 A	LGA36000S40X	4800 A	LLA36000S40X	4800 A	LRA36000S40X	4800 A	AL150HD	AL600LS52K3
		600 A	LGA36000S60X	6600 A	LLA36000S60X	6600 A	LRA36000S60X	6600 A	AL250JD	(2) 2/0 AWG–500 kcmil Al/Cu

Interrupt Ratings (kA)

	D	G	J	L	R
240 V	25	65	100	125	200
480 V	18	35	65	100	100
600 V	14	18	25	50	100

Phase Options—Example HDA26150()

Phase Option Number	Phase Connection	2-pole	3-pole
1	AB	HDA261501	—
2	AC	HDA261502	—
3	BA	HDA261503	—
4	BC	HDA261504	—
5	CA	HDA261505	—
6	CB	HDA261506	—
Standard	ABC	—	JDA36250
6	CBA	—	JDA362506

DE5 PANELBOARDS

Panelboards

I-Line® – L-Frame Circuit Breakers, Thermal-Magnetic

Ampere Rating	AC Magnetic Trip Settings Amperes		Two Pole		Three Pole		Standard Lug Kit Wire Range
			Catalogue No.	Price	Catalogue No.	Price	
LA Standard Interrupting							
	Low	High	600Vac, 250Vdc*		600Vac, 250Vdc		
125	625	1250	LA26125()		LA36125		
150	750	1500	LA26150()		LA36150		
175	875	1750	LA26175()		LA36175		
200	1000	2000	LA26200()		LA36200		AL400LA
225	1125	2250	LA26225()		LA36225		1-#1-600 kcmil or 2-#1-250 kcmil
250	1250	2500	LA26250()		LA36250		
300	1500	3000	LA26300()		LA36300		
350	1750	3500	LA26350()		LA36350		
400	2000	4000	LA26400()		LA36400		
LH High Interrupting							
	Low	High	600Vac, 250Vdc*		600Vac, 250Vdc		
125	625	1250	LH26125()		LH36125		
150	750	1500	LH26150()		LH36150		
175	875	1750	LH26175()		LH36175		
200	1000	2000	LH26200()		LH36200		AL400LA
225	1125	2250	LH26225()		LH36225		1-#1-600 kcmil or 2-#1-250 kcmil
250	1250	2500	LH26250()		LH36250		
300	1500	3000	LH26300()		LH36300		
350	1750	3500	LH26350()		LH36350		
400	2000	4000	LH26400()		LH36400		

* 2-pole circuit breaker catalog numbers are completed by adding required phase connection letters as suffix to catalog number.

CSA Listed Interrupting Rating Amperes

Breaker Catalogue No.	System Voltage AC		
	240	480	600
Prefix			
LA	42k	30k	22k
LH	65k	35k	25k

DE5
PANELBOARDS

Panelboards

I-Line® – PowerPact L- and M-frame Circuit Breakers

PowerPact L-Frame 600A Circuit Breakers with Factory Sealed Electronic Trip Units Suitable for Reverse Connection

Electronic Trip Unit			D Interrupting		G Interrupting		J Interrupting ◆		L Interrupting ◆		R Interrupting ◆		Terminal
Type	Function	Trip Unit	Amps	Catalogue Number ■	Price	Catalogue Number ■	Price	Catalogue Number ■	Price	Catalogue Number ■	Price	Catalogue Number ■	
Micrologic Standard	LI	3.3★	250	LDA36250U31X		LGA36250U31X		LJA36250U31X		LLA36250U31X		LRA36250U31X	AL400L61K3▼
			400	LDA36400U31X		LGA36400U31X		LJA36400U31X		LLA36400U31X		LRA36400U31X	AL600LF52K3△
			600	LDA36600U31X		LGA36600U31X		LJA36600U31X		LLA36600U31X		LRA36600U31X	
Micrologic Standard	LSI	3.3S★	250	LDA36250U33X		LGA36250U33X		LJA36250U33X		LLA36250U33X		LRA36250U33X	AL400L61K3▼
			400	LDA36400U33X		LGA36400U33X		LJA36400U33X		LLA36400U33X		LRA36400U33X	
			600	LDA36600U33X		LGA36600U33X		LJA36600U33X		LLA36600U33X		LRA36600U33X	
Micrologic Ammeter	LSI	5.3A	400	LDA36400U43X		LGA36400U43X		LJA36400U43X		LLA36400U43X		LRA36400U43X	
			600	LDA36600U43X		LGA36600U43X		LJA36600U43X		LLA36600U43X		LRA36600U43X	
			400	LDA36400U53X		LGA36400U53X		LJA36400U53X		LLA36400U53X		LRA36400U53X	
Micrologic Energy	LSI	5.3E	600	LDA36600U53X		LGA36600U53X		LJA36600U53X		LLA36600U53X		LRA36600U53X	
			400	LDA36400U44X		LGA36400U44X		LJA36400U44X		LLA36400U44X		LRA36400U44X	
			600	LDA36600U44X		LGA36600U44X		LJA36600U44X		LLA36600U44X		LRA36600U44X	
Micrologic Ammeter	LSIG	6.3A	400	LDA36400U54X		LGA36400U54X		LJA36400U54X		LLA36400U54X		LRA36400U54X	
			600	LDA36600U54X		LGA36600U54X		LJA36600U54X		LLA36600U54X		LRA36600U54X	
			400	LDA36400U54X		LGA36400U54X		LJA36400U54X		LLA36400U54X		LRA36400U54X	
Micrologic Energy	LSIG	6.3E	600	LDA36600U54X		LGA36600U54X		LJA36600U54X		LLA36600U54X		LRA36600U54X	

- For 100% rated circuit breakers (250 A and 400 A only), add a "C" in the 9th character place (for example, LRA36400CU31X).
- ◆ Circuit breakers with J, L, and R interrupting ratings are CSA/UL certified as current limiting.
- ★ 3P circuit breakers with this trip unit can be used for 2P applications.
- ▼ AL400L61K3 terminal wire ranges are (1) 2 AWG–600 kcmil Cu or 1) 2 AWG–500 kcmil Al.
- △ AL600LF52K3 terminal wire range is (2) 3/0 AWG–500 kcmil Al/Cu.

Powerpact M -Frame 800A with ET1.0 Trip Unit (factory sealed, not field adjustable)

Ampere Rating	Adjustable Instantaneous Trip Range		G Interrupting	J Interrupting	Terminal Wire Range
	Low	High			
300	600	3000	MGA26300()	MJA26300()	
350	700	3500	MGA26350()	MJA26350()	
400	800	4000	MGA26400()	MJA26400()	
450	900	4500	MGA26450()	MJA26450()	AL800M23K
500	1000	5000	MGA26500()	MJA26500()	3-#3/0-500 kcmil
600	1200	6000	MGA26600()	MJA26600()	
700	1400	7000	MGA26700()	MJA26700()	
800	1600	8000	MGA26800()	MJA26800()	
300	600	3000	MGA36300	MJA36300	
350	700	3500	MGA36350	MJA36350	
400	800	4000	MGA36400	MJA36400	
450	900	4500	MGA36450	MJA36450	AL800M23K
500	1000	5000	MGA36500	MJA36500	3-#3/0-500 kcmil
600	1200	6000	MGA36600	MJA36600	
700	1400	7000	MGA36700	MJA36700	
800	1600	8000	MGA36800	MJA36800	

- CSA/UL magnetic trip setting tolerances are ±10% from the nominal values shown.
- * Fill in parentheses with the following phase connection options: (2) for AC and (5) for CA.

Interrupt Ratings (kA)

Voltage	Interrupt Ratings (kA)	
	G	J
240 V	65	100
480 V	35	65
600 V	18	25

Automatic Molded Case Switches—600 Vac, 50/60 Hz

Ampere Rating	2-pole		3-pole		Withstand Rating ◆			Terminal Wire Range
	Catalogue Number □		Catalogue Number		240 Vac	480 Vac	600 Vac	
600 A	PJA26000S60()		PJA36000S60		100	65	25	3-3/0 through 500 kcmil Al or Cu
800 A	PJA26000S80()		PJA36000S80		100	65	25	
1000 A	PJA26000S10()		PJA36000S10		100	65	25	4-3/0 through 500 kcmil Al or Cu
1200 A	PJA26000S12()		PJA36000S12		100	65	25	

- ◆ The withstand rating is the fault current, at rated voltage, that the molded case switch will withstand without damage when protected by a circuit breaker with an equal ampere rating.
- Fill in parentheses with the following phase connection options: (2) for AC or (5) for CA.

PowerPact P- and R-frame Interrupt Ratings

Voltage	P-frame Interrupt Rating				R-frame Interrupt Rating			
	G	J	K	L	G	J	K	L
240 Vac	65 kA	100 kA	65 kA	125 kA	65 kA	100 kA	65 kA	125 kA
480 Vac	35 kA	65 kA	50 kA	100 kA	35 kA	65 kA	65 kA	100 kA
600 Vac	18 kA	25 kA	50 kA	---	18 kA	25 kA	65 kA	50 kA

Panelboards

I-Line® – PowerPact P- and R-frame Circuit Breakers

PowerPact P Frame – 1200A (600Vac, 50/60 Hz) 3P Circuit Breakers with Electronic Trip Units											
Electronic Trip Unit			Sensor Rating	Amps	G Interrupting		J Interrupting		K Interrupting		Terminal wire range
Type	Function	Code			Catalogue Number ■	Catalogue Number ■	Catalogue Number ■	Catalogue Number ■▲			
Basic Electronic Trip Unit (Not Interchangeable)	Fixed long-time, Adjustable Instantaneous	ET1.0I	600 A	600	PGA36060	PJA36060	PKA36060	PLA34060	(3) 3/0 AWG–500 kcmil Al or Cu		
			800 A	800	PGA36080	PJA36080	PKA36080	PLA34080	AL800M23K		
			1000 A	1000	PGA36100	PJA36100	PKA36100	PLA34100	(4) 3/0 AWG–500 kcmil Al or Cu		
			1200 A	1200	PGA36120	PJA36120	PKA36120	PLA34120	AL1200P24K		
Micrologic Interchangeable Standard Trip Unit	LI	3.0	250 A	250	PGA36025U31A	PJA36025U31A	PKA36025U31A	PLA34025U31A	(3) 3/0 AWG–500 kcmil Al or Cu		
			400 A	400	PGA36040U31A	PJA36040U31A	PKA36040U31A	PLA34040U31A	AL800M23K		
			600 A	600	PGA36060U31A	PJA36060U31A	PKA36060U31A	PLA34060U31A			
			800 A	800	PGA36080U31A	PJA36080U31A	PKA36080U31A	PLA34080U31A			
			1000 A	1000	PGA36100U31A	PJA36100U31A	PKA36100U31A	PLA34100U31A	(4) 3/0 AWG–500 kcmil Al or Cu		
			1200 A	1200	PGA36120U31A	PJA36120U31A	PKA36120U31A	PLA34120U31A	AL1200P24K		
	LSI	5.0	250 A	250	PGA36025U33A	PJA36025U33A	PKA36025U33A	PLA34025U33A	(3) 3/0 AWG–500 kcmil Al or Cu		
			400 A	400	PGA36040U33A	PJA36040U33A	PKA36040U33A	PLA34040U33A	AL800M23K		
			600 A	600	PGA36060U33A	PJA36060U33A	PKA36060U33A	PLA34060U33A			
			800 A	800	PGA36080U33A	PJA36080U33A	PKA36080U33A	PLA34080U33A			
			1000 A	1000	PGA36100U33A	PJA36100U33A	PKA36100U33A	PLA34100U33A	(4) 3/0 AWG–500 kcmil Al or Cu		
			1200 A	1200	PGA36120U33A	PJA36120U33A	PKA36120U33A	PLA34120U33A	AL1200P24K		
Micrologic Interchangeable Ammeter Trip Unit	LI	3.0A	250 A	250	PGA36025U41A	PJA36025U41A	PKA36025U41A	PLA34025U41A	(3) 3/0 AWG–500 kcmil Al or Cu		
			400 A	400	PGA36040U41A	PJA36040U41A	PKA36040U41A	PLA34040U41A	AL800M23K		
			600 A	600	PGA36060U41A	PJA36060U41A	PKA36060U41A	PLA34060U41A			
			800 A	800	PGA36080U41A	PJA36080U41A	PKA36080U41A	PLA34080U41A			
			1000 A	1000	PGA36100U41A	PJA36100U41A	PKA36100U41A	PLA34100U41A	(4) 3/0 AWG–500 kcmil Al or Cu		
			1200 A	1200	PGA36120U41A	PJA36120U41A	PKA36120U41A	PLA34120U41A	AL1200P24K		
	LSI	5.0A	250 A	250	PGA36025U43A	PJA36025U43A	PKA36025U43A	PLA34025U43A	(3) 3/0 AWG–500 kcmil Al or Cu		
			400 A	400	PGA36040U43A	PJA36040U43A	PKA36040U43A	PLA34040U43A	AL800M23K		
			600 A	600	PGA36060U43A	PJA36060U43A	PKA36060U43A	PLA34060U43A			
			800 A	800	PGA36080U43A	PJA36080U43A	PKA36080U43A	PLA34080U43A			
			1000 A	1000	PGA36100U43A	PJA36100U43A	PKA36100U43A	PLA34100U43A	(4) 3/0 AWG–500 kcmil Al or Cu		
			1200 A	1200	PGA36120U43A	PJA36120U43A	PKA36120U43A	PLA34120U43A	AL1200P24K		
	LSIG	6.0A	250 A	250	PGA36025U44A	PJA36025U44A	PKA36025U44A	PLA34025U44A	(3) 3/0 AWG–500 kcmil Al or Cu		
			400 A	400	PGA36040U44A	PJA36040U44A	PKA36040U44A	PLA34040U44A	AL800M23K		
			600 A	600	PGA36060U44A	PJA36060U44A	PKA36060U44A	PLA34060U44A			
			800 A	800	PGA36080U44A	PJA36080U44A	PKA36080U44A	PLA34080U44A			
			1000 A	1000	PGA36100U44A	PJA36100U44A	PKA36100U44A	PLA34100U44A	(4) 3/0 AWG–500 kcmil Al or Cu		
			1200 A	1200	PGA36120U44A	PJA36120U44A	PKA36120U44A	PLA34120U44A	AL1200P24K		
Micrologic Interchangeable Power Trip Unit	LSI	5.0P	250 A	250	PGA36025U63AE1	PJA36025U63AE1	PKA36025U63AE1	PLA34025U63AE1	(3) 3/0 AWG–500 kcmil Al or Cu		
			400 A	400	PGA36040U63AE1	PJA36040U63AE1	PKA36040U63AE1	PLA34040U63AE1	AL800M23K		
			600 A	600	PGA36060U63AE1	PJA36060U63AE1	PKA36060U63AE1	PLA34060U63AE1			
			800 A	800	PGA36080U63AE1	PJA36080U63AE1	PKA36080U63AE1	PLA34080U63AE1			
			1000 A	1000	PGA36100U63AE1	PJA36100U63AE1	PKA36100U63AE1	PLA34100U63AE1	(4) 3/0 AWG–500 kcmil Al or Cu		
			1200 A	1200	PGA36120U63AE1	PJA36120U63AE1	PKA36120U63AE1	PLA34120U63AE1	AL1200P24K		
	LSIG	6.0P	250 A	250	PGA36025U64AE1	PJA36025U64AE1	PKA36025U64AE1	PLA34025U64AE1	(3) 3/0 AWG–500 kcmil Al or Cu		
			400 A	400	PGA36040U64AE1	PJA36040U64AE1	PKA36040U64AE1	PLA34040U64AE1	AL800M23K		
			600 A	600	PGA36060U64AE1	PJA36060U64AE1	PKA36060U64AE1	PLA34060U64AE1			
			800 A	800	PGA36080U64AE1	PJA36080U64AE1	PKA36080U64AE1	PLA34080U64AE1			
			1000 A	1000	PGA36100U64AE1	PJA36100U64AE1	PKA36100U64AE1	PLA34100U64AE1	(4) 3/0 AWG–500 kcmil Al or Cu		
			1200 A	1200	PGA36120U64AE1	PJA36120U64AE1	PKA36120U64AE1	PLA34120U64AE1	AL1200P24K		
Micrologic Interchangeable Harmonic Trip Unit	LSI	5.0H	250 A	250	PGA36025U73AE1	PJA36025U73AE1	PKA36025U73AE1	PLA34025U73AE1	(3) 3/0 AWG–500 kcmil Al or Cu		
			400 A	400	PGA36040U73AE1	PJA36040U73AE1	PKA36040U73AE1	PLA34040U73AE1	AL800M23K		
			600 A	600	PGA36060U73AE1	PJA36060U73AE1	PKA36060U73AE1	PLA34060U73AE1			
			800 A	800	PGA36080U73AE1	PJA36080U73AE1	PKA36080U73AE1	PLA34080U73AE1			
			1000 A	1000	PGA36100U73AE1	PJA36100U73AE1	PKA36100U73AE1	PLA34100U73AE1	(4) 3/0 AWG–500 kcmil Al or Cu		
			1200 A	1200	PGA36120U73AE1	PJA36120U73AE1	PKA36120U73AE1	PLA34120U73AE1	AL1200P24K		
	LSIG	6.0H	250 A	250	PGA36025U74AE1	PJA36025U74AE1	PKA36025U74AE1	PLA34025U74AE1	(3) 3/0 AWG–500 kcmil Al or Cu		
			400 A	400	PGA36040U74AE1	PJA36040U74AE1	PKA36040U74AE1	PLA34040U74AE1	AL800M23K		
			600 A	600	PGA36060U74AE1	PJA36060U74AE1	PKA36060U74AE1	PLA34060U74AE1			
			800 A	800	PGA36080U74AE1	PJA36080U74AE1	PKA36080U74AE1	PLA34080U74AE1			
			1000 A	1000	PGA36100U74AE1	PJA36100U74AE1	PKA36100U74AE1	PLA34100U74AE1	(4) 3/0 AWG–500 kcmil Al or Cu		
			1200 A	1200	PGA36120U74AE1	PJA36120U74AE1	PKA36120U74AE1	PLA34120U74AE1	AL1200P24K		

■ For 250-800A 100% rated circuit breakers add a "C" in the 9th character place. For example, the catalog number for a 100% standard-type trip unit with LI trip functions at 250A would be PGA36025CU31A. 100% rating is not available for 600-800A P-Frame MCCB with Basic Electronic TU and all 1000-1200A P-Frame MCCB.

▲ The L interrupt rating is supplied in 480 V only; for example, PLA34025U31A.

PowerPact R Frame – 1200A (600 Vac, 50/60 Hz) 3P Circuit Breaker with Electronic Trip Unit, 100% Rated

Amps	Trip Unit	Trip Function	G Interrupting Catalogue Number	J Interrupting Catalogue Number	K Interrupting Catalogue Number	L Interrupting Catalogue Number	Terminal wire range
1200	Basic Electronic Non-interchangeable	Fixed Long-Time, Adjustable Instantaneous	RGA36120	RJA36120	RKA36120	RLA36120	AL1200R53K (4) 3/0-600 kcmil Al or Cu
1000	Standard	3.0 LI	RGA36100CU31A	RJA36100CU31A	RKA36100CU31A	RLA36100CU31A	
		5.0 LSI	RGA36100CU33A	RJA36100CU33A	RKA36100CU33A	RLA36100CU33A	
		3.0A LI	RGA36100CU41A	RJA36100CU41A	RKA36100CU41A	RLA36100CU41A	
	Ammeter	5.0A LSI	RGA36100CU43A	RJA36100CU43A	RKA36100CU43A	RLA36100CU43A	
		6.0A LSIG	RGA36100CU44A	RJA36100CU44A	RKA36100CU44A	RLA36100CU44A	
		5.0P LSI	RGA36100CU63AE1	RJA36100CU63AE1	RKA36100CU63AE1	RLA36100CU63AE1	
1200	Power	6.0P LSIG	RGA36100CU64AE1	RJA36100CU64AE1	RKA36100CU64AE1	RLA36100CU64AE1	
		5.0H LSI	RGA36100CU73AE1	RJA36100CU73AE1	RKA36100CU73AE1	RLA36100CU73AE1	
		6.0H LSIG	RGA36100CU74AE1	RJA36100CU74AE1	RKA36100CU74AE1	RLA36100CU74AE1	
	Standard	3.0 LI	RGA36120CU31A	RJA36120CU31A	RKA36120CU31A	RLA36120CU31A	
		5.0 LSI	RGA36120CU33A	RJA36120CU33A	RKA36120CU33A	RLA36120CU33A	
		3.0A LI	RGA36120CU41A	RJA36120CU41A	RKA36120CU41A	RLA36120CU41A	
Ammeter	5.0A LSI	RGA36120CU43A	RJA36120CU43A	RKA36120CU43A	RLA36120CU43A		
	6.0A LSIG	RGA36120CU44A	RJA36120CU44A	RKA36120CU44A	RLA36120CU44A		
	5.0P LSI	RGA36120CU63AE1	RJA36120CU63AE1	RKA36120CU63AE1	RLA36120CU63AE1		
Power	6.0P LSIG	RGA36120CU64AE1	RJA36120CU64AE1	RKA36120CU64AE1	RLA36120CU64AE1		
	5.0H LSI	RGA36120CU73AE1	RJA36120CU73AE1	RKA36120CU73AE1	RLA36120CU73AE1		
	6.0H LSIG	RGA36120CU74AE1	RJA36120CU74AE1	RKA36120CU74AE1	RLA36120CU74AE1		

Panelboards

I-Line® – Circuit Breaker Type

Factory Assembled Panels

600 Vac, 250 Vdc Max.
1200 Amp Mains Max.

The table below is intended as a quick reference for our I-Line Factory Assembled offer. For complete details please consult the I-Line panelboard product selector in Q2C or EQM, or contact your Schneider Electric sales representative.

I-LINE Panelboard Types - Factory assembled offer (FA)

Type	Amp Rating/ Main type	Branch Mounting Inches	Avail. w/ Vertical Main?	Encl. W x D inches	Encl. Heights inches	Left Side Branch Types	Right Side Branch Types
HCM	225 MB, MLO 400 MB, MLO 600 MB, MLO 800 MB, MLO	MLO: 27, 45, 63, 99 VMB: 27, 36, 45, 54, 72, 81	Yes, except H frame and J frame	32 x 8.25(9.5)	48, 64, 73, 91	QB, QD, QG, QJ FA, FH FG, FJ, FK, HD, HG, HJ, HL, HR JD, JG, JJ, JL, JR	QB, QD, QG, QJ FA, FH, HD, HG, HJ, HL, HR FJ, FK JD, JG, JJ, JL, JR
HCP-SU	800 MLO/MB	54	No	26 x 9.5	86	FA, FH FG, FJ, FK QB, QD, QG, QJ HD, HG, HJ, HL, HR, LD, LG, LJ, LL, LR, LA, LH, MG, MJ PG, PJ, PL, PK, PGC, PJC, PLC	Single row - no branches on right side
HCP	400 MLO 600 MLO 800 MLO 1200 MLO	27, 45, 63, 99	No	42 x 9.5	50, 59, 68, 86	FA, FH FG, FJ, FK QB, QD, QG, QJ HD, HG, HJ, HL, HR, JD, JG, JJ, JL, JR, LD, LG, LJ, LL, LR, LA, LH, MG, MJ PG, PJ, PL, PK, PGC, PJC, PLC to 800A max	FA, FH FJ, FK, HD, HG, HJ, HL, HR QB, QD, QG, QJ JD, JG, JJ, JL, JR
HCP	600 MB 800 MB	36, 72	Yes	42 x 9.5	68, 86	FA, FH FG, FJ, FK QB, QD, QG, QJ HD, HG, HJ, HL, HR, JD, JG, JJ, JL, JR, LD, LG, LJ, LL, LA, LH, MG, MJ	FA, FH FJ, FK, HD, HG, HJ, HL, HR QB, QD, QG, QJ JD, JG, JJ, JL, JR
HCR-U	1200 MLO/MB	108 incl. BFM/MB	No	44 x 9.5	86	FA, FH FJ, FK QB, QD, QG, QJ HD, HG, HJ, HL, HR, JD, JG, JJ, JL, JR, LD, LG, LJ, LL, LR, LA, LH, MG, MJ, PG, PJ, PL, PK, PGC, PJC, PLC, RGC, RJC, RKC, RLC to 1200 max	FA, FH FJ, FK, HD, HG, HJ, HL, HR QB, QD, QG, QJ JD, JG, JJ, JL, JR

Notes:
VMB - Vertically mounted main breaker
BFM - Back-fed main breaker

* For pricing information on the Factory Assembled offer please refer to the I-Line panelboard product selector in Q2C or EQM, or contact your Schneider Electric sales representative.

I-LINE 200% Rated Neutral—Standard Terminal Configuration □

Panel Type	Ampacity	Type	Branch Space		Neutral Terminals Quantity & Size		Type 1 Enclosure							
			IN	mm	Main	Branch	H		W		D			
							IN	mm	IN	mm	IN	mm		
HCM	600 A	MLO	72	1829	(8) 750 kcmil	(35) 350 kcmil (9) #14-1/0 (17) #14-#4	91.00	2311	32.00	813	8.25	210		
	800 A	MLO	72	1829									9.50	241
	600 A (MG, MJ)	M/B	72	1829										
	800 A (MG, MJ)	M/B	72	1829										
HCR-U	1200 A	Universal	108	2743	(8) 750 kcmil	(9) 600 kcmil (15) 350 kcmil (9) #14-1/0 (17) #14-#4	86.00	2184	44.00	1118	9.50	241		
HCP	600 A	M/B MLO	63	1600	(8) 750 kcmil	(35) 350 kcmil (9) #14-1/0 (17) #14-#4	68.00	1727	42.00	1067	9.50	241		
	800A	M/B, MLO	99	2515	(8) 750 kcmil	(35) 350 kcmil, (9)#14-1/0, (17)#14-#4	86	2184	42	1067	9.50	241		
HCP-SU	800 A	M/B MLO	54	1371	(8) 750 kcmil	(8) 750 kcmil (21) 350 kcmil (9) #14-1/0 (17) #14-#4	86.00	2184	26.00	660	9.50	241		

- Available in Type 1 enclosures only.
- ◇ 9" box extension is required for HCP-SU panelboard with 200% rated neutral
- 6" box extension is required for HCR-U panelboard with 200% rated neutral

Panelboards

I-Line[®] – Combo Panelboards

600 Vac, 250 Vdc Max.
 120/240 Vac Single Phase 3 Wire
 1200 Amp Mains Max.

Factory Assembled Panels

The I-Line Combo single phase and three phase panelboard, combines NQ for single phase and NQ or NF for three phase lighting section with an I-Line distribution section in a single panelboard. It is available in single or duplex configurations, which determine the number of included lighting sections. The I-Line Combo panelboards are designed to accept the following circuit breakers: FA, FH, FI, FY, HD, HG, HJ, HL, HR, JD, JG, JJ, JL, JR, LA, LH, LD, LG, LJ, LL, LR, MG, MJ, PG, PJ, PK, PL, Q4, QB, QG, QJ, EDB, EGB, EJB, QO and QOB.

Panelboard Configuration	I-Line Mounting Space	Maximum Ampage ²		Lighting Section Circuit Count		Nema 1 Dimensions in inches (mm)		
				Section 1	Section 2	Height	Width	Depth
Single	18 in. (457 mm)	600		30	—	86 (2184)	26 (660)	9.5 (241)
				42	—	86 (2184)	26 (660)	9.5 (241)
Single	22.5 in. (572 mm)	600		30	—	73 (1854)	32 (813)	9.5 (241)
				42	—	91 (2311)	32 (813)	9.5 (241)
Single	31.5 in. (800 mm)	MLO	MCB	42	42	86 ² (2184 ²)	41 (1118)	9.5 ² (241 ²)
		800	1200 ²	42	Optional Mounting Space ¹	86 ² (2184 ²)	41 (1118)	9.5 ² (241 ²)

¹ Optional mounting space is only available on 800 A interiors, not 1200 A.
² 1200 A unit has following dimensions: 92 in. (2337 mm) Height, 44 in. (1118 mm) Width, 12 in. (305 mm) Depth.
³ MCB for 48 Vdc is 400A max.

Enclosure Protection

Type 1, 3R*, 4/4X*, 5*, 12*

* Only available in 26 in. (660 mm) and 44 in. (1118 mm) width configurations up to 800A. 1200A unit has Type 1, 2 enclosure.

Features and Benefits

Reduced Footprint

By combining a power panel with up to two lighting panels in a single enclosure, the I-Line Combo panelboard saves significant space at any site.

Simple to Retrofit

I-Line Combo panelboard enclosures fit into the same footprint on sites where an existing I-Line power panelboard resides, providing easy upgrades of electrical equipment.

Flexible Circuit Breaker Configuration

Due to the I-Line Combo panelboard's ability to house I-Line molded case circuit breakers as well as cost effective miniature circuit breakers, it provides not only a more economical solution but an adaptable solution tailored to each customer.

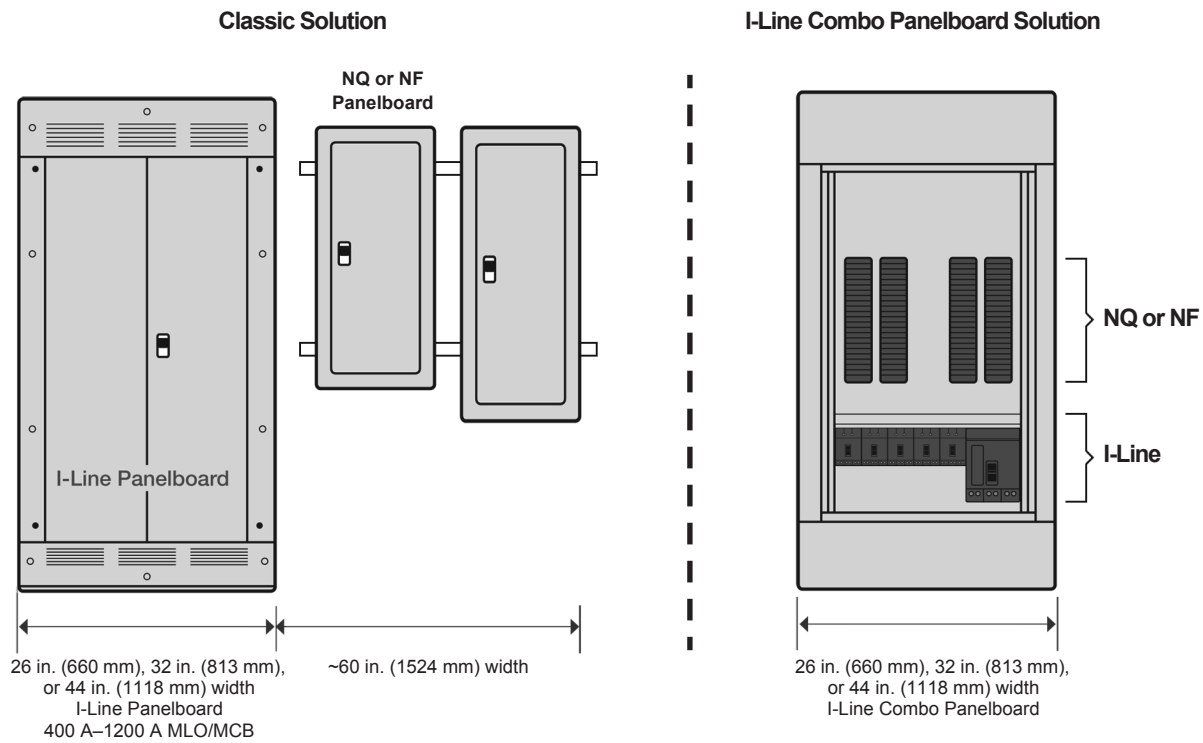

DE5 PANELBOARDS

Panelboards

QMB – Fusible Switch Type

Factory Assembled

600 Vac, 250 Vdc Max.
1200 Amp Mains Max.

I-LINE 200% Rated Neutral—Standard Terminal Configuration □



QMB Panelboard

QMB Fusible Power Panelboards deliver outstanding Square D quality to serve your Industrial, Commercial and other application needs.

To better match your requirements this panel is available exclusively Factory assembled.

Please contact your Schneider Electric sales professional or an authorized distributor for assistance.

DE5 PANELBOARDS

QMB Layout Information

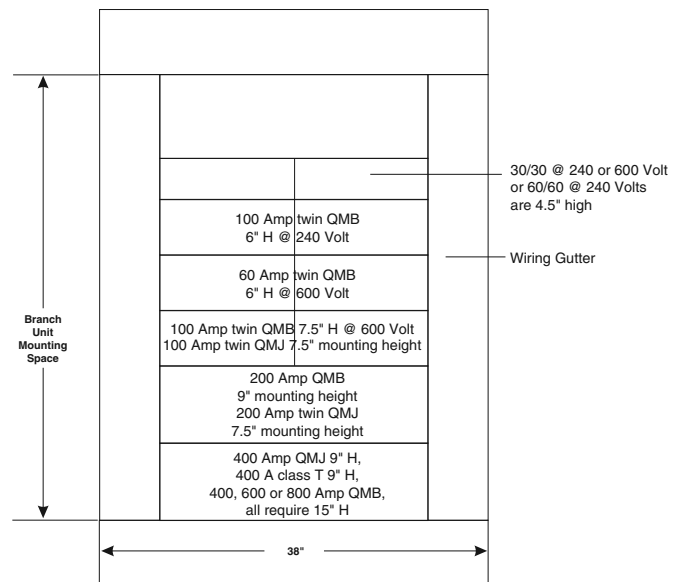

Application Information

- Lug data, page DE5-35.

Panelboards

QMB – Fusible Switch Type

Branch Switches and Accessories

Factory Assembled

QMB Branch Switch Units

Unit Ampere Rating	Unit Height (In.)	Catalogue Number	Class R Fuse Kits		Electrical Interlock Kit Catalogue Number ▲	Horsepower Ratings★												
			No. Kits Req'd.	Catalogue Number		240 Vac				480 Vac				600 Vac				250 Vdc
						Std.	Max.	1Ø	3Ø	1Ø	3Ø	1Ø	3Ø	1Ø	3Ø	1Ø	3Ø	
2-pole, 240 Vac																		
30 A-30 A	4.5	QMB221TW	2	HRK30	QMB300EK(1 or 2)	1.5	3	3	7.5	—	—	—	—	—	—	5		
30 A-Blank	4.5	QMB221HW■	1	—	—	—	—	—	—	—	—	—	—	—	—	5		
60 A-60 A	4.5	QMB222TW	1	QMB36R	QMB300EK(1 or 2)	3	7.5	10	15	—	—	—	—	—	—	10		
60 A-Blank	4.5	QMB222HW■	1	—	—	—	—	—	—	—	—	—	—	—	—	10		
100 A-100 A	6	QMB223TW	1	QMB100R	QMB610EK(1 or 2)	7.5	15	15	30	—	—	—	—	—	—	20		
100 A-Blank	6	QMB223HW■	1	—	—	—	—	—	—	—	—	—	—	—	—	20		
200 A	9	QMB224W	1	HRK1020	QMB200EK(1 or 2)	—	25	15	60	—	—	—	—	—	—	40		
400 A	15	QMB225W	1	QMB4060R	—	—	—	—	—	—	—	—	—	—	—	—		
600 A	Use 3-pole devices for 2-pole application.				—	—	—	—	—	—	—	—	—	—	—	—		
3-pole, 240 Vac																		
30 A-30 A	4.5	QMB321TW	2	HRK30	QMB300EK(1 or 2)	—	3	—	7.5	—	—	—	—	—	—	—		
30 A-Blank	4.5	QMB321HW■	1	—		—	—	3	—	7.5	—	—	—	—	—	—	—	
60 A-60 A	4.5	QMB322TW	1	QMB36R	QMB300EK(1 or 2)	—	7.5	—	15	—	—	—	—	—	—	—		
60 A-Blank	4.5	QMB322HW■	1	—		—	—	7.5	—	15	—	—	—	—	—	—	—	
100 A-100 A	6	QMB323TW	1	QMB100R	QMB610EK(1 or 2)	—	15	—	30	—	—	—	—	—	—	—		
100 A-Blank	6	QMB323HW■	1	—		—	—	15	—	30	—	—	—	—	—	—	—	
200 A	9	QMB324W	1	HRK1020	QMB200EK(1 or 2)	—	25	—	60	—	—	—	—	—	—	—		
400 A	15	QMB325W	1	QMB4060R	—	—	50	—	125	—	—	—	—	—	—	—		
400 A	9	QMB325WT3♦	—	—	—	—	50	—	—	—	—	—	—	—	—	—		
600 A	15	QMB326W	1	QMB4060R	—	—	75	—	150	—	—	—	—	—	—	—		
600 A	15	QMB326WT3♦	—	—	—	—	75	—	—	—	—	—	—	—	—	—		
800 A	15	QMB327WT3♦	—	—	—	—	75	—	—	—	—	—	—	—	—	—		
2-pole, 600 Vac, 250 Vdc★																		
30 A-30 A	4.5	QMB261TW	1	QMB36R	QMB300EK(1 or 2)	1.5	—	3	—	3	5	7.5	15	3	—	10	—	5
30 A-Blank	4.5	QMB261HW■	1	—	—	—	—	—	—	—	—	—	—	—	—	—	—	—
60 A-60 A	6	QMB262TW	1	QMB60R	QMB610EK(1 or 2)	3	—	10	—	5	15	20	30	10	—	25	—	10
60 A-Blank	6	QMB262HW■	1	—		—	—	—	—	—	—	—	—	—	—	—	—	—
100 A-100 A	7.5	QMB263TW	2	HRK1020	QMB610EK(1 or 2)	7.5	—	15	—	10	25	30	60	15	—	40	—	20
100 A-Blank	7.5	QMB263HW■	1	—		—	—	—	—	—	—	—	—	—	—	—	—	—
200 A	9	QMB264W	1	HRK1020	QMB200EK(1 or 2)	15	—	—	—	25	50	50	125	30	—	50	—	40
400 A	Use 3-pole devices for 2-pole application.				—	—	—	—	—	—	—	—	—	—	—	—	—	—
600 A▼	Use 3-pole devices for 2-pole application.				—	—	—	—	—	—	—	—	—	—	—	—	—	—
3-pole, 600 Vac★																		
30 A-30 A	4.5	QMB361TW	1	QMB36R	QMB300EK(1 or 2)	—	3	—	7.5	—	5	—	15	—	7.5	—	20	—
30 A-Blank	4.5	QMB361HW■	1	—	—	—	—	—	—	—	—	—	—	—	—	—	—	—
60 A-60 A	6	QMB362TW	1	QMB60R	QMB300EK(1 or 2)	—	3	—	7.5	—	5	—	15	—	7.5	—	20	—
60 A-Blank	6	QMB362HW■	1	—	—	—	—	—	—	—	—	—	—	—	—	—	—	—
60 A-60 A	6	QMB362T	—	—	QMB610EK(1 or 2)	—	7.5	—	15	—	15	—	30	—	15	—	50	—
60 A-Blank	6	QMB362HW■	1	QMB60R	QMB610EK(1 or 2)	—	7.5	—	15	—	15	—	30	—	15	—	50	—
60 A-30 A	6	QMB362T21W	1 ea.	QMB60R and QMB36R	QMB610EK(1 or 2)	—	—	—	—	—	—	—	—	—	—	—	—	—
100 A-100 A	7.5	QMB363TW	2	HRK1020	QMB610EK(1 or 2)	—	15	—	30	—	25	—	60	—	30	—	75	—
100 A-Blank	7.5	QMB363HW■	1	HRK1020	QMB610EK(1 or 2)	—	15	—	30	—	25	—	60	—	30	—	75	—
100 A-30 A	7.5	QMB363T31W	1 ea.	HRK1020 and QMB36R	QMB610EK(1 or 2)	—	—	—	—	—	—	—	—	—	—	—	—	—
100 A-60 A	7.5	QMB363T32W	1 ea.	HRK1020 and QMB60R	QMB610EK(1 or 2)	—	—	—	—	—	—	—	—	—	—	—	—	—
200 A	9	QMB364W	1	HRK1020	QMB200EK(1 or 2)	—	25	—	60	—	50	—	125	—	60	—	150	—
200 A-200 A	7.5	QMJ364T	—	—	QMB610EK(1 or 2)	—	25	—	60	—	50	—	125	—	60	—	150	—
200 A-Blank	7.5	QMJ364H■	—	—	—	—	—	—	—	—	—	—	—	—	—	—	—	—
400 A△	15	QMB365W	1	QMB4060R	—	—	—	—	—	—	100	—	250	—	125	—	350	50
400 A	9	QMJ365	—	—	QMB200EK(1 or 2)	—	50	—	125	—	100	—	250	—	125	—	350	50
400 A△	9	QMB365WT6◇	—	—	—	—	—	—	—	—	—	—	—	—	—	—	—	—
600 A▼△	15	QMB366W	1	QMB4060R	—	—	—	—	—	—	150	—	400	—	250	—	500	—
600 A	15	QMJ366	—	—	—	—	75	—	150	—	—	—	—	—	—	—	—	—
800 A□	15	QMB367W	—	—	—	—	—	—	—	—	150	—	400	—	250	—	500	—

- ▲ "1" indicates one normally open and one normally closed contact.
- ▲ "2" indicates two normally open and two normally closed contacts.
- Blank units cannot be modified to accept a switch interior.
- ♦ Use 300 Vac Class T fuses only.
- ★ Class J fuse provisions—to field modify switch, move load side fuse base to position indicated in switch. Not available on 100-30, 100-60, or 800 A switch units.
- ▼ To adapt switch for 600 Vac Class T fuses, order kit Catalogue Number **QMB600T6**. (Use T6 fuses with standard horsepower ratings only).
- △ 250 Vdc rating.
- To adapt switch for 600 Vac Class T fuses, order kit Catalogue Number **QMB800T6**. (Use T6 fuses with standard horsepower ratings only).
- ◇ Use 600 Vac Class T fuses only.
- ★ Horsepower rating applicable to 3ph 4W Y system only.

DE5 PANELBOARDS

Panelboards QMB - Fusible Switch Type

Factory Assembled

QMB Factory Assembled Panelboards

Main Lugs		Main Switch ▲	
Mains Rating (Amperes)	Maximum Mounting Space (In.)	Mains Rating (Amperes)	Maximum Mounting Space (In.)
—	—	100	51
—	—	200	51
225	60	—	—
400	60	400	45
600	60	600	45
800	60	800■	45
1200	45	—	—

- ▲ Class J fuses available only on 600 V switches.
- 800 A switch unit with provision for CSA/UL Class L fuses.

Standard Mechanical Lugs—Main Lugs

Panel Type	Mains Ampere Rating	Lug Wire Range ▲	Wire Range Wire Bending Space per CSA ▲
QMB	225 A	one #6–300 kcmil Al or Cu	one #6–300 kcmil Al or Cu
	400 A	one #6–300 kcmil Al or Cu and, one 3/0–750 kcmil Al or Cu	one #6–300 kcmil Al or Cu and, one 3/0–750 kcmil Al or Cu
	600 A	two 3/0–500 kcmil Al or Cu	two 3/0–500 kcmil Al or Cu
	800 A	(4) 3/0–750 kcmil Al or Cu	(3) 3/0–500 kcmil Al or Cu or two 3/0–750 kcmil Al or Cu
	1200 A	(4) 3/0–750 kcmil Al or Cu	(4) 3/0–500 kcmil Al or Cu or (4) 3/0–750 kcmil Al or Cu
	1600 A	VCEL compression lugs Standard.	

Standard Mechanical Lugs—Main Switch

Panel Type	Mains Ampere Rating	Lug Wire Range ▲	Wire Range Wire Bending Space per CSA ▲
QMB	200 A	#4–300 kcmil Al or Cu	one #4–300 kcmil Al or Cu
	400 A	3/0–600 kcmil Al or Cu	two 3/0–600 kcmil Al or Cu
	600 A	3/0–600 kcmil Al or Cu	two 3/0–600 kcmil Al or Cu
	800 A	3/0–600 kcmil Al or Cu	(3) 3/0–500 kcmil Al or Cu

Standard Mechanical Lugs—QMB Branch Switch Units

Panel Type	Switch Ampere Rating	Lug Wire Range ▲	Wire Range Wire Bending Space per CSA ▲
QMB	30 A	one #14–#2 Al or Cu	one #14–#2 Al or Cu
	60 A	one #14–#2 Al or Cu	one #14–#2 Al or Cu
	100 A	one #14–1/0 Al or Cu	one #14–1/0 Al or Cu
	200 A	one #4–300 kcmil Al or Cu	one #4–300 kcmil Al or Cu
	400 A	two 3/0–600 kcmil Al or Cu	two 3/0–500 kcmil Al or Cu
	600 A	two 3/0–600 kcmil Al or Cu	two 3/0–500 kcmil Al or Cu
	800 A	(3) 3/0–600 kcmil Al or Cu	(3) 3/0–500 kcmil Al or Cu

Standard Mechanical Lugs—QMJ Branch Switch Units ■

Panel Type	Switch Ampere Rating	Lug Wire Range ▲	Wire Range Wire Bending Space per CSA ▲
QMJ	30 A	one #14–#2 Al or Cu	one #14–#2 Al or Cu
	60 A	one #14–#2 Al or Cu	one #14–#2 Al or Cu
	100 A	one #14–1/0 Al or Cu	one #14–1/0 Al or Cu
	200 A	one #6–300 kcmil Al or Cu	one #6–300 kcmil Al or Cu
	400 A	one 1/0–750 kcmil Al or Cu	one 1/0–750 kcmil Al or Cu
	400 A	two 1/0–300 kcmil Al or Cu	two 1/0–300 kcmil Al or Cu
	600 A	two 3/0–600 kcmil Al or Cu	two 3/0–600 kcmil Al or Cu

- ▲ (#) = Number of conductors per phase.
- Use only 90 °C insulated conductors based on an ampacity of 75 °C conductors.

DE5 PANELBOARDS

NQ, NF, I-Line, QMB Panelboards

Special Features For Factory Assembled Panels

General Instructions

The special feature options covered in this section are applicable to factory-assembled panelboards only.

Special features are listed in three major categories:

- Mains
- Branches
- Cabinets

Ordering Instructions

Certain features already appear in the Q2C or EQM panelboard quotation system and they are flagged appropriately (▲). For those features not listed on the quotation system, enter the information as it appears in this publication in the "Other Special Features" screen in Q2C or EQM.

Please contact your local Schneider Electric sales office for pricing.

Metric Conversion

Inches (in) x 25.4 = millimeters (mm).

If you have any questions, please contact your local Schneider Electric sales office, or our Customer Information Centre at 1-800-565-6699.

Metering - Type 1 Enclosures Only. (1200 A Maximum)

Boxes and Interiors are shipped fully assembled.

NQ, NF and POWERLINK® require a 7" left side gutter extension and a 6" main end extension for POWERLOGIC Power Meter applications.

I-LINE and QMB require a 14" side gutter extension for POWERLOGIC Circuit Monitor and Power Meter applications.

Current Transformers In Mains (ac only and line side only)▲

Default selection based on transformers having a 5 Ampere secondary and mounted under a separate cover.

Primary Amperes (5 A—Secondary)	Additional Box Height Required ■
100–1200	6"

Customer Equipment Space (end user must specify end use equipment to be installed)▲

Available with NQ and NF lighting panelboards only and must be opposite the mains end, both main breaker and main lug, to prevent interference with incoming cables. Customer equipment space is not available with thru-feed lugs or sub-feed breakers.

A barrier exists between the equipment space and the panelboard compartment; a separate door is provided as standard (requires 18" additional box height).

- ▲ Feature supported by Product selectors in Q2C and EQM.
- For NQ and NF panelboards.

Keyed Interlock

Not available for use in NQ, NF, I-LINE. Not available on I-Line™ with door when key interlock MG/MJ/P/R/ frame branch mounted circuit breakers are installed. Must use 4-piece trim or NEMA 3R/12.

Keyed mechanical interlocking of two or more circuits is available on request. Individual locks are furnished for each circuit. All locks operate by one key, which can be removed only when the circuit is locked in the desired position.

I-LINE Circuit Breakers—A 3" filler adjacent to the circuit is necessary for mounting the interlock; contact your local Schneider Electric sales office for assistance with power distribution panelboards with doors. Feature not available on vertically mounted main circuit breaker.

QMB Fusible Switches—Available on 100A singles▲ thru 800A switches plus LA circuit breaker adapters. Requires 3" of branch mounting space per switch for interlock installation.

- ▲ 100 A single QMB requires 9" of mounting space.

Motor Operators—I-LINE Circuit Breakers Only

Motor operators provide remote *open*, *close*, and *reset* control of molded case circuit breakers.

Legacy F-, L-Frame Circuit Breakers:

- Motor operators require 4.5" of circuit breaker mounting space. This can be provided on I-LINE main circuit breaker only when the main is branch-mounted and back-fed.

PowerPact H-, J-, P-Frame Circuit Breakers:

- motor operators must be factory installed.
- can not be mounted in I-Line panel with a door.

Type Circuit Breaker	Motor operator voltage
FA, FH	120 Vac
LA, LH	120 Vac
H-Frame (3P), J-Frame, P-Frame	48/60, 110/130, 208/277, 380/480 Vac; 24/30, 48/60, 110/130, 250 Vdc

NQ, NF, I-Line, QMB Panelboards

Special Features for Factory Assembled Panels - Mains

Enclosure Modifications

Increased Box Depth (Type MH or HC26 enclosures only)

Type 1 Enclosure — 8" depth (HC26 only)▲
12" depth (HC32, 42, 44—12" only)▲

Type 3R, 5, or 12 Enclosure 8" or 12" depth increments▲

Note: No other depths available.

Increased Side Gutters (Type 1 Enclosures Only)

Note: Available on MH enclosures, (right or left) in 3, 6 and 12-inch added width, 26" wide HC enclosures up to a maximum of 14 additional inches and 32" wide HC enclosures up to a maximum of 10 additional inches. Not available on 42" wide HC enclosures. **No barrier will be supplied unless specified.** Includes one piece trim.

Steel barrier in enclosure

Note: The box will be extended on one side only. If extension is required on both sides, contact your local Schneider Electric sales office for assistance.

Extended Top and Bottom End Gutters (Type 1 Enclosures Only)

Type MH enclosures — 6", 12", 18" or 24" extension, includes one piece trim.▲

Type HCM enclosures — 9" extension, includes trim and extension cover.▲

Type HCP, HCR-U- enclosures — 12" extension, includes trim and extension cover.▲

Type QMB enclosures — 38" W x 11.5" D may have a 6" increased end gutter maximum.

This is the only QMB enclosure with an increased end gutter option and is only available with a 4-piece trim.

For lengths other than listed above, refer to the Wireway section.

▲Feature supported by Product selectors in Q2C and EQM.

Drip Hood▲

For each surface mounted only panelboard.

Finishes — Standard

The standard finish of the enclosure trims is ANSI 49. The boxes are galvanized steel. Options are as follows:

ANSI 49 enclosure.▲

ANSI 61 trim or enclosure.▲

Enclosure other than ANSI 49 or ANSI 61▲

Trim and enclosure with polyester acrylic powder paint finish (provides increased salt spray performance in coastal areas and increased resistance to UV fading).

Special or custom paint for trim and/or box is available.

Free-standing Enclosures

Supports extending out front and back, welded to bottom of enclosure▲

Stainless Steel Trim Fronts

NQ 20" Wide Flush and Surface▲

NF Flush and Surface▲

I-LINE HCM—Standard Trim with Door▲

I-LINE HCP—Standard Trim with Door▲

▲ Feature supported by Product Selectors in Q2C and EQM.

NQ, NF, I-Line, QMB Panelboards

Special Features for Factory Assembled Panels - Cabinets

Padlock Hasp

Hasp, staple and standard lock (padlock not included).

Special Locks

Special locks: Corbin 60, Corbin 15767, Yale 511S, GE 75 or Best 7L7RL3. On trim with 3-point latch, special locks will be installed as a secondary latch. (standard key change).▲

All other locks — contact your local Schneider Electric sales office for assistance.

Quarter turn fasteners.

Note: Special locks for all HC trims and NF panelboards with three-point latches, will be installed as secondary locks. Special locks are not available on I-LINE 42" and 44" wide panelboards or QMB type panelboards.

Note: Many key configurations can be accommodated with our standard Square D lock. Contact your local Schneider Electric sales office for assistance.

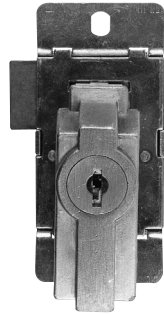

Corbin 15767 Lock

Multi-section Panels

Equal height enclosures.

NQ or NF.▲

I-LINE or QMB.

Common trim in place of two individual fronts (to cover two equal height enclosures mounted side-by-side); available on MH non-hinged trims only.

Sheared on inside edges, allowing boxes to be butted together.

▲ Feature supported by Product selectors in Q2C and EQM.

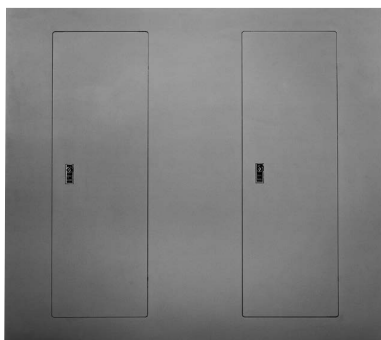

Common Trim Front for Use with Multiple-Section Panelboards Mounted Side-By-Side

NQ, NF, I-Line, QMB Panelboards

Special Features for Factory Assembled Panels - Cabinets

Panel Skirt for Standard Width Panelboards▲

Panel skirts are intended for cosmetic purposes only; they are meant to hide cables which are **enclosed in conduit**. Do not use a panel skirt as a wireway. (For wireway, see below.)

Skirt Length	NQ, NF	I-LINE, QMB
	4" to 60"	X
61" to 92"	X	X

Note: Panel skirts are for Type 1 surface mounted applications with standard depth and width, **Square D enclosures only.**



Panel Skirt Framework To Be Bolted To The Wall

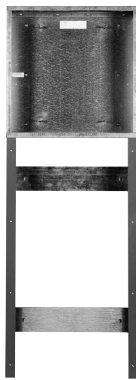

Panel Skirt Bolted In Place Below An MH20 Enclosure



Panel Skirt Completely Installed

Wireway▲

Allows for terminating conduit in the wireway endwall. Only the cable passes through the wireway into the panelboard enclosure. Includes trim and wireway cover.

Wireway Length	NQ, NF	I-LINE, QMB
	4" to 60"	X
61" to 92"	X	X

Note: Wireway is for Type 1, surface mounted applications, with standard depth and width, **Square D enclosures only.**

▲Feature supported by Product Selectors in Q2C and EQM.

DE5 PANELBOARDS

NQ, NF, I-Line, QMB Panelboards

Special Features for Factory Assembled Panels - Cabinets

Panels to Fit Existing Enclosures

Panelboard interiors and special fronts can be furnished to fit existing enclosures.

Use the Retrofit Existing Enclosure data sheet where pertinent dimensions can be recorded. Photocopy the page, then list required dimensions on the photocopy and forward, with the order, to your local Schneider Electric sales office. For interiors requiring vented enclosures, contact your local Schneider Electric sales office for assistance.

Note: Existing enclosure depth on flush installations must be measured from inside surface of box to outer wall or plaster surface.

Special Fronts

Existing enclosure same depth or deeper than our standard, also has the option of special trim.

Note: Elevating brackets to be supplied by customer for existing boxes deeper than our standard.

Existing enclosure shallower than our standard; requires a box extension (surface applications) or a formed trim (flush applications); hinged trim front option is not available for these applications.

Note: Formed trim available on NQ (225 A max) and NF (250 A max). When flush trim is required for an existing enclosure that is shallower than our standard, be sure to indicate the position of the enclosure with respect to the wall in which it is mounted. This is required in order to determine whether a enclosure extension with flat trim should be supplied, or whether a flush formed trim is more applicable. **The interior must be centered in the enclosure** and, if the box is deeper than our standard, the interior must be leveled within the box. **The enclosure must be at least 1.5" longer than the deadfront (interior trim) on each end.** Special trims that are manufactured to fit an existing enclosure will be within $\pm 0.25"$ of the specification. Refer to the table below for standard box depths and for maximum depth for which no special mounting brackets are required.

Panelboard Type	Standard Box Depth	Maximum Box Depth for which No Special Mounting Brackets Required
NQ standard width—main lugs only	5.75"	5.75"
NQ standard width—main circuit breaker	5.75"	5.75"
NF	5.75"	5.75"
I-LINE—Maximum F, H or Q-frame branch circuit breaker	6.5"	7.25"
I-LINE—Maximum J-Frame branch circuit breaker	8.25"	9.0"
I-LINE—Maximum P or R-Frame branch circuit breaker	9.25"	10.25"

Space Heater

Note: Enclosure, interior, and trim ship fully assembled. 120 volt is standard. Top feed applications only.

NQ and NF require 18 inches equipment space in NEMA 3R/12 constructions. NQ and NF require 6 inch bottom end gutter in NEMA 1 construction.

Unwired (provisions for wiring to external source).

Wired (with overcurrent device, thermostat).

NQ, NF, I-Line, QMB Panelboards

Retrofit Existing Enclosure Data

Data Sheet for Panelboards to Retrofit Existing Enclosures

Distributor: _____

Job Name: _____

Contractor: _____

Panel Marking: _____

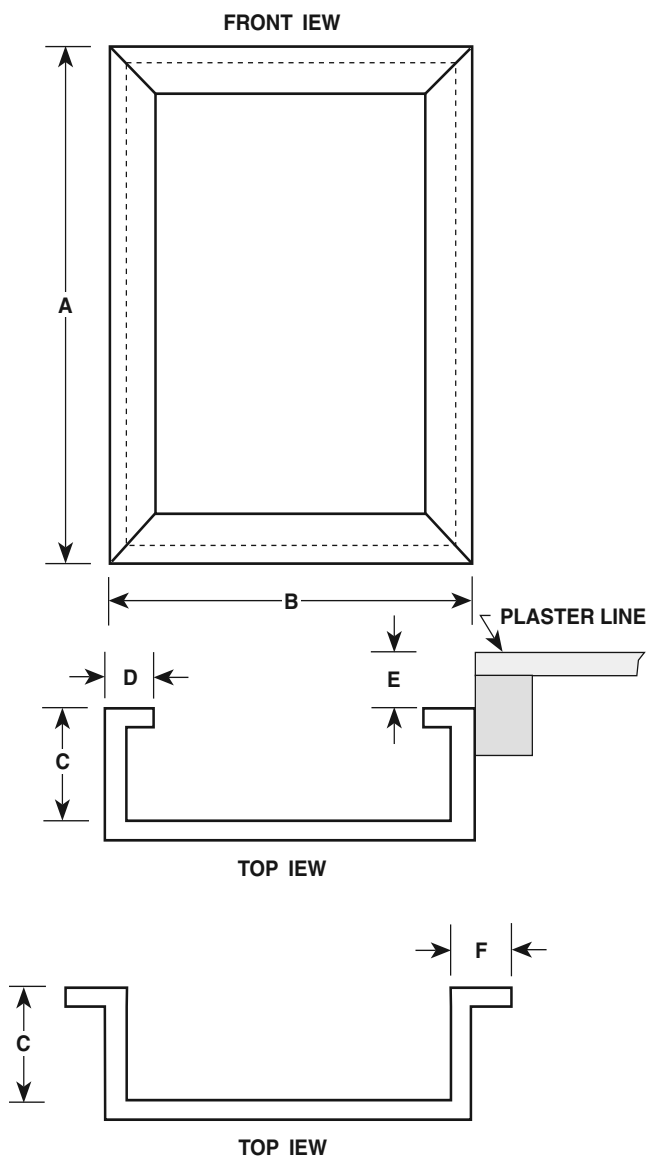

The following dimensions are necessary for quotation and production of a panel to fit an existing box (provide dimensions in inches only):

1. Existing Flush-Mounted Boxes

Height dimension "A":

Width dimension "B":

Depth dimension "C":

Flange width dimension "D":

If box is not flush with Plaster Line, dimension "E":

2. Existing Surface-Mounted Boxes

Height dimension "A":

Width dimension "B":

Depth dimension "C":

Flange dimension may be either dimension "D" or "F" (select one)

a. Dimension "D":

b. Dimension "F":

Note: Trims are furnished so that the interior must be centered within the box. If the box is deeper than the standard panelboard box for the required type of panelboard, *customer supplied mounting brackets may be necessary to bring the interior out to the front of the box.* If interior requires a vented enclosure, contact your local Schneider Electric sales office for assistance.

NQ, NF, I-Line, QMB Panelboards

Special Features for Factory Assembled Panels - Cabinets

Special Enclosures▲

Type 1 gasketed enclosure (gasketing between trim and enclosure)

Note: For 250 A and below enclosures with doors only.

Stainless steel enclosure—Type 3R-12

NQ and NF
I-LINE ★
QMB ◆

Note: #316 stainless steel is available, contact your local Schneider Electric sales office for pricing information.

Fiberglass enclosures—Type 4X Non-Vented

NQ† and NF *
I-LINE and QMB Not Available

Type 12 Door-In-Door enclosures. See Table Below



I-Line door in door enclosure

Interior Type	Enclosure Size		
	Height	Width	Depth
NQ†	56"	20"	6.5"
NF *	56"	20"	6.5"
I-LINE (HCM)	91"	32"	11.5"
I-LINE (HCP)	68"	42"	12.7"
I-LINE (HCP)	86"	42"	12.7"

- ▲ Feature supported by Product Selectors in Q2C and EQM.
- ★ Not available for HCR-U interiors.
- ◆ Not available for QMB interiors over 800 amperes.
- † Maximum 225 A for NQ.
- * Maximum 250 A for NF.

Obsolete Panelboards Information

For information on replacement breakers and parts for NBC, NBLP, NBDP, NHC, NHDP and CDP Panelboards, please contact our Customer Information Centre at 1-800-565-6699.

- 240V NBC, NBLP and NBDP panels are replaced by Square D NQ panels.
- 600V NHC panels are replaced by Square D NF panels.
- 600V NHDP panels are replaced by Square D NF panels for 347/600V wye applications and Square D I-Line panels for 600V delta applications.
- 600V CDP panels are replaced by Square D I-Line panels

X-ON Electronics

Largest Supplier of Electrical and Electronic Components

Click to view similar products for [Circuit Breakers](#) category:

Click to view products by [Schneider](#) manufacturer:

Other Similar products are found below :

[M39019/04-249S](#) [M39019/04-313S](#) [M55629/1-001](#) [M55629/1-016](#) [M55629/1-018](#) [M55629/1-021](#) [M55629/1-033](#) [M55629/1-036](#) [M55629/1-046](#) [M55629/1-048](#) [M55629/1-058](#) [M55629/1-060](#) [M55629/1-067](#) [M55629/1-070](#) [M55629/1-079](#) [M55629/1-084](#) [M55629/1-085](#) [M55629/1-101](#) [M55629/1-108](#) [M55629/1-109](#) [M55629/11-102](#) [M55629/1-120](#) [M55629/12-045](#) [M55629/12-046](#) [M55629/1-243](#) [M55629/1-330](#) [M55629/1-331](#) [M55629/1-351](#) [M55629/1-366](#) [M55629/1-387](#) [M55629/1-388](#) [M55629/1-401](#) [M55629/1-430](#) [M55629/1-450](#) [M55629/1-453](#) [M55629/2-022](#) [M55629/2-037](#) [M55629/2-082](#) [M55629/2-099](#) [M55629/2-101](#) [M55629/2-102](#) [M55629/2-115](#) [M55629/2-116](#) [M55629/2-183](#) [M55629/21-HM-HM](#) [M55629/21-NS-NS](#) [M55629/21-SK-UK](#) [M55629/22-NR-NR-NR](#) [M55629/22-RS-RS-RS](#) [M55629/22-TM-TM-TM](#)