

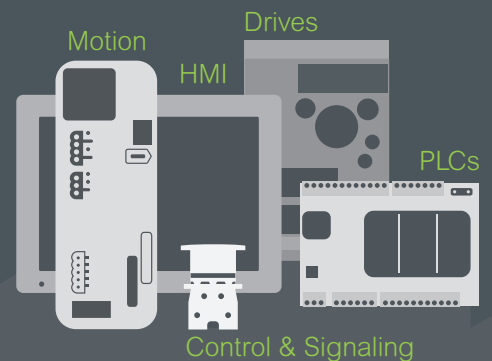

## Introducing the **Easy Series**

Essential automation & control products

*When just enough is just right!*



# Easy Harmony ET6

Human Machine Interfaces  
Essential touch screen panels for  
simple machines

# Contents

## Easy Harmony ET6 Essential touch screen panels

<b>Selection guide</b> .....	<i>page 2</i>
■ <b>General Presentation</b> .....	<i>page 4</i>
■ <b>Presentation and applications</b> .....	<i>page 5</i>
■ <b>Operation</b> .....	<i>page 5</i>
■ <b>Configuration</b> .....	<i>page 5</i>
■ <b>Communication</b> .....	<i>page 5</i>
■ <b>Functions</b> .....	<i>page 6</i>
■ <b>Operating modes</b>	
- Edit mode .....	<i>page 6</i>
- Communication with RS-422/RS-485 serial link mode .....	<i>page 7</i>
- Communication with RS-232C serial link mode .....	<i>page 7</i>
- Communication with Ethernet mode .....	<i>page 7</i>
■ <b>Description</b>	
□ Easy Harmony ET6 SIO model .....	<i>page 8</i>
□ Easy Harmony ET6 ETH model .....	<i>page 8</i>
■ <b>References</b>	
□ Easy Harmony ET6 SIO basic touch screen panels .....	<i>page 9</i>
□ Easy Harmony ET6 ETH universal touch screen panels .....	<i>page 9</i>
□ Configuration software .....	<i>page 9</i>
□ Spare parts .....	<i>page 10</i>
□ Connection accessories .....	<i>page 10</i>
□ Cables for connecting Easy Harmony ET6 panels to Schneider Electric PLCs .....	<i>page 10</i>
□ Cables and adapters for connecting Harmony ET6 panels to third-party PLCs .....	<i>page 11</i>
□ Connecting Harmony ET6 panels via Modbus serial link .....	<i>page 11</i>
■ <b>Product reference index</b> .....	<i>page 12</i>

# Human Machine Interfaces

## Easy Harmony ET6

Essential touch screen panels for simple machines

<b>Applications</b>		Display of text messages, graphic objects, and synoptic views Control and configuration of data	
<b>Type of display module</b>		SIO HMI panels	
			
<b>Display</b>	Touch screen size	7" W	10.1" W
	Resolution (pixels)	800 x 480 pixels, 16 million colors	1,024 x 600 pixels, 16 million colors
	Type	TFT Color LCD, single-touch analog resistive	
<b>Degree of protection</b>		IP65 (front)	
<b>Functions</b>	Brightness control	16 levels (adjusted with touch panel or software)	
	Backlight service life	20,000 hours or more (continuous operation at 25 °C/77 °F) before backlight brightness decreases to 50%	
<b>Memory</b>	Device memory	256 MB	256 MB
	User data memory	256 MB	256 MB
	Backup memory	128 KB NVRAM	
<b>Dimensions</b>	External W × H × D mm/in.	205.5 x 150.5 x 45/8.09 x 5.92 x 1.77	270.5 x 200.5 x 47/10.64 x 7.89 x 1.85
	Cut-out W × H mm/in.	190 x 135/7.48 x 5.31	255 x 185/10.04 x 7.28
<b>Weight</b>	kg/lb	0.600/1.323	0.980/2.161
<b>Supply voltage</b>		19.2 V...28.8 V $\overline{=}$	
<b>Environment</b>		Ambient air temperature 0...50 °C/32...122 °F	
<b>Communication</b>	Asynchronous serial link	RS-232C (COM1), RS-485/RS-422 (COM2)	
	USB ports	1x USB 2.0 Micro-B	
	Buses and networks	No	No
<b>RTC</b>		Yes	
<b>Conformity to standards and certifications</b>		CE, China RoHS, and UL 61010-2-201	
<b>Operating system</b>		VxWorks	
<b>Development software</b>		Vijeo Designer Basic (1)	
<b>Terminal reference</b>		<b>HMIET6401</b>	<b>HMIET6501</b>
<b>Pages</b>		9	

(1) Requires Vijeo Designer Basic V1.2. For more information on Vijeo Designer, please refer to the [DIA5ED2130614EN](#) catalog.

<b>Display of text messages, graphic objects, and synoptic views Control and configuration of data</b>			
ETH HMI panels			
			
7" W	10.1" W	12.1" W	15.6" W
800 x 480 pixels, 16 million colors	1,024 x 600 pixels, 16 million colors	1,280 x 800 pixels, 16 million colors	1,366 x 768 pixels, 16 million colors
TFT Color LCD, single-touch analog resistive			
IP65 (front)		IP65 (front), Type 4X (indoor use only)	
16 levels (adjusted with touch panel or software)			
20,000 hours or more (continuous operation at 25 °C/77 °F) before backlight brightness decreases to 50%			
256 MB	256 MB	256 MB	256 MB
128 KB NVRAM			
205.5 x 150.5 x 45/8.09 x 5.92 x 1.77	270.5 x 200.5 x 47/10.64 x 7.89 x 1.85	310.5 x 232.5 x 50/12.22 x 9.5 x 1.97	412 x 268 x 50/16.22 x 10.55 x 1.97
190 x 135/7.48 x 5.31	255 x 185/10.04 x 7.28	295 x 217/11.61 x 8.54	394 x 250/15.51 x 9.84
0.610/1.344	0.990/2.183	1.620/3.571	2.520/5.556
19.2 V...28.8 V $\overline{=}$			
Ambient air temperature 0...50 °C/32...122 °F			
RS-232C (COM1), RS-485/RS-422 (COM2)			
1x USB 2.0 (Type A), 1x USB 2.0 Micro-B			
1x Ethernet TCP/IP (10BASE-T/100BASE-TX)			
Yes			
CE, China RoHS and UL 61010-2-201			
VxWorks			
Vijeo Designer Basic (1)			
<b>HMIET6400</b>	<b>HMIET6500</b>	<b>HMIET6600</b>	<b>HMIET6700</b>
9			



More technical information on [www.se.com](http://www.se.com)



More technical information on [www.se.com](http://www.se.com)

**Essential touch screen panels for communication with simple machine systems**

Easy Harmony ET6 essential touch screen panels are entry-level products that are tailored to meet the specific requirements of new economies. These panels are designed to communicate with simple machine systems for human machine interaction.



**Better visualization**

Improved graphical presentation of the machine information with:

- Better quality of graphic display with high resolution (over 30% higher than legacy) (1)
- More colorful with 16 million colors

**Better performance**

Improved user operation experience with:

- Faster micro processor unit for operational performance of screen changes, parts animations, and scripts, etc.
- More memory to design higher level applications with HD graphics, charts, recipes, and operation logs (alarm/event/data), etc.

**Easy to use**

- Product information via QR code scanning
- Easily mounted with anti-drop hooks
- Easy migration of legacy panels with compatible installation cut-out, communication ports, and configuration software
- Easy to set up and use with simplified and intuitive programming software (Vijeo Designer Basic) and an illustrated Online help for self-guided training



Anti-drop hooks

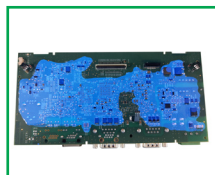

Default coating

**Robustness**

- Designed with isolated power supply and enhanced protection on serial communication port for better EMC performance in harsh industrial environments.
- Designed with protection for reverse power connection against negligent miswiring
- PCBA default coating to be sustainable in harsh environment with high humidity
- USB clamps for stable USB cable connection

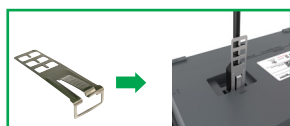

Clamp option for USB Type A



Clamp for USB Type B

(1) Except 7" W panel.



7" Wide and 10" Wide Easy Harmony ET6 touch screen panels

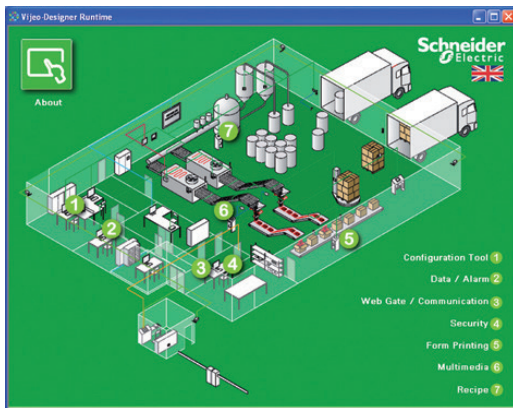

Example of project configuration

### Presentation and applications

The range of Easy Harmony ET6 essential touch screen panels has been designed for various industrial production machines and system integration. They are dedicated to the following fields and types of machine:

- Utilities and engineering equipment
  - Water pump
  - Air conditioning (compressor, heat exchangers, chillers, etc)
  - Mechanical parking system
  - Crane
  - Car washing equipment
  - EV car charging pile
- Production machines
  - Textile machinery (blowing, carding, winding, twisting, etc.)
  - Packaging machinery (VFFS, wrapping, labelling, etc.)
  - Material working (Metal, wood, stone and glass, etc.)
  - Plastic and rubber (foaming, molding, extruding, etc.)
  - Other segments (electronics, SEMICON, Li-battery, printing, etc.)

This range of panels is available with two different models of communication ports:

- ETH model with Ethernet port (7", 10", 12", and 15" wide screen)
- SIO model without Ethernet port (7" and 10" wide screen)

### Operation

Easy Harmony ET6 touch screen panels are designed to meet the essential needs of information and communication technologies, which, depending on the model, include:

- Essential level of communication (serial multilink, USB downloading port)
- High level of communication (embedded Ethernet multilink) (1)
- External data storage (on a USB memory stick) for storing production data and backing up applications (1)
- Management of peripheral equipment: printers, barcode readers, etc. (1)

These panels offer an excellent level of technical performance and are designed for use mainly by OEM customers.

### Configuration

Easy Harmony ET6 touch screen panels are configured using Vijeo Designer Basic software(1) in Windows 7, Windows 8.1, and Windows 10 (32-bit and 64-bit) environments. This simplified configuration software boasts an intuitive user interface with many configurable windows, enabling projects to be developed quickly and easily.

### Communication

Automation platform or logic controller

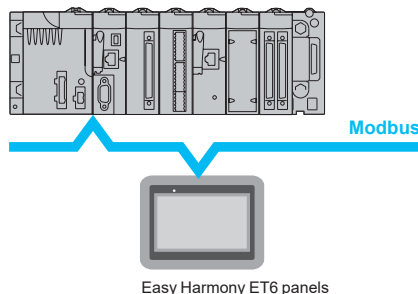

Easy Harmony ET6 touch screen panels can communicate with various PLCs via the integrated serial links or Ethernet links, using the following communication protocols:

- Schneider Electric (Modbus)
- Third-party: Mitsubishi Electric, Omron, and Siemens

(1) Requires Vijeo Designer Basic version 1.2

### Functions

Easy Harmony ET6 touch screen panels with Vijeo Designer Basic offer the following functions:

- Display of animated mimics with 8 types of animation (pressing the touch panel, color changes, filling, movement, rotation, size, visibility, and value display)
- Control, modification of numeric and alphanumeric values
- Display of date and time
- Real-time curves and trend curves with log
- Alarm display, alarm log, and management of alarm groups
- Multi-window management
- Page calls initiated by the operator
- Multilingual application management (10 languages simultaneously)
- Recipe management
- Data processing via Java Script
- Application and logs stored on external application memory card in USB stick format
- Management of printer and barcode reader

### Operating modes for Harmony ET6 touch screen panels

#### Edit mode

Easy Harmony ET6 panel

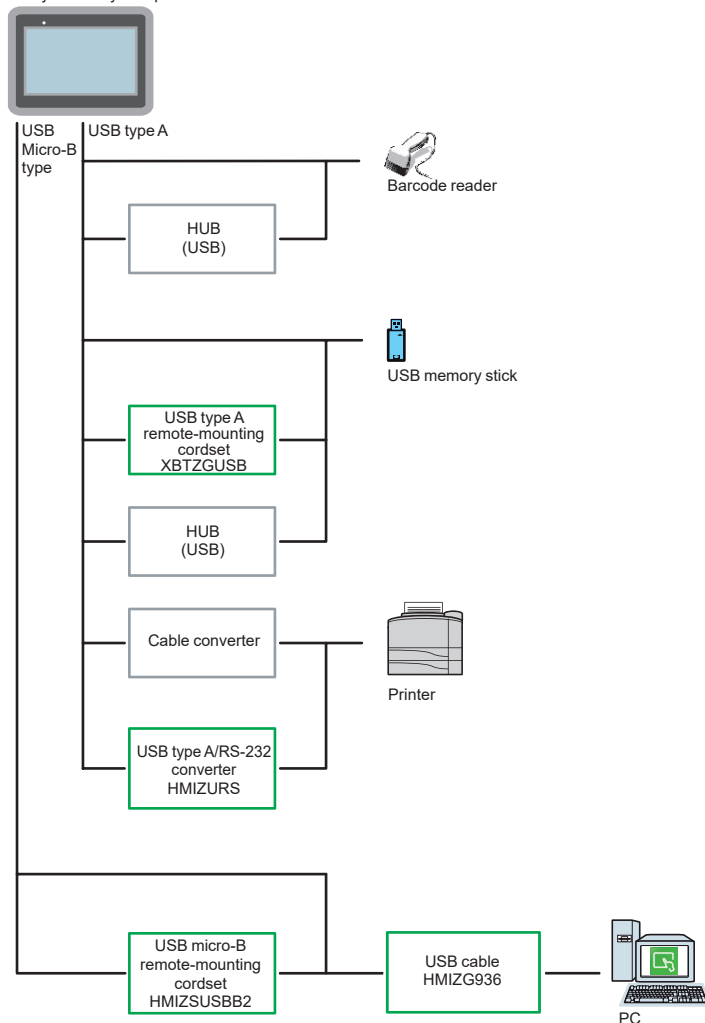

### Operating modes for Harmony ET6 touch screen panels (continued)

#### Communication with RS-422/RS-485 serial link mode

Easy Harmony ET6 panels

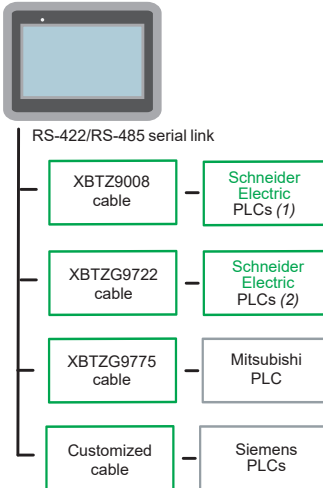

Examples of connection to RS-422/RS-485 serial port (3)

#### Communication with RS-232C serial link mode

Easy Harmony ET6 panels

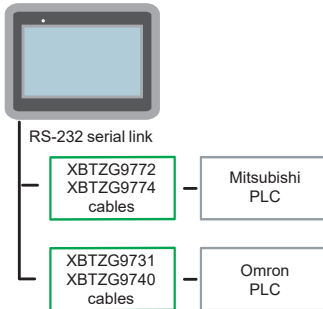

Examples of connection to RS-232C (3)

#### Communication with Ethernet mode

Easy Harmony ET6 panels

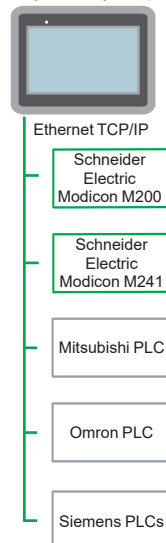

(1) M221/M241/M251/M218/M258 logic controllers.  
 (2) M100/M200 logic controllers. For all other products, contact our Customer Care Center.  
 (3) Non-exhaustive examples; contact our Customer Care Center for more information.

## Human Machine Interfaces

### Easy Harmony ET6

Essential touch screen panels for simple machines

ETH and SIO touch screen panels

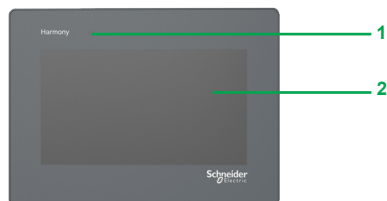

Front view



Rear view

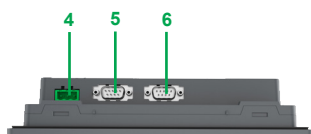

Underside view

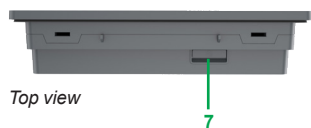

Top view



Front view



Rear view

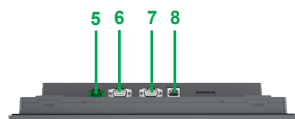

Underside view



Top view

### Easy Harmony ET6 SIO touch screen panels

#### Front view

- 1 An LED on/off indicator
- 2 Wide, true color LCD and touch screen

#### Rear view

- 3 USB micro-B port for screen data downloading

#### Underside view

- 4 A 24 V DC power supply connector supplied with the terminal
- 5 A 9-way male SUB-D connector for RS 232C serial link (COM1 port)
- 6 A 9-way male SUB-D connector for RS 422/RS 485 serial link (COM2 port)

#### Top view

- 7 A sliding slot containing a replaceable battery to support embedded real-time clock

### Easy Harmony ET6 ETH touch screen panels

#### Front view

- 1 An LED on/off indicator
- 2 Wide, true color LCD and touch screen

#### Rear view

- 3 A USB type A port for external storage with USB memory stick
- 4 A USB micro-B port for screen data downloading

#### Underside view

- 5 A 24 V DC power supply connector supplied with the terminal
- 6 A 9-way male SUB-D connector for RS-422/RS-485 serial link (COM2 port)
- 7 A 9-way male SUB-D connector for RS-232C serial link (COM1 port)
- 8 An Ethernet port, 10/100Base-Tx type



# Human Machine Interfaces

## Easy Harmony ET6

Essential touch screen panels for simple machines

ETH and SIO touch screen panels and Vijeo Designer software



HMIET6501



HMIET6700



Vijeo Designer Basic

### Easy Harmony ET6 SIO touch screen panels (1) (2)

Screen size and type	Number of ports	Memory capacity		Reference	Weight kg/lb
		For application	For backup		
7" wide, 800 x 480 pixels, color TFT screen	1x COM2 (RS-422/485), 1x COM1 (RS-232C), 1x USB micro-B	256 MB	128 KB	<a href="#">HMIET6401</a>	0.60/1.32
10" wide, 1,024 x 600 pixels, color TFT screen				<a href="#">HMIET6501</a>	0.98/2.16

### Easy Harmony ET6 ETH touch screen panels (1) (2)

Screen size and type	Number of ports	Memory capacity		Reference	Weight kg/lb
		For application	For backup		
7" wide, 800 x 480 pixels, color TFT screen	1x COM1 (RS-232C), 1x COM2 (RS-422/485)	256 MB	128 KB	<a href="#">HMIET6400</a>	0.61/1.34
10" wide, 1,024 x 600 pixels, color TFT screen	1x USB micro-B, 1x USB Type A, 1x 10/100 Base-Tx			<a href="#">HMIET6500</a>	0.99/2.18
12" wide, 1,280 x 800 pixels, color TFT screen				<a href="#">HMIET6600</a>	1.62/3.57
15.6" wide, 1,366 x 768 pixels, color TFT screen				<a href="#">HMIET6700</a>	2.52/5.56

### Configuration software

Description	Used for	Reference
Vijeo Designer Basic (4)	Easy Harmony ET6 models	(3)

(1) Panels supplied with fixing screws, power supply connector, and instruction sheet. Setup documentation for Easy Harmony ET6 panels is included in electronic format with the Vijeo Designer Basic configuration software.

(2) Comprehensive information relating to Easy Harmony ET6 panels is available on our website.

(3) To download this software, visit our website [www.se.com](http://www.se.com).

(4) Requires software version 1.2. Cable for transferring application from PC to Easy Harmony ET6 panels (HMIZG936), to be ordered separately (see our website [www.se.com](http://www.se.com)).

# Human Machine Interfaces

## Easy Harmony ET6

Essential touch screen panels for simple machines

### Spare parts and connection accessories

PF143710B



HMIZGFIX3

ET6\_30834661\_OPSPH21004



HMIZSFIXTF1

ET6\_30834661\_OPSPH21006



HMIZGPWS1

ET6\_30834661\_OPSPH21003



HMIZGCLP1

ET6\_30834661\_OPSPH21001



HMIZSCLP3

ET6\_30834661\_OPSPH21002



HMIZSUSBB2

ET6\_30834661\_OPSPH21005



HMIZG936

#### Spare parts

Description	Used for	Sold in lots of	Reference	Weight kg/lb
Installation fastener	Used to install 7", 10", and 12" wide model into the solid panel	24 pieces/set	HMIZGFIX3	–
	Used to install 15.6" wide model into a solid panel	2 pieces/set	HMIZSFIXTF1	–
DC power supply connector	Connector for a DC power supply cable	5 pieces/set	HMIZGPWS1	–
Replacement battery	Primary battery for time data backup (RTC)	1 piece/set	HMIZSBA1	–
USB clamp Type A (for 1 port)	Clamp to prevent disconnection of USB cable	5 pieces/set	HMIZGCLP1	–
USB clamp mini-B/micro-B (for 1 port)	Clamp to prevent disconnection of USB cable	5 pieces/set	HMIZSCLP3	–
Screen protection sheet, disposable, dirt-resistant, and ultra-violet protected	Protection sheet for 7" wide screen	1 piece/set	HMIZG63W	–
	Protection sheet for 10" wide screen	1 piece/set	HMIZG65W1	–
	Protection sheet for 12" wide screen	1 piece/set	HMIZUV6W	–
	Protection sheet for 15.6" wide screen	1 piece/set	HMIZG67W	–

#### Connection accessories

Designation	Description	Length m/ft	Reference	Weight kg/lb
USB (micro-B) front cable	Extension cable that attaches USB interface to HMI front panel	1.8/5.91	HMIZSUSBB2	0.230/0.507
USB (Type A) front cable	Extension cable that attaches USB interface to front panel	1/3.28	XBTZGUSB	0.507/1.118
USB transfer cable	Cable for transferring screen data from a PC (USB Type A) to HMI (USB micro-B)	1/3.28	HMIZG936	0.100/0.220
USB Type A port/9-way SUB-D converter for serial printer	Enables connection of an RS 232 serial link printer (9-way SUB-D) to the USB Type A port of Easy Harmony ET6 Ethernet panels	–	HMIZURS	–

### Cables for connecting Easy Harmony ET6 panels to Schneider Electric PLCs

Type of automation product	Type of connector (automation product end)	Protocol	Type of Easy Harmony ET6 panels	Physical link (panels port)	Length m/ft	Reference	Weight kg/lb
Modicon M340 Modicon M218 Modicon M258 Modicon M221 Modicon M241 Modicon M251	RJ45	Modbus	All models	RS-485	2.5/8.20	<a href="#">XBTZ9008</a>	–
Easy Modicon M100 Easy Modicon M200	Terminal block	Modbus	All models	RS-485	2.5/8.20	<a href="#">XBTZG9722</a>	–
TeSys U/T starters Altivar drives Altistart starters Lexium motion control Preventa XPS MC	RJ45	Modbus	All models	RS-485	2.5/8.20	<a href="#">XBTZ9008</a>	–

### Cables and adapters for connecting Easy Harmony ET6 panels to third-party PLCs

Description Driver used	Type of Easy Harmony ET6 panels	Type of connector (fitted to cable, excluding adapter)	Physical link (panels port)	Length m/ft	Reference	Weight kg/lb
<b>Mitsubishi, Melsec PLCs</b>						
Connection cable, Q Link (SIO)	All models	9-way SUB-D/9-way SUB-D	RS-232C	5/16.40	<a href="#">XBTZG9772</a>	–
Connection cable, Q CPU (SIO)	All models	9-way SUB-D/mini-DIN	RS-232C	5/16.40	<a href="#">XBTZG9774</a>	–
Connection cable, FX (CPU)	All models	9-way SUB-D/mini-DIN	RS-422	5/16.40	<a href="#">XBTZG9775</a>	–
<b>Omron, Sysmac PLCs</b>						
Connection cables, Link (SIO)	All models	9-way SUB-D/25-way SUB-D	RS-232C	5/16.40	<a href="#">XBTZG9731</a>	–
	All models	9-way SUB-D/9-way SUB-D	RS-232C	5/16.40	<a href="#">XBTZG9740</a>	–
Connection cable, FINS (SIO)	All models	9-way SUB-D/9-way SUB-D	RS-232C	5/16.40	<a href="#">XBTZG9740</a>	–
<b>Siemens, Simatic PLCs</b>						
Connection cables, MPI port, S7 200, S7 300/400	All models	9-way SUB-D/9-way SUB-D	RS - 485	–	(1)	–
<b>Customizable cables</b>						
Universal cable, RS-422	All models	9-way SUB-D/flying leads at other end	RS-422	2.5/8.20	<a href="#">XBTZG9722</a>	–

### Connecting Easy Harmony ET6 panels via Modbus serial link

Type of bus/network	Tap-off units	Connector (tap-off unit end)	Type of Easy Harmony ET6 panels	Length m/ft	Reference	Weight kg/lb
Modbus serial link	8-port Modbus splitter box <a href="#">LU9GC3</a> 2-port tap junction <a href="#">TWDXCAISO</a> <a href="#">TWDXCAT3RJ</a>	RJ45	All models	2.5/8.20	<a href="#">XBTZ9008</a>	–

(1) Customized cable.

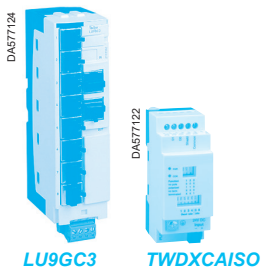

---

H	
HMIET6400	9
HMIET6401	9
HMIET6500	9
HMIET6501	9
HMIET6600	9
HMIET6700	9
HMIZG63W	10
HMIZG65W1	10
HMIZG67W	10
HMIZG936	10
HMIZGCLP1	10
HMIZGFIX3	10
HMIZGPWS1	10
HMIZSBA1	10
HMIZSCLP3	10
HMIZSFIXTF1	10
HMIZSUSBB2	10
HMIZURS	10
HMIZUV6W	10
X	
XBTZ9008	11
XBTZG9722	11
XBTZG9731	11
XBTZG9740	11
XBTZG9772	11
XBTZG9774	11
XBTZG9775	11
XBTZGUSB	10

Life Is On



Learn more about our products at  
[www.se.com](http://www.se.com)

The information provided in this documentation contains general descriptions and/or technical characteristics of the performance of the products contained herein. This documentation is not intended as a substitute for and is not to be used for determining suitability or reliability of these products for specific user applications. It is the duty of any such user or integrator to perform the appropriate and complete risk analysis, evaluation and testing of the products with respect to the relevant specific application or use thereof. Neither Schneider Electric nor any of its affiliates or subsidiaries shall be responsible or liable for misuse of the information contained herein.

Design: Schneider Electric  
Photos: Schneider Electric

**Schneider Electric Industries SAS**

Head Office  
35, rue Joseph Monier - CS 30323  
F-92500 Rueil-Malmaison Cedex  
France

DIA5ED2210601EN  
June 2021 - V1.0

## X-ON Electronics

Largest Supplier of Electrical and Electronic Components

*Click to view similar products for [USB Cables / IEEE 1394 Cables](#) category:*

*Click to view products by [Schneider](#) manufacturer:*

Other Similar products are found below :

[88764-0800](#) [148700-1](#) [AC102012-1](#) [AC102012-2](#) [45-1345-15](#) [45-1358-15](#) [45-1363-15](#) [IP-USB1\(C10\)S-RW](#) [CABLE/RTP/USB/DT](#) [45-1351-15](#) [45-1357-15](#) [45-1433-1](#) [10115240-12200LF](#) [687680278](#) [MDM9PH004P](#) [FTP-629Y401](#) [FTP-628Y402](#) [UPMAB-1M](#) [CSMNB9MF-5](#) [UA-30AMFM-SL7B03](#) [UES-1001A160](#) [UES-1003A160](#) [USBCAMCM100](#) [USB A/F\\*2 to 2.54 2\\*5P-SH L=400mm](#) [103-1020-BL-00100](#) [103-1030-BL-F0300](#) [103-1092-BL-F0200](#) [105-1092-BL-00300](#) [105-1092-BL-00200](#) [105-1031-BL-00200](#) [105-1032-RE-B0200](#) [103-1020-BL-00300](#) [103-1020-BL-00200](#) [9370-P](#) [9372-0-15-01-13-14-10-0](#) [USBFTV2SA2G10OPEN](#) [103-1030-BL-F0200](#) [105-1032-RE-B0100](#) [105-1032-RE-B0050](#) [105-1032-SV-B0200](#) [10-00003](#) [KUCA1](#) [USBF21GSCC](#) [3004-235](#) [UA20FL-UAFL-SA002](#) [NUB-20AMFM-SL7A03](#) [UA-20AFMM-LR7A04](#) [Kit30394NI](#) [CABLE-IP-USB-5M](#) [PX0418/2M00](#)