



MAIN CATALOG

24TH EDITION



Schroff® MAIN CATALOG

EQUIPMENT PROTECTION SOLUTIONS

24TH EDITION | OCTOBER 2012

06 Subracks / 19" chassis



SCHROFF GMBH, LANGENALBER STRASSE 96-100, D-75334 STRAUBENHARDT WWW.PENTAIREQUIPMENTPROTECTION.COM

39601-641 © 2012 Pentair Equipment Protection

Subracks/19" chassis

europac PRO

19" subrack with high flexibility
in accordance with IEC 60297-3-103 and IEEE 1101.10/11

For different applications:

- Kits, individual configuration and an extensive accessory range
- Industrial applications
- Shock and vibration resistance up to 5 g, e.g. for mobile railway applications
- Shock and vibration resistance up to 25 g for rugged environments, e.g. mobile military applications



36106005 06109001 06108006 06112002 06112020

Overview 0

Cabinets 1

Wall mounted cases 2

Accessories for cabinets and wall mounted cases 3

Climate control 4

Desk-top cases 5

Subracks/ 19" chassis ... 6

Front panels, plug-in units .. 7

Systems 8

Power supply units 9

Backplanes .. 10

Connectors, front panel component system 11

Appendix 12

Subracks/19" chassis

multipacPRO

19" chassis for non-standard components and horizontal board construction
Versions in aluminium and steel plate (AlZn coated)
Kits from stock or to individual configuration

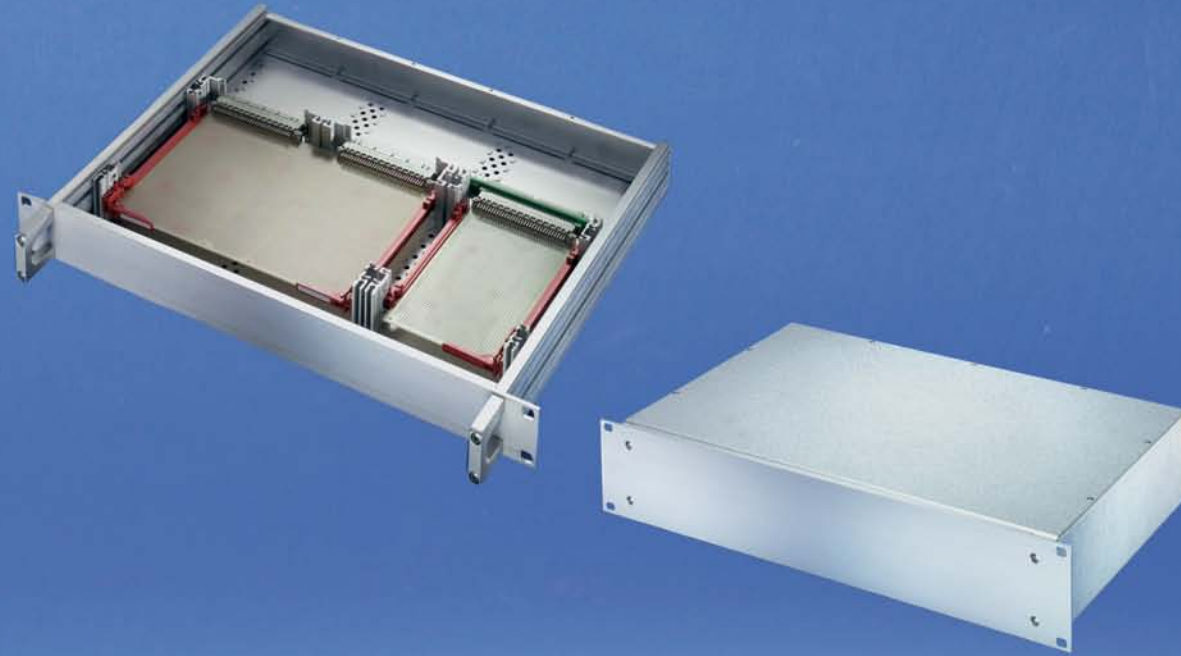

inpac

19" chassis with high mechanical stability
Flexible construction for standard board formats or individual solutions
Can be used as a desk-top enclosure

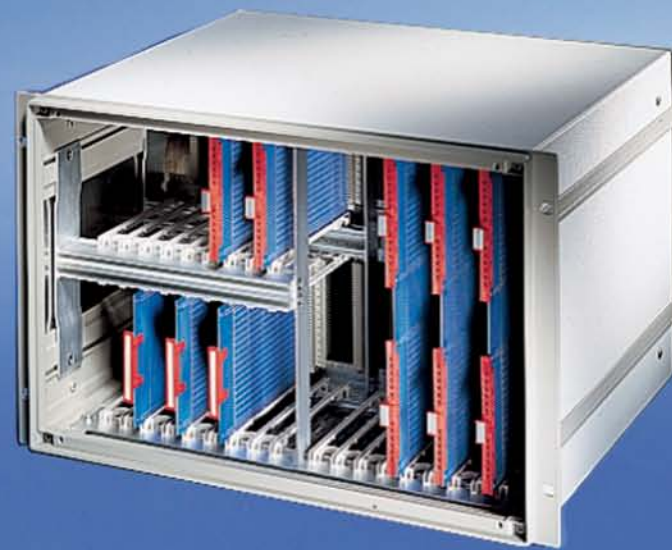

Overview 6.0

europacPRO . . 6.2

multipac 6.112

inpac 6.128

Application examples
europacPRO . . 6.69
Subracks for
mobile railway
applications . . 6.70
multipac 6.112

Overview 0

Cabinets 1

Wall mounted cases 2

Accessories for cabinets and wall mounted cases 3

Climate control 4

Desk-top cases 5

Subracks/ 19" chassis ... 6

Front panels, plug-in units .. 7

Systems 8

Power supply units 9

Backplanes .. 10

Connectors, front panel component system 11

Appendix 12

Subracks - **europacPRO**



- europacPRO standard**
- 19" subrack with high flexibility
 - EMC shielding upgradable
 - In accordance with IEC 60297-3-103 and IEEE 1101.10/11
 - Kit from stock or individual configuration

europacPRO for mobile railway applications

- Over and above the europacPRO standard range additional shock and vibration properties for up to 5 g in accordance with the standards:
 - IEC 61587-1, EN 50155
 - BN 411002 and BN 411003
 - NF F 61-005 / NF F 60-002

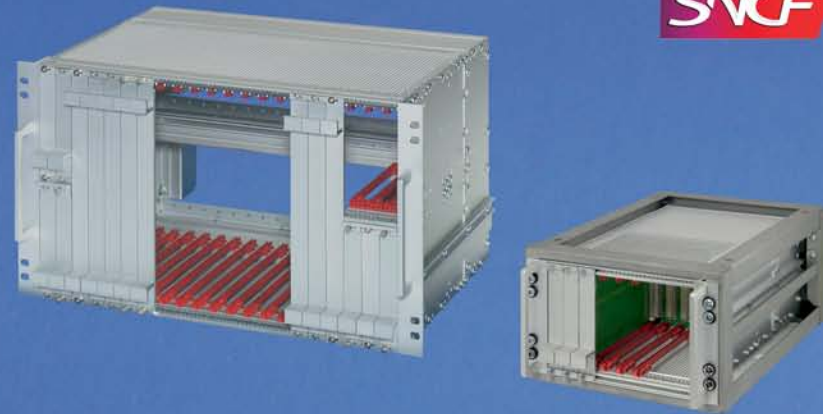

36112001 06109001 06103001 06108006

europacPRO for industrial applications

- Over and above the europacPRO standard range additional kits for wall mounting or for installation of supply modules to DIN 43880



europacPRO for rugged applications

- Over and above the europacPRO standard range additional shock and vibration properties for up to 25 g in accordance with the standards: MIL 167, IEC 61587 DL 3, MIL 810 G, MIL 901

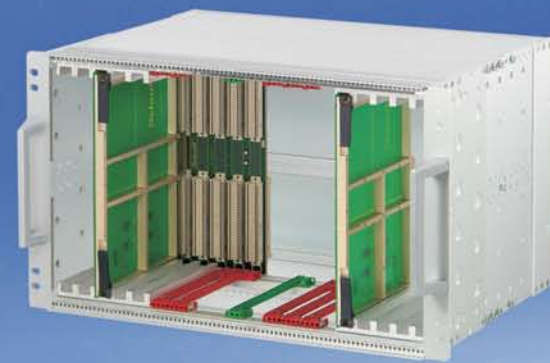

europacPRO accessories

- Extensive range of accessories for europacPRO products
- Side panels, horizontal rails, guide rails, cover plates, front/rear covers, handles and shielding components
- Interior assembly: combined mounting 6 or 2 x 3 U, horizontal board mounting, mounting plates, panel mounting, central locking, telescopic slides, divider plates, air deflectors, 19" module support and extensive fixing material kit

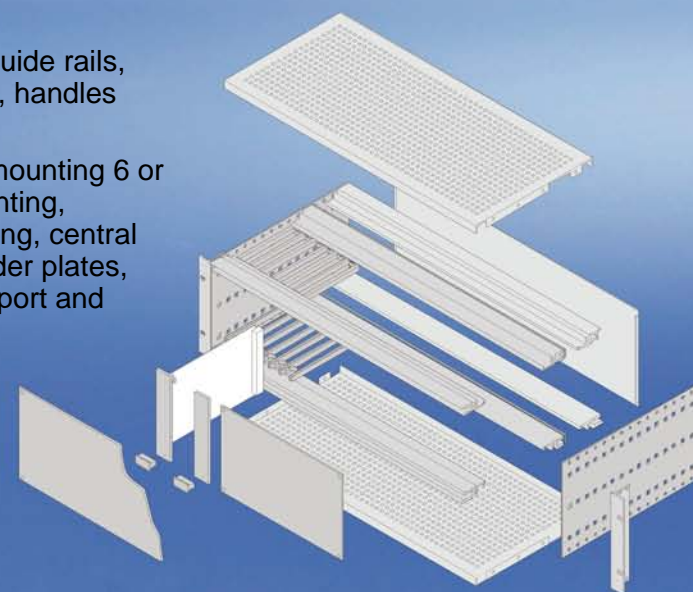

36112002 (01494031 06112002 06112001 06112020)

Overview ... 6.2

Introduction .. 6.4

europacPRO .. 6.6

Subracks for mobile railway applications .. 6.70

europacPRO for industrial applications .. 6.86

europacPRO for rugged applications .. 6.92

Accessories .. 6.17

Subracks - *europacPRO* Introduction

Platform-based standard solutions for individual requirements

Practical technology without time-consuming assembly. The modular europacPRO product platform allows a wide range of possible applications with only a few components. The intelligent design of all components results in remarkably simple and fast management in assembly and components.

Two ways of reaching your desired product:

- Kits
- Individual configuration



Simple assembly with europacPRO kits:

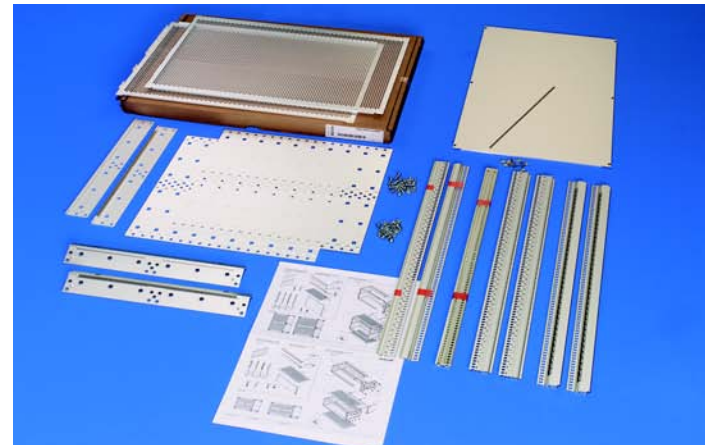

06107001

Delivered in space-saving flat packs. The threaded inserts or EMC gasket (depending on selected kit) are already pre-mounted on the horizontal rail.

Individual configuration:

	Side panel type F	19" bracket without handle holes	19" bracket with handle holes	19" bracket depth-adjustable	EMC sealing (SI, stainless)	Rear angle	Side panel connection
	without 19" bracket, Al, 2 mm, passivated please order 19" bracket and corner profile separately	with lateral grooves for EMC stainless steel gasket, Al extrusion, rear side etched, front anodized	with lateral grooves for EMC stainless steel gasket, Al extrusion, rear side etched, front anodized, please order front handle separately, see page 6.25	2 adaptor brackets, Al, 2 mm, equipment support rail, height 35 mm, width 84 mm, depth 17.5 mm; mounted laterally in module support or subrack; power	inserted laterally into the slots of the front panel	Al extrusion, surface clear passivated, with lateral grooves for EMC stainless steel sealing; rear hood cannot be mounted simultaneously	Zn die-cast, hot assembly kit, for fitting two by two side panels (above one another)
Height U		1 piece	PU 1 pair	PU 1 pair	PU 10 pieces	PU 1 pair	PU 4 pieces
Depth mm							
3	175	34560-183					
3	235	34560-187					
3	275	34579-300					
3	277.75	34579-002	24560-197	24560-198	24560-199	21101-705	24561-198
3	295	34560-189					21101-954
3	355	34560-191					
3	415	34560-193					
3	475	34560-195					

06109052

You design your subrack as you wish, then receive it fully assembled via our **ServicePLUS assembly service** (even for orders of just one). We can also carry out individual modifications and cut-outs; and when time is short can do so very fast via ServicePLUS express.

Horizontal rails and side panels for different load-carrying classes



Light

06197007

Heavy

06197008

Rugged

06112004

Horizontal rails are available for three load classes:

- "light" (load up to approx. 7.5 kg)
- "heavy" (load > 7.5 kg)
- "rugged" (load 15 kg)

Side panels for 4 different load classes

- Light: low-cost version with built-in 19" mounting bracket
- Flexible: with separate, depth-adjustable 19" mounting bracket
- Heavy: with integrated, tox-cold welded 19" mounting bracket, e.g. for shock and vibration environments up to 5 g
- Rugged: with integrated, tox-cold welded 19" mounting bracket and higher material thicknesses for extreme mechanical stresses, e.g. for increased shock and vibration environments up to 25 g
- The combination of the 3 horizontal rail variants with the 4 types of side panel results in an almost unlimited variety of potential applications for various market requirements

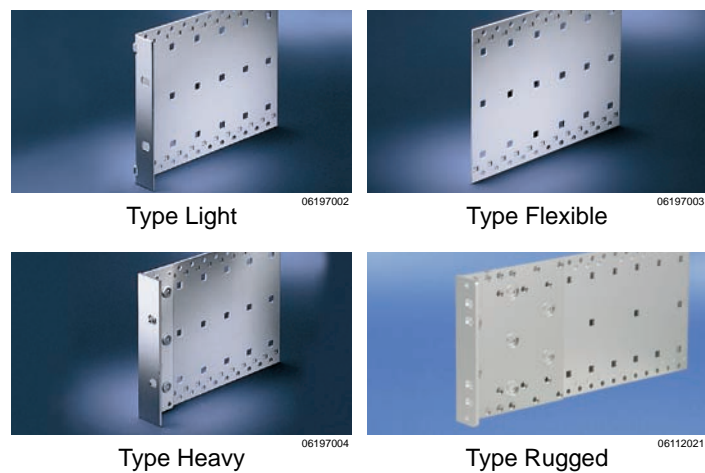

Type Light

06197002

Type Flexible

06197003

Type Heavy

06197004

Type Rugged

06112021

Subracks - *europacPRO* Introduction

Guide rails from plastic and aluminium profiles

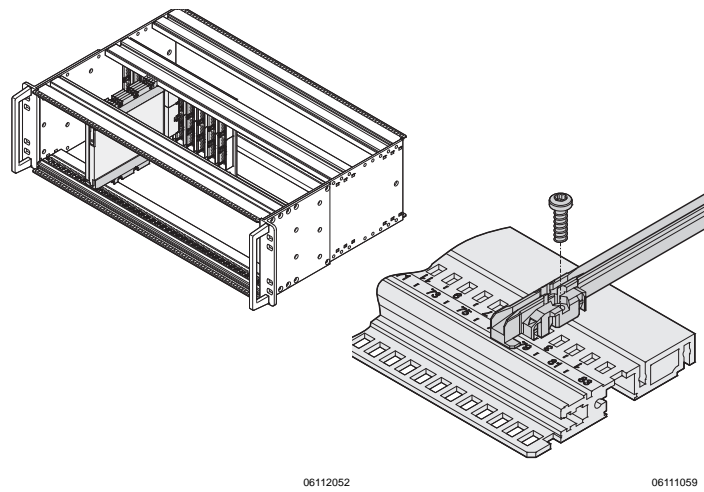

Guide rails form the interface between the subrack mechanics and the assemblies (boards, plug-in units, frame type plug-in units, drive unit modules, ...).

Robust snap-in fixings on the plastic rails assure a secure grip, even when exposed to vibrations. In the case of H and R-type horizontal rails the guide rails can also be bolted on. For extreme stresses, guide rails in aluminium extrusion are used.

To ensure that the wrong subassembly is not inserted into the wrong space we offer a mechanical coding to IEEE 1101.10/11 and IEC 60297-3-103.

The continuous numbering on the horizontal rail (from 28 HP) and the markings on the guide rails facilitate quick fitting in the correct position.

We offer the appropriate adaptors for accommodating VPX or CompactPCI boards with strengthening frame or conduction-cooled assemblies (CCA) installed in a subrack.

Electromagnetic shielding and ESD

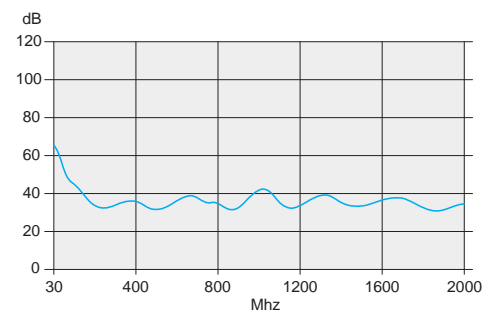

The product platform *europacPRO* offers a variety of off-the-shelf solutions to assure electromagnetic compatibility (EMC) and to avoid electrostatic discharge (ESD).

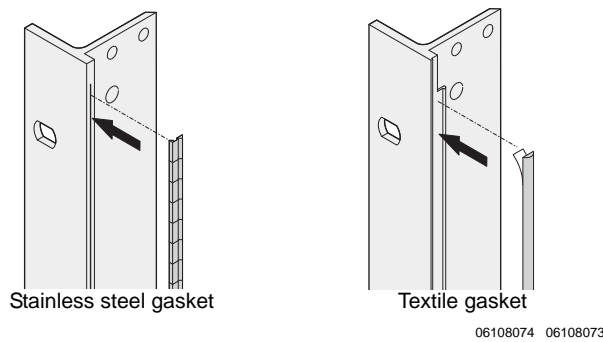

Two shielding concepts It can't be more secure!

Two types of shielding concepts to front/rear of the subrack allow the use all Schroff frontpanels.

The shielding at the front of the subrack is by means of stainless steel or textile EMC gaskets.

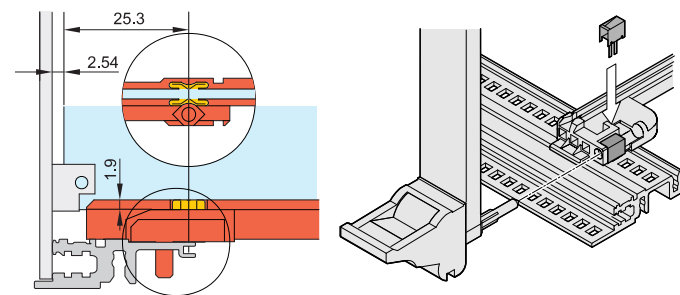

ESD (electrostatic discharge)

To avoid electrostatic discharge when inserting PCBs, ESD contacts are clipped into the guide rails. These establish a conductive connection between PCB and subrack-earth. Under IEC 60297-3-101 two ESD areas are defined on the euroboard. The ESD clips of the guide rail of the *europacPRO* subrack allow the assembly of both following variants:

- ESD area (bottom and top) over the complete board length
- ESD area (bottom/top) begins at the front from 70 mm to end of board)

- Overview 0
- Cabinets 1
- Wall mounted cases 2
- Accessories for cabinets and wall mounted cases 3
- Climate control 4
- Desk-top cases 5
- Subracks/ 19" chassis ... 6**
- Front panels, plug-in units .. 7
- Systems 8
- Power supply units 9
- Backplanes .. 10
- Connectors, front panel component system 11
- Appendix 12

Subracks - *europac PRO*

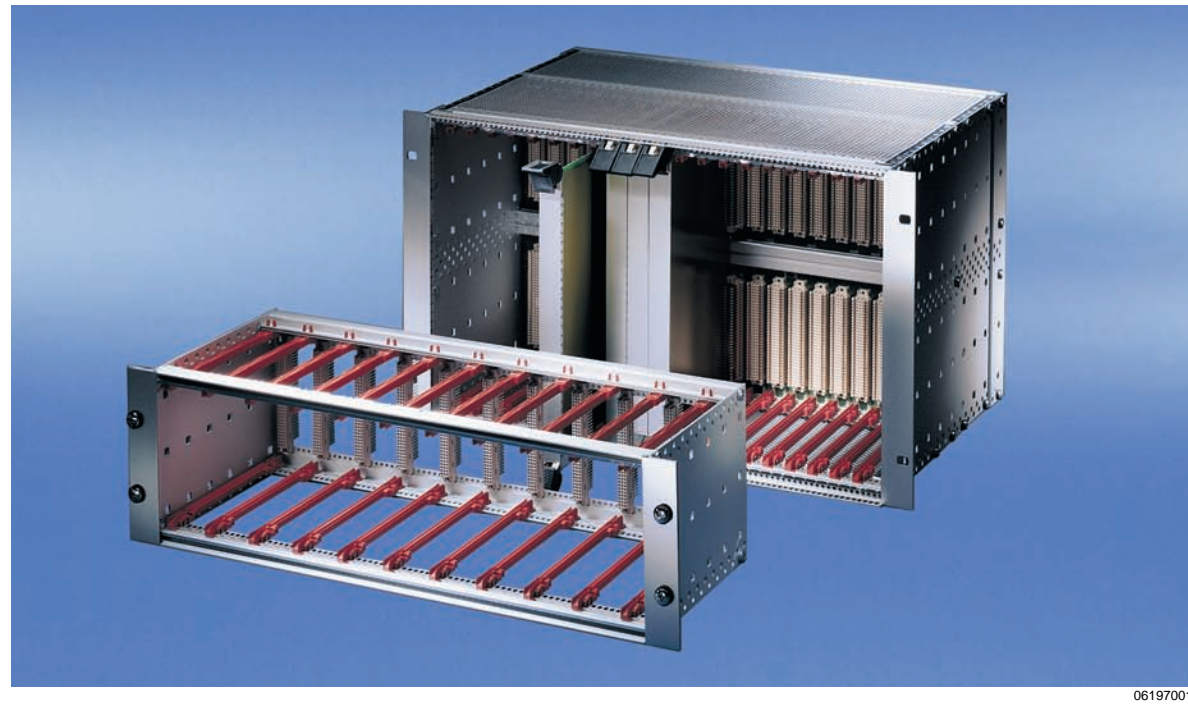

06197001



06112014

Different horizontal rails for various applications



04602002

The IEEE handles and shielded front panels are designed for the construction of CompactPCI and VME64x subrack systems

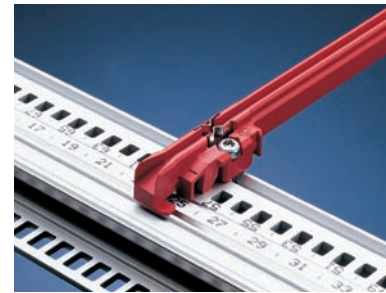

06

Sequential numbering on horizontal rails (> 28 HP) and markings on the guide rails provide quick optical positioning aids. ESD clips can be used at front or rear, to protect electronics from electrostatic discharge

Standards/certifications

- Inner and outer dimensions meet:
IEC 60297-3-100, -101, -102, -103, -104, -105
IEEE 1101.1 and IEEE 1101.10/11
- Type of protection IP 20 to IEC 60529
- EMC testing to IEC 61587-3
- Shock and vibration test reports:
German "Bahn" standards BN 411002, BN 411003;
NF F 60002, NF F 67012
IEC 61587-2, EN 50155
- Nuclear plants KTA 1401

EMC curve

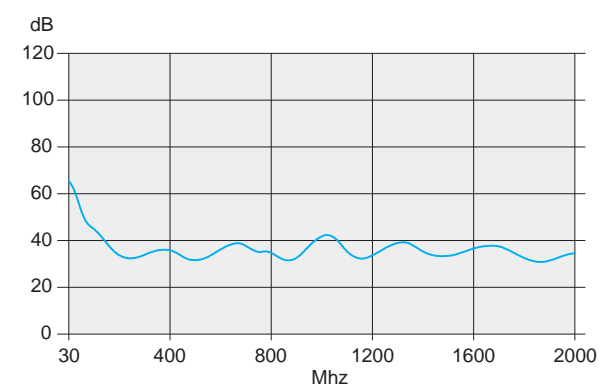

06108081



Downloads and further important information can be found on the Internet under www.schroff.biz

19" subracks

- Kits or individual configuration
- One product and accessories platform for every kind of customer requirement and application
- Suitable for CompactPCI and VME64x insertion and extractor handles
- EMC shielding can easily be retrofitted if needed
- Shock and vibration resistant up to 5 g
- 3D PDF or CAD 3D data available for download

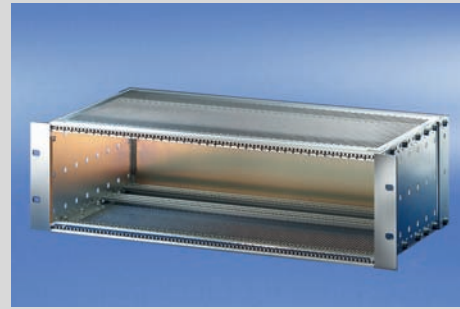

06102008

Kits

- All required parts available under one order number, some pre-fitted
- Most popular dimensions and versions available from stock
- For installed loads up to 7.5 kg, up to 11 kg and up to 15 kg
- As unshielded or shielded version
- Supplied as space-saving flat-pack

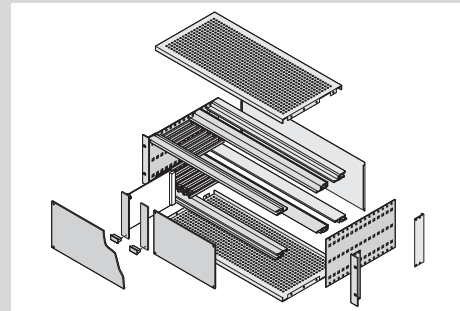

06105058

ServicePLUS individual configuration

- Single parts may individually be configured, respectively assembled on request (from quantity 1)
- Very wide range of variants in height, width and depth
- Guide rails for different applications
- EMC shielding material to improve EMC performance
- Interior assembly options with mounting plate or combined mounting (3 + 6 U segments)
- Other accessories and assembly kits



30407004

ServicePLUS from page 6.16

- e.g. individual configuration and assembly
- e.g. modification (cut-outs)
- e.g. downloads (CAD drawings, user manuals, test reports)
- e.g. custom solutions

www.schroff.biz/ServicePLUS

Overview ... 6.6

Introduction .. 6.4

Kits

- Light 6.8
- Flexible 6.9
- Heavy 6.12
- CompactPCI 6.14

ServicePLUS .. 6.16

ServicePLUS configuration

- Side panels 6.19
- Horizontal rails, threaded inserts, perforated strips 6.27
- Guide rails 6.35
- Cover plates 6.42
- EMC shielding .. 6.52
- Interior assemblies 6.57
- Assembly kits ... 6.63
- Application examples 6.69

Subracks for mobile railway applications .. 6.70

europacPRO for industrial applications .. 6.86

europacPRO for rugged applications .. 6.92

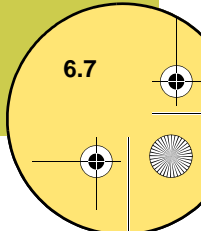

Subracks - *europac PRO*

Kit, "light", unshielded,
for backplane mounting

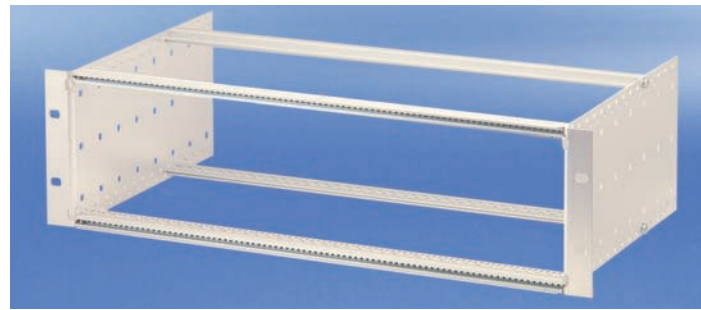

- Subrack with side panel type L ("light") with firmly fixed 19" brackets
- Rear horizontal rails for backplane mounting with insulation strip
- Installed load up to 7.5 kg
- Cost-optimised

NEW

Delivery comprises (Kit)

Item	Qty	Description	
3 U		6 U	
1	2	2	Side panel type L, Al, 2 mm, passivated, with built-in 19" support bracket
2a	2	2	Front horizontal rail (L-KD)
2b	2	2	Rear horizontal rail (L-ST)
2c	-	1	Rear horizontal rail centre (ST)
3	4	6	Threaded insert, front and rear (pre-fitted)
4	2	4	Insulation strip (pre-fitted)
5	1	1	Fixing material kit, user manual

Order Information

Height U	Width HP	Depth D mm	Depth D1 mm	Part no.
3	84	175	175	24564-131
3	84	235	175/235	24564-132
3	84	295	175/235/295	24564-133
6	84	175	175	24564-431
6	84	235	175/235	24564-432
6	84	295	175/235/295	24564-433

Accessories

19" assembly kit (screw, washer, nut) (8 x screws, 8 x plastic washers, 8 x cage nuts) 21100-435

Guide rails (standard), ESD clips

Depth D2 mm	Qty/PU piece	Part no.
160	10	24560-351
220	10	24560-353
280	10	24560-379

ESD clips for guide rails PU 50 pieces 24560-255

Cover plates for insertion in horizontal rails (type L)

Depth D2 mm	Width HP	Qty/PU piece	Part no.
160	84	2	24561-051
220	84	2	24561-052

Note

- Subrack is not prepared for shielding
- ServicePLUS configuration from page 6.16



For further information www.schroff.biz/oneclick
oneClick search code = Part no.

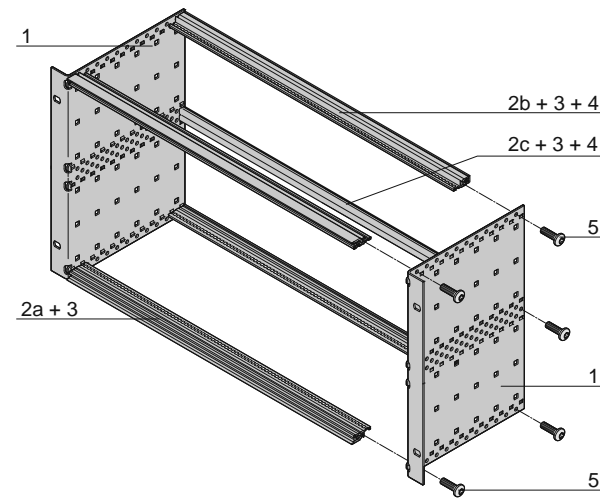

6 U

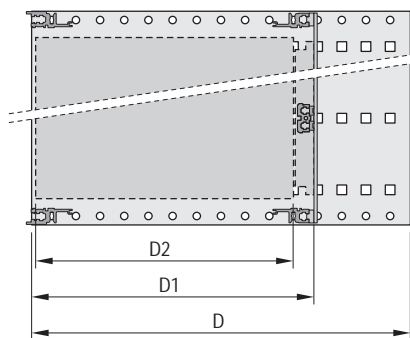

D = overall depth, D1 = insertion depth,
D2 = board depth = D1 - 15 mm



Rear horizontal rail for backplane mounting with insulation strip



ServicePLUS see page 6.16

6.8

Main Catalogue
E 10/2012

Part number in bold face type: ready for despatch within 2 working days
Part number in normal type: ready for despatch within 10 working days

Subracks - *europac PRO*

Kit, "flexible", unshielded,
for connector mounting

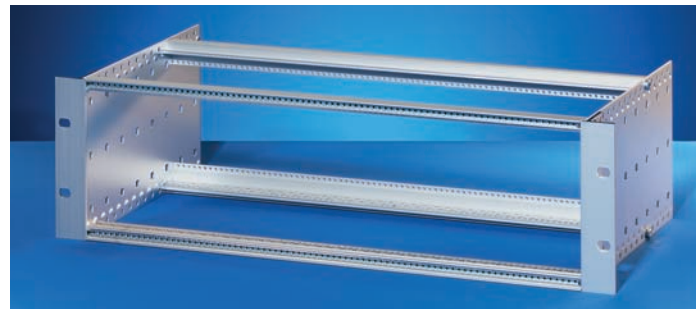

Photo: 3 U subrack

- Subrack with side panel type F ("flexible"), 19" bracket is depth-adjustable
- Rear horizontal rails for connector mounting (IEC 60603-2 / DIN 41612)
- Installed load up to 11 kg

Delivery comprises (kit)

Item	Qty	Description	
3 U		6 U	
1	2	2	19" support bracket, Al extrusion, for EMC gasket (St, stainless)
2	2	2	Side panel type F, Al, 2 mm
3a	2	2	Front horizontal rail (L-KD)
3b	2	2	Rear horizontal rail (L-MZ) for connector mounting
3c	-	1	Centre horizontal rail (MZ)
4	2	2	Threaded insert to front (pre-fitted)
5	1	1	Fixing material kit, user manual

Order Information

Height U	Width HP	Depth D mm	Depth D1 mm	Part no.
3	84	175	175	24563-191
3	84	235	175/235	24563-192
3	84	295	175/235/295	24563-193
3	84	355	175/235/295/355	24563-194
6	84	175	175	24563-491
6	84	235	175/235	24563-492
6	84	295	175/235/295	24563-493
6	84	355	175/235/295/340	24563-494

Accessories

19" assembly kit (screw, washer, nut) (8 x screws, 8 x plastic washers, 8 x cage nuts)	21100-435
--	-----------

Guide rails (standard), ESD clips

Depth D2 mm	Qty/PU piece	Part no.
160	10	24560-351
220	10	24560-353
280	10	24560-379
340	10	24560-380

ESD clip for guide rails PU 50 pieces 24560-255

Cover plates for insertion in horizontal rails (type L)

Depth D2 mm	Width HP	Qty/PU piece	Part no.
160	84	2	24561-051
220	84	2	24561-052

Note

- ServicePLUS configuration from page 6.16



For further information www.schroff.biz/oneclick
oneClick search code = Part no.

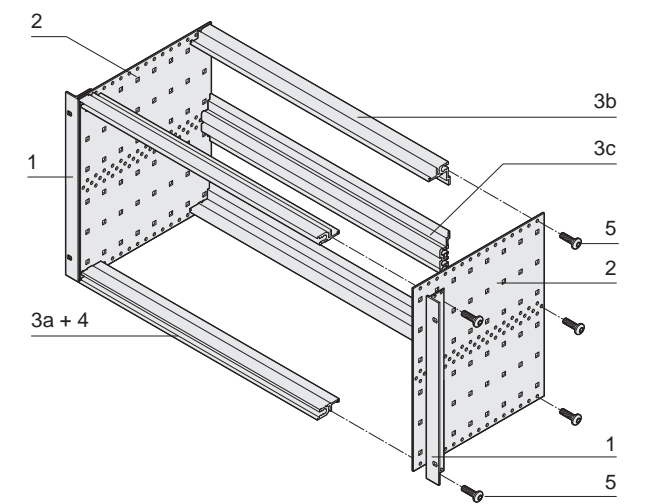

6 U

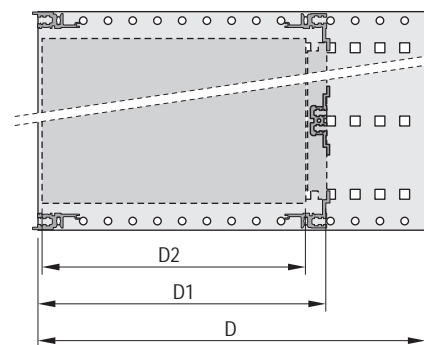

D = overall depth, D1 = insertion depth,
D2 = board depth = D1 - 15 mm



Horizontal rail to rear for connector mounting



ServicePLUS see page 6.16

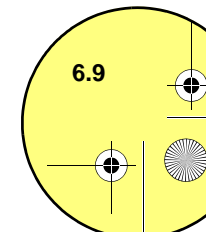

Subracks - *europac PRO*

Kit, "flexible", unshielded, for backplane mounting

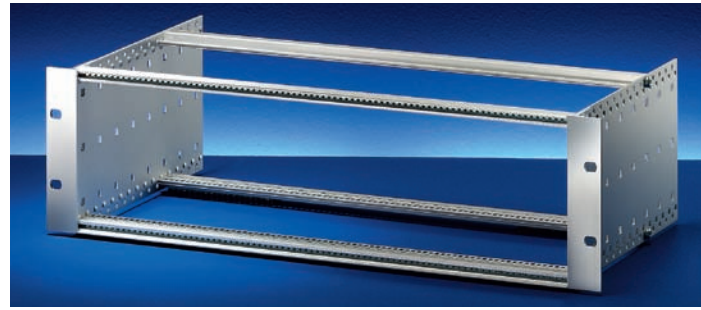

- Subrack with side panel type F ("flexible"), 19" bracket is depth-adjustable
- Rear horizontal rail for backplane mounting with insulation strip
- Installed load up to 11 kg

Delivery comprises (kit)

Item	Qty	Description	
3 U		6 U	
1	2	2	19" support bracket, Al extrusion, for EMC stainless steel gasket
2	2	2	Side panel type F, Al, 2 mm
3a	2	2	Front horizontal rail (L-KD)
3b	2	2	Rear horizontal rail (L-ST) for backplane mounting
3c	-	1	Rear horizontal rail centre (ST)
4	4	6	Threaded insert, front and rear (pre-fitted)
5	2	4	Insulation strip (pre-fitted)
6	1	1	Fixing material kit, user manual

Order Information

Height U	Width HP	Depth D mm	Depth D1 mm	Part no.
3	84	175	175	24563-131
3	84	235	175/235	24563-132
3	84	295	175/235/295	24563-133
3	84	355	175/235/295/355	24563-134
3	84	415	175/235/295/355	24563-135
3	84	475	175/235/295/355	24563-136
6	84	175	175	24563-431
6	84	235	175/235	24563-432
6	84	295	175/235/295	24563-433
6	84	355	175/235/295/355	24563-434
6	84	415	175/235/295/355	24563-435
6	84	475	175/235/295/355	24563-436

Accessories

19" assembly kit (screw, washer, nut) (8 x screws, 8 x plastic washers, 8 x cage nuts) 21100-435

Guide rails (standard), ESD clips

Depth D2 mm	Qty/PU piece	Part no.
160	10	24560-351
220	10	24560-353
280	10	24560-379
340	10	24560-380

ESD clip for guide rails PU 50 pieces 24560-255

Cover plates for insertion in horizontal rails (type L)

Depth D2 mm	Width HP	Qty/PU piece	Part no.
160	84	2	24561-051
220	84	2	24561-052

Note

- ServicePLUS configuration from page 6.16

For further information www.schroff.biz/oneclick
oneClick search code = Part no.

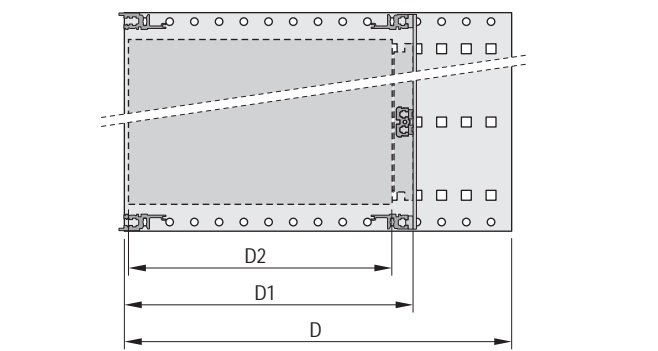
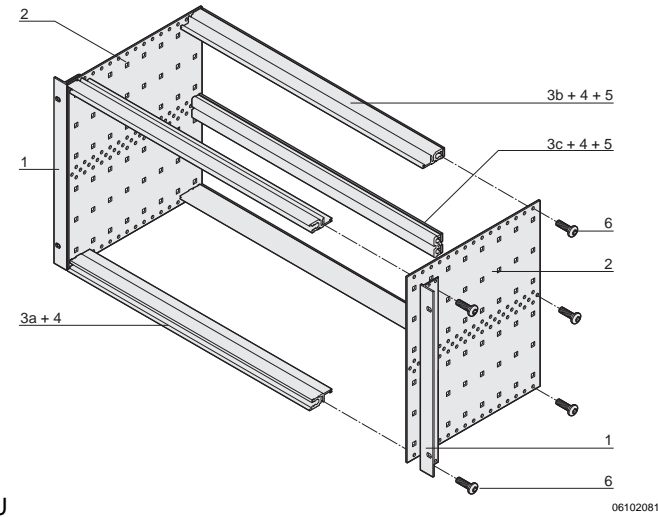

D = overall depth, D1 = insertion depth, D2 = board depth = D1 - 15 mm

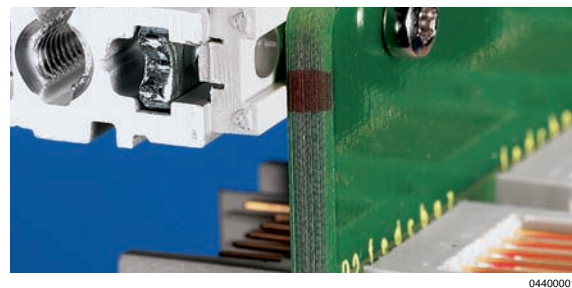

Rear horizontal rail for backplane mounting with insulation strip



ServicePLUS see page 6.16

Subracks - *europac PRO*

Kit, "flexible", shielded,
for backplane mounting

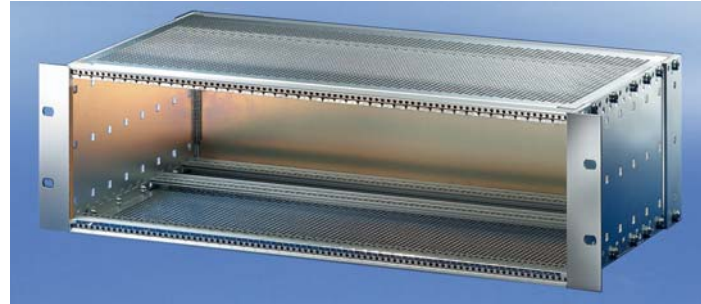

06102008

- Subrack with side panel type F ("flexible"), 19" bracket is depth-adjustable
- Rear horizontal rail for backplane mounting with insulation strip
- Shielding typically 40 dB at 1 GHz, 30 dB at 2 GHz, assuming that the front is closed with shielded front panels
- Installed load up to 11 kg

Delivery comprises ((kit))

Item	Qty		Description
	3 U	6 U	
1	2	2	19" support bracket for EMC textile gasket
2	2	2	Rear corner profile for EMC textile gasket
3	2	2	Side panel type F
4	2	2	Front horizontal rail (L-KD)
4 a	2	2	Rear horizontal rail (L-KD)
4 b	2	2	Rear horizontal rail (L-ST) for backplane mounting with insulation strip
4 c	-	1	Centre horizontal rail (ST)
5	6	8	Threaded insert (pre-fitted)
6	2	4	Insulation strip, fixed
7	2	2	EMC cover plate
8	1	1	EMC gasketing material (pre-fitted)
9	1	1	Rear panel
10	1	1	Fixing material kit
11	2	2	Perforated strip (pre-fitted)
12	1	1	User manual

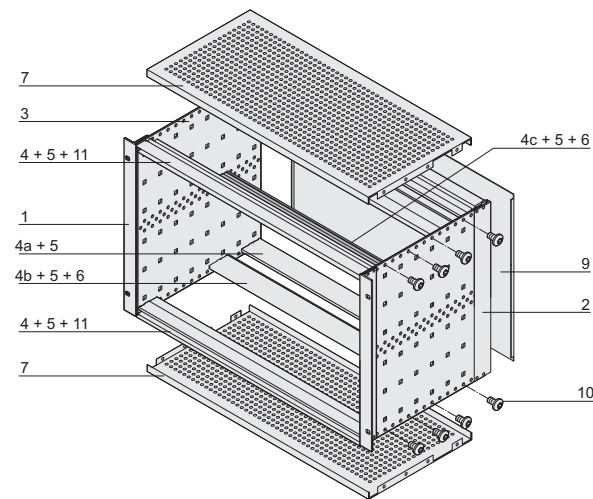

06102075

Order Information

Height U	Width HP	Depth D mm	Depth D1 mm	Part no.
3	84	235	175/235	24563-142
3	84	295	175/235/295	24563-143
3	84	355	175/235/295	24563-144
3	84	415	175/235/295	24563-145
3	84	475	175/235/295	24563-146
6	84	235	175/235	24563-442
6	84	295	175/235/295	24563-443
6	84	355	175/235/295	24563-444
6	84	415	175/235/295	24563-445
6	84	475	175/235/295	24563-446

Accessories

19" assembly kit (screw, washer, nut) (8 x screws, 8 x plastic washers, 8 x cage nuts) 21100-435

Guide rails (standard), ESD clips

Depth D2 mm	Qty/PU piece	Part no.
160	10	24560-351
220	10	24560-353
280	10	24560-379
340	10	24560-380
ESD clip for guide rails PU 50 pieces		24560-255

Note

- ServicePLUS configuration from page 6.16



For further information www.schroff.biz/oneclick
oneClick search code = Part no.

6 U

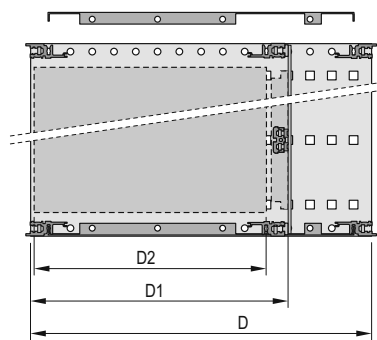

06113056

D = overall depth, D1 = insertion depth,
D2 = board depth = D1 - 15 mm



04400001

Rear horizontal rail for backplane mounting with insulation strip



ServicePLUS see page 6.16

Subracks - *europac PRO*

Kit, 'heavy', unshielded,
for backplane mounting

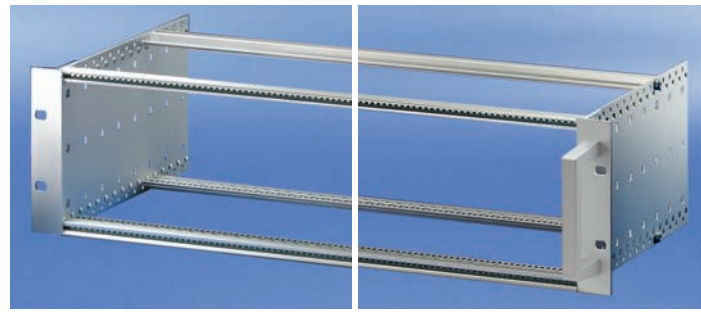

- Subrack with side panel type H ("heavy"), 19" bracket is firmly fixed to side panel (tox-cold welded)
- Rear horizontal rail for backplane mounting with insulation strip
- Shock and vibration resistance up to 5 g
- Installed load up to 15 kg
- Versions with/without front handles

NEW

Delivery comprises (Kit)

Item	Qty	Description	
	3 U	6 U	
1	2	2	Side panel type H, Al, 2 mm, passivated, with 19" support bracket (tox-cold welded) for textile EMC gasket
2a	2	2	Front horizontal rail (H-KD)
2b	2	2	Rear horizontal rail (H-ST)
2c	-	1	Rear horizontal rail centre (H-ST)
3	4	6	Threaded insert, front and rear (pre-fitted)
4	2	4	Insulation strip (pre-fitted)
5	1	1	Fixing material kit, user manual
6	2	2	Front handle (on version with front handle only)

Order Information

Height U	Width HP	Depth D mm	Depth D1 mm	Part no. with front handle	Part no. without front handle
3	84	175	175	24567-161	24563-161
3	84	235	175/235	24567-162	24563-162
3	84	295	175/235/295	24567-163	24563-163
3	84	355	175/235/295/355	24567-164	24563-164
6	84	175	175	24567-461	24563-461
6	84	235	175/235	24567-462	24563-462
6	84	295	175/235/295	24567-463	24563-463
6	84	355	175/235/295/355	24567-464	24563-464

Accessories

19" assembly kit (screw, washer, nut) (8 x screws, 8 x plastic washers, 8 x cage nuts) 21100-435

Guide rails (standard), ESD clips

Depth D2 mm	Qty/PU piece	Part no.
160	10	24560-351
220	10	24560-353
280	10	24560-379
340	10	24560-380

ESD clip for guide rails PU 50 pieces 24560-255

Torx panhead screw, for extra bolting of the guide rails, 2.5 x 9.3, zinc-plated, PU 100 pieces; torque max. 0.2 Nm 24560-141

Cover plates for bolting to side panel

Depth D2 mm	Width HP	Qty/PU piece	Part no.
160	84	2	24560-078
220	84	2	24560-079
280	84	2	24560-080
340	84	2	24560-081

Note

- ServicePLUS configuration from page 6.16

Part number in bold face type: ready for despatch within 2 working days
Part number in normal type: ready for despatch within 10 working days

Without front handle

With front handle

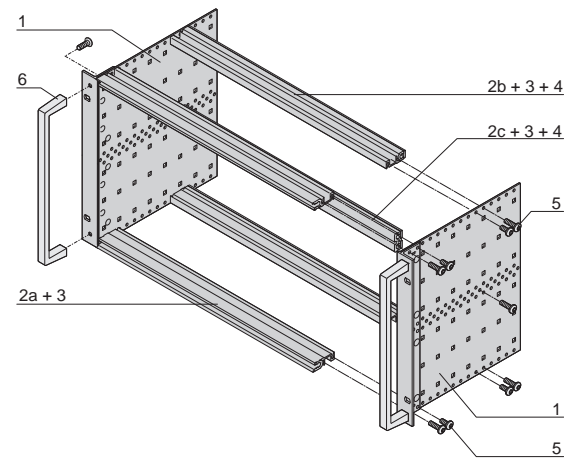

6 U

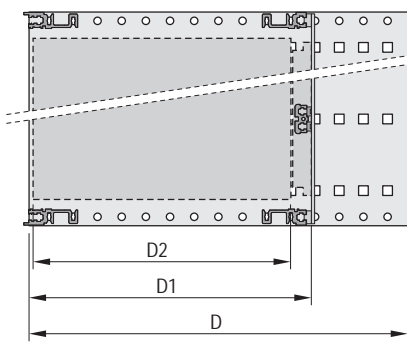

D = overall depth, D1 = insertion depth, D2 = board depth



Rear horizontal rail for backplane mounting with insulation strip



ServicePLUS see page 6.16

Subracks - *europac PRO*

Kit, "heavy", shielded,
for backplane mounting

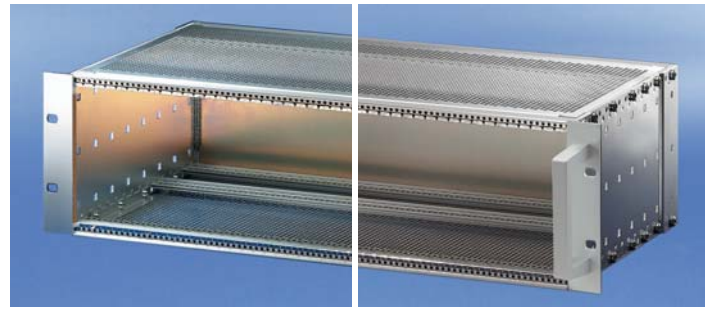

- Subrack with side panel type H ("heavy"), 19" bracket is firmly fixed to side panel (tox-cold welded)
- Rear horizontal rail for backplane mounting with insulation strip
- Shielding typically 40 dB at 1 GHz, 30 dB at 2 GHz, assuming that the front is closed with sealed front panels
- Shock and vibration resistance up to 5 g
- Installed load up to 15 kg
- Versions with/without front handles

NEW

Delivery comprises (Kit)

Item	Qty	Description	
	3 U	6 U	
1	2	2	Side panel type H, Al, 2 mm, passivated, with 19" support bracket (tox-cold welded); for textile EMC gasket
2	2	2	Rear corner profile for textile EMC gasket
3	2	2	Front horizontal rail (H-KD)
3 a	2	2	Rear horizontal rail (H-KD)
3 b	2	2	Rear horizontal rail (H-ST)
3 c	-	1	Rear horizontal rail centre (ST)
4	6	8	Threaded insert (pre-fitted)
5	2	2	Perforated strip (pre-fitted)
6	2	4	Insulation strip (pre-fitted)
7	2	2	EMC cover plate
8	1	1	EMC gasketing material (pre-fitted)
9	1	1	EMC rear panel
10	1	1	Fixing material kit, user manual
11	2	2	Front handle (on version with front handle only)

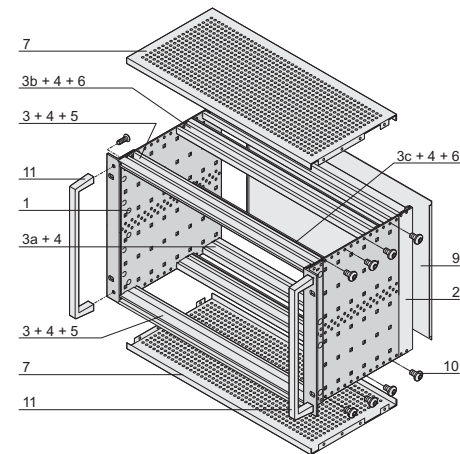

0611058

Order Information

Height U	Width HP	Depth D mm	Depth D1 mm	Part no. with front handle	Part no. without front handle
3	84	235	175/235	24567-172	24563-172
3	84	295	175/235/295	24567-173	24563-173
3	84	355	175/235/295	24567-174	24563-174
6	84	235	175/235	24567-472	24563-472
6	84	295	175/235/295	24567-473	24563-473
6	84	355	175/235/295	24567-474	24563-474

06113055

Accessories

19" assembly kit (screw, washer, nut) (8 x screws, 8 x plastic washers, 8 x cage nuts) 21100-435

Guide rails (standard), ESD clips

Depth D2 mm	Qty/PU piece	Part no.
160	10	24560-351
220	10	24560-353
280	10	24560-379

ESD clip for guide rails PU 50 pieces 24560-255

Torx panhead screw, for extra bolting of the guide rails, 2.5 x 9.3, zinc-plated, PU 100 pieces; torque max. 0.2 Nm 24560-141

Note

- ServicePLUS configuration from page 6.16

6 U

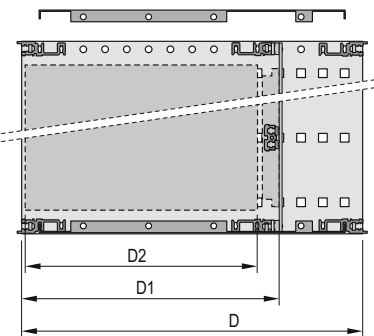

06113055

D = overall depth, D1 = insertion depth,
D2 = board depth = D1 - 15 mm



04400001

Rear horizontal rail for backplane mounting with insulation strip



ServicePLUS see page 6.16

Subracks - *europac PRO*

Kit, for CompactPCI, for backplane mounting, without rear I/O, shielded

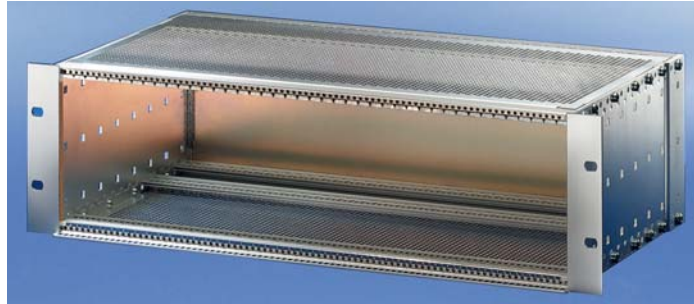

06102009

- Subrack with side panel type F ("flexible") for CompactPCI plug-in units with high insertion and withdrawal forces
- Rear horizontal rail for backplane mounting with insulation strip
- Shielding typically 40 dB at 1 GHz, 30 dB at 2 GHz, assuming that the front is covered with shielded front panels
- Installed load up to 11 kg

Delivery comprises (kit)

Item	Qty		Description
	3 U	6 U	
1	2	2	19" support bracket for EMC textile gasket
2	2	2	Rear corner profile for EMC textile gasket
3	2	2	Side panel type F
4	1	-	Front horizontal rail (H-KD)
4 a	1	2	Front horizontal rail IEEE (H-LD)
4 b	2	2	Rear horizontal rail (L-KD)
4 c	2	2	Rear horizontal rail (H-ST), for backplane mounting with insulation strip
4 d	-	1	Centre horizontal rail (ST)
5	6	8	Threaded insert (pre-fitted)
6	2	4	Insulation strip (pre-fitted)
7	2	2	EMC cover plate
8	1	1	EMC gasketing material (pre-fitted)
9	1	1	Rear panel
10	1	1	Fixing material kit
11	2	2	Perforated strip (pre-fitted in item 4+4a)
12	1	1	User manual

6 U

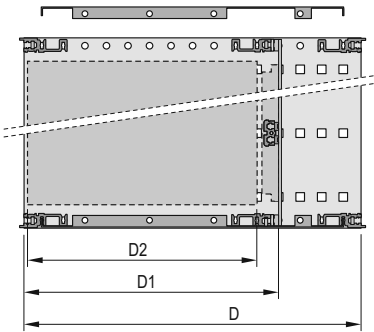
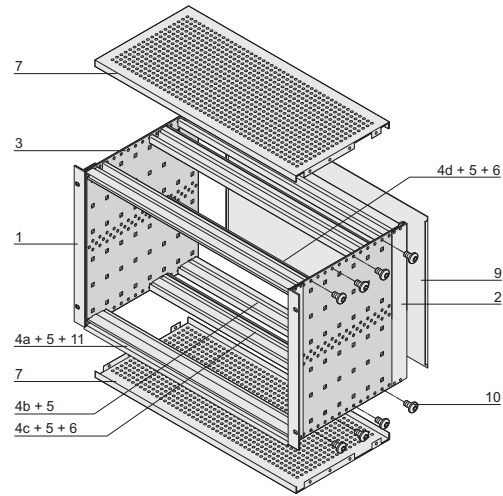

06102078

Order Information

Height	Width	Depth D	Depth D1	Part no.
U	HP	mm	mm	
3	84	235	175	24563-152
6	84	235	175	24563-452

Accessories

Guide rail with coding, red 160 mm deep, PBT, UL 94 V-0, groove width 2 mm, PU 10 pieces	24560-356
Guide rail with coding, grey 160 mm deep, PBT, UL 94 V-0, groove width 2 mm, PU 10 pieces	24560-358
Guide rail with coding, green, offset 160 mm deep, PBT, UL 94 V-0, groove width 2 mm, PU 10 pieces	24560-359
ESD clip for guide rails PU 50 pieces	24560-255
ESD clip for alignment pin of CPCI/VME64x handle PU 50 pieces	24560-256
Torx panhead screw 2.5 x 9.3, zinc-plated, PU 100 pieces; torque max. 0.2 Nm	24560-141
Coding peg PC, UL 94 V-0, RAL 7035, PU 100 pieces	20817-501
19" assembly kit (screw, washer, nut) (8 x screws, 8 x plastic washers, 8 x cage nuts)	21100-435

06113055

Note

- ServicePLUS configuration from page 6.16



For further information www.schroff.biz/oneclick
oneClick search code = Part no.

D = overall depth, D1 = insertion depth,
D2 = board depth = D1 - 15 mm



04400001

Rear horizontal rail for backplane mounting with insulation strip



ServicePLUS see page 6.16

Subracks - *europac PRO*

Kit, for CompactPCI, for backplane mounting, for rear I/O, shielded

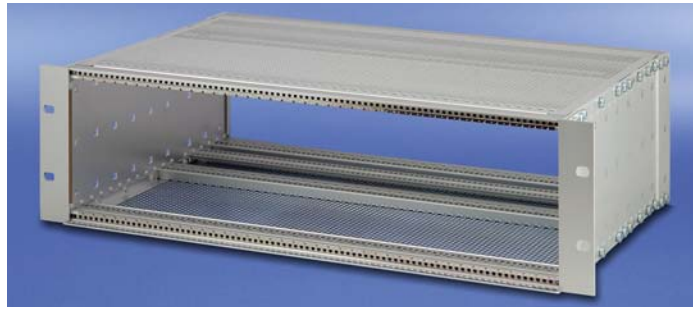

- Subrack with side panel type F ("flexible") for CompactPCI plug-in units with high insertion and withdrawal forces
- For rear I/O boards (depth 80 mm)
- Rear horizontal rail for backplane mounting with insulation strip
- Shielding typically 40 dB at 1 GHz, 30 dB at 2 GHz, assuming that the front is covered with shielded front panels
- Installed load up to 11 kg

Delivery comprises (kit)

Item	Qty	3 U	6 U	Description
1	2	2		19" support bracket for EMC textile gasket
2	2	2		Rear corner profile for EMC textile gasket
3	2	2		Side panel type F
4	1	-		Front horizontal rail (H-KD)
4 a	1	2		Front horizontal rail IEEE (H-LD)
4 b	2	2		Rear horizontal rail (H-KD)
4 c	2	2		Rear horizontal rail (H-ST), with insulation strip for backplane mounting
4 d	-	1		Centre horizontal rail (ST)
5	6	8		Threaded insert (pre-fitted)
6	2	4		Insulation strip, fixed
7	2	2		EMC cover plate
8	1	1		EMC gasketing material (pre-fitted)
9	1	1		Fixing material kit
10	2	2		Perforated strip (pre-fitted)
11	2	2		Horizontal rail type AB
12	1	1		User manual

6 U

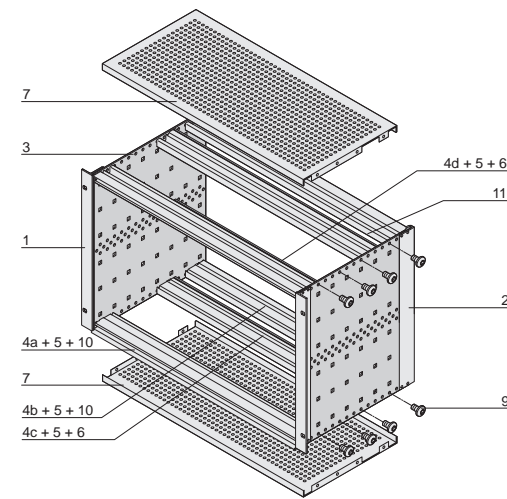

06108076

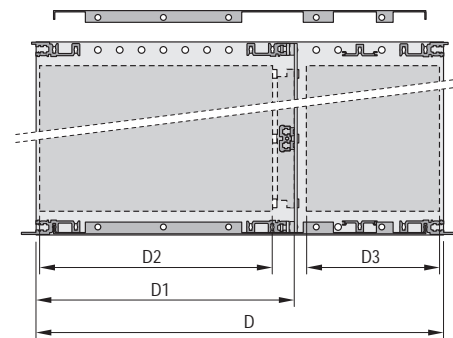

06108075

D = overall depth, D1 = insertion depth,
D2 = board depth = D1 - 15 mm, D3 = rear I/O board depth



04400001

Rear horizontal rail for backplane mounting with insulation strip

Order Information

Height	Width	Depth D	Depth D1	Depth D3	Part no.
U	HP	mm	mm	mm	
3	84	275	175	80	24563-157
6	84	275	175	80	24563-457

Accessories

Guide rail with coding, red 160 mm deep, PBT, UL 94 V-0, groove width 2 mm, PU 10 pieces	24560-356
Guide rail with coding, grey 160 mm deep, PBT, UL 94 V-0, groove width 2 mm, PU 10 pieces	24560-358
Guide rail with coding, green, offset 160 mm deep, PBT, UL 94 V-0, groove width 2 mm, PU 10 pieces	24560-359
ESD clip for guide rails PU 50 pieces	24560-255
ESD clip for alignment pin of CPCI/VME64x handle PU 50 pieces	24560-256
Guide rail with coding, red 70 mm deep, PU 10 pieces	24560-355
Guide rail with coding, grey 70 mm deep, PU 10 pieces	24560-360
Torx panhead screw 2.5 x 9.3, zinc-plated, PU 100 pieces; torque max. 0.2 Nm	24560-141
Coding peg PC, UL 94 V-0, RAL 7035, PU 100 pieces	20817-501
19" fixing material kit (screw, washer, nut) (8 x screws, 8 x plastic washers, 8 x cage nuts)	21100-435

Note

- ServicePLUS configuration from page 6.16



ServicePLUS see page 6.16

Main Catalogue
E 10/2012

Part number in bold face type: ready for despatch within 2 working days
Part number in normal type: ready for despatch within 10 working days

6.15



configuration

Simple. Fast. To the ideal product.

Components can be varied and combined freely

- Configuration tables from page 6.17
- Online configuration: www.schroff.co.uk/configuration



assembly

Assembled by professionals. Double benefit!

Fitting of all mechanical, electrical and electronic components by our specialists

- Professional and reliable from quantity 1
- Ready for despatch within 5 working days



modification

Small changes. Large impact.

Custom drillings, cut-outs and special colours for off-the-shelf products

- Custom modifications from quantity 1
- Ready for despatch within 10 working days



solution

Simple. Fast. From one source.

Integration and custom developments

- Special sizes (depth and width)
- Individual heat dissipation concepts
- Ready for despatch within 10 working days



express

When fast has to be faster.

Delivery time to customer's request

- Express logistics



academy

Knowledge. Sharing. Partnerships.

Knowledge transfer and partnership

- Seminars, CAD drawings, test reports, user reports

Overview of individual components for shielded or unshielded subracks

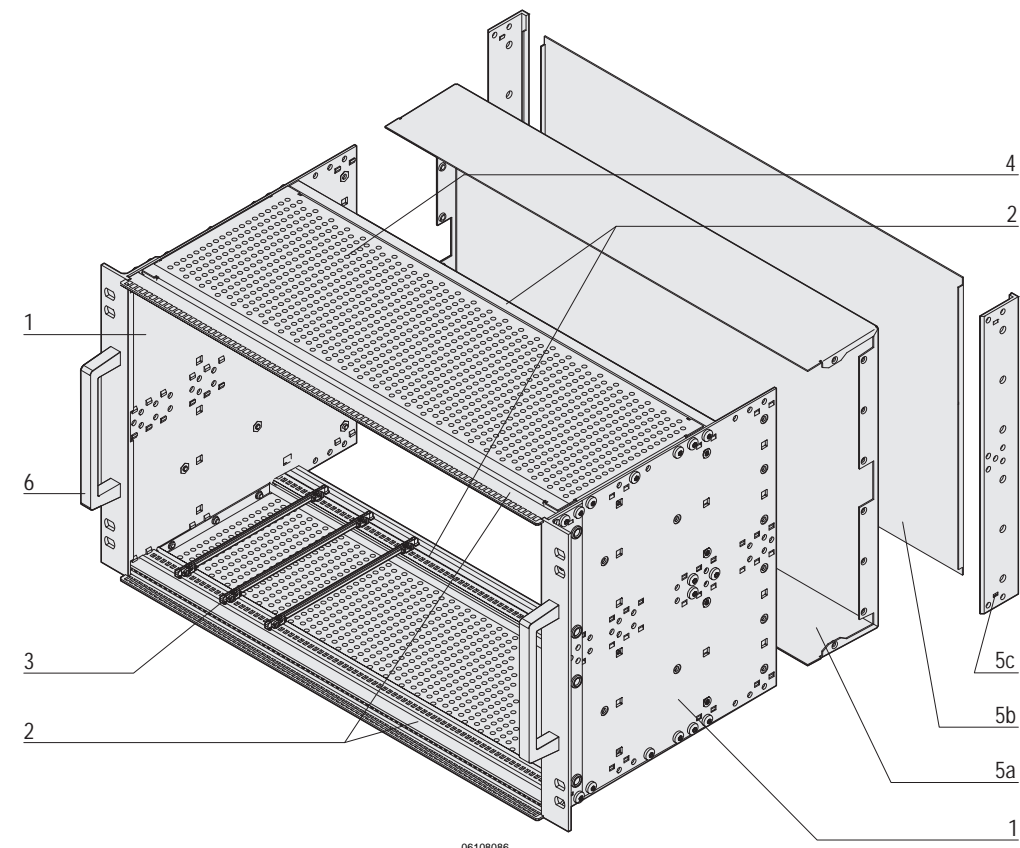

06108086

Item	Description	Description	page
Item 1	Side panel	Establishes the height and depth of the subrack; Al, 2 mm, with universal hole positions for assembly of accessories. Three versions: The "flexible" one with separate 19" brackets as well as two others with integrated 19" brackets for "light" and "heavy" applications.	6.19
Item 2	Horizontal rail	Establishes the width of the subrack; Al extrusion, with defined hole positions for guide rails, grooves for threaded inserts, M4 thread, functional rail shapes, basically differing with regard to their mechanical loading capacity: "light" (load up to 7.5 kg) and "heavy" (load > 7.5 kg).	6.27
Item 3	Guide rails	Act as interface between subracks and boards, for different board formats, are available in plastic or metal, optionally codable and can be fitted with ESD clips to allow electrostatic discharge, also optionally.	6.35
Item 4	Cover plates	Provide mechanical protection and/or EMC shielding and are perforated.	6.42
Item 5	Rear/front	Rear hood (5a) or front panel (5b) with corner profile (5c) act as support for EMC shielding gaskets used in conjunction with shielded front panels. Note: Rear hood and corner profile cannot be fitted simultaneously.	6.47
Item 6	Handles	Can be mounted on the 19" brackets.	6.25
-	EMC shielding (without illustration)	Extensive component range for specific shielding of subracks with respect to their application.	6.52
-	Interior assemblies (without illustration)	Universal assemblies, e.g. for horizontal and vertical assembly and for mounting plates.	6.57

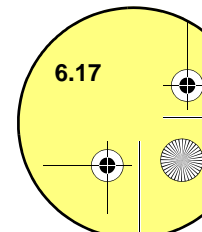

Subrack dimensions

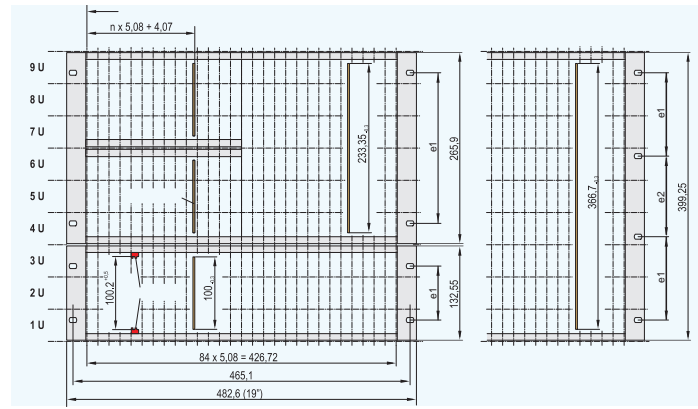

20304051

- Dimensions in accordance with international standards EC 60297-3-100, IEEE 1101.1/.10/.11; please see the Schroff Standards Summary for details
- Side panels
 - Aluminium, 2 mm
 - Round holes for mounting horizontal rails (depth grid 15 mm)
 - Impressions on the inner side of the side panel act as an anti-rotation guard and positioning aid for the horizontal rails
 - Square holes (6 x 6 mm) provide universal fixing for components such as backplane shielding; version without square holes available on request

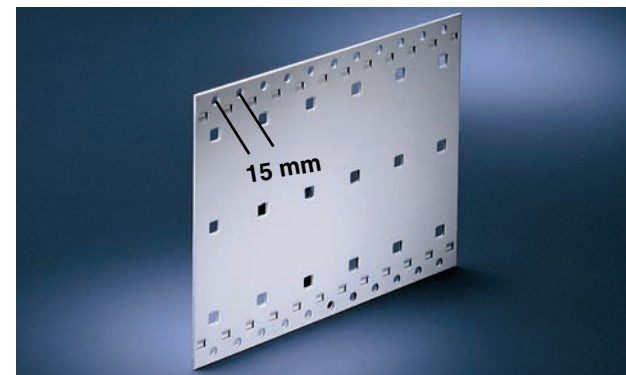

06103001

Depth grid

The depth grid is 15 mm, the mounting holes in the side panel are decisive for the configurability of individual components; thus any combination of various individual parts is possible



06108008

Side panel 3 U, 6 U and 9 U

3 and 6 U side panels have the same hole positions (the 6 U is a doubling vertically of the 3 U); thus subdivisions can be made in the vertical dimension (6 U: 2 x 3 U; 9 U: 3 x 3 U)

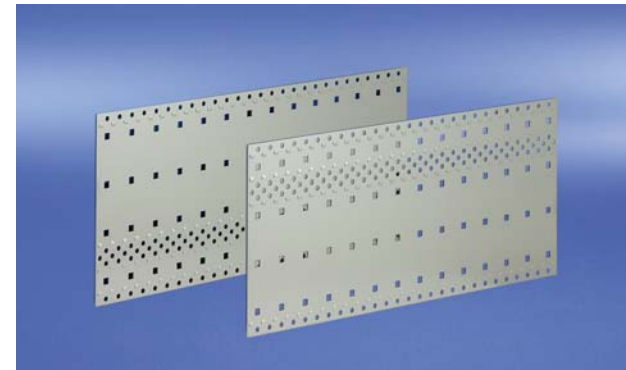

06108011

Side panel 4 U

4 U side panels have the same hole positions as 3 U and additionally 1 U (above or beneath the 3 U installation); this height allows the construction of a 3 U unit with 1 U clearance for cabling or airflow

Side panels

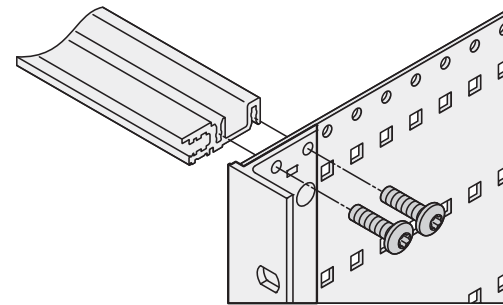

Side panel - horizontal rail assembly

- Aluminium
- Round holes for mounting horizontal rails (depth grid 15 mm)
- Impressions on the inner side of the side panel act as an anti-rotation guard and positioning aid for the horizontal rails
- Square holes (6 x 6 mm) provide universal fixing for components such as backplane shielding; version without square holes available on request
- Only one type of screw driver is needed for the assembly (torx panhead screw, M4 x 14; torque side panel - horizontal rail 2.4 Nm; torque side panel - cover plate 1.3 Nm)
- 4 versions of the side panel:
 - Type F = flexible
 - Type H = heavy
 - Type L = light
 - Type R = rugged

Note

- Type R - rugged side panels see "Rugged Subracks" section, page 6.97

Type F (flexible)

- Universal version: 19" bracket (please order separately) can be fitted variably to front, rear or depth-offset
- Heights: 3, 4, 6 and 9 U
Depths: 175, 235, 275, 277.75, 295, 355, 415 and 475 mm;
Other dimensions on request
- 2 EMC shielding concepts for the front/rear: stainless steel or textile EMC gasket
- Installed load up to 11 kg

Type H (heavy)

- 19" bracket is tox-cold welded to side panel; particularly designed for mechanically demanding environments (vibration resistance, applications requiring high levels of shock and vibration, e.g. IEC 61587-2)
- Heights: 3 and 6 U
Depths: 175, 235, 295 and 355 mm
Other dimensions on request
- 2 EMC shielding concepts for the front/rear: with stainless steel or textile EMC gasket
- Installed load up to 15 kg

Type L (light)

- Side panel with moulded 19" bracket, for standard applications, unshielded
- Particularly cost-effective version (not suitable for EMC applications)
- Heights: 3 and 6 U
Depths: 175, 235 and 295 mm
Other dimensions on request
- Installed load up to 7.5 kg

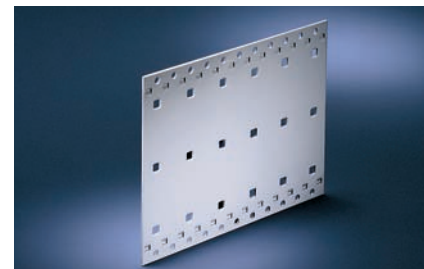

Subracks - *europac PRO* ServicePLUS

Side panels type F for stainless steel gasket

Order Information

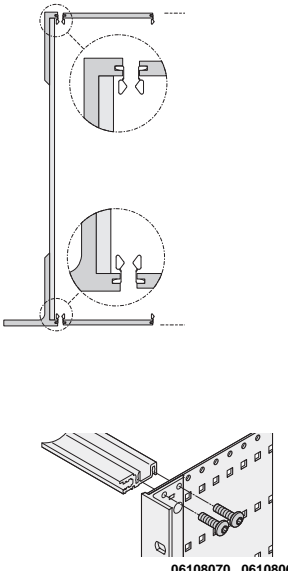
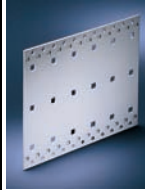
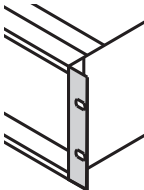
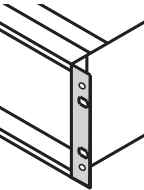
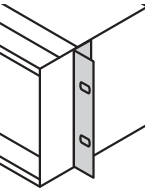
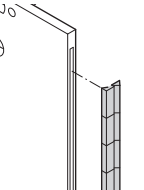
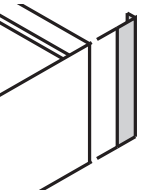
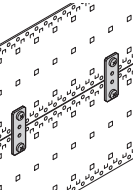
		 06197003 without 19" bracket, Al, 2 mm, passivated, please order 19" bracket and corner profile separately	 bza45819 with lateral grooves for stainless steel EMC gasket, Al extrusion, rear side etched, front anodised	 06106050 with lateral grooves for stainless steel EMC gasket, Al extrusion, rear side etched, front anodised please order front handles separately, see page 6.25	 06102501 Al extrusion, passivated	 BGA45760 inserted laterally into the grooves of the front panel	 BZA46573 Al extrusion, surface clear passivated; with lateral grooves for stainless steel EMC gasket; rear hood cannot be mounted simultaneously	 BPA45867 Zn die-cast, incl. fixing material kit, for connecting two by two side panels (on top of each other)
Height U	Depth mm	1 piece	PU 1 pair	PU 1 pair	PU 1 pair	PU 10 pieces	PU 1 pair	PU 4 pieces
3	175	34560-185						
3	235	34560-187						
3	275	34579-300 1)						
3	277.75	34579-002 2)						
3	295	34560-189	24560-197	24560-198	24560-199	21101-705	24561-198	21101-954
3	355	34560-191						
3	415	34560-193						
3	475	34560-195						
4	175	34560-285 3)						
4	235	34560-287 3)						
4	295	34560-289 3)	24560-297	24560-298	24560-299	21101-713	24561-298	21101-954
4	355	34560-291 3)						
4	415	34560-293 3)						
4	475	34560-295 3)						
6	175	34560-485						
6	235	34560-487						
6	275	34579-038 1)						
6	277.75	34579-012 2)						
6	295	34560-489	24560-497	24560-498	24560-499	21101-707	24561-498	21101-954
6	355	34560-491						
6	415	34560-493						
6	475	34560-495						
6	970	34560-496						
9	175	34560-785						
9	235	34560-787						
9	295	34560-789	24560-797	24560-798	24560-799	21101-709	24561-798	21101-954
9	355	34560-791						
9	415	34560-793						
Screw, M4 x 14, PU 100 pieces, for fastening horizontal rail to side panel		24560-130	24560-130	24560-130	24560-130	-	24560-130	-
Screw, M4 x 10, required if guide rails are screwed to slot 1, PU 100 pieces		24560-155	24560-155	24560-155	24560-155	-	24560-155	-



1) CompactPCI 2) VME64x 3) Grid holes of side panel 3 + 1 U

■ View of side panels 3, 4, 6, 9 U see page 6.18

Subracks - *europac* PRO ServicePLUS

Side panels type F for textile EMC gasket

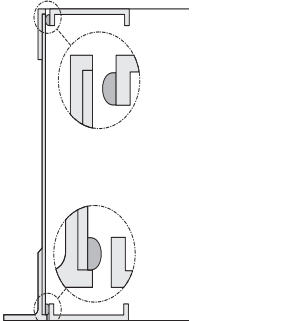
Order Information

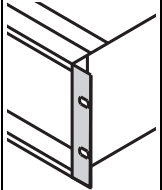
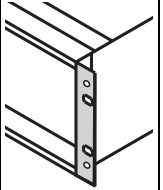
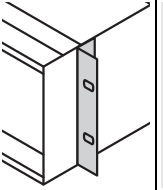
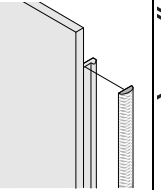
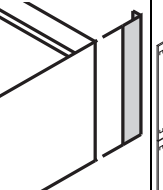
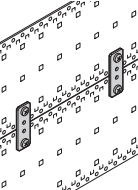
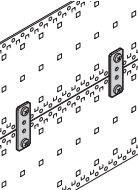

 <p>Illustration shows standard assembly, not VME or CompactPCI bus with rear I/O</p> 		 <p>06197003 without 19" bracket, Al, 2 mm, passivated, please order 19" bracket and corner profile separately</p>	 <p>bza45819 Al extrusion for textile EMC gasket rear side etched, front anodised</p>	 <p>06106950 Al extrusion for textile EMC gasket, rear side etched, front anodised, please order front handles separately, see page 6.25</p>	 <p>06102501 Al extrusion, passivated</p>	 <p>04602054 textile gasket, core: foam, sleeve: textile cladding with CuNi coating, UL 94 V-0</p>	 <p>BZA46573 Al extrusion, etched; for textile EMC gasket</p>	 <p>BPA45867 Zn die-cast, incl. fixing material kit, for connecting two by two side panels (on top of each other)</p>
Height U	Depth mm	1 piece	PU 1 pair	PU 1 pair	PU 1 pair	PU 10 pieces	PU 1 pair	PU 4 pieces
3	175	34560-185						
3	235	34560-187						
3	275	34579-300						
3	277.75	34579-002						
3	295	34560-189	24564-197	24564-198	24560-199	21101-853	24564-199	21101-954
3	355	34560-191						
3	415	34560-193						
3	475	34560-195						
4	175	34560-285						
4	235	34560-287						
4	295	34560-289	24564-297	24564-298	24560-299	21101-858	24564-299	21101-954
4	355	34560-291						
4	415	34560-293						
4	475	34560-295						
6	175	34560-485						
6	235	34560-487						
6	275	34579-038						
6	277.75	34579-012						
6	295	34560-489	24564-497	24564-498	24560-499	21101-855	24564-499	21101-954
6	355	34560-491						
6	415	34560-493						
6	475	34560-495						
6	970	34560-496						
9	175	34560-785						
9	235	34560-787						
9	295	34560-789	24564-797	24564-798	24560-799	21101-859	24564-799	21101-954
9	355	34560-791						
9	415	34560-793						
Screw, M4 x 14, PU 100 pieces, for fastening horizontal rail to side panel		24560-130	24560-130	24560-130	24560-130	-	24560-130	-
Screw, M4 x 10, required if guide rails are screwed to slot 1, PU 100 pieces		24560-155	24560-155	24560-155	24560-155	-	24560-155	-

1) CompactPCI 2) VME64x 3) Grid holes of side panel 3 + 1 U

Subracks - *europac PRO* ServicePLUS

Side panels type H for stainless steel EMC gasket

Order Information

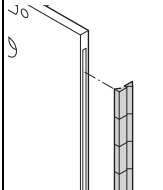
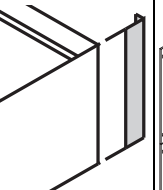
		Side panel type H for stainless steel EMC gasket without handle holes with handle holes		EMC gasket (stainless steel) 	Rear angle 	Side panel connection 
		for high mechanical demands, 19" bracket, tox-cold welded, Al, 2 mm, clear passivated, front anodised <small>06107004</small>	for high mechanical demands, 19" bracket, tox-cold welded, Al, 2 mm, clear passivated, front anodised, please order front handles separately see page 6.25 <small>06107001</small>	inserted laterally into the grooves of the front panel <small>BGA45760</small>	Al extrusion, surface clear passivated; with lateral grooves for stainless steel EMC gasket; rear hood cannot be mounted simultaneously <small>BZA46573</small>	Zn die-cast, incl. fixing material kit, for connecting two by two side panels (on top of each other) <small>BPA45867</small>
Height	Depth	PU 1 pair	PU 1 pair	PU 10 pieces	PU 1 pair	PU 4 pieces
U	mm					
3	175	24566-125	24567-125			
3	235	24566-127	24567-127			
3	275 1)	–	–			
3	277.75 2)	–	–	21101-705	24561-198	21101-954
3	295	24566-129	24567-129			
3	355	24566-131	24567-131			
3	415	–	–			
3	475	–	–			
4	175 3)					
4	235 3)					
4	295 3)	–	–	–	–	–
4	355 3)					
4	415 3)					
4	475 3)					
6	175	24566-425	24567-425			
6	235	24566-427	24567-427			
6	275 1)	–	–			
6	277.75 2)	–	–	21101-707	24561-498	21101-954
6	295	24566-429	24567-429			
6	355	24566-431	24567-431			
6	415	–	–			
6	475	–	–			
6	970	–	–			
9	175					
9	235					
9	295	–	–	–	–	–
9	355					
9	415					
Screw, M4 x 14, PU 100 pieces, for fastening horizontal rail to side panel		24560-130	24560-130	–	24560-130	–
Screw, M4 x 10, required if guide rails are screwed to slot 1, PU 100 pieces		24560-155	24560-155	–	24560-155	–

1) CompactPCI 2) VME64x 3) Grid holes of side panel 3 + 1 U

Side panels type H for textile EMC gasket

Order Information

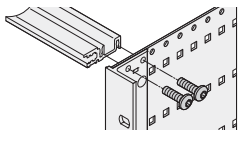

Illustration shows standard assembly, not VME or CompactPCI bus with rear I/O		Side panel type H for textile EMC gasket without handle holes	Side panel type H for textile EMC gasket with handle holes	EMC gasket (textile)	Rear angle	Side panel connection
		 06107001	 06107001	 04602054	 BZA46573	 BPA45867
Height		for high mechanical demands, 19" bracket, tox-cold welded, Al, 2 mm, clear passivated, front anodised	for high mechanical demands, 19" bracket, tox-cold welded, Al, 2 mm, clear passivated, front anodised, please order front handles separately see page 6.25	textile gasket, core: foam, sleeve: textile cladding with CuNi coating, UL 94 V-0	Al extrusion, etched; for textile EMC gasket	Zn die-cast, incl. fixing material kit, for connecting two by two side panels (on top of each other)
U	mm	PU 1 pair	PU 1 pair	PU 10 pieces	PU 1 pair	PU 4 pieces
3	175	24564-145	24566-145			
3	235	24564-147	24566-147			
3	275 1)	-	-			
3	277.75 2)	-	-			
3	295	24564-149	24566-149	21101-853	24564-199	21101-954
3	355	24564-151	24566-151			
3	415	-	-			
3	475	-	-			
4	175 3)					
4	235 3)					
4	295 3)	-	-	-	-	-
4	355 3)					
4	415 3)					
4	475 3)					
6	175	24564-445	24566-445			
6	235	24564-447	24566-447			
6	275 1)	-	-			
6	277.75 2)	-	-			
6	295	24564-449	24566-449	21101-855	24564-499	21101-954
6	355	24564-451	24566-451			
6	415	-	-			
6	475	-	-			
6	970	-	-			
9	175					
9	235					
9	295	-	-	-	-	-
9	355					
9	415					
Screw, M4 x 14, PU 100 pieces, for fastening horizontal rail to side panel		24560-130	24560-130	-	24560-130	-
Screw, M4 x 10, required if guide rails are screwed to slot 1, PU 100 pieces		24560-155	24560-155	-	24560-155	-

1) CompactPCI 2) VME64x 3) Grid holes of side panel 3 + 1 U

Subracks - *europac PRO* ServicePLUS

Side panels type L

Order Information

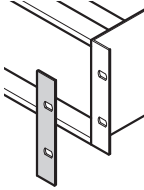
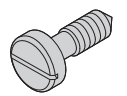
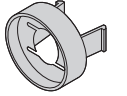
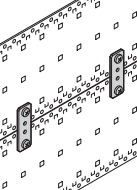
		 06197002 Al, 2 mm, passivated	 BZA45810 for decorative finish of 19" bracket, Al, 2 mm, anodised	 06708055 M6 x 16, St, nickel-plated	 00508056 PPE, black	 BPA45867 Zn die-cast, incl. fixing material kit, for connecting two by two side panels (on top of each other)
Height U	Depth mm	1 piece		PU 100 pieces	PU 100 pieces	PU 4 pieces
3	175	34561-185				
3	235	34561-187				
3	275 1)	-				
3	277.75 2)	-				
3	295	34561-189	34561-197	21100-565	21100-566	21101-954
3	355	-				
3	415	-				
3	475	-				
4	175 3)					
4	235 3)					
4	295 3)	-				
4	355 3)	-				
4	415 3)	-				
4	475 3)	-				
6	175	34561-485				
6	235	34561-487				
6	275 1)	-				
6	277.75 2)	-				
6	295	34561-489	34561-497	21100-565	21100-566	21101-954
6	355	-				
6	415	-				
6	475	-				
6	970	-				
9	175					
9	235					
9	295	-				
9	355	-				
9	415	-				
Screw, M4 x 14, PU 100 pieces, for fastening horizontal rail to side panel		24560-130	-	-	-	-
Screw, M4 x 10, required if guide rails are screwed to slot 1, PU 100 pieces		24560-155	-	-	-	-

1) CompactPCI 2) VME64x 3) Grid holes of side panel 3 + 1 U

Subracks - *europac* **PRO** ServicePLUS

Front handles, wall-mounting brackets

Order Information

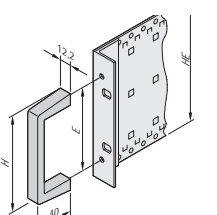
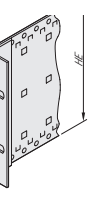
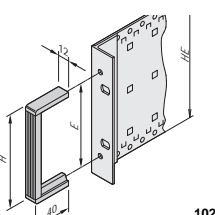
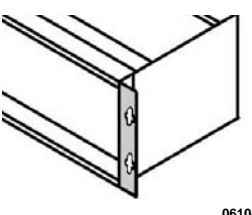
Height U	Depth mm	H mm	E mm	Front handle		Universal front handle	Wall-mounting bracket
				clear anodised	black anodised		
							
				Al extrusion, anodised load-carrying capacity 30 kg	06102068	3 parts: Al extrusion, clear anodised, 2 end pieces, plastic, PA, black; width 12 mm, depth 40 mm load-carrying capacity 10 kg	06104063
				1 piece (SPQ 10)¹⁾	1 piece (SPQ 10)¹⁾	1 piece (SPQ 10)¹⁾	PU 1 pair
3	175	102	88.0	10501-005	10501-026	10502-057	24562-197
3	235	102	88.0				
3	275	102	88.0				
3	277.75	102	88.0				
3	295	102	88.0				
3	355	102	88.0				
3	415	102	88.0	10501-018	-	10502-060	24562-297
3	475	102	88.0				
4	175	146	133.4				
4	235	146	133.4				
4	295	146	133.4				
4	355	146	133.4				
4	415	146	133.4	10501-008	10501-029	10502-065	24562-497
4	475	146	133.4				
6	175	249	235.0				
6	235	249	235.0				
6	275	249	235.0				
6	277.75	249	235.0				
6	295	249	235.0	10501-008	10501-029	10502-065	24562-797
6	355	249	235.0				
6	415	249	235.0				
6	475	249	235.0				
6	970	249	235.0				
9	175	249	235.0				
9	235	249	235.0	24560-183	24560-183	24560-183	-
9	295	249	235.0				
9	355	249	235.0				
9	415	249	235.0				
9	415	249	235.0				
Screw M5 x 12, PU 100 pieces				24560-183	24560-183	24560-183	-
Screw M5 x 12, PU 4 pieces				24560-182	24560-182	24560-182	-
Screw, M4 x 14, PU 100 pieces				-	-	-	24560-130

1) SPQ (standard pack quantity): Part number includes 1 piece, but delivery is exclusively made in standard pack quantity (SPQ); please order at least the SPQ quantity or a multiple

Horizontal rails



- Aluminium profile, surface anodised, conductive contact surfaces for EMC gaskets
- The horizontal rail is marked with sequential numbering (for sizes > 28 HP) to facilitate positioning of the guide rails
- Horizontal rails are fixed to the side panel using M4 bolts with torx 20 drive
- There are 3 different horizontal rails for different loading levels
 - light, for up to 7.5 kg
 - heavy, for 7.5 kg to 15 kg
 - rugged, for 15 kg to approx. 60 kg

Mounting position of the horizontal rails

PCB as deep as side panel

Cabling space behind backplane

Rear I/O installation
(CompactPCI, VME64x applications)

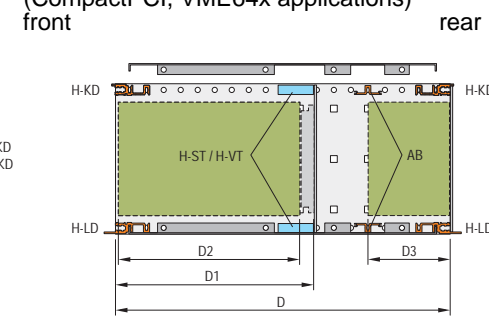
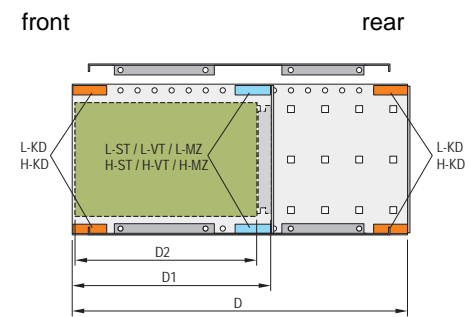
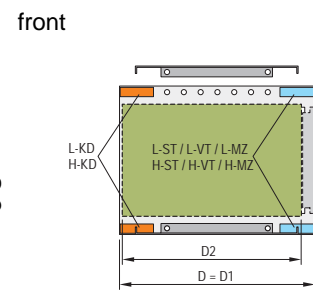

160, 220, 280 mm,

160, 220, 280 mm,

160 mm/80 mm

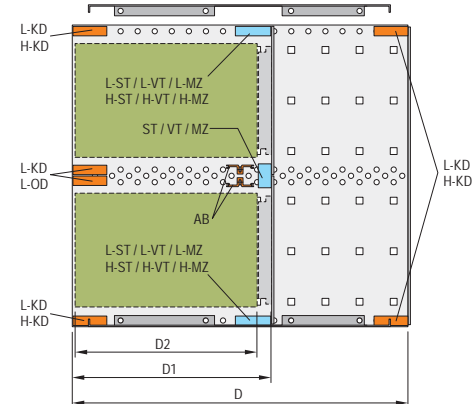
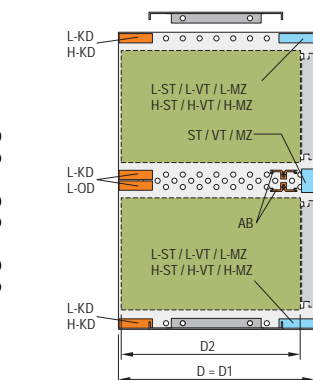

160, 220, 280 mm,

160, 220, 280 mm,

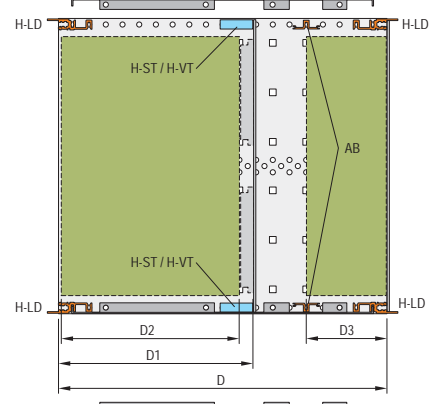
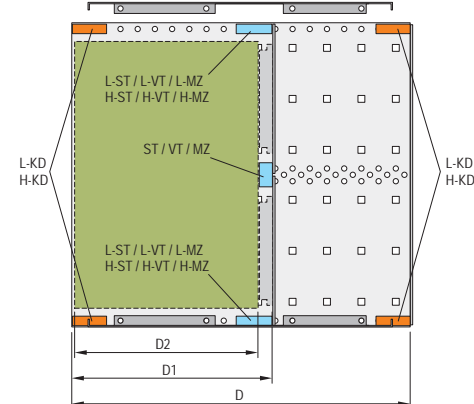
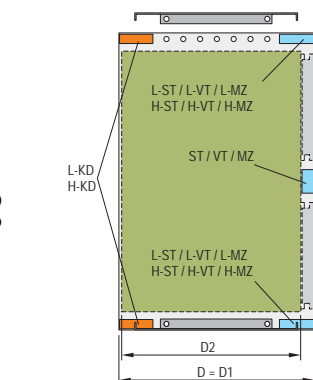

160, 220, 280 mm,

160, 220, 280 mm,

160 mm/80 mm

Front horizontal rails

Assembly 3 U, 2 x 3 U, 6 U

"light" (L)

"heavy" (H)

"heavy" (H)



06197007

06197008

06197009

Short lip

Short lip

Long lip

3 U/6 U

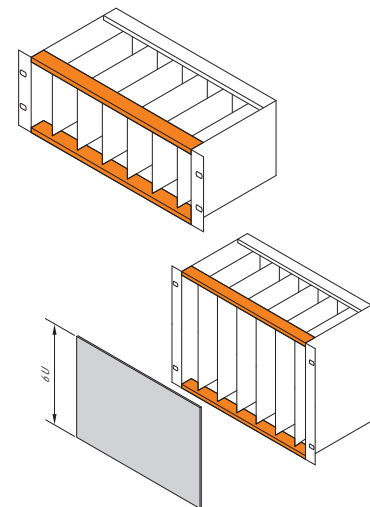

bza44980 bza44974

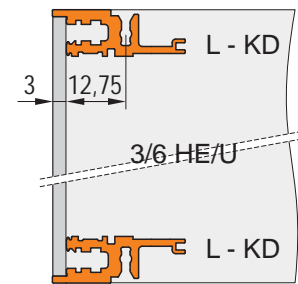

06105060

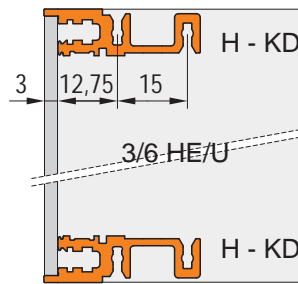

06105061

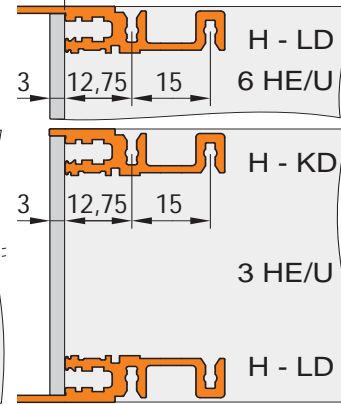

06108063

2 x 3 U

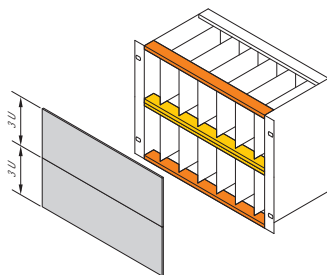

bza44972

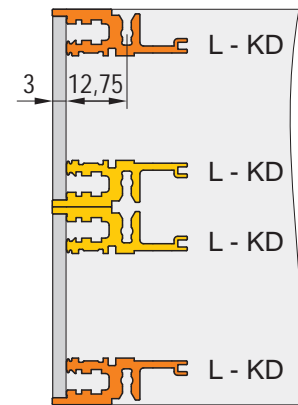

06105062

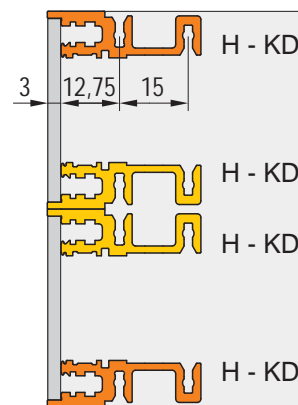

06105063

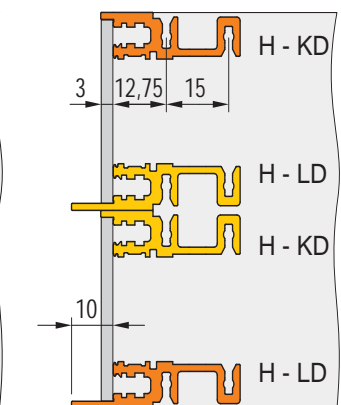

06108064

2 x 3 U, 6 U

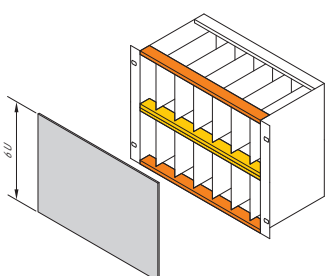

06105059

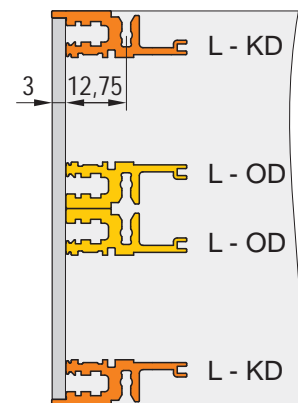

06105064

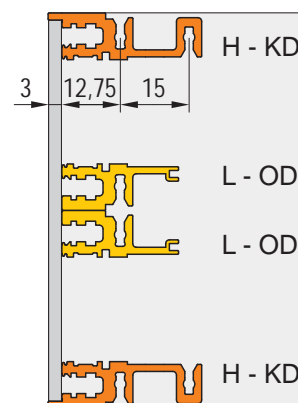

06105065

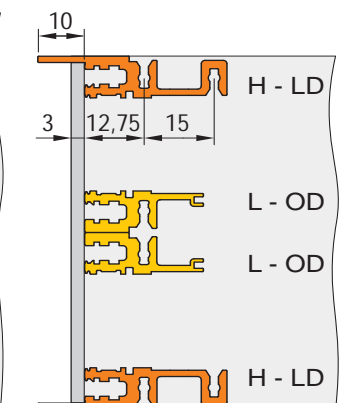

06108065

L-OD = Light - without lip, L-KD = Light - short lip, H-KD = Heavy - short lip, H-LD = Heavy - long lip

Front horizontal rails

Order Information

Usable length HP		Length mm	"light" Type L-OD without lip	"light" Type L-KD short lip	"heavy" Type H-KD short lip	With long lip for insertion/extraction of CompactPCI and VME64x boards "heavy" Type H-LD long lip
With HP markings from 28 HP, Al extrusion, anodised finish, conductive contact surface			Al extrusion, anodised finish, conductive contact surface, with printed HP markings without lip: 2 x 3 U installation and continuous 6 U front panel	Al extrusion, anodised finish, conductive contact surface, with printed HP markings short lip: horizontal rail and front panel form a single plane	Al extrusion, anodised finish, conductive contact surface, with printed HP markings short lip: horizontal rail and front panel form a single plane	Al extrusion, anodised finish, conductive contact surface, with printed HP markings long lip: for insertion/extraction of CompactPCI or VME64x boards
			1 piece (SPQ 10)¹⁾	1 piece (SPQ 10)¹⁾	1 piece (SPQ 10)¹⁾	1 piece (SPQ 10)¹⁾
20	106.68		34560-020	34560-120	34560-220	34560-320
28	147.32		34560-028	34560-128	34560-228	34560-328
40	208.28		34560-040	34560-140	34560-240	34560-340
42	218.44		34560-042	34560-142	34560-242	34560-342
63	325.12		34560-063	34560-163	34560-263	34560-363
84	431.80		34560-084	34560-184	34560-284	34560-384
—	1000		34560-001	34560-101	34560-201	34560-301
Screw, M4 x 14, PU 100 pieces			24560-130	24560-130	24560-130	24560-130
Screw, M4 x 10, required if guide rails are screwed to slot 1, PU 100 pieces			—	—	24560-155	24560-155
Threaded inserts see page			6.33	6.33	6.33	6.33

1) SPQ (standard pack quantity): Part number includes 1 piece, but delivery is exclusively made in standard pack quantity (SPQ); please order at least the SPQ quantity or a multiple
"light": loading capacity up to approx. 7.5 kg; "heavy": loading capacity > 7.5 kg

Note

- 1000 mm version without M4 thread to front, without printed markings and without notch for 19"-bracket
- Rugged horizontal rails with 3 fixing holes see section "Rugged Subracks", page 6.99

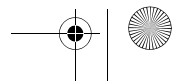
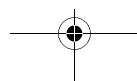
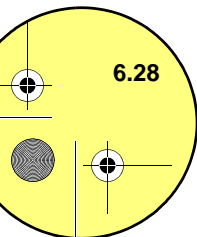

Rear horizontal rails

Indirect backplane mounting
(with insulation strip)



04400001

Direct backplane mounting

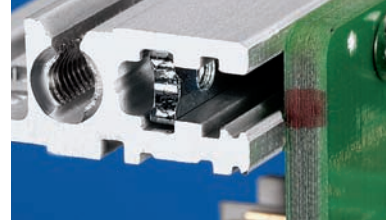

04400002

Connector fitting with Z



04400003

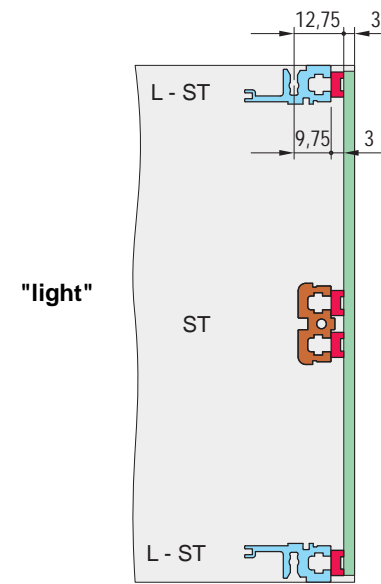

06105072

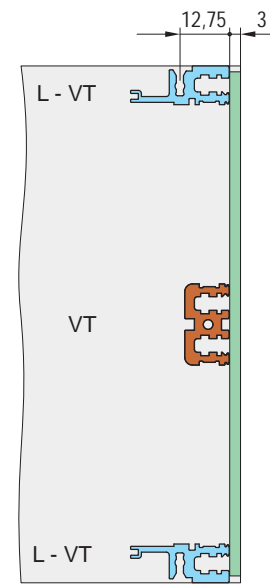

06105073

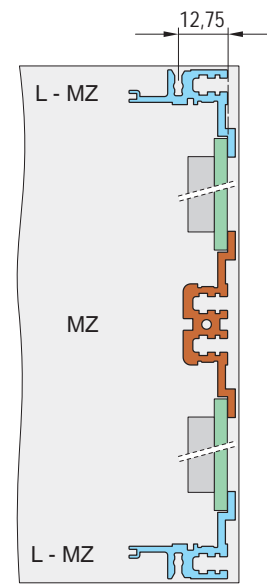

06105071

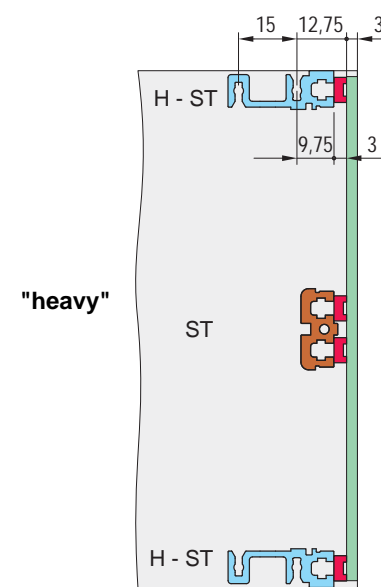

06108066

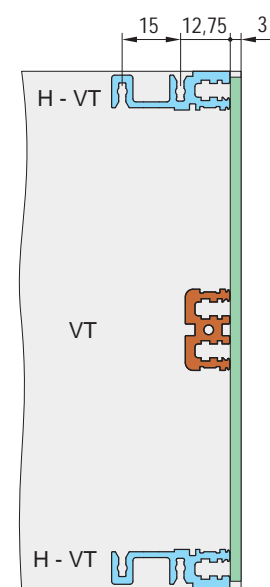

06108067

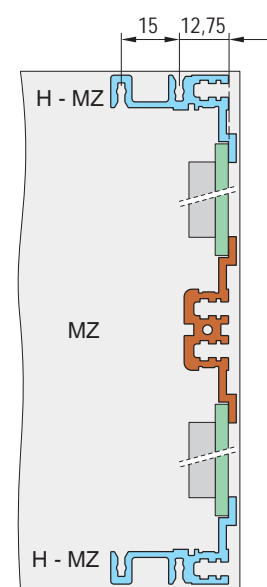

06108068

ST = standard, L = light, H = heavy

VT = depth-offset, L = light, H = heavy

MZ = with Z-rail, L = light, H = heavy

Order Information

Usable length HP	Length mm	For indirect backplane mounting with insulation strip		For direct backplane mounting		For direct fixing of connectors in accordance with EN 60603-2 (DIN 41612)	
		"light" Type L-ST standard	"heavy" Type H-ST standard	"light" Type L-VT + 3 mm	"heavy" Type H-VT + 3 mm	"light" Type L-MZ with Z-rail	"heavy" Type H-MZ with Z-rail
		06197011	06197011	06197011	06197011	06197011	06197011
		06197010	06197011	BZA45782	06197009	06197014	06197015
		06105074					
		With HP markings from 28 HP, Al extrusion, anodised finish, conductive surface		Al extrusion, anodised surface, conductive contact surface, with printed HP markings		Al extrusion, anodised surface, conductive contact surface, with printed HP markings	
		1 piece (SPQ 10) ¹⁾	1 piece (SPQ 10) ¹⁾	1 piece (SPQ 10) ¹⁾	1 piece (SPQ 10) ¹⁾	1 piece (SPQ 10) ¹⁾	1 piece (SPQ 10) ¹⁾
20	106.68	34560-420	34560-520	34560-620	34560-720	34560-820	34560-920
28	147.32	34560-428	34560-528	34560-628	34560-728	34560-828	34560-928
40	208.28	34560-440	34560-540	34560-640	34560-740	34560-840	34560-940
42	218.44	34560-442	34560-542	34560-642	34560-742	34560-842	34560-942
63	325.12	34560-463	34560-563	34560-663	34560-763	34560-863	34560-963
84	431.80	34560-484	34560-584	34560-684	34560-784	34560-884	34560-984
—	1000	34560-401	34560-501	34560-601	34560-701	34560-801	—
Screw, M4 x 14, PU 100 pieces, for fastening horizontal rail to side panel		24560-130	24560-130	24560-130	24560-130	24560-130	24560-130
Screw, M4 x 10, required if guide rails are screwed to slot 1, PU 100 pieces		—	24560-155	—	24560-155	—	24560-155
Perforated rail for connector mounting with insulation strip see page		6.34	6.34	—	—	—	—
Z-rail for connector mounting without insulation strip see page		6.34	6.34	—	—	—	—
Insulation strips see page		6.33	6.33	—	—	—	—
Threaded inserts see page		6.33	6.33	6.33	6.33	6.33	6.33

1) SPQ (standard pack quantity): Part number includes 1 piece, but delivery is exclusively made in standard pack quantity (SPQ); please order at least the SPQ quantity or a multiple







"light": loading capacity up to approx. 7.5 kg; "heavy": loading capacity > 7.5 kg

Note

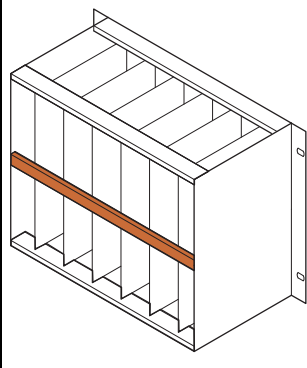
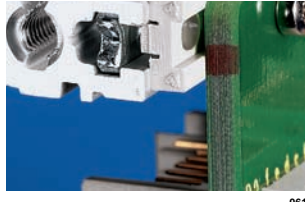
- 1000 mm version without M4 thread to front, without printed markings and without notch for 19"-bracket
- Rugged horizontal rails with 3 fixing holes see section "Rugged Subracks", page 6.99

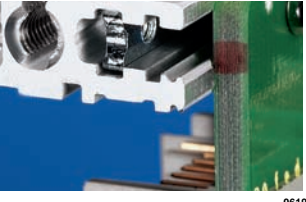
Part number in bold face type: ready for despatch within 2 working days
Part number in normal type: ready for despatch within 10 working days

Order Information

		For indirect backplane mounting with insulation strip	For direct backplane mounting	For direct fixing of connectors in accordance with EN 60603-2 (DIN 41612)
		 <p>Type ST</p>  <p>Al extrusion, anodised surface, conductive contact surface, without printed markings</p>	 <p>Type VT</p>  <p>Al extrusion, anodised surface, conductive contact surface, without printed markings</p>	 <p>Type MZ</p>  <p>Al extrusion, anodised surface, conductive contact surface, without printed markings</p>
Usable length HP	Length mm	1 piece (SPQ 10)¹⁾	1 piece (SPQ 10)¹⁾	1 piece (SPQ 10)¹⁾
20	106.68	34561-020	34561-120	34561-220
28	147.32	34561-028	34561-128	34561-228
40	208.28	34561-040	34561-140	34561-240
42	218.44	34561-042	34561-142	34561-242
63	325.12	34561-063	34561-163	34561-263
84	431.80	34561-084	34561-184	34561-284
-	1000	34561-001	34561-101	34561-201
Screw, M4 x 14, PU 100 pieces, for fastening horizontal rail to side panel		24560-130	24560-130	24560-130
Insulation strips see page		6.33	-	-
Threaded inserts see page		6.33	6.33	6.33

1) SPQ (standard pack quantity): Part number includes 1 piece, but delivery is exclusively made in standard pack quantity (SPQ); please order at least the SPQ quantity or a multiple
"light": loading capacity up to approx. 7.5 kg; "heavy": loading capacity > 7.5 kg

Note

- All horizontal rails without printed markings
- 1000 mm version without M4 thread to front

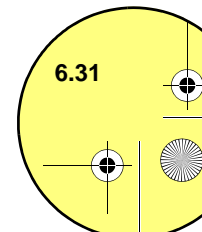

Order Information

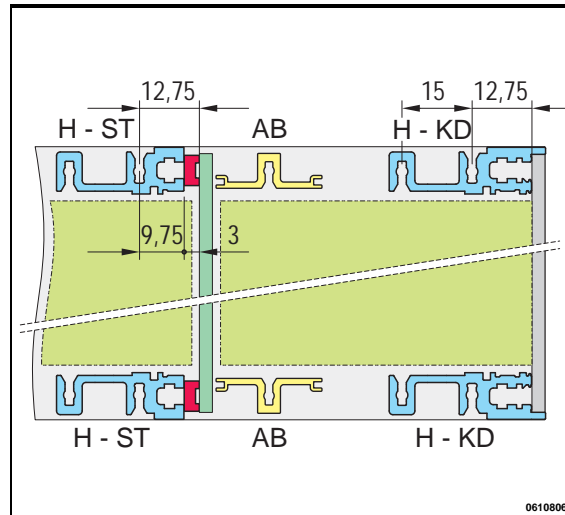

For CompactPCI in rear I/O area



06108069

Type AB



06197009

Al extrusion, anodised surface, conductive contact surface; horizontal rail type AB (AB = support) is required to fix the 80 mm rear I/O boards; without printed markings

1 piece (SPQ 10)¹⁾

Usable length HP	Length mm	
20	106.68	34561-520
28	147.32	34561-528
40	208.28	34561-540
42	218.44	34561-542
63	325.12	34561-563
84	431.80	34561-584
—	1000	34561-501
Screw, M4 x 14, PU 100 pieces, for fastening horizontal rail to side panel		24560-130

1) SPQ (standard pack quantity): Part number includes 1 piece, but delivery is exclusively made in standard pack quantity (SPQ); please order at least the SPQ quantity or a multiple
"light": loading capacity up to approx. 7.5 kg; "heavy": loading capacity > 7.5 kg

Note

- All horizontal rails without printed markings
- 1000 mm version without M4 thread to front

Order Information

Usable length HP	Threaded insert		Perforated strip (item 1)		Insulation strip	
	Length mm	1 piece (SPQ 10) ¹⁾	1 piece (SPQ 10) ¹⁾	Length mm	1 piece (SPQ 10) ¹⁾	Length mm
20	106.18	34561-320	–	106.48	30845-189	101.50
28	146.82	34561-328	–	147.12	30845-197	144.20
40	207.78	34561-340	–	208.08	30845-209	205.12
42	217.94	34561-342	–	218.24	30845-211	210.40
63	324.62	34561-363	–	324.92	30845-232	316.88
84	431.30	34561-384	34561-484	431.60	30845-253	428.64
196	1000.26	34565-196	–	1000.56	34565-396	–

Accessories

Grub screw M2.5 x 8, PU 100 pieces	21100-276	–	–	–	–	–
Grub screw M2.5 x 9, PU 100 pieces	–	–	–	21101-359	–	–
Grub screw M3 x 8, PU 100 pieces	–	21100-646	–	–	–	–

1) SPQ (standard pack quantity): Part number includes 1 piece, but delivery is exclusively made in standard pack quantity (SPQ); please order at least the SPQ quantity or a multiple

2) Part no. includes one packing unit (PU); delivery is exclusively made in PU

Order Information

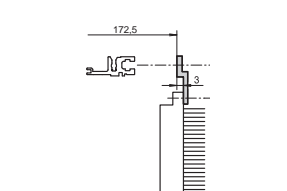
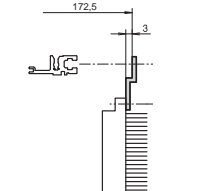
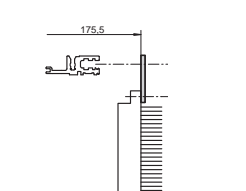
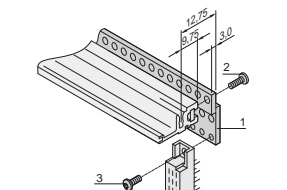
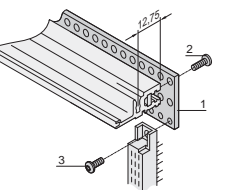
		Z-rail for connectors DIN EN 60603-2, DIN 41612 item 1		31-pin, DIN 41617	Perforated rail EN 606032, DIN 41612 item 1
					
					
		for connector mounting on ST horizontal rails, please order threaded inserts and screw separately		for connector mounting on ST horizontal rails, please order threaded inserts and screw separately	for connector mounting on VT horizontal rails, please order threaded inserts and screw separately
Usable length	Length	1 piece		1 piece	PU 4 pieces
HP	mm				
20	101.60	30822-025		—	20822-051
28	142.24	30822-033		—	20822-049
40	203.20	30822-045		30819-763	20822-046
42	213.36	30822-047		—	20822-050
60	304.80	30822-065		30819-783	20822-047
84	426.72	30822-089		30819-808	20822-048
Item 3, torx panhead screw to fix connector to perforated rail., M2.5 x 7, PU 100 pieces		24560-147		24560-147	24560-147
Item 2, torx panhead screw, to fix perforated rails to horizontal rail, M2.5 x 10, PU 100 pieces		24560-148		24560-148	24560-148

Guide rails

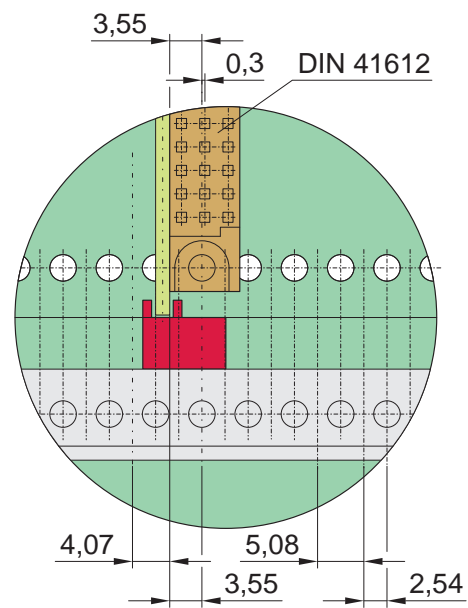

Guide rails form the interface between the subrack mechanics and the sub-assemblies (PCBs, plug-in units, frame-type plug-in units, ...).

Guide rails for standard applications are 2 HP wide. Guide rails with coding (e.g. for CompactPCI or VME64bus applications) are 4 HP wide.

There are groove widths of 2 mm and 2.5 mm.

The guide rails are clipped into the rectangular cut-outs of the horizontal rails. They can additionally be bolted to the horizontal rail (type H only) for higher shock and vibration requirements.

The printed HP markings on the horizontal rail (28 HP and above) allow the rails to be fitted in the correct position easily (position of sub-assembly = "number in viewing window" or in front of the arrow marking on the guide rails).

Front view: position of guide rails to connector (EN 60603-2/
DIN 41612) 06108083

Applications for guide rails

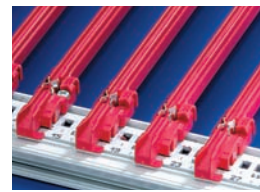

For plug-in units and frame-type plug-in units (with front panels)
(standard type)

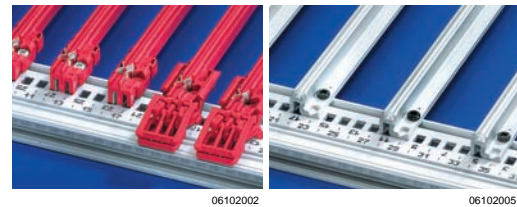

For plug-in units and frame type plug-in units or
for PCBs without their own front panel
(accessory type or robust version)

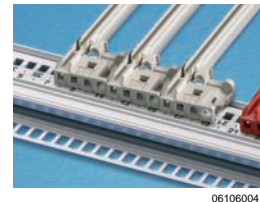

For CompactPCI or VME64x plug-in units
(type IEEE with coding; frame-type plug-in units cannot be fitted)



For plug-in drive unit modules or PCBs in 4.4" (111.7 mm) height
(type 4.4")



Rugged guide rails to accommodate conduction cooled assembly (CCA)
adaptor

Accessories:

- ESD clip
- Keying/coding pegs
- Board locking

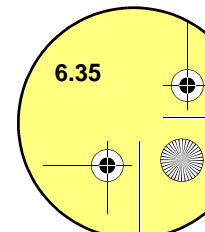

Subracks - *europac PRO* ServicePLUS

Guide rails for plug-in units and modules, one-piece, groove width 2 mm and 2.5 mm

Order Information

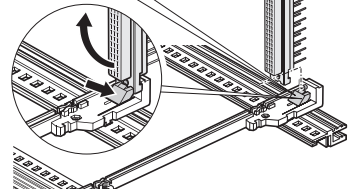
Assembly			For plug-in units and frame type plug-in units standard type		standard type, with DIN connector fixing
- can be clipped into Al extruded horizontal rails - can be clipped into 1.5 mm thick plates Storage temperature from -40 °C ... 130 °C			 up to 220 mm length, PBT, UL 94 V-0; from 280 mm length, multi-piece, end piece PBT, UL 94 V-0, central section Al extrusion		 PBT, UL 94 V-0, red, connector is clipped directly onto the guide rails; for euroboards only, 100 x 160 mm or 100 x 220 mm
Board length mm	Groove width mm	Colour mm	PU 10 pieces ²⁾	1 piece (SPQ 50) ¹⁾	1 pair (SPQ 10) ¹⁾
70	2	red	–	34579-230	–
70	2	grey	–	34579-231	–
160	2	red	24560-351	64560-001	64560-074
220	2	red	24560-353	64560-002	64560-075
280	2	red	24560-379	–	–
340	2	red	24560-380	–	–
160	2.5	red	–	64560-096	–
220	2.5	red	–	64560-098	–

Accessories

Retention screw, PU 100 pieces; Torque max. 0.2 Nm	24560-141	–	24560-141
ESD clip, PU 50 pieces	24560-255	–	24560-255

1) SPQ (standard pack quantity): Part number includes 1 piece, but delivery is exclusively made in standard pack quantity (SPQ); please order at least the SPQ quantity or a multiple

2) Part no. includes one packing unit (PU); delivery is exclusively made in PU

Description of accessories see from page 6.41

Subracks - *europac* **PRO** ServicePLUS

Guide rails type "accessory", one-piece,
groove width 2 mm and 2.5 mm

Order Information

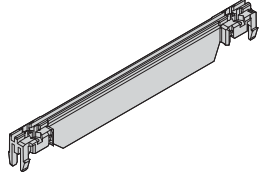
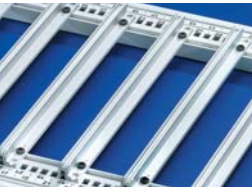
Board length mm	Groove width mm	Colour	Guide rails			
			accessory type	accessory type, strengthened	for heavy modules, Al extrusion, silver, robust version	
			 <p>up to 280 mm length, PBT, UL 94 V-0; > 280 mm length, multi-piece, end piece PBT, UL 94 V-0, middle section Al extrusion</p>	 <p>PBT UL 94 V-0, red; support beam of guide rails adds to strengthening</p>	 <p>Al extrusion; is screwed to horizontal rail "heavy" with retention screws</p>	
			PU 10 pieces²⁾	1 piece (SPQ 50)	1 piece (SPQ 50)	1 piece (SPQ 10)¹⁾
100	2	red	–	64560-082	–	–
160	2	red	24560-373	64560-005	64560-076	–
160	2	grey/silver	–	64560-055	–	34562-881
220	2	red	24560-374	64560-006	64560-078	–
220	2	grey/silver	–	64560-166	–	34562-882
280	2	red/silver	24560-375	–	64560-080	34562-883
340	2	red/silver	24560-376	–	–	34562-884
400	2	red/silver	–	–	–	34562-885
160	2.5	silver	–	–	–	34564-881
220	2.5	silver	–	–	–	34564-882
280	2.5	silver	–	–	–	34564-883
340	2.5	silver	–	–	–	34564-884
400	2.5	silver	–	–	–	34564-885

Accessories

Retention screw, PU 100 pieces; torque max. 0.2 Nm 	24560-141	24560-141	24560-141	24560-157
ESD clip, PU 50 pieces	24560-255	24560-255	24560-255	–
Board locking, red, PU 10 pieces	24560-377	24560-377	24560-377	–
Board handle, red, PU 10 pieces	24560-378	24560-378	24560-378	–
Identification strips for board handle, red, PU 1 sheet = 438 pieces	60817-228	60817-228	60817-228	–
Coding see page		6.41		–

1) SPQ (standard pack quantity): Part number includes 1 piece, but delivery is exclusively made in standard pack quantity (SPQ); please order at least the SPQ quantity or a multiple



2) Part no. includes one packing unit (PU); delivery is exclusively made in PU

Description of accessories see from page 6.41

Subracks - *europac PRO* ServicePLUS

Guide rails for CompactPCI, VME64x with coding,
4.4" PCBs, groove width 2 mm and 2.5 mm

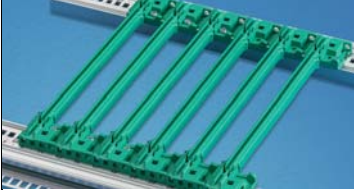
Order Information

Assembly			For CompactPCI, VME64x with coding In accordance with IEEE 1101.10 and IEC 60297-3-103		Offset 0.1" for power supply units in accordance with IEEE 1101.10 and IEC 60297-3-103		For 4.4" PCBs	
- can be clipped into Al extruded horizontal rails - can be clipped into 1.5 mm thick plates								
Storage temperature from -40 °C ... 130 °C			06106001 04611009		06106002		06104009	
			One-piece for groove width 2 mm, PBT, UL 94 V-0; multi-piece at groove width 2,5 mm, end-piece PBT, UL 94 V-0, center piece Al		PBT, UL 94 V-0 PBT, UL 94 V-0, for installation of power supplies in CompactPCI systems or plug-in units with SMD placement		One-piece, PBT, UL 94 V-0; for 4.4" PCBs or drive unit modules	
Board length mm	Groove width mm	Colour mm	PU 10 pieces	1 piece (SPQ 50) ¹⁾	PU 10 pieces	1 piece (SPQ 50) ¹⁾	PU 10 pieces	1 piece (SPQ 50) ¹⁾
70	2	red	24560-355	64560-085	–	–	–	–
70	2	grey	24560-360	64560-086	–	–	–	–
160	2	red	24560-356	64560-089	–	–	24560-361	64560-143
160	2	grey	24560-358	64560-090	–	–	–	–
160	2	green	–	–	24560-359	64560-071	–	–
220	2	red	–	64560-091	–	–	24560-362	64560-144
220	2	grey	–	64560-092	–	–	–	–
220	2	green	–	–	–	64560-072	–	–
160	2.5	red	–	–	–	–	–	64560-145
220	2.5	red	24561-330	–	–	–	–	64560-146
220	2.5	grey	24561-340	–	–	–	–	–
280	2.5	red	24561-331	–	–	–	–	–
280	2.5	grey	24561-341	–	–	–	–	–
340	2.5	red	24561-332	–	–	–	–	–
340	2.5	grey	24561-342	–	–	–	–	–

Accessories

ESD clip, PU 50 pieces	24560-255	24560-255	–	–	–	–
ESD clips, for alignment pin, PU 50 pieces	24560-256	24560-256	24560-256	24560-256	–	–
Retention screw, PU 100 pieces; torque max. 0.2 Nm	24560-141	24560-141	24560-141	24560-141	24560-158	24560-158
Coding peg, PU 100 pieces	20817-501	20817-501	20817-501	20817-501	–	–

1) SPQ (standard pack quantity): Part number includes 1 piece, but delivery is exclusively made in standard pack quantity (SPQ); please order at least the SPQ quantity or a multiple

2) Part no. includes one packing unit (PU); delivery is exclusively made in PU

Description of accessories see from page 6.41

Order Information

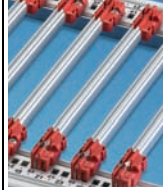
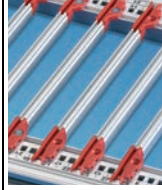
<p>PCBs: Fixed lengths for 160, 220, 280, 340 mm; length 1000 mm for special dimensions</p> <p>Mounting: pluggable into horizontal rails</p> <p>Storage temperature : End piece -40°C ... +130°C PVC profile 0°C ... +60°C</p>		<p>For plug-in units and modules standard type</p>  <p>06106004</p> <p>end piece, PBT, UL 94 V-0, middle section Al extrusion</p>		<p>Accessories type</p>  <p>06106005</p> <p>end piece, PBT, UL 94 V-0, middle section Al extrusion</p>		<p>For 4.4" PCBs</p>  <p>06106006</p> <p>end piece, PBT, UL 94 V-0, middle section Al extrusion</p>		<p>end piece, PBT, UL 94 V-0, middle section plastic extrusion (PVC, RAL 7035)</p>	
Description	Length mm	Groove width mm	1 piece (SPQ 10)¹⁾	1 piece (SPQ 10)¹⁾	1 piece (SPQ 10)¹⁾	1 piece (SPQ 10)¹⁾	1 piece (SPQ 10)¹⁾	1 piece (SPQ 10)¹⁾	
End piece, red, 1 pair	2		64560-004	64560-004	64560-008	64560-008	64560-057	64560-057	
Al extrusion, for 160 mm board length	95	2	34560-891	34564-891	34560-891	34564-891	34560-891	34564-891	
Al extrusion, for 220 mm board length	155	2	34560-892	34564-892	34560-892	34564-892	34560-892	34564-892	
Al extrusion, for 280 mm board length	215	2	34560-893	34564-893	34560-893	34564-893	34560-893	34564-893	
Al extrusion, for 340 mm board length	275	2	34560-894	—	34560-894	—	34560-894	—	
Al extrusion, for any board length	1000	2	34560-900	—	34560-900	—	34560-900	—	
Plastic extrusion, for any board length	1000	2	—	34564-900	—	34564-900	—	34564-900	

Accessories

ESD clip, PU 50 pieces	24560-255	24560-255	24560-255	24560-255	—	—
Retention screw, PU 100 pieces; torque max. 0.2 Nm	24560-141	24560-141	24560-141	24560-141	24560-158	24560-158
Board locking, red, PU 10 pieces	—	—	24560-377	24560-377	—	—
Board handle, red, PU 10 pieces	—	—	24560-378	24560-378	—	—
Identification strips for board handle, red, PU 1 sheet = 438 pieces	—	—	60817-228	60817-228	—	—
Coding see page	—	—	see page 6.41		—	—

1) SPQ (standard pack quantity): Part number includes 1 piece, but delivery is exclusively made in standard pack quantity (SPQ); please order at least the SPQ quantity or a multiple

2) Part no. includes one packing unit (PU); delivery is exclusively made in PU

Description of accessories see from page 6.41

Note

- Strengthening for middle section (plastic extrusion) available on request

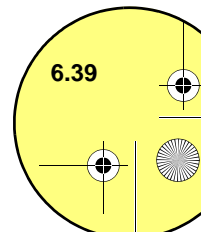

Dimension drawings of guide rails

Standard

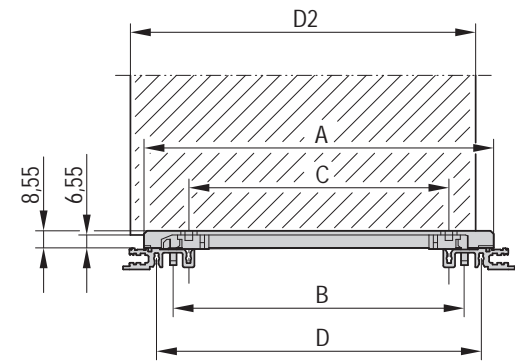

bza45808

Robust version

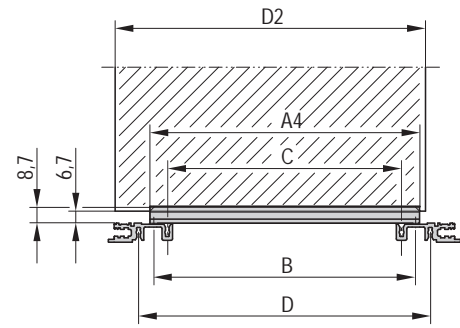

06105074

For accessories

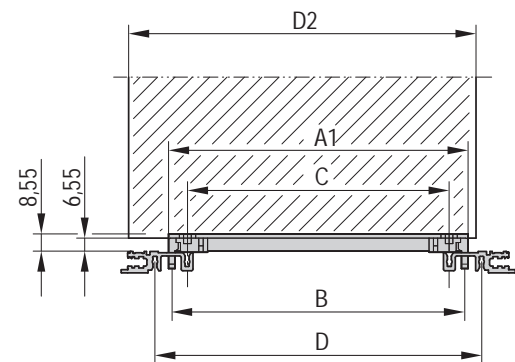

bza45808

For accessories, strengthened

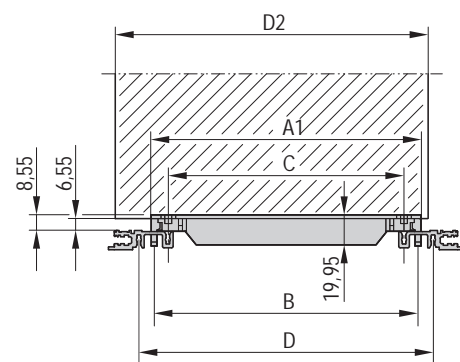

bza46552

CompactPCI, VME64x

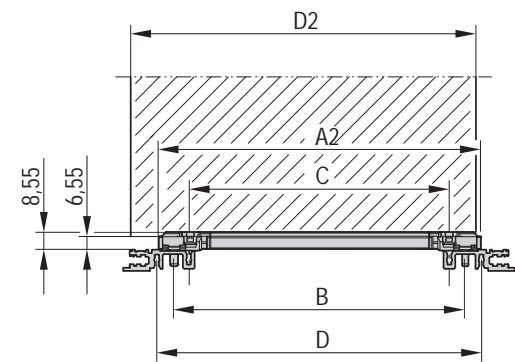

06105068

4.4" (111.7 mm)

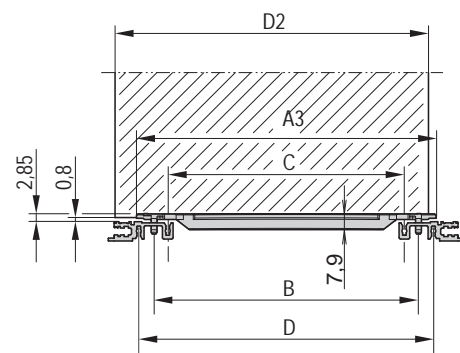

06105069

Dimensions table

Board length L	Dimensions								
	A	A1	A2	A3	A4	B	C	D	
mm	mm	mm	mm	mm	mm	mm	mm	mm	
70	71.5	47.9	59.39	63	49	45	30	60	
100	101.5	77.9	89.39	93	79	75	60	90	
160	161.5	137.9	149.39	153	139	135	120	150	
220	221.5	197.9	209.39	213	199	195	180	210	
280	281.5	257.9	269.39	273	259	255	240	270	
340	341.5	317.9	322.39	333	319	315	300	330	
400	401.5	377.9	389.39	393	379	375	360	390	

A, A1, A2, A3, A4: Length of rail

B: Pitch of snap-in fixing

C: Pitch of guide rail retention screws

D: Pitch of horizontal rail retention screws

Guide rail accessories

Order Information

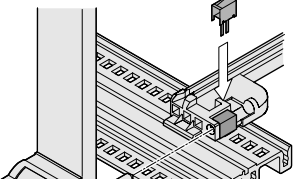
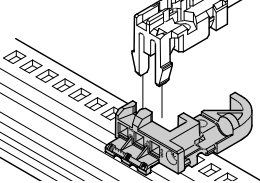
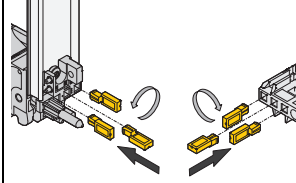
		ESD clips, CompactPCI/VME 64 alignment pin for guide rails	Coding for subracks	
		 06103052	Keying/coding block for guide rails accessory type  06103051	Keying/coding for CompactPCI, VME64x handles to IEEE 1011.10 and IEC 60297-3-103  04612052
		Spring steel, tin-plated, ESD clip, for alignment pin in accordance with IEEE; can be plugged into the guide rails with coding and into the keying/coding block; provides conductive contact between the alignment pin of the insertion/extractor handle (IEL or IET handle) and the horizontal rail	PBT, UL 94 V-0, keying/coding block is clipped into the horizontal rail next to the guide rail; please order keying/coding pegs separately	Keying/coding peg, PBTP, UL 94 V-0, RAL 7035 The keying/coding pegs prevent plug-in units to be mounted in wrong slots. They are inserted in the chambers of the codable card guides as well as in the insertion/extractor handles IEL or IET (4 possible positions), resulting in 64 codings per card guide; when coding the upper and lower card guide, 4096 codings will result;
Assembly	Colour	PU 50 pieces	1 piece (SPQ 50)	PU 100 pieces
above	red	—	34579-232	—
	grey	—	34579-233	20817-501
	silver	24560-256	—	—
below	red	—	34579-234	—
	grey	—	34579-235	20817-501
	silver	24560-256	—	—

1) SPQ (standard pack quantity): Part number includes 1 piece, but delivery is exclusively made in standard pack quantity (SPQ); please order at least the SPQ quantity or a multiple

2) Part no. includes one packing unit (PU); delivery is exclusively made in PU

Guide rail accessories

Order Information

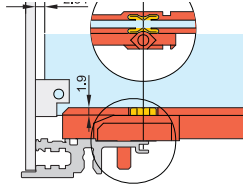
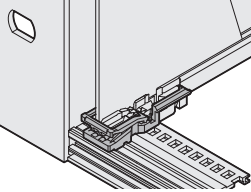
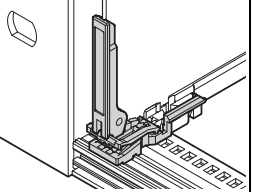
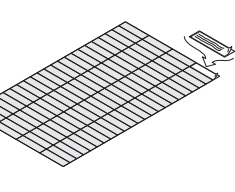
		ESD clips for guide rails	Board locking for PCBs without front panel; for accessory type guide rails	PCB handle for board locking; for accessory type guide rails	Identification strips
		 04503050	 04805050	 04805051	 06108076
		Spring steel, tin-plated, provides conductive contact between board and horizontal rail, on both the solder side and the component side	PBT, UL 94 V-0, red, to fix the PCB in the subrack (also slot 1), can also be used without board handle, minimum distance 3 HP	PBT, UL 94 V-0, red, insertion/ extraction function with connection to board locking (also slot 1), mounting directly behind front panel (above and below), minimum distance 3 HP	Polyester film, 31 x 4 mm, self-adhesive, white/matt (1 A4 sheet contains 438 pieces)
Assembly	Colour	silver PU 50 pieces	red PU 10 pieces	red PU 10 pieces	white/matt 1 piece
above/below		24560-255	24560-377	24560-378	60817-228

Shielding for top and bottom

Cover plates can be used for electromagnetic shielding (with EMC contact springs) or as mechanical protection (without EMC springs)

Cover plates for mechanical protection

- Cover plates are inserted into the grooves of the front and rear horizontal rails, type L "light"

see page 6.43

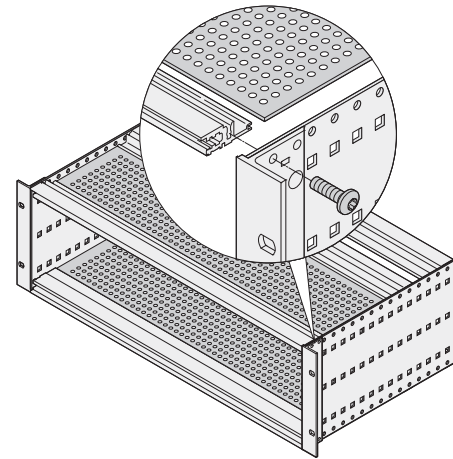

06108077

Cover plates with EMC shielding and mechanical protection

EMC cover plates for top and bottom

- Inserted in the groove of the front and rear horizontal rails; shielding with contact springs, lateral contact by bolting the bracket to the side panel
- Used when standard-depth PCBs (160, 220, 280, ...) are fitted

see page 6.44

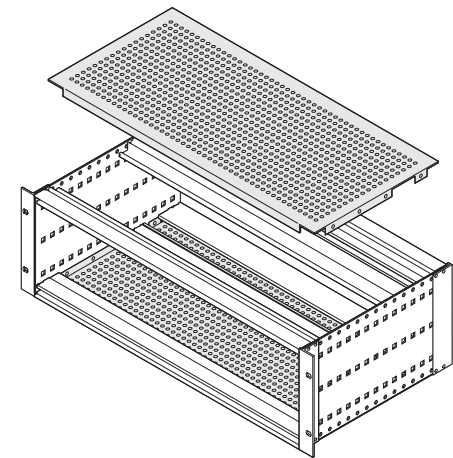

06102084

Universal EMC cover plates for top and bottom

- Inserted in the groove of the front and rear horizontal rails; shielding with contact springs, lateral contact by bolting to the side panel with special contact springs
- Used when PCBs with special dimensions are fitted

see page 6.45

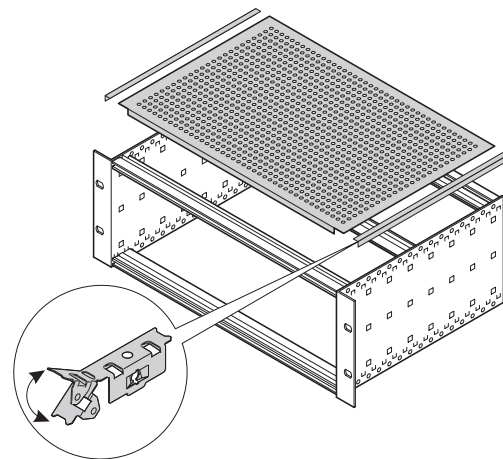

06105082

Subracks - *europac PRO* ServicePLUS

Cover plates for mechanical protection
(insertion into horizontal rail type L)

Order Information

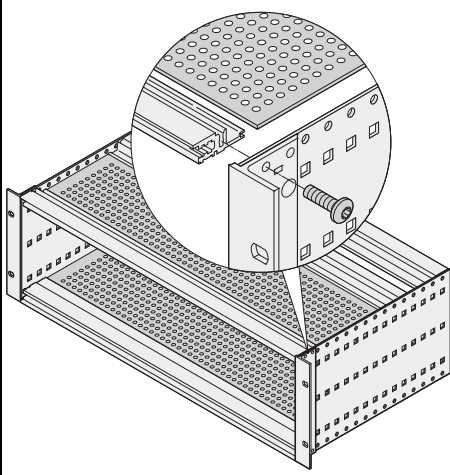

06197010

**Cover plates
for insertion into
horizontal rail type L**

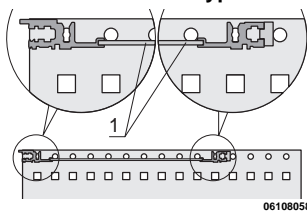

06108058

Perforated Al plate, 1.2 mm,
hole diameter 3.8 mm,
Al, untreated,
perforation degree 60 %;
for insertion into the groove of the
light horizontal rails (type L)

Width HP	Depth mm	Application	PU 1 pair
42	175	160 mm board depth	24561-031
63	175	160 mm board depth	24561-041
84	175	160 mm board depth	24561-051
84	235	220 mm board depth	24561-052

Note

- Other dimensions on request

EMC cover plates and mechanical protection

- Cover plate for bolting to side panel
- Used when standard-depth PCBs (160, 220, 280, ...) are fitted

Order Information

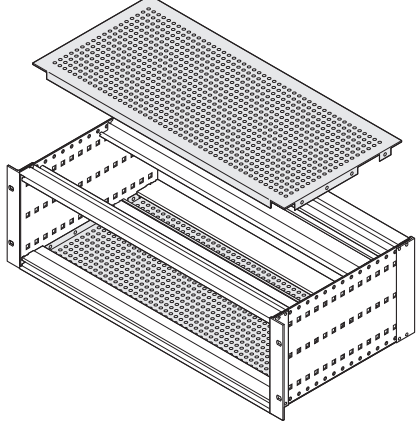
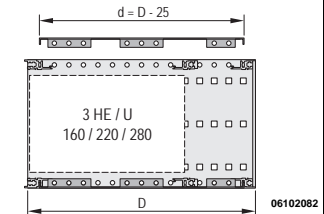
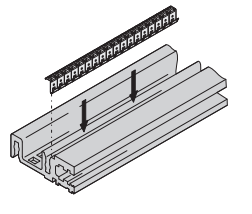
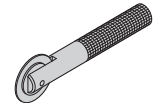
						
			Cover plate for bolting to side panel d = D - 25 3 HE / U 160 / 220 / 280 06102062		Stainless steel EMC gasket, between cover plate and horizontal rail 06106052	
			Al, 1.0 mm, hole diameter 4.0 mm, passivated, perforation degree 58 %, incl. fixing screws; for shielding 4 stainless steel EMC gaskets are required per subrack		stainless steel EMC gasket, clips into the horizontal rail and forms the contact with the cover plate; suitable for all horizontal rails	
Width	Depth	Application				
HP	mm		PU 1 pair	PU 10 pieces	PU 100 pieces	
42	175	160 mm board depth	24560-064			
42	235	160, 220 mm board depth	24560-065			
42	275	160, 220 mm board depth CompactPCI (275 mm)	24560-061	24560-241	-	
42	277.75	160, 220 mm board depth VME64x (277.75 mm)	24579-090			
42	295	160, 220, 280 mm board depth	24560-066			
63	175	160 mm board depth	24560-071			
63	235	160, 220 mm board depth	24560-072	24560-243	-	
63	275	160, 220 mm board depth CompactPCI (275 mm)	24560-062			
63	295	160, 220, 280 mm board depth	24560-073			
84	175	160 mm board depth	24560-078			
84	235	160, 220 mm board depth	24560-079			
84	275	160, 220 mm board depth CompactPCI (275 mm)	24560-063	24560-245	24560-246	
84	277.75	160, 220 mm board depth VME64x (277.75 mm)	24579-092			
84	295	160, 220, 280 mm board depth	24560-080			
84	355	160, 220, 280 mm board depth	24560-081			
84	415	160, 220, 280 mm board depth	24560-082			
84	475	160, 220, 280 mm board depth	24560-083			
Assembly tool, for EMC gasket, stainless steel (horizontal rails), 1 piece 			-	24560-271		

Note

- Cover plates without perforation available on request

■ Used when PCBs with special dimensions are fitted

Order Information

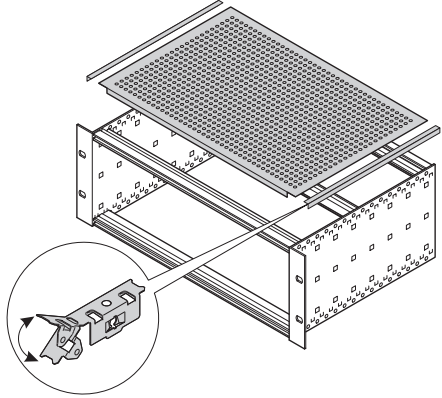
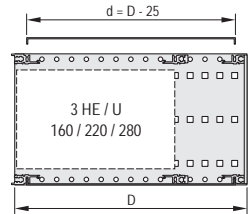
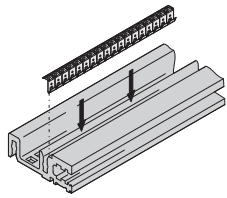
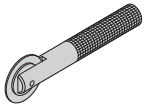
 <p>06105082</p>			<p>Universal cover plate</p>  <p>06108079</p> <p>Al, 1.0 mm, hole diameter 4.0 mm, passivated, perforation degree 58 %, incl. lateral EMC sealing, incl. fixing screws</p>		<p>Stainless steel EMC gasket, between cover plate and horizontal rail</p>  <p>06106052</p> <p>stainless steel EMC gasket, clips into the horizontal rail and forms the contact with the cover plate; suitable for all horizontal rails</p>	
Width HP	Depth mm	Application	PU 1 pair	PU 10 pieces	PU 100 pieces	
42	175	160 mm board depth	24560-031			
42	235	160, 220 mm board depth	24560-032	24560-241	–	
42	295	160, 220, 280 mm board depth	24560-033			
63	175	160 mm board depth	24560-041			
63	235	160, 220 mm board depth	24560-042	24560-243	–	
63	295	160, 220, 280 mm board depth	24560-043			
84	175	160 mm board depth	24560-051			
84	235	160, 220 mm board depth	24560-052			
84	295	160, 220, 280 mm board depth	24560-053	24560-245	24560-246	
84	355	160, 220, 280 mm board depth	24560-054			
84	415	160, 220, 280 mm board depth	24560-055			
84	475	160, 220, 280 mm board depth	24560-056			
<p>Assembly tool, for EMC gasket, stainless steel (horizontal rails), 1 piece</p> 			–	24560-271		

Cover/shielding to front and rear

- The front and rear sides of the subrack can be shielded by a hinged front panel or by a fixed front panel and 19" brackets
- The rear can be shielded with a front panel and a corner profile

Rear hood

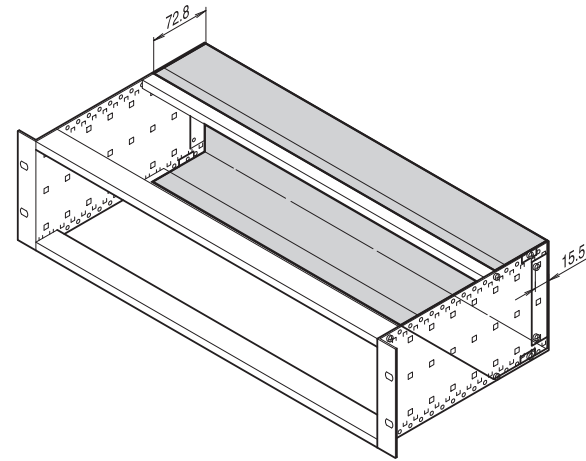

BZA45814

Front panel for front and rear

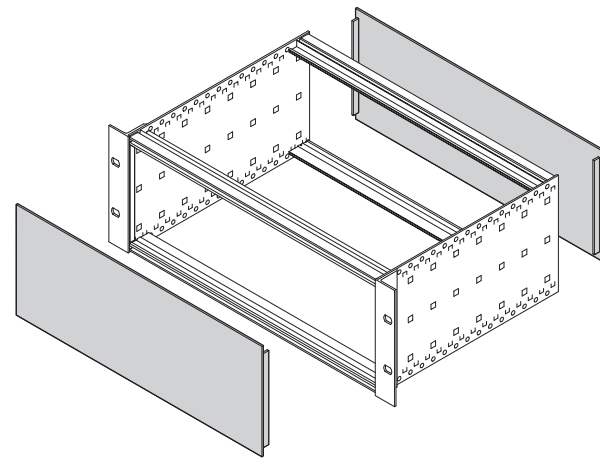

06112089

Front panel, hinged/pivoted

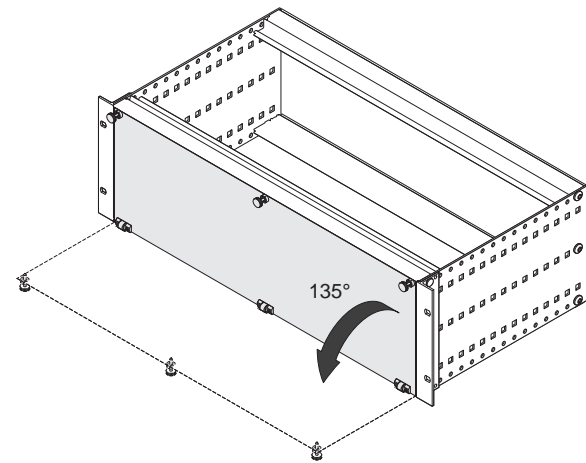

06112090

Subracks - *europac PRO* ServicePLUS

Rear hood for 3 U and 6 U subracks
(for stainless steel EMC gasket)

Order Information

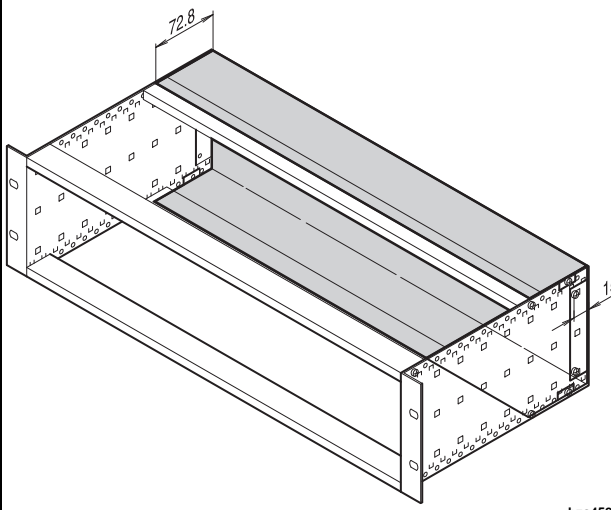
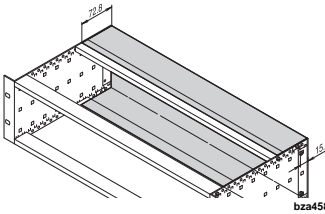
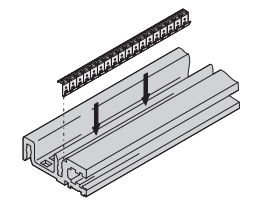
		<p>Rear hood</p>  <p>Al, 1 mm, clear passivated; 60 mm additional side panel depth required (board depth + 60 mm); for shielding please order EMC gasket for horizontal rail separately; cannot be used simultaneously with rear corner profile</p>	<p>Stainless steel EMC gasket, between cover plate and horizontal rail</p>  <p>stainless steel EMC gasket, clips into the horizontal rail and forms the contact with the cover plate; suitable for all horizontal rails</p>	
Height	Width	1 piece	PU 10 pieces	PU 100 pieces
U	HP			
3	42	34561-750	24560-241	—
3	84	34561-752	24560-245	24560-246
6	63	34561-763	24560-243	—
6	84	34561-764	24560-245	24560-246
Torx panhead screw, M4 x 6, St, zinc-plated, PU 100 pieces		24560-135	—	
Assembly tool, for EMC gasket, stainless steel (horizontal rails), 1 piece		—	24560-271	

Note

- Other dimensions of rear hood available on request

Front/rear panels, unshielded

FRONT PANEL
EXPRESS

Order Information

 04292001			Front panel					
			pre-anodised, cut edges plain Al, 2.5 mm		anodised Al, 2.5 mm		Front anodised, rear iridescent green chromated Al, 2.5 mm	
Height U	Height mm	Width HP	1 piece	1 piece (SPQ 5) ¹⁾	1 piece	1 piece (SPQ 5) ¹⁾	1 piece	1 piece (SPQ 5) ¹⁾
1	44.45	28	-	-	-	-	20850-423	-
1	44.45	42	-	-	-	-	20850-424	-
1	44.45	63	-	-	-	-	20850-425	-
1	44.45	84	-	-	-	-	20850-426	-
2	84.0	84	30818-271	-	30807-416	-	30847-461	-
3	128.4	2	-	30810-433	-	30810-432	-	30847-470
3	128.4	3	-	30818-272	-	30807-508	-	30847-471
3	128.4	4	-	30818-273	-	30807-481	-	30838-043
3	128.4	5	-	30818-274	-	30807-510	-	30838-044
3	128.4	6	-	30818-275	-	30807-482	-	30838-045
3	128.4	7	-	30818-276	-	30807-509	-	30838-046
3	128.4	8	-	30818-277	-	30807-484	-	30838-047
3	128.4	10	-	30818-279	-	30807-483	-	30838-049
3	128.4	12	-	30818-281	-	30807-485	-	30838-051
3	128.4	14	-	30818-282	-	30807-501	-	30838-053
3	128.4	21	-	30818-289	-	30807-487	-	30838-060
3	128.4	28	-	30818-296	-	30807-496	-	30838-067
3	128.4	42	30818-310	-	30807-494	-	30838-081	-
3	128.4	63	30818-331	-	30808-067	-	30838-102	-
3	128.4	84	30818-352	-	30807-506	-	30838-123	-
4	172.9	42	-	-	-	-	30847-463	-
4	172.9	63	-	-	-	-	30847-464	-
4	172.9	84	30818-434	-	30807-596	-	30847-465	-
6	261.8	2	-	30818-747	-	30818-741	-	30847-472
6	261.8	4	-	30818-518	-	-	-	30838-124
6	261.8	5	-	-	-	-	-	30838-125
6	261.8	6	-	-	-	-	-	30838-126
6	261.8	7	-	-	-	-	-	30838-127
6	261.8	8	-	30818-522	-	-	-	30838-128
6	261.8	10	-	30818-524	-	30807-753	-	30838-130
6	261.8	12	-	30818-526	-	-	-	30838-132
6	261.8	14	-	30818-528	-	30807-758	-	30838-134
6	261.8	16	-	30818-530	-	-	-	30838-136
6	261.8	21	-	30818-535	-	30807-757	-	30838-141
6	261.8	28	-	30818-542	-	30807-766	-	30838-148
6	261.8	42	30818-556	-	30807-764	-	30838-162	-
6	261.8	63	30818-577	-	30807-771	-	30838-183	-
6	261.8	84	30818-598	-	30807-776	-	30838-204	-
9	395.1	4	-	-	-	-	-	30847-476
9	395.1	8	-	-	-	-	-	30847-480
9	395.1	10	-	-	-	-	-	30847-482
9	395.1	12	-	-	-	-	-	30847-484
9	395.1	84	-	-	-	-	30847-556	-

■ Front panel assembly kits, sleeves, collar screws, quick-release fasteners see page 6.63

1) SPQ (standard pack quantity): Part number includes 1 piece, but delivery is exclusively made in standard pack quantity (SPQ); please order at least the SPQ quantity or a multiple

Subracks - *europac* **PRO** ServicePLUS

Front/rear panels shieldable with stainless steel EMC gasket

FRONT PANEL *EXPRESS*

Order Information

Height			Front panel			
U	mm	HP	Front panel for shielding with EMC gasket (stainless steel) <small>Al, 2.5 mm, front anodized, rear iridescent green chromated, 2 alignment pins pressed-in, St, stainless</small>		Stainless steel EMC gasket <small>inserted laterally into the grooves of the front panel, suited for temperatures above 70 °C</small>	
			1 piece	1 piece (SPQ 5) ¹⁾	PU 10 pieces	PU 100 pieces
2	84	84	30846-588	-	21101-775	21101-776
3	128.4	2	-	30846-864	21101-705	21101-706
3	128.4	3	-	20846-425		
3	128.4	4	-	20846-426		
3	128.4	5	-	20846-427		
3	128.4	6	-	20846-428		
3	128.4	7	-	20846-429		
3	128.4	8	-	20846-430		
3	128.4	10	-	20846-431		
3	128.4	12	-	20846-432		
3	128.4	14	-	20846-433		
3	128.4	21	-	20846-434		
3	128.4	28	-	20846-436		
3	128.4	42	20846-437	-		
3	128.4	63	20846-438	-		
3	128.4	84	30846-676	-		
4	172.9	42	30846-681	-	21101-713	21101-714
4	172.9	63	30846-682	-		
4	172.9	84	30846-683	-		
6	261.8	2	-	30846-865	21101-707	21101-708
6	261.8	4	-	20846-443		
6	261.8	5	-	20846-444		
6	261.8	6	-	20846-445		
6	261.8	7	-	20846-446		
6	261.8	8	-	20846-447		
6	261.8	10	-	20846-448		
6	261.8	12	-	20846-449		
6	261.8	14	-	20846-450		
6	261.8	16	-	20846-456		
6	261.8	21	-	20846-451		
6	261.8	28	-	20846-452		
6	261.8	42	20846-453	-		
6	261.8	63	20846-454	-		
6	261.8	84	30846-771	-		
9	395.1	84	30846-859	-	21101-709	21101-710
Assembly tool, for stainless steel EMC gasket					24560-270	

■ Front panel assembly kits, sleeves, collar screws, quick-release fasteners see page 6.63

1) SPQ (standard pack quantity): Part number includes 1 piece, but delivery is exclusively made in standard pack quantity (SPQ); please order at least the SPQ quantity or a multiple

Subracks - *europac PRO* ServicePLUS

Front/rear panels shieldable with textile EMC gasket

FRONT PANEL EXPRESS



Order Information

 04292001			Front panel			
			Front panel for shielding with EMC sealing (textile)		Textile EMC gasket	
Height U	Height mm	Width HP	1 piece	1 piece (SPQ 5) ¹⁾	PU 10 pieces	PU 100 pieces
2	84	84	20848-262	-	-	21101-856
3	128.4	2	-	30849-001	21101-853	21101-854
3	128.4	3	-	30849-004		
3	128.4	4	-	30848-354		
3	128.4	5	-	30848-378		
3	128.4	6	-	30848-380		
3	128.4	7	-	30848-382		
3	128.4	8	-	30848-356		
3	128.4	10	-	30848-386		
3	128.4	12	-	30848-358		
3	128.4	14	-	20848-013		
3	128.4	21	-	20848-020		
3	128.4	28	-	20848-027		
3	128.4	42	20848-047	-		
3	128.4	63	20848-068	-		
3	128.4	84	20848-097	-		
4	172.9	28	-	20848-268	21101-858	-
4	172.9	42	20848-269	-		
4	172.9	63	20848-270	-		
4	172.9	84	20848-271	-		
6	261.8	2	-	30849-002	21101-855	21101-856
6	261.8	4	-	30848-355		
6	261.8	5	-	30848-379		
6	261.8	6	-	30848-381		
6	261.8	7	-	30848-383		
6	261.8	8	-	30848-357		
6	261.8	10	-	30848-387		
6	261.8	12	-	30848-359		
6	261.8	14	-	20848-106		
6	261.8	16	-	20848-108		
6	261.8	21	-	20848-113		
6	261.8	28	-	20848-120		
6	261.8	42	20848-139	-		
6	261.8	63	20848-160	-		
6	261.8	84	20848-189	-		
9	395.1	84	20848-280	-	21101-859	21101-904

■ Front panel assembly kits, sleeves, collar screws, quick-release fasteners see page 6.63

1) SPQ (standard pack quantity): Part number includes 1 piece, but delivery is exclusively made in standard pack quantity (SPQ); please order at least the SPQ quantity or a multiple

Order Information

Height U	Width HP	Front panel, bottom-hinged		Front panel, pivoted
		shielded	unshielded	
				
		Al, 2.5 mm, front anodised, rear iridescent green chromated; hinge, Zn die-cast, nickel-plated; 2 x sleeve, PA; 2 x knurled screws M2.5 x 12.3, St, nickel-plated; 1 x textile EMC gasket	Al, 2.5 mm, anodised, cut edges plain; hinge, Zn die-cast, nickel-plated; 2 x sleeve, PA; 2 knurled screws M2.5 x 12.3, St, nickel-plated	Al, 2.5 mm, front anodised, rear iridescent green chromated; hinge, die-cast zinc, chrome-plated; textile EMC gasket
		1 piece	1 piece	1 piece
3	28	20848-608	20838-280	-
3	42	20848-599	20838-271	-
3	63	20848-600	20838-272	-
3	84	20848-601	20838-273	20848-611
4	42	20848-605	20838-277	-
4	63	20848-606	20838-278	-
4	84	20848-607	20838-279	-
6	28	20848-696	-	-
6	42	20848-602	20838-274	-
6	63	20848-603	20838-275	-
6	84	20848-604	20838-276	20848-617

Note

- Front panel can be removed in opened position (> 135°)

Shielding is required between the following components of a subrack

- Front panel/rear panel and horizontal rail, see page 6.53
- Front panel and 19" bracket/corner profile or in case of depth-offset installation, see page 6.53
- Cover plate/horizontal rail, see page 6.42
- Cover plate/side panel, see from page 6.42
- Horizontal rail/horizontal rail in combined mounting (3 U + 3 U and 6 U), see page 6.57
- Shielding for backplane and side panel see page 6.53

EMC shielding concepts

- Shielding concepts in accordance with IEEE and IEC
- Shielding effectiveness has been determined in various series of measurements in accordance with IEC 61587-3 and can be found online together with the relevant standard product
- The combined use of stainless steel and textile EMC gaskets is functionally possible without any problems

EMC shielding concept with EMC textile gaskets

- The seal is affixed to the left-hand side of the subrack (viewed from front) or to the front panel profile, respectively
- An EMC gasket with CuNi coating assures a long-term high level of shielding, typically 40 dB at 2 GHz
- Temperature-resistant adhesive layer is protected by a removable film
- Rear shielding is obtained using front panels or a rear hood
- Temperature range -40° C ... +70° C
- **Note:** rear hood and corner profile cannot be used simultaneously

EMC shielding concept with stainless steel EMC gaskets)

- Symmetrical arrangement of EMC gaskets on the left and right hand sides of subrack and front panel
- Shielding: typically 40 dB at 2 GHz
- Can be used for temperatures above +70° C
- **Note:** rear hood and corner profile cannot be used simultaneously

Front panel shielding concept

- Front panels are available for textile or stainless steel EMC gasket options
- Alignment pins are pressed-in in the front panel to position the gaskets securely and to compress them evenly
- An alignment pin positions the perforated strip in the horizontal rail
- Alignment pin and perforated strip provide an optimal positioning of the shielded assemblies; the front panels are not forced sideways by the shielding elements (Schroff patent)

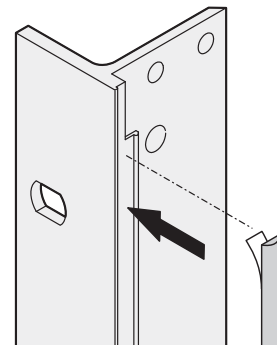

06108073

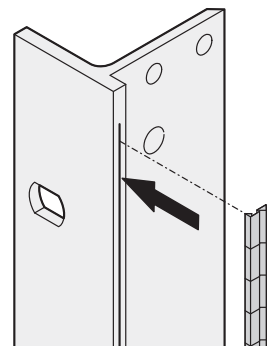

06108074

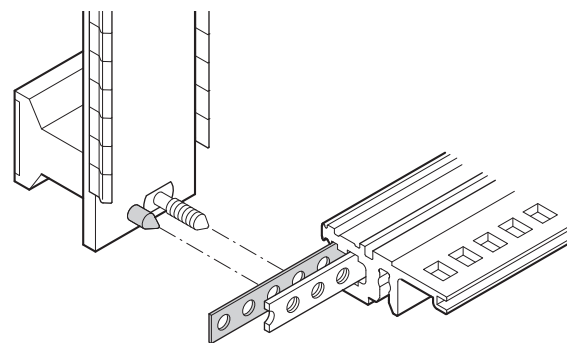

06112091

Part number in bold face type: ready for despatch within 2 working days
Part number in normal type: ready for despatch within 10 working days

Subracks - *europac PRO* ServicePLUS

EMC gaskets between front/rear panel and horizontal rail

Order Information

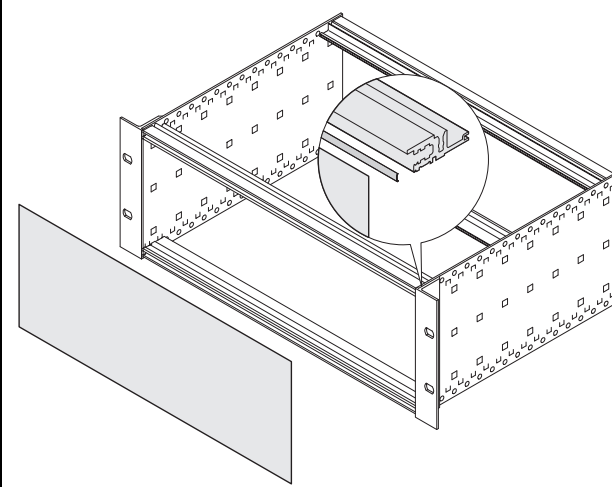
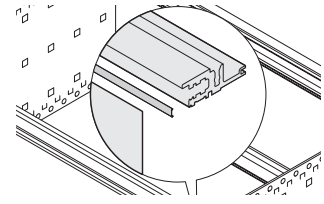
 <p>06102053</p>	Stainless steel EMC gasket between front panel/rear panel and horizontal rail		 <p>06102053</p>	
	stainless steel; for front and rear horizontal rails (type VT)			
Width HP	Depth mm	PU 10 pieces	PU 100 pieces	
28	131.8	24560-229	-	
42	202.9	24560-231	-	
63	304.5	24560-233	-	
84	416.6	24560-235	24560-236	

EMC gaskets between front panel and 19" bracket/corner profile

Order Information

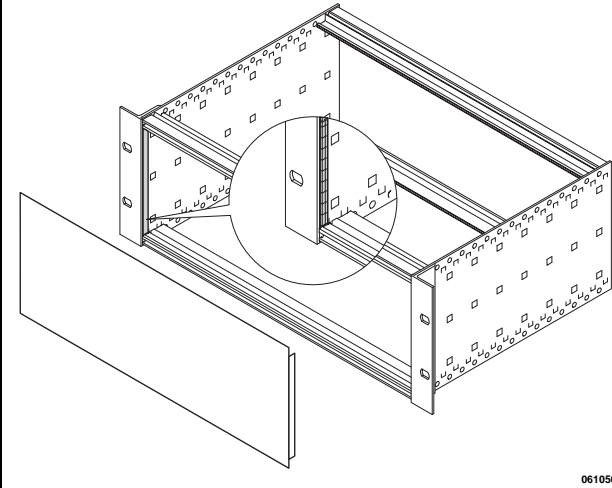
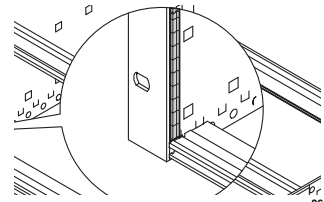
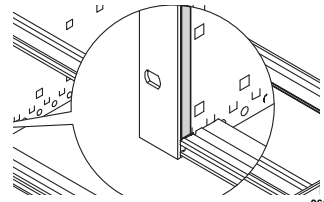
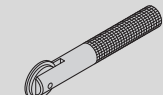
 <p>06105077</p>	Stainless steel EMC gasket between front panel/rear panel and 19" bracket/corner profile		Textile EMC gasket between front panel/rear panel and 19" bracket/corner profile		
	 <p>06105077</p>		 <p>06102056</p>		
inserted laterally into the grooves of the front panel		textile gasket, core: foam, sleeve: textile cladding with CuNi coating, UL 94 V-0			
Height U	Depth mm	PU 10 pieces	PU 100 pieces	PU 10 pieces	PU 100 pieces
3	97.5	21101-705	21101-706	21101-853	21101-854
4	142.5	21101-713	21101-714	21101-858	-
6	232.5	21101-707	21101-708	21101-855	21101-856
9	365.0	21101-709	21101-710	21101-859	21101-904
Assembly tool, for stainless steel EMC gasket 		24560-270		-	

EMC gaskets between horizontal rail and horizontal rail

Order Information

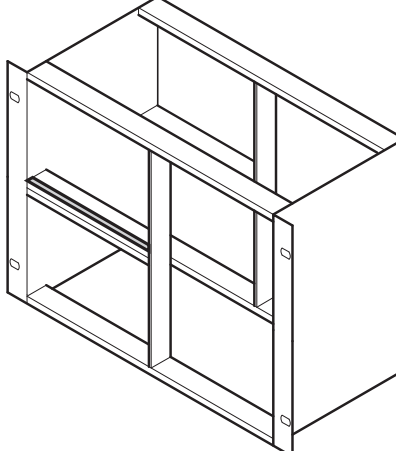

bpa46548

**Stainless steel EMC gasket
between horizontal rail and horizontal rail**

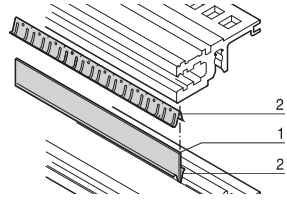

bz245877

Item 1: cover strip, Al, 1 mm,
item 2: 2 x EMC seals (stainless steel);
for shielding of 2 horizontal rails positioned directly one above the other
if assembly area is divided vertically

	Width HP	Depth mm	
			PU 1 kit
	20	107.0	24562-520
	28	147.0	24562-528
	40	208.0	24562-540
	42	218.0	24562-542
	63	325.0	24562-563
	84	431.0	24562-584

1) SPQ (standard pack quantity): Part number includes 1 piece, but delivery is exclusively made in standard pack quantity (SPQ); please order at least the SPQ quantity or a multiple

EMC gaskets between front panel and side panel
(depth-offset installation)

Order Information

	Height U	Depth mm		
			PU 1 kit	PU 1 kit
	3	97.5	24562-199	24560-180
	4	142.5	24562-299	24560-280
	6	187.5	24562-499	24560-480
Assembly tool, for stainless steel EMC gasket			24560-270	-

**Stainless steel EMC gasket
between front panel and side panel
(depth-offset installation)**

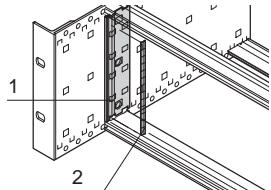

bpa45884

Item 1: 2 x support profiles, Al extrusion;
item 2: 2 x stainless steel EMC gasket;
fixing material kit for vertical EMC shielding between
depth-offset shielded front panels and side panel

**Textile EMC gasket
between front panel and side panel
(depth-offset installation)**

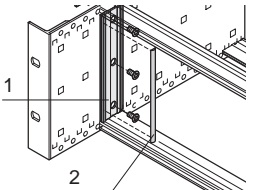

06102058

Item 1: 2 x support profiles, Al extrusion;
item 2: 1 x EMC textile gasket;
fixing material kit for vertical EMC shielding between
depth-offset shielded front panels and side panel

Subracks - *europacPRO* ServicePLUS

EMC gaskets between backplane and side panel

Order Information

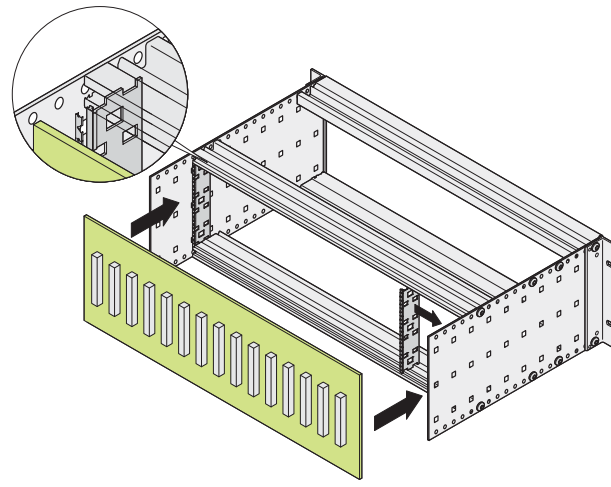
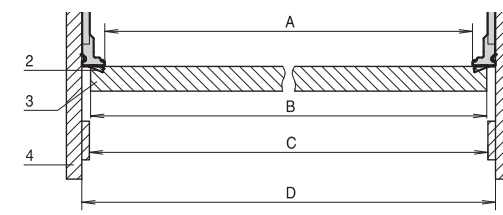
 <p>06108078</p>	<p>Stainless steel EMC gasket between backplane and side panel (depth-offset installation)</p>  <p>bp44916</p> <p>2 x support profile, Al extrusion, 2 x EMC gasket (stainless steel) Fixing materials kit and user manual; for vertical EMC shielding between shielded backplane and side panel;</p> <p>dimensions (84 HP): A = 425.8 mm, B < 429.9 mm, C = 429.8 mm, D = 431.8 mm</p> <p>PU 1 kit</p>
<p>Height</p>	
<p>U</p>	
<p>3</p>	<p>24561-199</p>
<p>6</p>	<p>24561-499</p>

- With an appropriate design the backplane can be used as shielding rear panel; for that purpose a rear horizontal rail (type L-VT or H-VT) for depth-offset installation must be used to ensure the horizontal contact
- For vertical contact the support profile can be fixed to the europacPRO side panel (depth grid 30 mm)

Special interior mounting parts

- Combined mounting: 3 U + 3 U and 6 U, see page 6.57
- Horizontal board mounting, see page 6.58
- Mounting plates, see page 6.59
- Central locking for PCBs, see page 6.60
- Divider plates, see page 6.60
- Air baffles, see page 6.61
- Telescopic slides, see page 6.62
- Fixing parts (bolts, nuts, assembly tools), see page 6.63

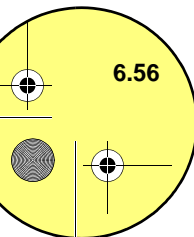

6.56

Main Catalogue
E 10/2012

Part number in bold face type: ready for despatch within 2 working days
Part number in normal type: ready for despatch within 10 working days

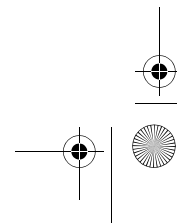
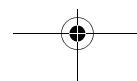

Order Information

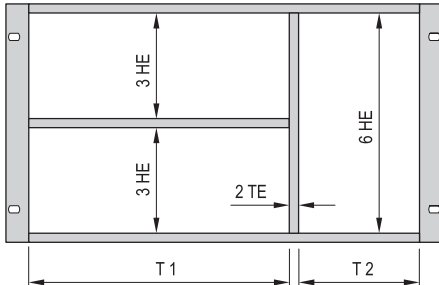
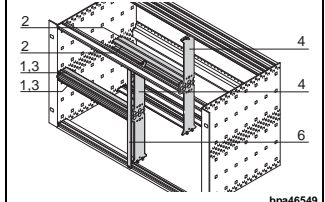
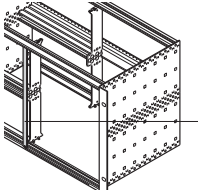
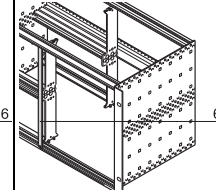
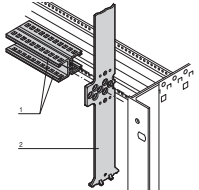
	Combined mounting: horizontal and vertical subdivision (incl. front panel for stainless steel EMC gasket)	Alternative front panels for combined mounting		Splitting extrusion for combined mounting item 2
		unshielded front panel, 6 U, 2 HP item 6 	front panel for textile EMC gasket, 6 U, 2 HP item 6 	
Item 1: 2 front horizontal rails (H-KD), Al extrusion, anodised; item 2: 2 rear horizontal rails (AB), Al extrusion, anodised; item 3: threaded inserts, St, zinc-plated; item 4: Zn die-cast support members; item 6: front panel 2 HP, 6 U, with EMC stainless steel gasket; 84:0 without items 4, 5 Note see below 2)	Al, 2.5 mm, front anodised, rear iridescent green chromated	Al, 2.5 mm, U-profile with notch, 6 U, 2 HP	6 U, die-cast zinc; splitting extrusion is inserted in the grid holes of the horizontal rail; the splitting extrusion can be bolted	
Width pitch T1:T2 HP	PU 1 kit	1 (SPQ 5)	1 piece (SPQ 5)¹⁾	1 piece
20:62	24562-420			
40:42	24562-440			
42:40	24562-442	30847-472	30849-140	64560-010
63:19	24562-463			
84:0	24562-484			
Torx countersunk screw M4 x 14, zinc-plated, PU 100 pieces to fix splitting extrusion/horizontal rail	-	-	-	24560-145
Panhead screw M2.5 x 10, St, zinc-plated, PU 100 pieces to fix horizontal rail/splitting extrusion	-	-	-	24560-179
Pozidrive/slotted collar screw M2.5 x 12.3, St, nickel-plated, PU 100 pieces	-	21101-101	21101-101	-
Pozidrive/slotted collar screw M2.5, black, zinc-plated, PU 100 pieces	-	21101-102	21101-102	-
Washer 2.7 x 5 x 1, PA 6, PU 100 pieces	-	21101-121	21101-121	-
Textile gasket, core: foam, sleeve: textile cladding with CuNi coating, UL 94 V-0 PU 10 pieces	-	-	21101-855	-

2) The following guide rails cannot be used: type "accessory", type "accessory, strengthened" and type "for 4.4" PCB"

- Subdivision of the 6 U assembly area into:
 - 2 x 3 U
 - 1 x 6 U
- Designed to accommodate euroboards (100 mm high) and double euroboards (233.35 mm high)

Note

- Please order EMC gasketing kit for horizontal rails separately, see page 6.54
- Please order perforated strips for horizontal rails separately, see page 6.33
- Please order rear centre horizontal rail separately, see page 6.31

Horizontal board mounting in 3 or 4 U subrack

Order Information

				Horizontal board mounting in 3 or 4 U subrack		
				Board cage	Front frame for EMC shielding	Front frame, unshielded
<p>(1 TE = 1 HP, 1 HE = 1 U)</p> <p>Height U Usable height h HP</p> <p>Mounting variants: Horizontal rail, front; Horizontal rail, rear</p>				<p>Struts, die-cast zinc; horizontal rails front and rear; threaded inserts, St, zinc-plated; fixing material kit; for horizontal mounting of double-height euroboards in 3 or 4 U high subracks/cases; 54 HP space required; please order front frame for EMC shielding separately</p> <p>06102073</p>	<p>2 horizontal covers, Al 2.5 mm, front anodised, rear iridescent green chromated; 2 vertical trims, Al extrusion, passivated; stainless steel EMC gasket; front frame provides the contact between subrack and the sub-assemblies</p> <p>bpa45913</p>	<p>Al, 2.5 mm, clear anodised; front frame with cut-out, clear internal width w = 266.35 mm</p> <p>bza43061</p>
				PU 1 kit	PU 1 kit	1 piece
3	20			24564-117	24564-109	34564-108
3	20			24564-118	24564-109	34564-109
4	28			24564-217	24564-209	34564-208
<p>Assembly tool, for stainless steel EMC gasket</p>				-	24560-270	-

* For direct backplane mounting

Note

- Please order front frame for EMC shielding separately

Mounting plates

Order Information

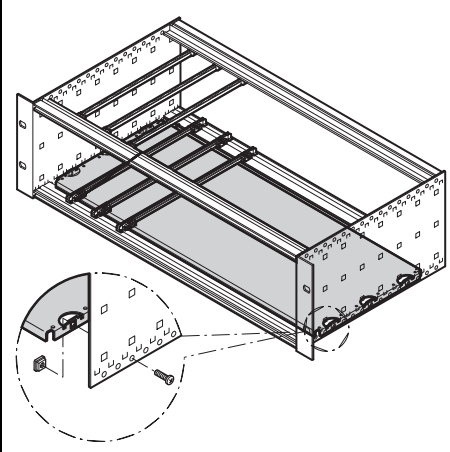
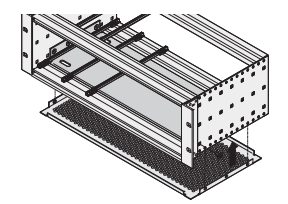
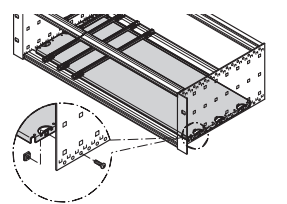
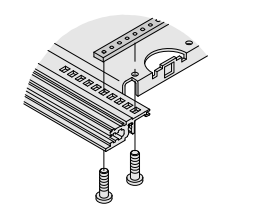
			 <p>Mounting plate can be used in combination with cover plate</p> <p>Al, 1.5 mm; mounting is only possible over the entire width between the side panels; width of mounting plate = W - 9.71 mm</p>	 <p>Mounting plate for use without cover plate</p> <p>Al, 1.5 mm; for mounting over partial width, please order fixing strips separately</p>	 <p>Fixing strip for partial widths</p> <p>St, 2 mm, zinc-plated; is bolted from front to rear onto the horizontal rails; to fix mounting plates</p>
Width W HP	W mm	Board length mm	1 piece	1 piece	1 piece
28	146.88	160	34563-001	34562-745	30840-021
28	146.88	220	34563-009	34562-749	30840-033
28	146.88	280	—	34562-753	30840-045
28	146.88	340	—	34562-757	30840-057
42	217.99	160	34563-002	34562-746	30840-021
42	217.99	220	34563-014	34562-750	30840-033
42	217.99	280	—	34562-754	30840-045
42	217.99	340	—	34562-758	30840-057
63	324.67	160	34563-003	34562-747	30840-021
63	324.67	220	34563-019	34562-751	30840-033
63	324.67	280	—	34562-755	30840-045
63	324.67	340	—	34562-759	30840-057
84	431.35	160	34563-004	34562-748	30840-021
84	431.35	220	34563-024	34562-752	30840-033
84	431.35	280	—	34562-756	30840-045
84	431.35	340	—	34562-760	30840-057
Assembly kit for mounting plate, PU 1 kit (Torx countersunk screw M4 x 5, St, zinc-plated, 12 pieces; screw M4 x 6, St, zinc-plated, 10 pieces; square nut M4, St, zinc-plated, 10 pieces)			24560-184	24560-184	—
Assembly kit for fixing strips for partial width mounting plates Torx screw M2.5 x 5, St, zinc-plated, PU 100 pieces			—	—	24560-146

Note

- For installation and fixing of heavy components
- In addition to the mounting plate, (EMC) cover plates can also be fitted to the subrack
- The mounting plate is as wide as the subrack or system case and is fixed to the side panels
- A guide rail can be fitted on the first and last slot
- Guide rails type "4.4" and type "strengthened" cannot be used

Central locking

Order Information

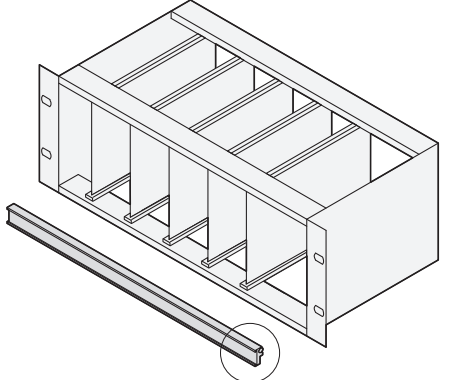

**Central locking
for PCBs without front panels**

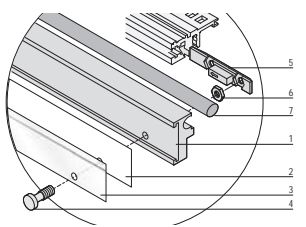

Item 1: central rail, Al, anodised;
 item 2: ID cardboard, white;
 item 3: transparent cover strip, plastic;
 item 4: 2 x knurled screw;
 item 5: 2 x slide nut;
 item 6: 2 x hexagon nut M2.5;
 item 7: rubber gasket;

central locking allows joint locking of PCBs and serves as identification strip;
 can be fitted to front and rear horizontal rails,
 suitable for 84 HP width

06197010

Width HP	Length mm	1 piece
84	426.0	24560-167

Divider plate

Order Information

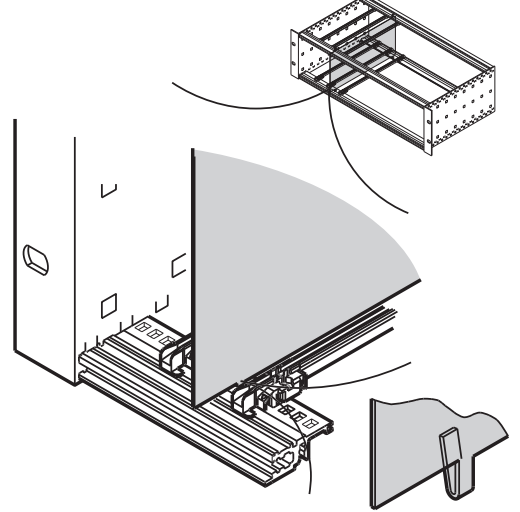

Divider plate

**Mounting position when
stainless steel EMC gasket is used**

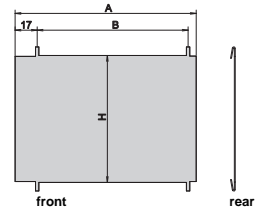

**Mounting position when
textile EMC gasket is used**

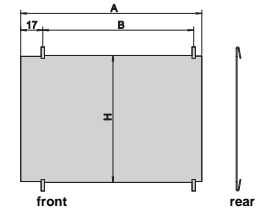

Stainless steel, 1 mm, is mounted by clipping onto horizontal rail,
 space requirement on component side 2 mm;
 mounting direction varies with shielding design (EMC stainless steel or textile gasket);
 retrofitting the divider plate in an already-assembled subrack/case
 will first require dismantling of the horizontal rails;
 where front panels are unshielded, both mounting directions are possible

06105078

Height U	Depth mm	A mm	B mm	H mm	
3	160	158.3	135.0	113.5	PU 10 pieces
3	220	218.3	195.0	113.5	34562-761
6	160	158.3	135.0	246.9	34562-762
6	220	218.3	195.0	246.9	34562-763
					34562-764

Air baffles for slots

Order Information

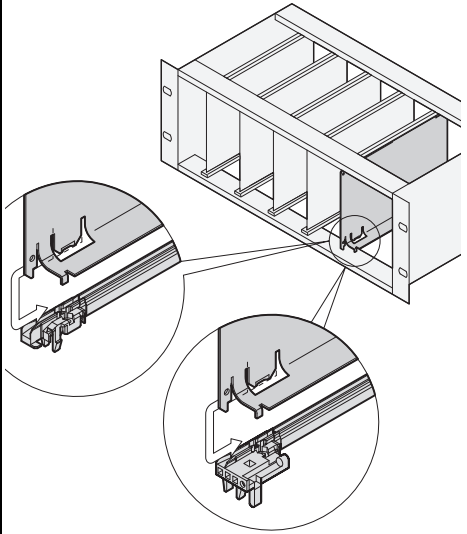
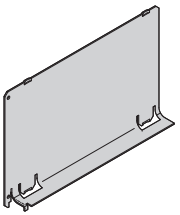
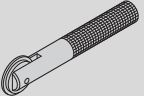
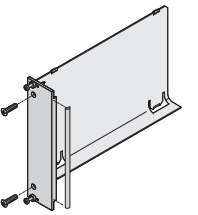
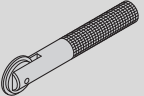
			Air baffle without front panel		Air baffle with front panel	
			Front panel with lateral groove for stainless steel EMC gasket		U front panel for textile EMC gasket	
			 <p>Al, 1 mm, incl. fixing material kit; prevents an air short circuit in unused slot positions; is pushed into the groove of the guide rail</p>	 <p>Air baffle, Al, 1 mm; front panel, Al, 2.5 mm, front anodised, rear conductive; stainless steel EMC gasket; fixing material kit prevents an air short circuit in unused slot positions; is pushed into the groove of the guide rail</p>	 <p>Air baffle, Al, 1 mm, front panel, Al extrusion, 2.5 mm, front anodised, rear conductive; textile EMC gasket; fixing material kit prevents an air short circuit in unused slot positions; is pushed into the groove of the guide rail</p>	
Depth mm	Width HP	Height U	1 piece	1 piece	1 piece	
160	4	3	34562-823	20848-712	20848-728	
160	4	6	34562-826	20848-720	20848-736	
160	8	3	34562-833	20848-714	20848-730	
160	8	6	34562-836	20848-722	20848-738	
160	12	3	34562-843	20848-716	20848-732	
160	12	6	34562-846	20848-724	20848-740	
220	4	3	34562-824	20848-713	20848-729	
220	4	6	34562-827	20848-721	20848-736	
220	8	3	34562-834	20848-715	20848-731	
220	8	6	34562-837	20848-723	20848-739	
220	12	3	34562-844	20848-717	20848-733	
220	12	6	34562-847	20848-725	20848-741	
Assembly tool for stainless steel EMC gasket, 1 piece 			-	24560-270	-	

Note

- Air baffle for 280 mm deep and for 80 mm rear I/O boards available on request

Simple telescopic slide for assembly of subracks in cabinets



- For mounting 84 HP wide subracks in the 19" plane
- Loading capacity: 25 kg per pair
- The guiding profile is matched to the fixing dimension in the cabinet (it is bolted to the 19" profile of the cabinet); the adaptor rail is matched to the depth and fixing dimension on the subrack (it is inserted into the guiding profile like a telescopic slide)
- Safety note:
No protection against extraction, no stop at full extension

06101006

Order Information

Telescopic slides with guiding profile for fitting in cabinets

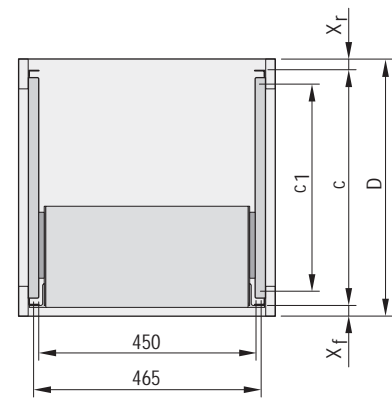

bza45819

Description	Depth D	x _f	x _r	C	c1	Part no.
	mm	mm	mm	mm	mm	
VARISTAR	600	50	50	500	369	24562-464
VARISTAR	800	50	50	700	569	24562-466
VARISTAR	900	50	50	800	669	24562-467
VARISTAR	1000	50	50	900	769	24562-468
VARISTAR	1100	50	50	1000	869	24562-472
VARISTAR	1200	50	50	1100	969	24562-473
eurorack	600	60	60	480	397	24562-449
eurorack	800	60	60	680	597	24562-451
eurorack	900	60	60	780	697	24562-452
NOVASTAR	500	33	60	407	350	24562-460
NOVASTAR	600	33	60	507	450	24562-461
NOVASTAR	800	33	60	707	650	24562-474
Lab rack	250	0	0	250	162	24562-446

x_f, x_r: Distance of 19" plane to cabinet edge (front, rear)
 c: Distance of 19" planes from each other,
 c1: Fixing dimension of guiding profile on 19" panel/slide mounts

Order Information

Telescopic slides with adaptor rail for subracks

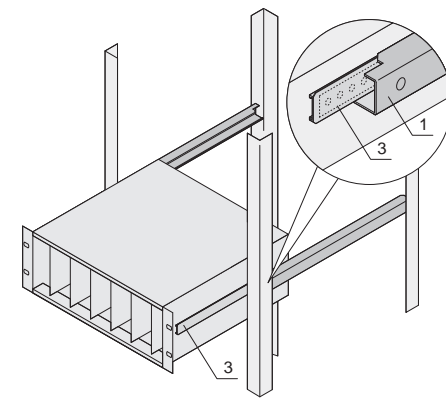

bza45819

For subrack depth	Part no.
mm	
175	24562-453
235	24562-454
295	24562-455
355	24562-456
415	24562-457
475	24562-458

Assembly parts

- Quick-release fasteners
- Sleeves
- Screws
- Cage nuts
- Tools

Quick-release fasteners

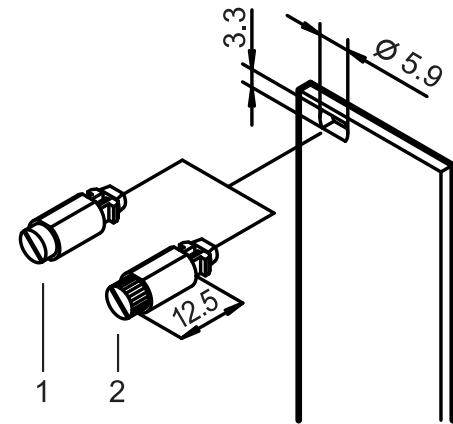

- Vibration and shock proof
- 1/4 rotary lock with defined stop
- Detection of locking position through slot position

Delivery comprises

Qty	Description
1	Locking pin, St, locking, Zn die-cast
1	Press-in sleeve, POM

Order Information

Item	Description	Qty/PU	Part no.
1	With slotted head, grey	100	21101-847
1	With slotted head, black	100	21101-848
2	With knurled and slotted head, grey	100	21101-849
2	With knurled and slotted head, black	100	21101-850

Note

Quick-release fasteners: mounting without threaded inserts

Sleeves

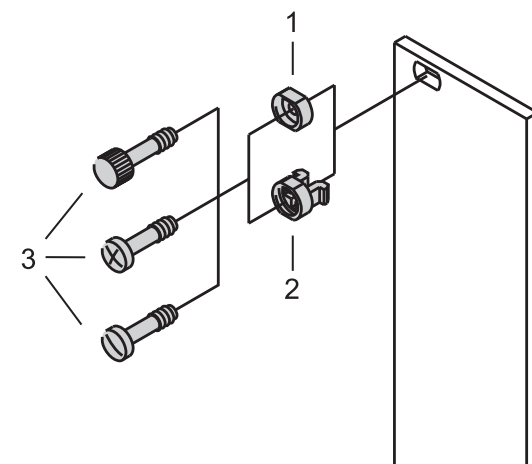

Order Information

Item	Description	Qty/PU	Part no.
2	Plastic sleeve, PA, grey	100	21100-464
2	Plastic sleeve, PA, black	100	21100-591
1	Metal sleeve, brass, nickel-plated	10	21100-659
1	Metal sleeve, brass, nickel-plated	100	21100-660
1	Metal sleeve, brass, black	100	21100-886
1	Metal sleeve, stainless steel	10	21100-661
1	Metal sleeve, stainless steel	100	21100-662

Note

- Metal sleeves must be pressed-in in front panels
- Sleeve does not fit in 2 HP wide front panels

Subracks - *europacPRO* ServicePLUS

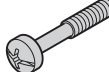
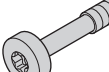
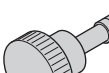

Collar screws

Order Information

Description	Application	Material	Dimension	Qty/PU	Part no.
 Collar screw with pozidrive/slot <small>AZA46586</small>	For mounting of front panels when using threaded inserts	St, nickel-plated	M2.5 x 12.3	100	21101-101
		St, zinc-plated, black	M2.5 x 12.3	100	21101-102
 Torx collar screw <small>AZA45941</small>	For mounting of front panels when using threaded inserts	St, nickel-plated	M2.5 x 12.3	100	21101-782
		St, zinc-plated, black	M2.5 x 12.3	100	21101-783
 Collar screw with knurled head <small>AZA45929</small>	For mounting of front panels when using threaded inserts	Brass, nickel-plated	M2.5 x 12.3	100	21101-749
	For mounting of front panels when using threaded inserts for horizontal rails with long lip	Brass, nickel-plated	M2.5 x 12.3	100	21101-909

Torx screws, self-forming

Order Information

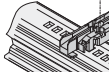
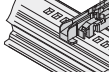
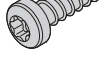
Description	Application	Material	Dimension	Qty/PU	Part no.
 Torx panhead screw, self-forming <small>06707058</small>	For extra-robust Al guide rails; torque max. 0.2 Nm	St, zinc flake coating, black	2.5 x 7.3	100	24560-157
 Torx countersunk screw, self-forming <small>06707058</small>	For 4.4" board height, guide rail on horizontal rail, europacPRO, ratiopacPRO; torque max. 0.2 Nm	St, zinc-plated	2.5 x 7.7	100	24560-158
 Torx panhead screw, self-forming <small>06707058</small>	For plastic guide rail on horizontal rail; for panel bracket on horizontal rail; torque max. 0.2 Nm	St, zinc-plated	2.5 x 9.3	100	24560-141
 Torx panhead screw, self-locking <small>06707058</small>	For plastic guide rails on horizontal rails	St, zinc-plated	2.5 x 9.3	100	21500-039
 Torx panhead screw <small>06707058</small>	For 6 U support member, backplane mounting, centre horizontal rail	St, zinc-plated	2.5 x 10	100	24560-179

Subracks - *europacPRO* ServicePLUS



Countersunk screws

Order Information

Description	Application	Material	Dimension	Qty/PU	Part no.
 Torx screw <small>AZA46585</small>	For support profiles europacPRO, ratiopacPRO	St, zinc-plated	M4 x 5	100	24560-139
	For mixed board assembly and assembly of shortened horizontal rail on support member, with GND/earthing function	St, zinc-plated	M4 x 14	100	24560-145

Torx panhead screws

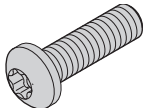
Order Information

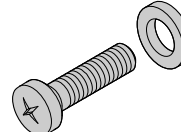
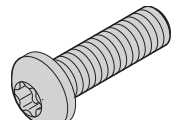
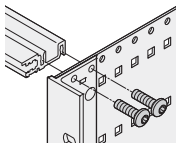
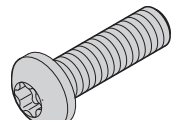
Description	Application	Material	Dimension	Qty/PU	Part no.
 Torx panhead screw <small>aza45940</small>	For Z-rails and connector assembly	St, nickel-plated	M2.5 x 7	100	24560-147
	For perforated rails	St, nickel-plated	M2.5 x 10	100	24560-148
	For backplane mounting	St, nickel-plated	M2.5 x 12	100	24560-161
		St, nickel-plated	M2.5 x 14	100	24560-162
 Washer <small>aza45178</small>	For insulated backplane mounting	Plastic, PA	2.8 x 6.3 x 2	100	21101-964
 Screw + plastic washer (PA) <small>aza45940</small>	For backplane mounting	St, nickel-plated	M2.5 x 12	100	21100-777
 Torx panhead screw <small>aza45940</small>	To bolt on support bracket, rear hood, corner profile on side panel, lengthening bracket and connecting bracket	St, zinc-plated	M4 x 6	100	24560-135
	To bolt-on cover plate or mounting plate, with GND/earthing function	St, zinc-plated	M4 x 6	100	24560-151
	To bolt-on cover plate or mounting plate, with GND/earthing function, self-forming thread	St, zinc-plated	M4 x 6	100	21101-884
 Torx panhead screw <small>06707058</small>	For horizontal rail on side panel if guide rails are bolted to slot 1	St, zinc-plated	M4 x 10	100	24560-155
	For horizontal rail on side panel, with GND/earthing function	St, zinc-plated	M4 x 14	10	24560-131
 Torx panhead screw <small>aza45940</small>	For horizontal rail on side panel, with GND/earthing function	St, zinc-plated	M4 x 14	100	24560-130

Subracks - *europac PRO* ServicePLUS

Grub screws

Order Information

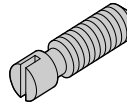
Description	Application	Material	Dimension	Qty/PU	Part no.
 <small>06702053</small> Grub screw	For threaded inserts M2.5 and perforated strips	Stainless steel	M2.5 x 9	100	21101-359
	For threaded inserts M2.5	St, nickel-plated	M2.5 x 8	100	21100-276
	For threaded inserts M3	St, zinc-plated	M3.0 x 8	100	21100-646

Square nuts

Order Information

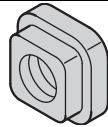
Description	Application	Material	Dimension	Qty/PU	Part no.
 <small>AZA45921</small> Square nut	For fixing: parts to side panels, support profiles, mounting plates	St, zinc-plated	M4	100	24560-140

Assembly kits

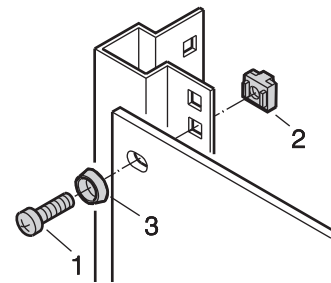

SC128XXX

- For assembly of subracks in cabinets or 19" cases
- For assembly of desk-top cases in cabinets by means of 19" brackets

Delivery comprises (kit)

Item	Qty	Description
1	1	Pozidrive screw M6 x 16, zinc-plated
2	1	Plastic washer, ABS, black
3	1	Cage nut M6, zinc-plated

Order Information

Description	Part no.
PU = 8 x screw, washer, nut	21100-435
PU = 50 each of M6 screw, washer and cage nut	21101-809
PU = 100 each of M6 screw, washer and cage nut	21101-810

- For 19" brackets with material thickness of 1.5 mm, see "Assembly kits" in chapter Cabinet accessories

Slide, to accomodate 2 nuts

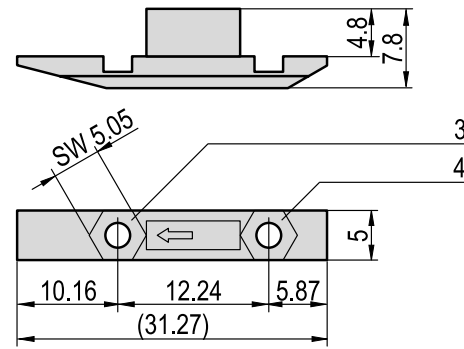
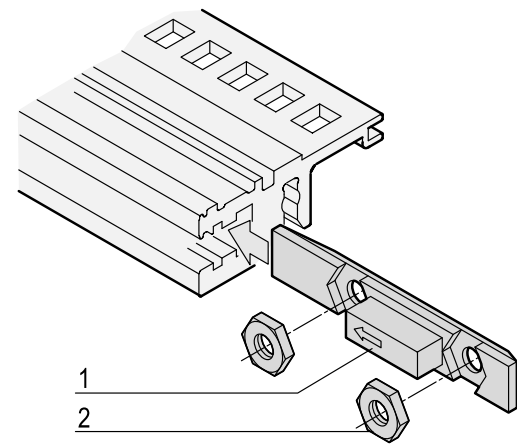

- The slide is pushed into the groove of the horizontal rail to front or rear (type VT)

Delivery comprises (kit)

Item	Qty	Description
1	1	Slide, PBT, red, UL 94 V-0
2	2	Nut, M2.5, St, zinc-plated

Order Information

Description		Part no.
Slide nut kit 1	100 slides/200 nuts	24560-165
Slide nut kit 2	12 slides/24 nuts	24560-166

Note

- Nuts used in item 3 suitable for:
 - hinged front panels, 84 HP
 - front or rear panels, 84 HP
- Nuts used in item 4 suitable for:
 - hinged front panels
- Nuts used in item 3 and 4 suitable for:
 - two front panels

 For further information www.schroff.biz/oneclick
oneClick search code = Part no.

06702060

Subracks - *europac* **PRO** ServicePLUS

Assembly tools

Order Information

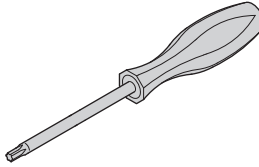
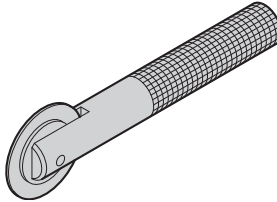
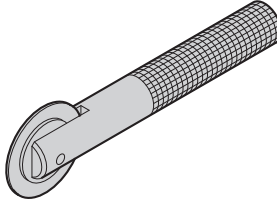
Description	Application	Dimension	Qty/PU	Part no.
 Torx screwdriver	T 8 torx	T8	1	64560-026
	T 20 torx	T20	1	64560-027
 Assembly tool	Exclusively to fix stainless steel EMC gaskets in horizontal rails	—	1	24560-271
 Assembly tool	To fix stainless steel EMC gaskets on front panels with lateral slots	—	1	24560-270

Note

- Assembly tool to insert keying/coding pegs in guide rails is available on request

Tape measure

- Measuring tape with cm, U-, HP-division (length 2 m)
- Plastic housing, metal measuring tape with automatic collection

Order Information

Description	Qty/PU piece	Part no.
Tape measure	1	89009-001

For further information www.schroff.biz/oneclick
 oneClick search code = Part no.

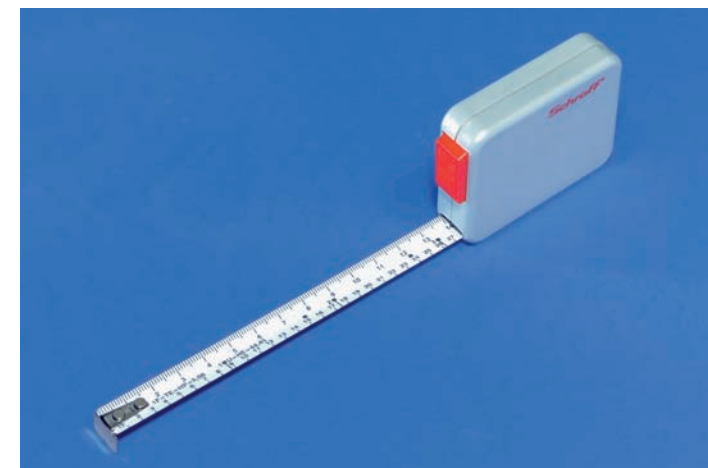

32506001

Application examples

Application: Transportation/defense sectors



- Mounting frame to accommodate a 36 HP wide railway subrack, frame from stainless steel

- Robust assembly by double bolt-on fixing
- Lateral ducting in cabinet
- Combined mounting 6 U+ 2 x 3 U

Application: Measurement, control and instrumentation sectors

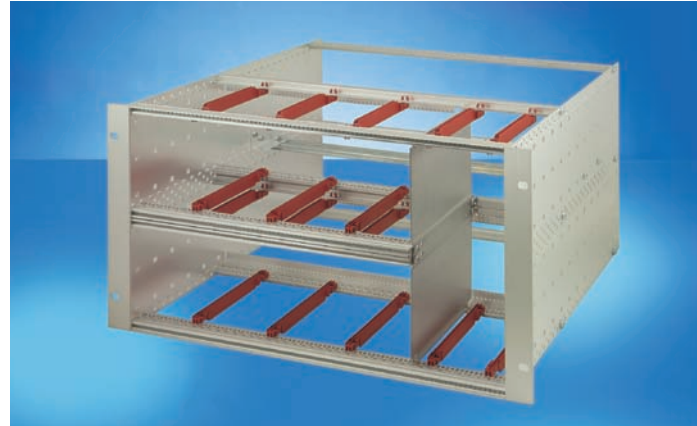

- Combined mounting with 2 x 3 U in 6 U
- Divider plate to separate different sections
- Installation with strengthened guide rails

- Subrack with additional telescopic fan unit
- Adaptation at bottom and top integrated into the side panel

Application: Telecoms sectors



- Shielded subrack for special applications with mounting plate, cover and base plate
- Mounting plate for heavy assemblies

- Subrack with plastic cable ducting for fibre optic cables
- Terminal area at top

Overview 0

Cabinets 1

Wall mounted cases 2

Accessories for cabinets and wall mounted cases 3

Climate control 4

Desk-top cases 5

**Subracks/
19" chassis ... 6**

Front panels,
plug-in units .. 7

Systems 8

Power supply
units 9

Backplanes .. 10

Connectors, front
panel component
system 11

Appendix 12

Subracks - for railway applications

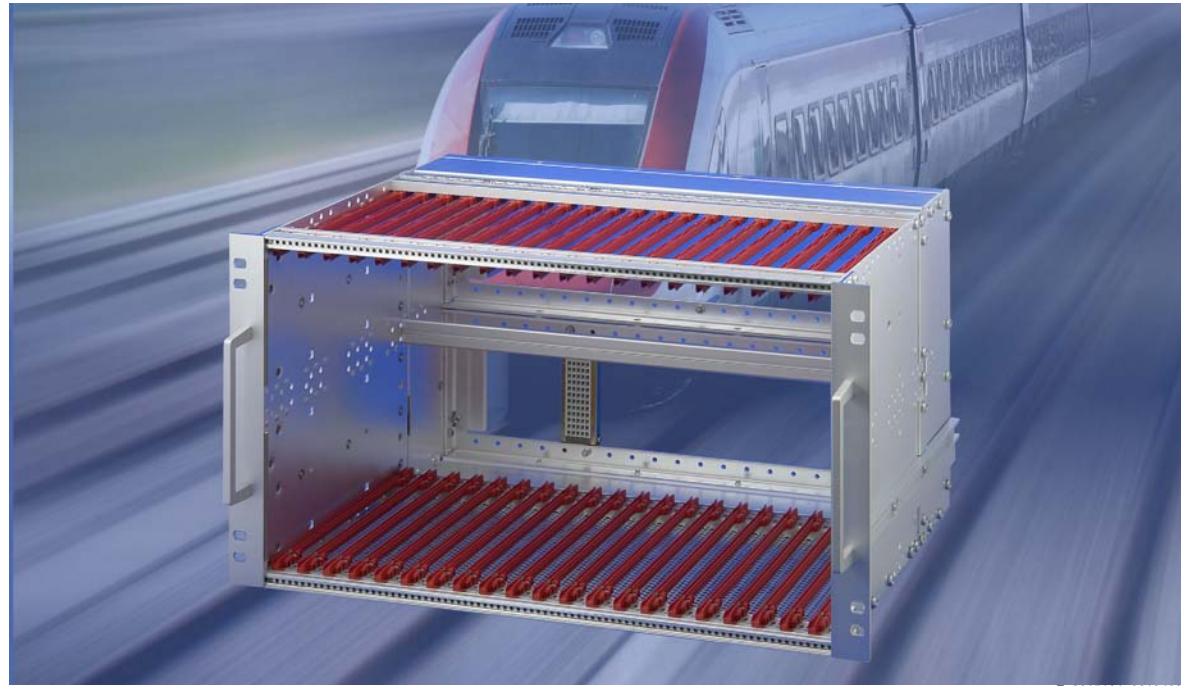

F_2015161_06104008

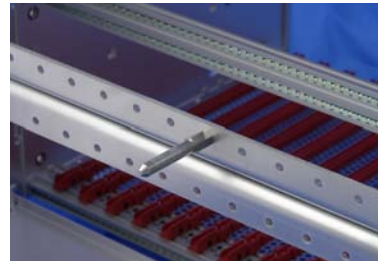

06108013

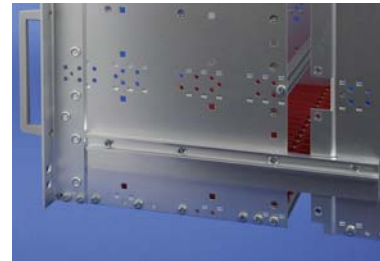

06108014



06108015

An alignment pin to NFF standard allows the easy installation of the subracks

Lateral support bars to NFF standard facilitate insertion of subrack into the (cabinet) frame

The 19" bracket is firmly fixed to the side panel (toxic-cold welded) and is especially suited for high mechanical stresses (vibration resistance)



06108016



06108017



06108015

The double 19" screwing position adds to additionally safety (NFF standard)

The cut-out in the side panel allows to retrofit the threaded insert, also if the side panels are already assembled

The rear brackets have two functions:
- push-in aid and
- transport protection for the connectors
The removable rear hood allows a fast cabling between backplane and connector



Downloads and further important information can be found on the Internet under www.schroff.biz

19" subrack for mobile rail applications

- Shock and vibration resistance to IEC 61587-1, EN 50155, NF F 61-005 / NF F 60-002, BN 411002 and BN 411003
- Versions for CompactPCI applications
- Best suited for high mechanical demands

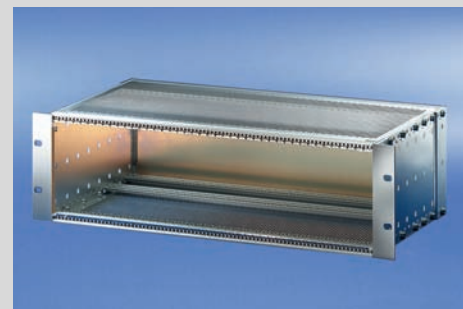

BN 411002, 411003 subracks

- Height 3 U and 6 U
- Width 84 HP
- Unshielded and shielded versions



BN 411002/003 subracks
 unshielded 6.73
 shielded 6.74



EN 50155 subrack

- Height 3 U and 6 U
- Width 84 HP
- Unshielded and shielded versions
- Shielded versions for CompactPCI applications

EN 50155 subracks
 unshielded 6.75
 shielded 6.76
 shielded, for CompactPCI 6.77



SNCF subrack

- Height 3 U and 6 U
- Width 9 T (36 HP) and 21 T (84 HP)
- Unshielded and shielded versions
- Shielded versions for CompactPCI applications



SNCF subracks
 unshielded 6.78
 shielded 6.79
 shielded, for CompactPCI 6.80

Accessories
 Guide rails 6.81
 Cover plates 6.82
 General accessories in europacPRO section 6.17

ServicePLUS . . 6.84
 Application examples 6.85

europacPRO 6.6
 europacPRO for industrial applications 6.86
 europacPRO for rugged applications 6.92

ServicePLUS from page 6.84

- e.g. modification (cut-outs)
- e.g. downloads (CAD drawings, user manuals, test reports)
- e.g. custom solutions (special depths, electromagnetically shielded applications)

www.schroff.biz/ServicePLUS



Subracks - *europac PRO* for railway applications

Subrack for mobile rail applications



Solid mechanical construction
Electronics for mobile applications require robust mechanical construction that can withstand extreme environmental conditions. Our enclosure solutions protect the housed electronics thanks to their high mechanical strength and thus are an important element for secure and trouble-free operation of the entire system. Only dependability, down to the last detail, can make complex safety tasks achievable - and also economic.

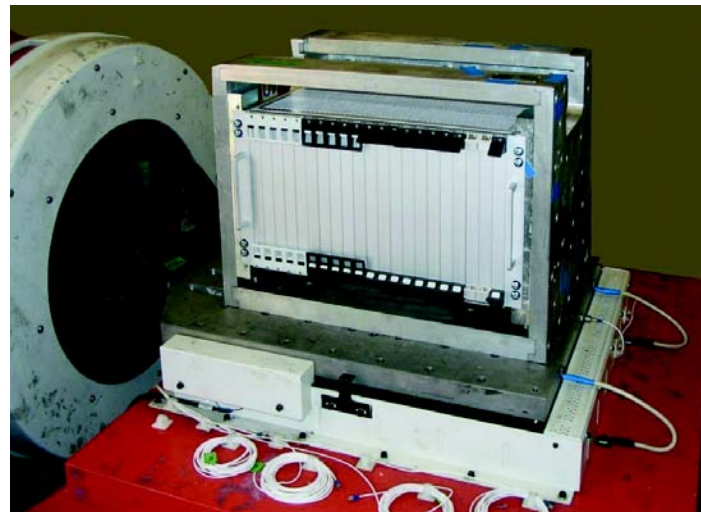

Shock and vibration resistance
Schroff products assure shock and vibration resistance in mobile applications e.g. by suitable material thicknesses and fixing elements. Tested with typical loads, they offer the best conditions for secure and reliable functioning in individual applications and projects.

Certification of mechanics
High-quality, robust and durable products are an important component for the certification of a complete application in accordance with the European Railway Standard DIN EN 50155, the German Railway Standards BN 411002 and BN 411003 and the French Railway Standards NF F 61-005 and NF F 60-002.

Note
fer = ferroviaire (French) = railway
1 T = 4 HP = 20.32 mm



Railway Technology brochure
A large amount of general information on our railway systems solutions can be found at www.schroff.co.uk/railway/ and in our "Railway Systems" brochure.

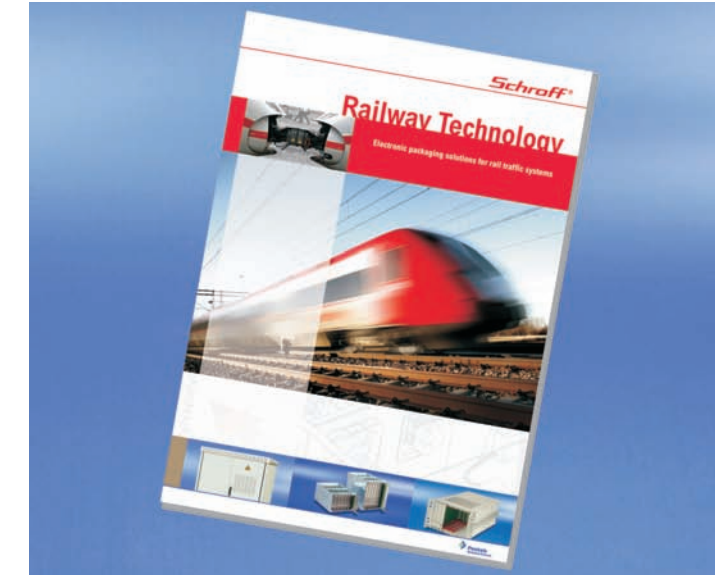

TÜV test report

Subracks - **europac PRO** for railway applications

Kit, unshielded, 'heavy',
for backplane mounting



NEW

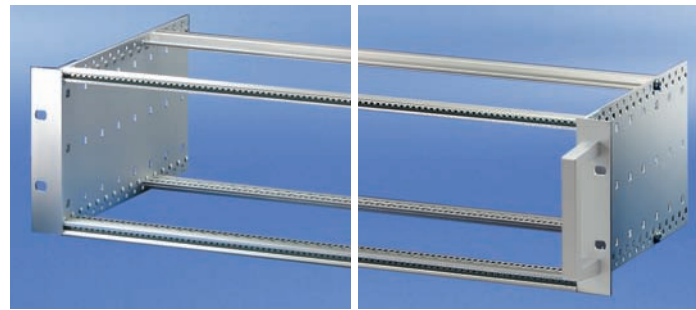

Without front handle

With front handle

- Subrack with side panel type H ("heavy"), 19" bracket is firmly connected to side panel (tox-cold welded)
- Rear horizontal rail for backplane mounting with insulation strip
- Tested to German Railway Standards BN 411002, BN 411003
- Versions with/without front handles

Delivery comprises (Kit)

Item	Qty	Description	
	3 U	6 U	
1	2	2	Side panel type H, Al, 2 mm, passivated, with 19" support bracket (tox-cold welded) for textile EMC gasket
2a	2	2	Front horizontal rail (H-KD)
2b	2	2	Rear horizontal rail (H-ST)
2c	-	1	Rear horizontal rail centre (H-ST)
3	4	6	Threaded inserts, front and rear (pre-fitted)
4	2	4	Insulation strip (pre-fitted)
5	1	1	Fixing material kit, user manual
6	2	2	Front handle (on version with front handle only)

Order Information

Height U	Width HP	Depth D mm	Depth D1 mm	Part no. with front handle	Part no. without front handle
3	84	175	175	24567-161	24563-161
3	84	235	175/235	24567-162	24563-162
3	84	295	175/235/295	24567-163	24563-163
3	84	355	175/235/295/355	24567-164	24563-164
6	84	175	175	24567-461	24563-461
6	84	235	175/235	24567-462	24563-462
6	84	295	175/235/295	24567-463	24563-463
6	84	355	175/235/295/355	24567-464	24563-464

Accessories

19" assembly kit (screw, washer, nut) (8 x screws, 8 x plastic washers, 8 x cage nuts) 21100-435

Guide rails (standard), ESD clips

Depth D2 mm	Qty/PU pieces	Part no.
160	10	24560-351
220	10	24560-353
280	10	24560-379
340	10	24560-380

ESD clip for guide rails PU 50 pieces 24560-255

Torx panhead screw, for extra bolting of the guide rails, 2.5 x 9.3, zinc-plated, PU 100 pieces 24560-141

Note

- Perforated rails, cover plates and assembly kit from page 6.34
- Textile EMC gaskets see page 6.21
- Further accessories from page 6.17
- ServicePLUS configuration from page 6.84

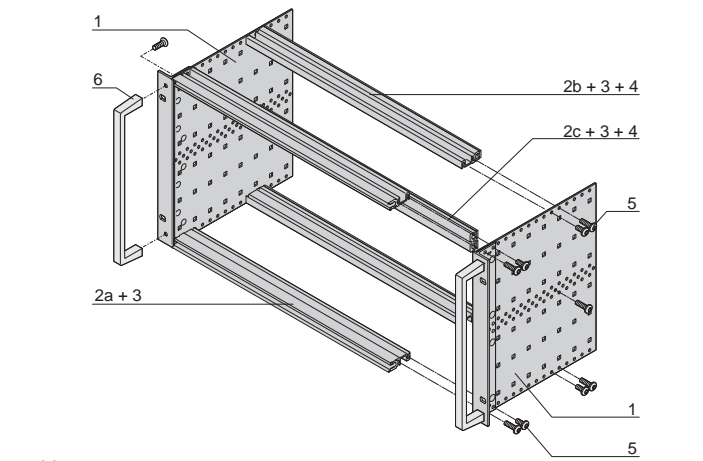

6 U

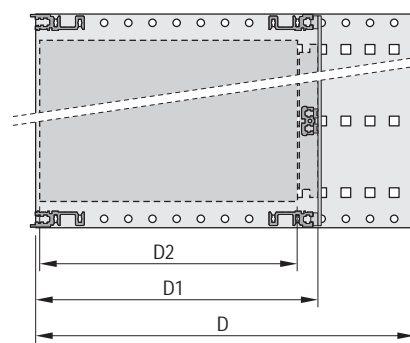

D=overall depth, D1=insertion depth,
D2=board depth = D1 - 15 mm



Rear horizontal rail for backplane mounting with insulation strip



ServicePLUS see page 6.84



For further information www.schroff.biz/oneclick
oneClick search code = Part no.

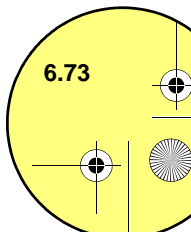

Subracks - *europac PRO* for railway applications

Kit, shielded, "heavy", for backplane mounting

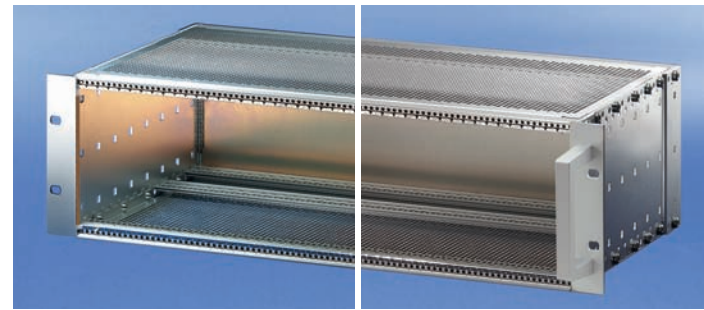

- Subrack with side panel type H ("heavy"), 19" bracket is firmly connected to side panel (tox-cold welded)
- Horizontal rail rear for backplane mounting with insulating strip
- Shielding typically 40 dB at 1 GHz, 30 dB at 2 GHz (in accordance with VG 95373, part 15 or IEC 61587, part 3), under the condition that the front is closed with shielded front panels
- Tested to German Railway Standards BN 411002, BN 411003
- Versions with/without front handles



NEW

Delivery comprises (Kit)

Item	Qty	Description	
	3 U	6 U	
1	2	2	Side panel type H, Al, 2 mm, passivated, with 19" support bracket (tox-cold welded); for textile EMC gasket
2	2	2	Rear corner profile for textile EMC gasket
3	2	2	Front horizontal rail (H-KD)
3 a	2	2	Rear horizontal rail (H-KD)
3 b	2	2	Rear horizontal rail (H-ST)
3 c	-	1	Rear horizontal rail centre (H-ST)
4	6	8	Threaded insert (pre-fitted)
5	2	2	Perforated strip (pre-mounted)
6	2	4	Insulation strip (pre-fitted)
7	2	2	EMC cover plate
8	1	1	EMC gasketing material (pre-fitted)
9	1	1	EMC rear panel
10	1	1	Fixing material kit, user manual
11	2	2	Front handle (on version with front handle only)

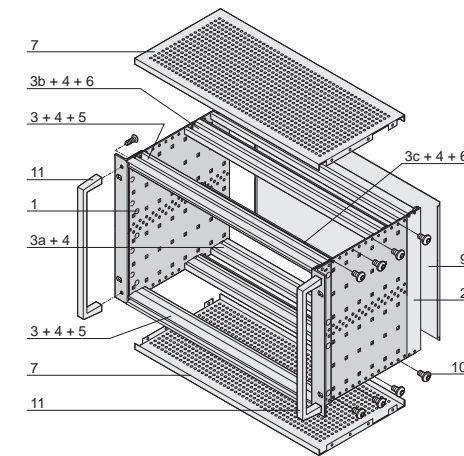

0611058

Order Information

Height U	Width HP	Depth D mm	Depth D1 mm	Part no. with front handle	Part no. without front handle
3	84	235	175/235	24567-172	24563-172
3	84	295	175/235/295	24567-173	24563-173
3	84	355	175/235/295	24567-174	24563-174
6	84	235	175/235	24567-472	24563-472
6	84	295	175/235/295	24567-473	24563-473
6	84	355	175/235/295	24567-474	24563-474

Accessories

19" assembly kit (screw, washer, nut) (8 x screws, 8 x plastic washers, 8 x cage nuts) 21100-435

Guide rails (standard), ESD clips

Depth D2 mm	Qty/PU pieces	Part no.
160	10	24560-351
220	10	24560-353
280	10	24560-379

ESD clip for guide rails PU 50 pieces 24560-255
Torx panhead screw, for extra bolting of the guide rails, 2.5 x 9.3, zinc-plated, PU 100 pieces 24560-141

- Perforated rail for connectors see page 6.34
- Further accessories from page 6.17
- ServicePLUS configuration from page 6.84

Without front handle 0611008 With front handle 0611001

6 U

0610860

D = overall depth, D1 = insertion depth, D2 = board depth = D1 - 15 mm



Rear horizontal rail for backplane mounting with insulation strip



ServicePLUS see page 6.84

Subracks - *europac* PRO for railway applications

Kit, EN 50155, unshielded

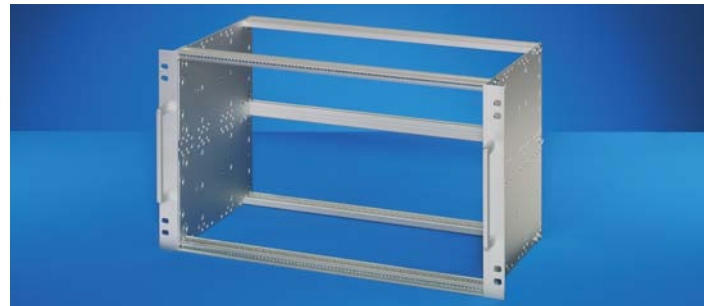

- Subrack in robust "heavy" version, 19" bracket is firmly connected to side panel (tox-cold welded)
- For mobile railway applications
- Tested to EN 50155
- 3 U and 6 U, 84 HP, 235 mm deep, for 220 mm board depth

Delivery comprises (kit)

Item	Qty	Description	
	3 U	6 U	
1	2	2	Side panel type H with 19" support bracket (tox-cold welded); prepared for EMC textile gasket
2	2	2	Front horizontal rail (H-KD)
2 a	2	2	Rear horizontal rail (H-VT)
2 b	-	1	Rear centre horizontal rail (VT)
3	4	6	Threaded inserts
4	2	2	Handles
5	1	1	Assembly kit with self-locking screws
6	1	1	User manual

Order Information

Height	Width	Depth	Part no.
U	HP	mm	
3	84	235	21500-077
6	84	235	21500-078

Accessories

Guide rail, standard, 220 mm deep PBT, UL 94 V-0, red, groove width 2 mm, PU 10 pieces, see page 6.36	24560-353
Panhead screw with Torx M2.5 x 9.3, St, zinc-plated, self-locking, PU 100 pieces	21500-039
ESD clip for guide rails PU 50 pieces	24560-255
Cover plate for screw-fixing onto side panel width 84 HP, depth 220 mm, PU 1 kit	21500-037
19" dual fixing materials kit suitable for a subrack with double fixing holes (bolts, washers and nuts), PU 1 kit	24566-109

Note

- Test reports online
- ServicePLUS configuration see from page 6.84
- Further accessories see from page 6.17



For further information www.schroff.biz/oneclick
oneClick search code = Part no.

3 U

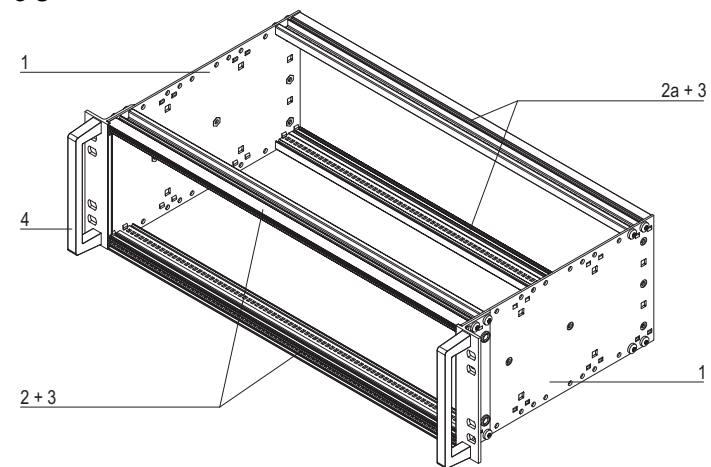

06104005

06104056

6 U

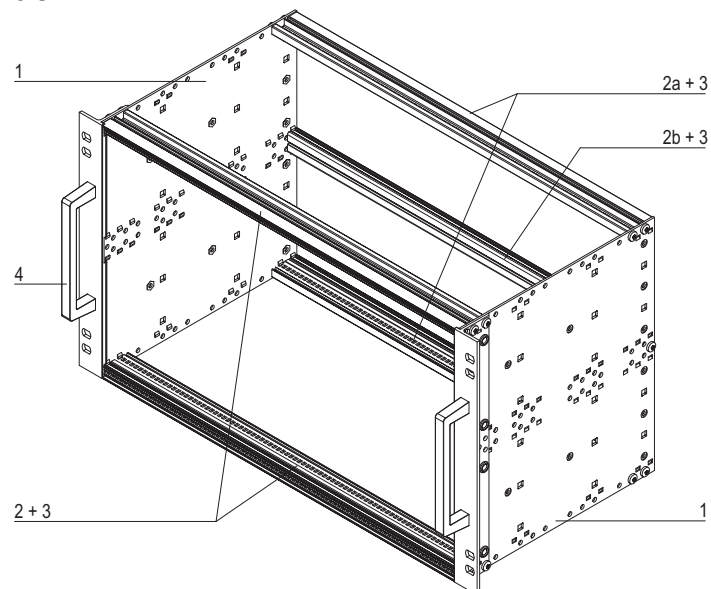

06104057



ServicePLUS see page 6.84

Subracks - *europac* PRO for railway applications

Kit, EN 50155, shielded



- Subrack in robust "heavy" version, 19" bracket is firmly connected to side panel (tox-cold welded)
- For mobile railway applications
- Tested to EN 50155
- 3 U and 6 U, 84 HP, 235 mm deep, for 220 mm board depth

Delivery comprises (kit)

Item	Qty	Description
3 U 6 U		
1	2 2	Side panel type H with 19" support bracket (tox-cold welded); for textile EMC gasket
2	2 2	Front horizontal rail (H-KD)
2 a	2 2	Rear horizontal rail (H-VT)
2 b	- 1	Rear centre horizontal rail (VT)
3	4 6	Threaded inserts
4	2 2	Perforated strip
5	2 2	EMC cover plate 235 T
6	1 1	EMC gasketing kit
7	1 2	Backplane kit – EMC shielding material
8	2 2	Handles
9	1 1	Assembly kit with self-locking screws
10	1 1	User manual

Order Information

Height	Width	Depth	Part no.
U	HP	mm	
3	84	235	21500-079
6	84	235	21500-080

Accessories

Guide rail, standard, 220 mm deep PBT, UL 94 V-0, red, groove width 2 mm, PU 10 pieces, see page 6.36	24560-353
Panhead screw with Torx M2.5 x 9.3, St, zinc-plated, self-locking, PU 100 pieces	21500-039
ESD clip for guide rails PU 50 pieces	24560-255
19" dual fixing materials kit suitable for a subrack with double fixing holes (bolts, washers and nuts), PU 1 kit	24566-109

Note

- Test reports online
- ServicePLUS configuration see from page 6.84
- Further accessories see from page 6.17

 For further information www.schroff.biz/oneclick
oneClick search code = Part no.

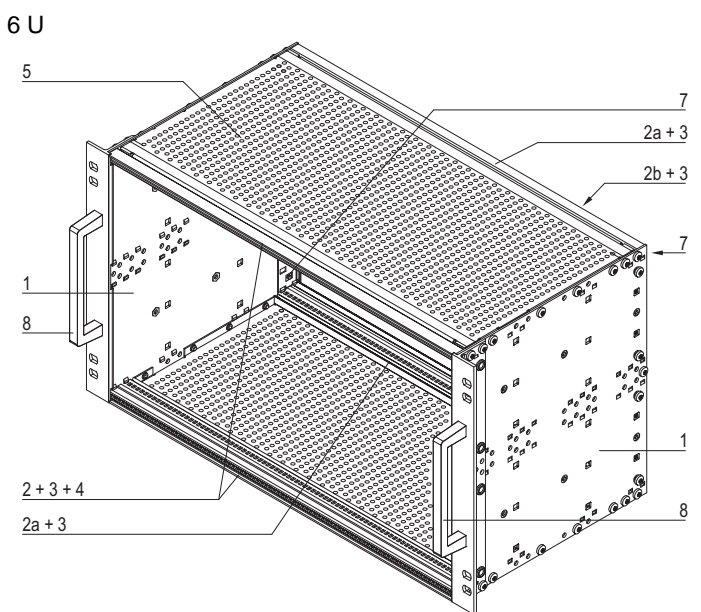
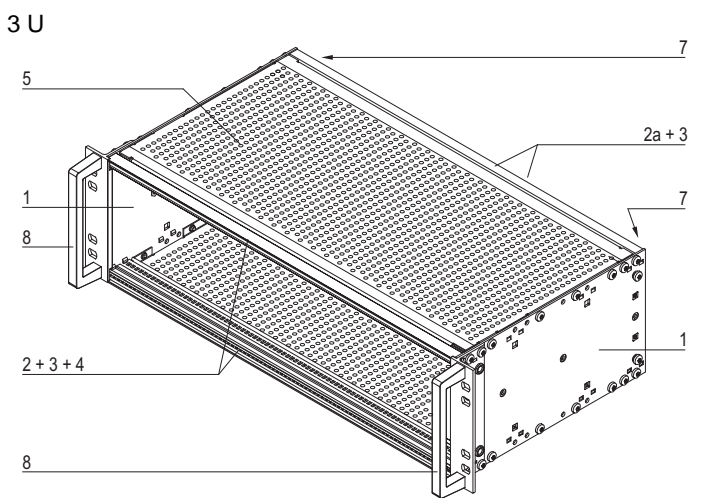

ServicePLUS see page 6.84

Subracks - *europac*PRO for railway applications

Kit, EN 50155, shielded, for CompactPCI applications



- Subrack in robust "heavy" version, 19" bracket is firmly connected to side panel (tox-cold welded)
- For mobile railway applications
- Tested to EN 50155
- 3 U and 6 U, 84 HP, 235 mm deep, for 160 mm board depth
- Subrack in accordance with IEEE 1101.10

Delivery comprises (kit)

Item	Qty	Description
3 U 6 U		
1	2 2	Side panel type H with 19" support bracket (tox-cold welded); for textile EMC gasket
2	1 -	Front horizontal rail (H-KD)
2 a	2 2	Rear horizontal rail (H-VT)
2 b	- 1	Rear centre horizontal rail (VT)
2 c	1 2	Front horizontal rail (H-LD)
3	4 6	Threaded inserts
4	2 2	Perforated strip
5	2 2	EMC cover plate, 175 T
6	1 1	EMC gasketing kit
7	1 2	Backplane kit – EMC shielding material
8	2 2	Handles
9	1 1	Assembly kit with self-locking screws
10	1 1	User manual

Order Information

Height	Width	Depth	Part no.
U	HP	mm	
3	84	235	21500-081
6	84	235	21500-082

Accessories

19" dual fixing materials kit suitable for a subrack with double fixing holes (bolts, washers and nuts), PU 1 kit	24566-109
--	-----------

Note

- Please order guide rails and ESD clips separately, see page 6.81
- Test reports online
- ServicePLUS configuration see from page 6.84
- Further accessories see from page 6.17



For further information www.schroff.biz/oneclick
oneClick search code = Part no.

3 U

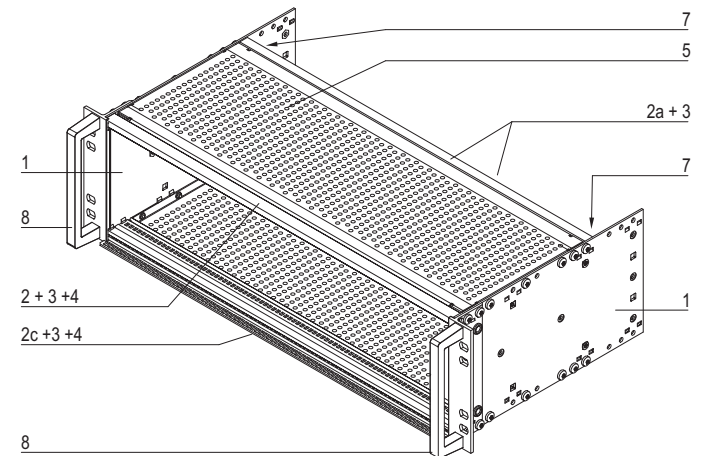

06104007

06104060

6 U

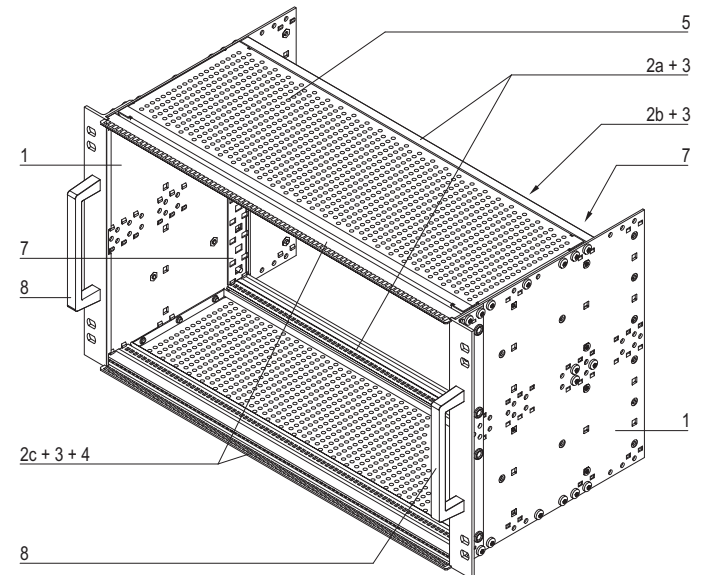

06104061



ServicePLUS see page 6.84

Subracks - *europacPRO* for railway applications

Kit, SNCF, unshielded

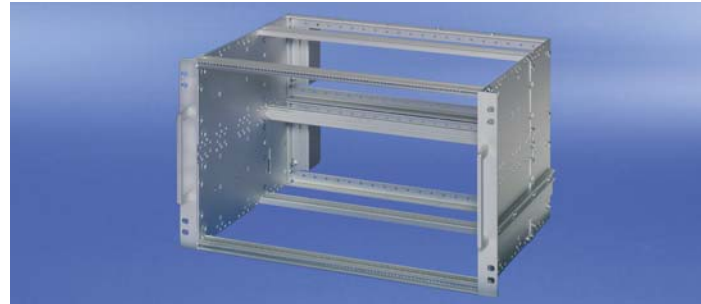

- Subrack, robust "heavy" version, 19" bracket is firmly connected to side panel (tox-cold welded)
- For mobile railway applications
- SNCF listed, europacPRO-fer, tested to NF F 61-005 and NF F 60-002
- 3 U and 6 U, 9 HP and 21 HP, 320 mm deep, for 220 mm board depth



Delivery comprises (kit)

Item	Qty	Description	
	3 U	6 U	
1	2	2	Side panel type H with 19" support bracket (tox-cold welded); prepared for textile EMC gasket
2	2	2	Side panel extension
3	2	2	Ducting external
4	2	2	Front horizontal rail (H-KD)
4 a	2	2	Rear horizontal rail (H-VT)
4 b	-	1	Rear centre horizontal rail (VT)
5	4	6	Threaded inserts
6	1	2	Rear frame 3 U, 21 T
7	2	4	Protective bracket SNCF
8	2	2	Handle
9	1	1	Assembly kit with self-locking screws
10	1	1	User manual

Order Information

Width	Height	Depth	Part no.
mm	U	mm	
36 HP (9 T)	3	320	21500-067
36 HP (9 T)	6	320	21500-070
84 HP (21 T)	3	320	21500-029
84 HP (21 T)	6	320	21500-027

Accessories

Guide rail, standard, 220 mm deep PBT, UL 94 V-0, red, groove width 2 mm, PU 10 pieces, see page 6.36	24560-353
Panhead screw with Torx M2.5 x 9.3, St, zinc-plated, self-locking, PU 100 pieces	21500-039
ESD clip for guide rails PU 50 pieces	24560-255
Coding peg for rear frame, St, white zinc-plated, 1 piece	60895-018
19" dual fixing materials kit suitable for a subrack with double fixing holes (bolts, washers and nuts), PU 1 kit	24566-109

Note

- fer = ferroviaire = French Railways, 1 T = 4 HP = 20.32 mm
- Receptacle/mounting frame for subracks, stainless steel, 9 T or 21 T on request
- Test reports online
- Cover plates for bolting on to side panel see page 6.82
- ServicePLUS configuration see from page 6.84
- Further accessories see from page 6.17

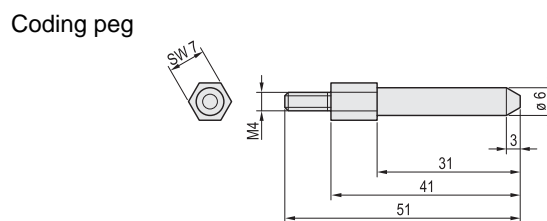
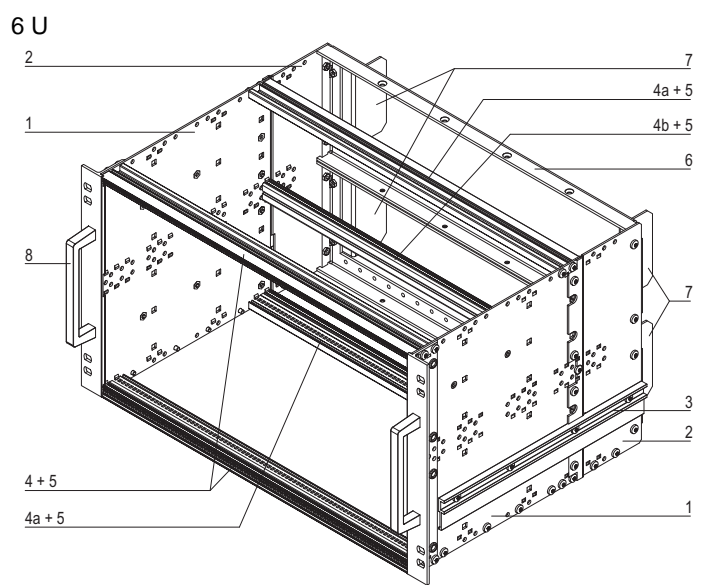
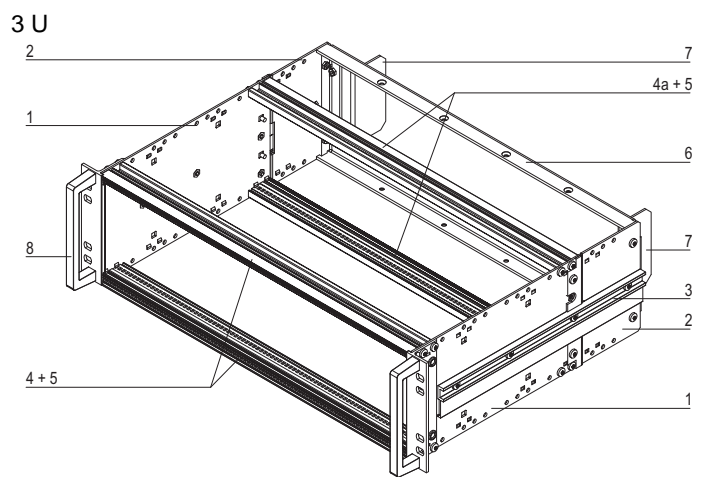

ServicePLUS see page 6.84



For further information www.schroff.biz/oneclick
oneClick search code = Part no.

Subracks - *europacPRO* for railway applications

Kit, SNCF, shielded



- Subrack, robust "heavy" version, 19" bracket is firmly fixed to side panel (tox-cold welded)
- For mobile railway applications
- SNCF listed, europacPRO-fer, tested to NF F 61-005 and NF F 60-002
- 3 U and 6 U, 9 T and 21 T, 320 mm deep, for 220 mm board depth



Delivery comprises (kit)

Item	Qty	Description
		3 U 6 U
1	2 2	Side panel type H with 19" support bracket (tox-cold welded); for textile EMC gasket
2	2 2	Side panel extension
3	2 2	Ducting external
4	2 2	Front horizontal rail (H-KD)
4 a	2 2	Rear horizontal rail (H-VT)
4 b	- 1	Rear centre horizontal rail (VT)
5	4 6	Threaded inserts
6	2 2	Perforated strip
7	2 2	EMC cover plate 235 T
8	2 2	Rear cover plate, 55 T
9	1 1	EMC gasketing kit
10	1 2	Backplane kit – EMC shielding material
11	1 2	Rear frame, 3 U, 21 T
12	2 4	Protective bracket SNCF
13	2 2	Handles
14	1 1	Assembly kit with self-locking screws
15	1 1	User manual

Order Information

Width	Height	Depth	Part no.
		mm	
36 HP (9 T)	3	320	21500-068
36 HP (9 T)	6	320	21500-071
84 HP (21 T)	3	320	21500-030
84 HP (21 T)	6	320	21500-028

Accessories

Guide rail, standard, 220 mm deep PBT, UL 94 V-0, red, groove width 2 mm, PU 10 pieces, see page 6.36	24560-353
Panhead screw with Torx M2.5 x 9.3, St, zinc-plated, self-locking, PU 100 pieces	21500-039
ESD clip for guide rails PU 50 pieces	24560-255
Coding peg for rear frame, St, white zinc-plated, 1 piece	60895-018
19" dual fixing materials kit suitable for a subrack with double fixing holes (bolts, washers and nuts), PU 1 kit	24566-109

Note

- fer = ferroviaire = French Railways, 1 T = 4 HP = 20.32 mm
- Receptacle/mounting frame for subracks, stainless steel, 9 T or 21 T on request
- Test reports online
- ServicePLUS configuration see from page 6.84
- Further accessories see from page 6.17

3 U

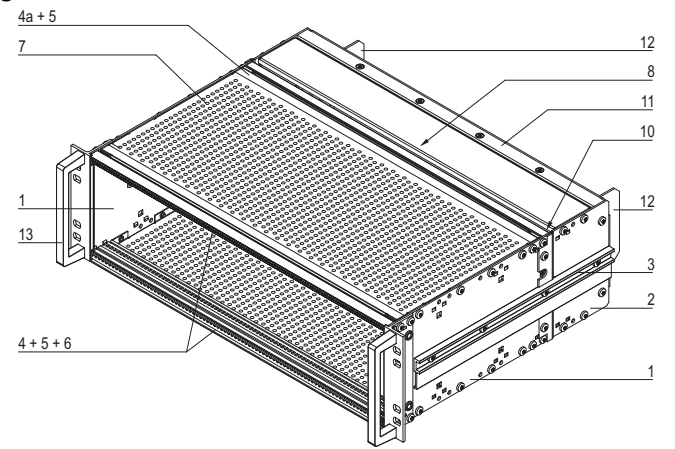

06104003

06104052

6 U

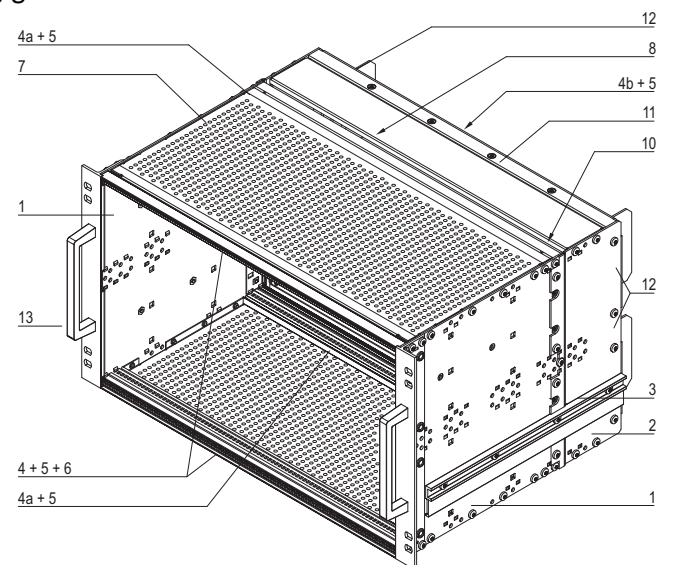

06104053

06104062

Coding peg

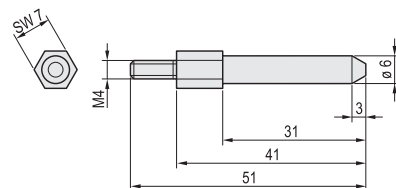

ServicePLUS see page 6.84

Subracks - *europacPRO* for railway applications

Kit, SNCF, shielded,
for CompactPCI applications



- Subrack, robust "heavy" version, 19" bracket is firmly fixed to side panel (tox-cold welded)
- For mobile railway applications
- SNCF listed, europacPRO-fer, tested to NF F 61-005 and NF F 60-002
- 3 U and 6 U, 9 HP and 21 HP, 320 mm deep, for 160 mm board depth
- CompactPCI subrack conforming to 1101.10



Delivery comprises (kit)

Item	Qty	Description	
	3 U	6 U	
1	2	2	Side panel type H with 19" support bracket (tox-cold welded); for textile EMC gasket
2	2	2	Side panel extension
3	2	2	Ducting external
4	1	-	Front horizontal rail (H-KD)
4 a	2	2	Rear horizontal rail (H-VT)
4 b	-	1	Rear centre horizontal rail (VT)
4 c	1	2	Front horizontal rail (H-LD)
5	4	6	Threaded inserts
6	2	2	Perforated strip
7	2	2	EMC cover plate, 175 T
8	2	2	Rear cover plate, 55 T
9	1	1	EMC gasketing kit
10	1	2	Backplane kit – EMC shielding material
11	1	2	Rear frame, 3 U, 21 T
12	2	4	Protective bracket SNCF
13	2	2	Handles
14	1	1	Assembly kit with self-locking screws
15	1	1	User manual

Order Information

Width	Height	Depth	Part no.
U			
36 HP (9 T)	3	320	21500-069
36 HP (9 T)	6	320	21500-072
84 HP (21 T)	3	320	21500-047
84 HP (21 T)	6	320	21500-046

Accessories

Coding peg for rear frame, St, white zinc-plated, 1 piece	60895-018
19" dual fixing materials kit suitable for a subrack with double fixing holes (bolts, washers and nuts), PU 1 kit	24566-109

Note

- Please order guide rails and ESD clips separately, see page 6.81
- fer = ferroviaire = French Railways, 1 T = 4 HP = 20.32 mm
- Receptacle/mounting frame for subracks, stainless steel, 9 T or 21 T on request
- Test reports online
- ServicePLUS configuration see from page 6.84
- Further accessories see from page 6.17

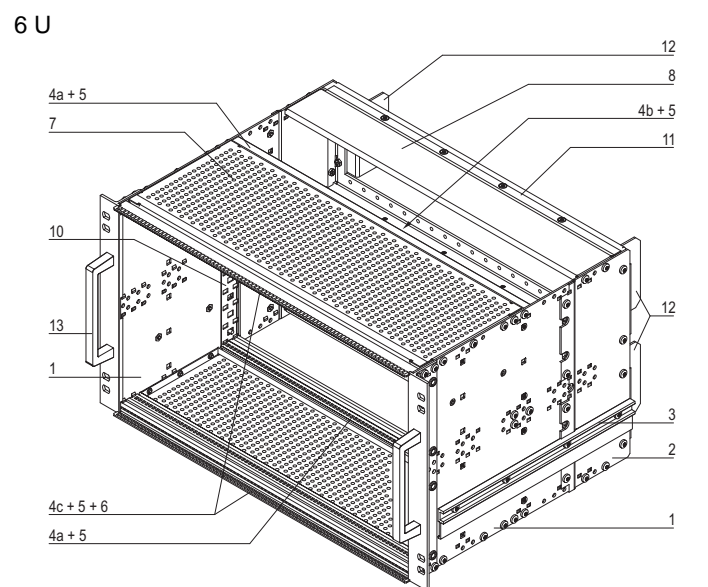
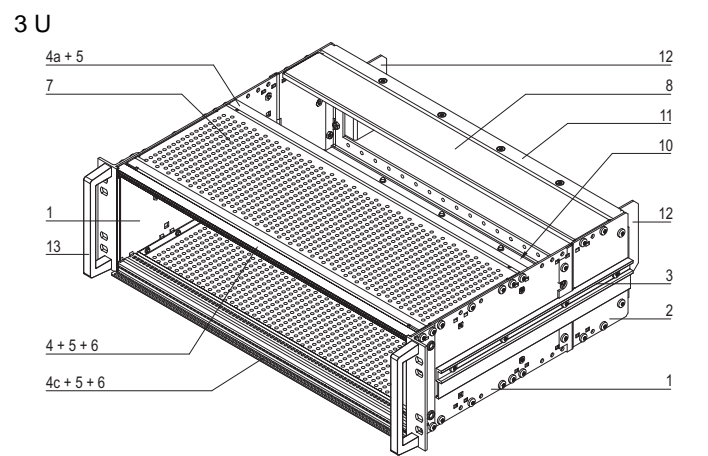

Coding peg

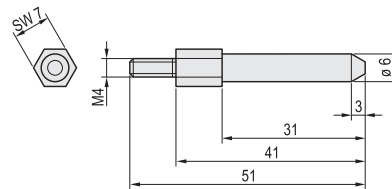

ServicePLUS see page 6.84



For further information www.schroff.biz/oneclick
oneClick search code = Part no.

Subracks - **europac PRO** for railway applications

Guide rails

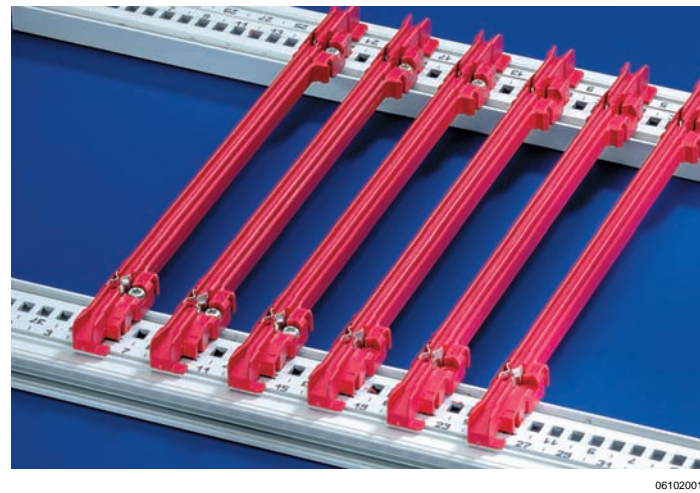

- Material PBT, UL 94 V-0, red, groove width 2 mm, for 1.6 mm board thickness

Order Information

Description	Depth mm	Qty/PU	Part no.
Guide rails, accessories, 160 mm deep	160	10	24560-351
Guide rails, standard, 220 mm deep	220	10	24560-353
ESD clip for guide rails PU 50 pieces			24560-255



For further information www.schroff.biz/oneclick
oneClick search code = Part no.

Guide rails with coding for CompactPCI and VME64x

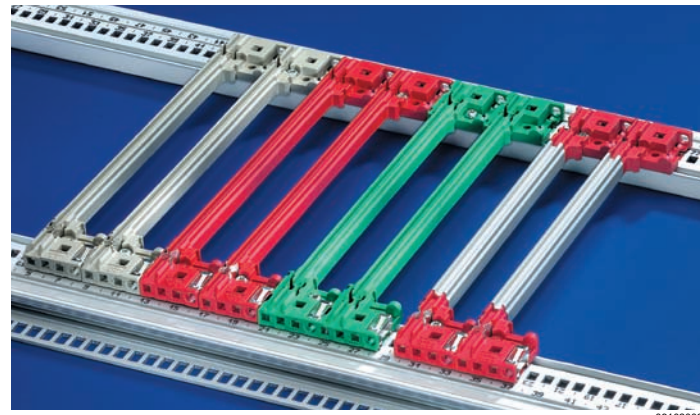

- The guide rails conform to IEC 60297-3-100 and IEEE 1101.10/11, are 4 HP wide and can be fitted with keying/coding pegs
- Material PBT UL 94 V-0, groove width 2 mm, for board thickness 1.6 mm
- Colour:
 - red (CPU board)
 - grey (periphery board)
 - green (CompactPCI power supply unit, 0.1" offset)

Order Information

Description	Depth mm	Qty/PU	Part no.
Guide rails with coding, red	160	10	24560-356
Guide rails with coding, grey	160	10	24560-358
Guide rails with coding, green, offset	160	10	24560-359

Panhead screw with Torx

M2.5 x 9.3, St, zinc-plated, self-locking,
PU 100 pieces

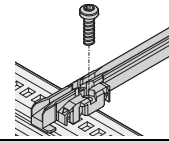

21500-039

ESD clip for guide rails PU 50 pieces

24560-255

ESD clip for alignment pin of CPC/VM64x handle

PU 50 pieces 24560-256

Coding peg PC, UL 94 V-0, RAL 7035, PU 100 pieces

20817-501

- More guide rails see page 6.36
- For inserter/extractor handle type IEL/IET for CompactPCI or VME64x applications see Subracks/Plug-in units section, page 7.18

Guide rails on horizontal rail type H

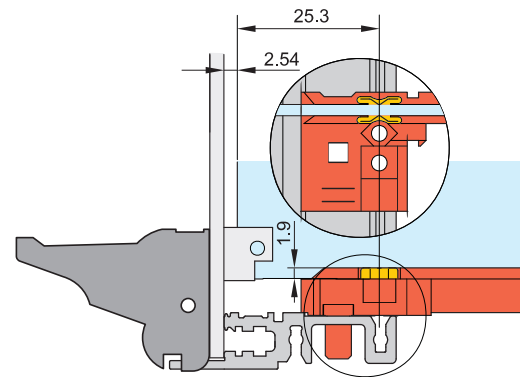

04505050

ESD clip for alignment pin

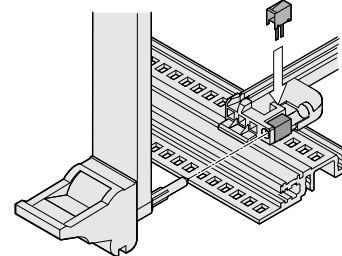

06103052

Subracks - *europac PRO* for railway applications

Cover plate for screw-fixing onto side panel

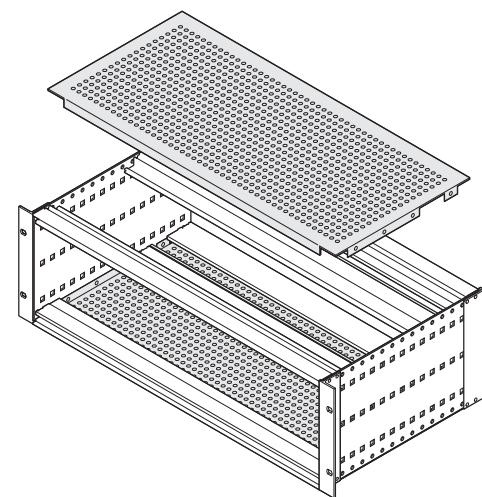

- Suitable for use with all horizontal rails
- Cover plate for mounting of 160 mm, 220 mm or 280 mm deep PCBs
- Lateral notch to mount the horizontal rails in depths of 160 mm or 220 mm
- Shielding by optional EMC stainless steel contact strips between cover plate and horizontal rail

Delivery comprises

Item	Qty	Description
1	2	Cover plate, Al, 1.0 mm, clear chromated, hole diameter 4.0 mm, (no perforation at 55 mm depth)
2	16/32	Torx M4 x 6 pentaform bolts, St, zinc-plated

Order Information

Width	Depth D	Application	Part no.
HP	mm		
84	55	-	21500-038
84	175	160	21500-048
84	235	160, 220	21500-037
36	55	-	21500-123
36	175	160	21500-124
36	220	160, 220	21500-122

Note

- 4 stainless steel EMC gaskets are necessary per subrack, see page 6.82

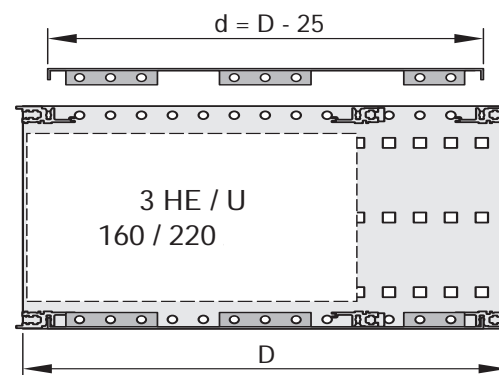

Side view for 175 mm and 235 mm depths

EMC gasket (stainless steel) between cover plate and horizontal rail

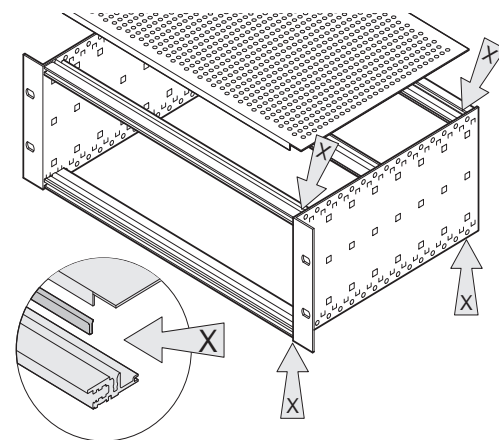

- Stainless steel gasket is clipped into horizontal rail and forms the contact cover plate
- Fits all horizontal rails

Order Information

Width	Length	Qty/PU	Part no.
HP	mm	pieces	
42	182.4	10	24560-241
63	284.0	10	24560-243
84	395.7	10	24560-245
84	395.7	100	24560-246
Assembly tool For mounting of EMC sealing, St, stainless, in horizontal rails, 1 piece			24560-271

Note

- When a rear hood is used, the stainless steel EMC gasket ensures the conductive connection between horizontal rail and rear hood

 For further information www.schroff.biz/oneclick
oneClick search code = Part no.

aza45938

Assembly tool

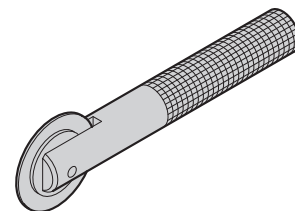

Subracks - *europac PRO* for railway applications

Coding peg for rear frame (NFF standard)

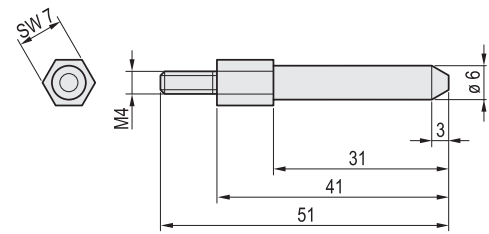

Order Information

Description	Qty/PU	Part no.
Coding peg, St, white zinc-plated	1	60895-018



For further information www.schroff.biz/oneclick
oneClick search code = Part no.

06104062

Rear hood for 3 U and 6 U subracks (for stainless steel EMC gasket)

Order Information

<p style="text-align: right;">bza45814</p>	<p>Rear hood</p> <p style="text-align: right;">bza45819</p> <p>Al, 1 mm, clear passivated; 60 mm additional side panel depth required (board depth + 60 mm); for shielding please order EMC gasket for horizontal rail separately; cannot be used simultaneously with rear corner profile</p>	<p>Stainless steel EMC gasket, between cover plate and horizontal rail</p> <p style="text-align: right;">06106052</p> <p>stainless steel EMC gasket, clips into the horizontal rail and forms the contact with the cover plate; suitable for all horizontal rails</p>																								
	<table border="1"> <thead> <tr> <th>Height</th> <th>Width</th> <th></th> <th></th> </tr> <tr> <th>U</th> <th>HP</th> <th>1 piece</th> <th>PU 10 pieces</th> </tr> </thead> <tbody> <tr> <td>3</td> <td>42</td> <td>34561-750</td> <td>24560-241</td> </tr> <tr> <td>3</td> <td>84</td> <td>34561-752</td> <td>24560-245</td> </tr> <tr> <td>6</td> <td>63</td> <td>34561-763</td> <td>24560-243</td> </tr> <tr> <td>6</td> <td>84</td> <td>34561-764</td> <td>24560-245</td> </tr> </tbody> </table>	Height	Width			U	HP	1 piece	PU 10 pieces	3	42	34561-750	24560-241	3	84	34561-752	24560-245	6	63	34561-763	24560-243	6	84	34561-764	24560-245	
Height	Width																									
U	HP	1 piece	PU 10 pieces																							
3	42	34561-750	24560-241																							
3	84	34561-752	24560-245																							
6	63	34561-763	24560-243																							
6	84	34561-764	24560-245																							
<p>Torx panhead screw, M4 x 6, St, zinc-plated, PU 100 pieces</p>	24560-135	–																								
<p>Assembly tool, For EMC gasket, stainless steel (horizontal rails), 1 piece</p>	–	24560-271																								

Note

- Other dimensions of rear hood available on request

Subracks – for railway applications ServicePLUS



configuration

Simple. Fast. For the product you want.

Components can be varied and combined freely

- Configuration tables from page 6.17
- Online configuration: www.schroff.co.uk/configuration



assembly

Assembled by professionals. Double benefit!

Fitting of all mechanical, electrical and electronic components by our specialists

- Professional and reliable from quantity 1
- Ready for despatch within 5 working days



modification

Small changes. Large impact.

Custom drillings, cut-outs and special colours for off-the-shelf products

- Custom modifications from quantity 1
- Ready for despatch within 10 working days



solution

Simple. Fast. From one source.

Integration and custom developments

- Special sizes (depth and width)
- Individual heat dissipation concepts
- Ready for despatch within 10 working days



express

When fast has to be faster.

Delivery time to customer's request

- Express logistics



academy

Knowledge. Sharing. Partnerships.

Knowledge transfer and partnership

- Seminars, CAD drawings, test reports, user reports

Subracks – for railway applications ServicePLUS

Application examples



Application: Subrack receptacle/mounting frame 06108006



Application: Automatic train control system 06108020



Application: Signalling control systems 41108002



Application: Mobile telephony system 41108001



Application: Control system Csee_DSCN2296



Application: Train control system 01004031

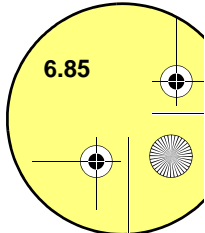

- Overview 0
- Cabinets 1
- Wall mounted cases 2
- Accessories for cabinets and wall mounted cases 3
- Climate control 4
- Desk-top cases 5
- Subracks/ 19" chassis ... 6**
- Front panels, plug-in units .. 7
- Systems 8
- Power supply units 9
- Backplanes .. 10
- Connectors, front panel component system 11
- Appendix 12

Subracks – for industrial applications

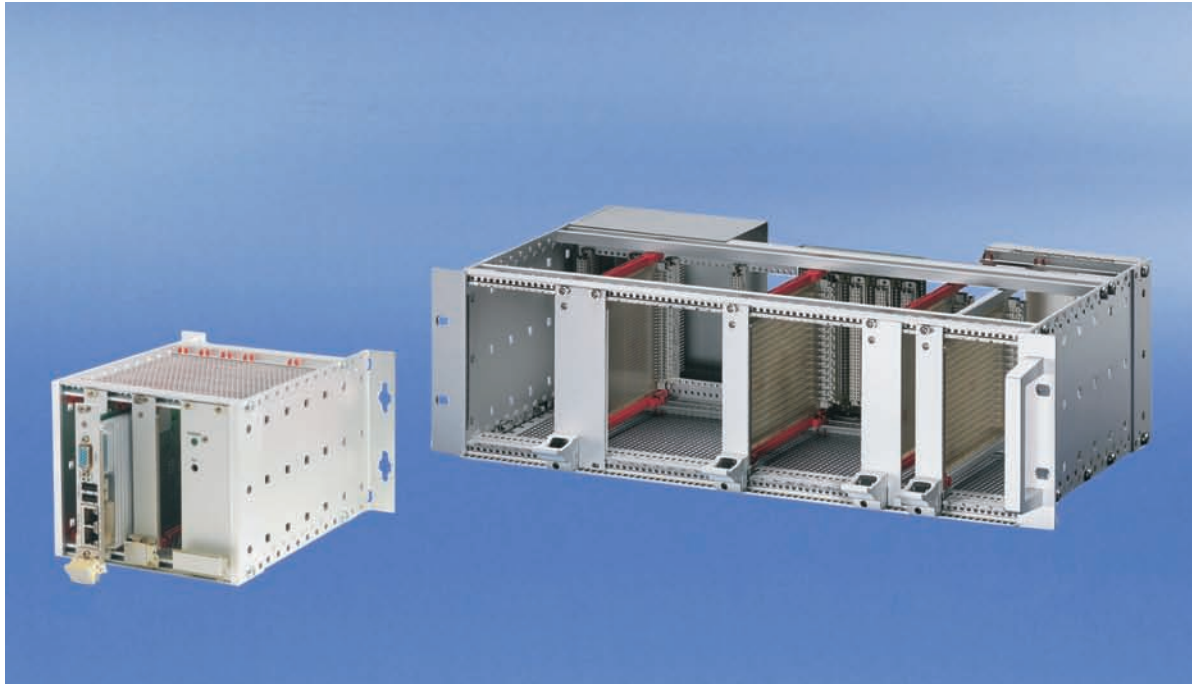

06112008

We package your euroboards - even for applications in harsh industrial environments

- A wide range in different dimensions, with finishes for the most diverse applications
- In accordance with the IEC 60297-3-101 and IEEE 1101.1 standards
- Tested to IEC 61587, VG 95373 T15, EN 50155, BN 411002, NF F 67-012, NF F 60-002
- Delivered as a kit in space-saving package or individually assembled and fitted to your specifications

Applications



06112009

Subracks for mounting on mounting plate incl. connection field



06112010

Subracks with special adaptation

Downloads and further important information can be found on the Internet under www.schroff.biz

Subracks – for industrial applications

Subrack for industrial applications

- Accommodates electronic boards in industrial applications
- Mounting frame for power distribution modules (connectors, RCD switches, ...)
- Bracket for panel mounting



06112002

Subrack for mounting on a mounting plate

- Height 3 U, width 28 HP, depth 205 mm
- For mounting on mounting plate
- For direct mounting of backplanes or to fit DIN plugs, DIN 41612/EN 60603-2



01494031

Module support

- Height 3 U, width 84 HP, depth 115 mm
- Power distribution modules to mount on lipped horizontal rail in accordance with DIN 43880

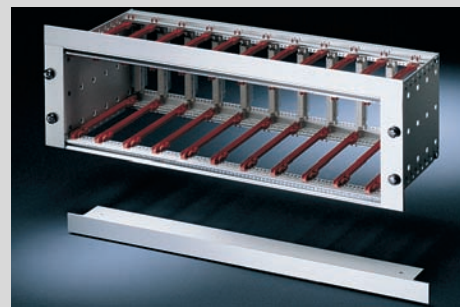

06197021

Bracket for mounting subracks in a panel

- Bracket widths 42 and 84 HP

Accessories

- Accessories (e.g. lipped rail adaptor, horizontal rails)

ServicePLUS from page 6.16 / 6.84

- e.g. modification (cut-outs)
- e.g. downloads (CAD drawings, user manuals, test reports)
- e.g. custom solutions (special depths, electromagnetically shielded applications)

www.schroff.biz/ServicePLUS



30407004

Overview 6.86

Introduction .. 6.4

Subrack for wall mounting . 6.88

Module support 6.89

Bracket for panel mounting 6.90

Accessories ... 6.91

ServicePLUS .. 6.16
Application examples 6.85

europacPRO 6.6
Subracks for mobile railway applications .. 6.70
europacPRO for rugged applications .. 6.92

Subracks - *europacPRO* for industrial applications

europacPRO subrack,
unshielded



- Subrack to mount on the wall or on mounting plate
- For mounting of euroboards to IEC 60297-3-101 in size 3 U, 160 mm deep
- Versions
 - For connector mounting (DIN 41612, EN 60602-3), with/without rear panel
 - For backplane mounting, with/without rear hood

NEW

Delivery comprises

Item	Qty	Description
1	2	Side panel, 3 U, Al, 2 mm with integrated wall-mounting bracket
2a	2	Front horizontal rail (L-KD)
2b	2	Rear horizontal rail (L-RC) for backplane mounting
2c	2	Rear horizontal rail (L-MZ) for connector mounting
3	2	Rear angle
4	2/4	Threaded insert, St, zinc-plated
5	2	Cover plate, pushed in
6	1	Rear hood, Al, 1 mm (only for version with rear hood)
7	1	Fixing materials kit, user manual

Order Information

Description	Height U	Width HP	Depth D mm	Depth D1 mm	Part no.
With rear panel, for connector mounting	3	28	205	175	24563-110
Without rear panel, for connector mounting	3	28	205	175	24563-109
With rear panel, for direct backplane fixing	3	28	205	175	24563-108
Without rear panel, for direct backplane fixing	3	28	205	175	24563-107

Accessories

Guide rails, accessories, 160 mm deep PBT, UL 94 V-0, red, groove width 2 mm, PU 10 pieces	24560-351
Front panels	Page 7.5
Front panel with handle	Page 7.16

Note

- EMC version on request

 For further information www.schroff.biz/oneclick
oneClick search code = Part no.

Illustration shows subrack without rear hood

06112001



06112050

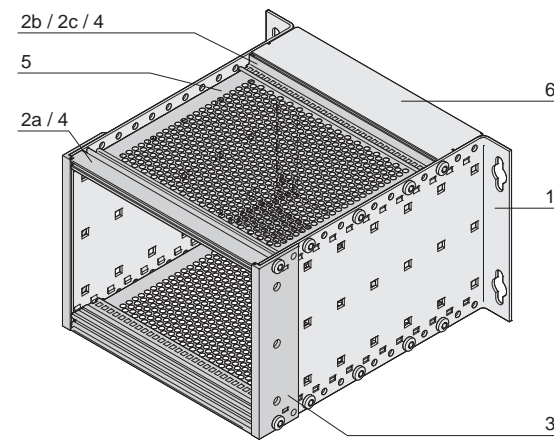
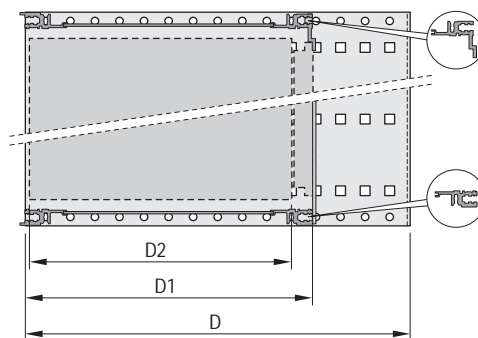

06112051

Connector/backplane mounting;
D=overall depth, D1=insertion depth,
D2=board depth = D1 - 15 mm

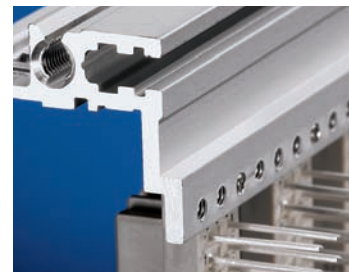

04400003

Horizontal rail to rear for connector mounting

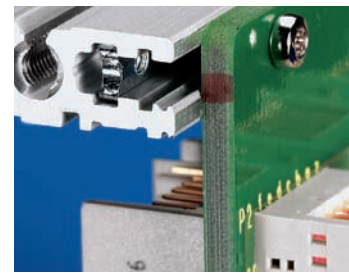

04400002

Horizontal rail to rear for direct backplane mounting

Subracks - *europac PRO* for industrial applications

19" module support, support rail to DIN 43880, hood

Order Information

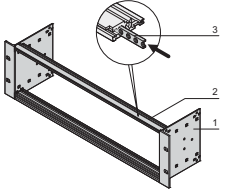
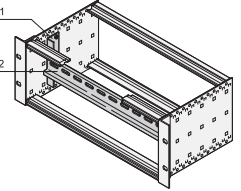
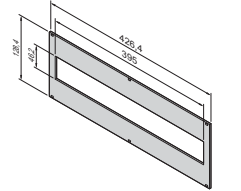
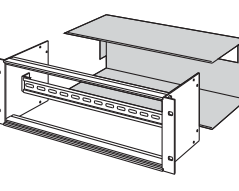
 <p>01494031</p>	<p>19" module support to accommodate power distribution modules</p>  <p>bls43467</p> <p>3 U, 84 HP, 115.5 mm deep; 2 side panels Al, 2 mm; 2 horizontal rails with short lip (L-KD), Al extrusion, surface anodised, contact surfaces conductive; 2 threaded inserts, St, zinc-plated; GND/earthing kit; fixing material kit;</p> <p>Please order support rail separately</p> <p>PU 1 kit</p> <p>24563-100</p>	<p>Support rails to DIN 43880</p>  <p>06105080</p> <p>2 adaptor brackets, Al, 2 mm; support rail, St, zinc-plated, (35/7.5 mm); for width 84 HP (430.5 mm);</p> <p>Mounted in module support or subrack on the side panel</p> <p>PU 1 kit</p> <p>24565-100</p>	<p>Front panel for 19" module support</p>  <p>06111053</p> <p>3 U, 84 HP, Al, 2.5 mm, front anodised, rear iridescent green chromated; GND/earth connection 6.3 mm FASTON; (cut-out 395 mm x 46.2 mm); two blanking plates, plastic, polyester, colour similar to RAL 7035; to cover unused module slots</p> <p>1 piece</p> <p>24563-096</p>	<p>Hood</p>  <p>BLA43492</p> <p>Al, 1 mm, with brush strip; is bolted to the rear of the module support; GND/earthing kit</p> <p>1 piece</p> <p>24564-100</p>

Accessories

- Power distribution modules see page 3.34

Subracks - *europac PRO* for industrial applications

Bracket for panel mounting

Order Information

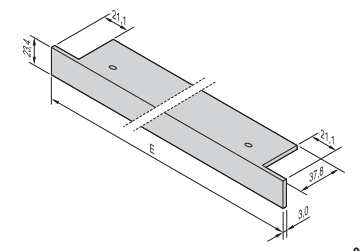
		Bracket (mounting angle)  <p>Al extrusion, anodised; serves as front visual cover of subrack at top and bottom when fitted into a panel; screwed in from the front with the horizontal rail; 2 brackets and 4 screws are required per subrack</p>
Usable width HP	Length mm	1 piece
42	269.2	34561-777
84	482.6	34561-779
Torx panhead screw 2.5 x 9.3, zinc-plated, PU 100 pieces		24560-141

Note

- Further widths available on request

Assembly cut-out

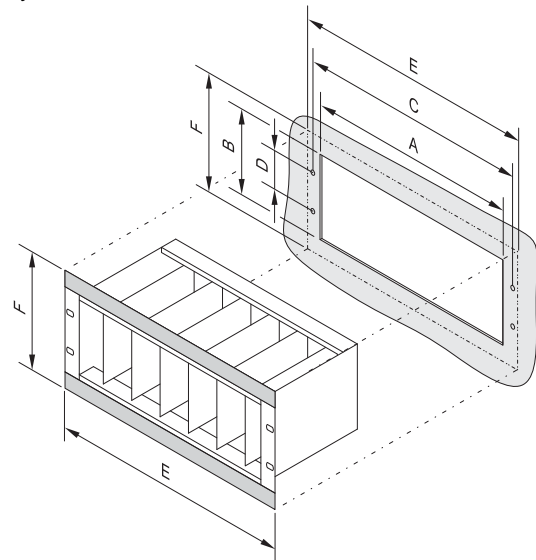

Dimensions table

U	HP	A mm	B mm	C mm	D mm	E mm	F mm
3	42	237.0	145.0	252.0	57.15	269.2	179.4
3	63	343.0	145.0	358.5	57.15	375.9	179.4
3	84	450.0	145.0	465.0	57.15	482.6	179.4
6	42	237.0	278.5	252.0	190.5	269.2	312.7
6	63	343.0	278.5	358.5	190.5	375.9	312.7
6	84	450.0	278.5	465.0	190.5	482.6	312.7

Subracks - **europac PRO** for industrial applications

Adaptor for horizontal rail mounting



- For mounting e.g. small subracks, small wall mounted cases, frame type plug-in units or PSUs on a horizontal rail with lip
- Adaptor is bolted to the desired product and can then be clipped to the lipped horizontal rail (DIN 43880)

Delivery comprises

Item	Qty	Description
1	1	Adaptor, Al extrusion, length 160 mm
1	1	Assembly kit

Order Information

Description	Part no.
Adaptor for horizontal rail mounting	11000-002

 For further information www.schroff.biz/oneclick
oneClick search code = Part no.



Example: Lipped horizontal rail adaptor for 19" PSU

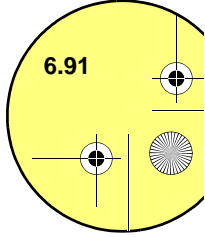

- Overview 0
- Cabinets 1
- Wall mounted cases 2
- Accessories for cabinets and wall mounted cases 3
- Climate control 4
- Desk-top cases 5
- Subracks/ 19" chassis ... 6**
- Front panels, plug-in units .. 7
- Systems 8
- Power supply units 9
- Backplanes .. 10
- Connectors, front panel component system 11
- Appendix 12

Subracks - *europac PRO* rugged

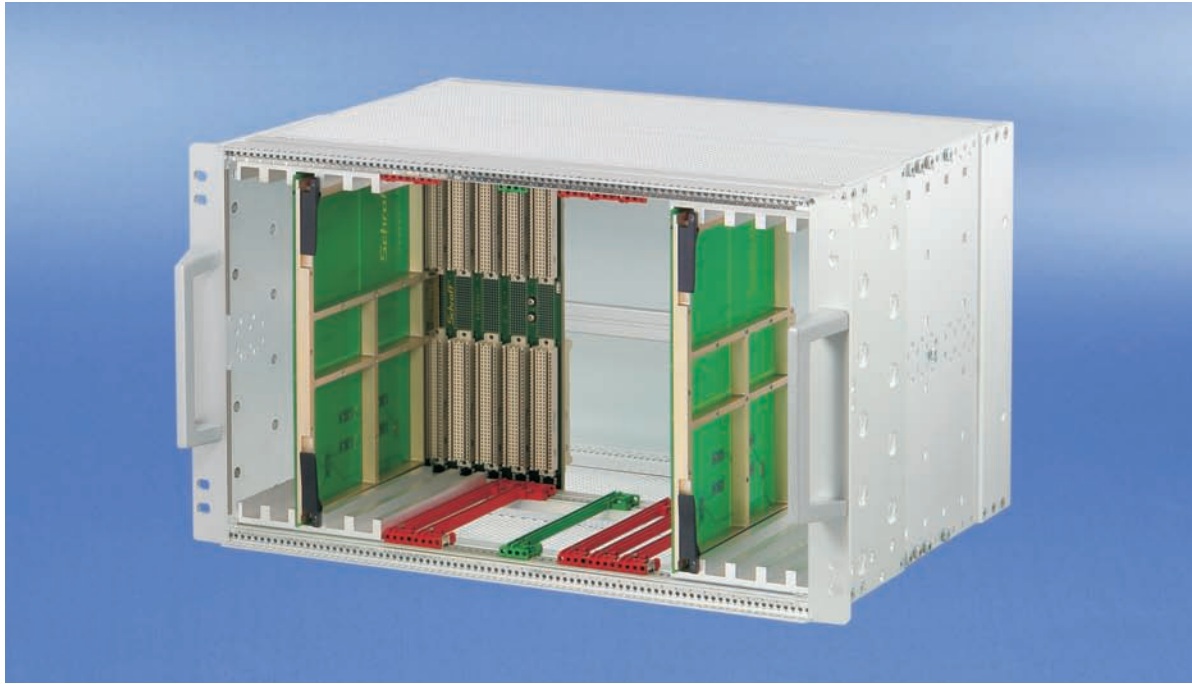

06112020



06112004
"rugged" horizontal rail with 3 hole fixing for increased stability (+60 % compared to 2 hole fixing of "heavy" horizontal rail)

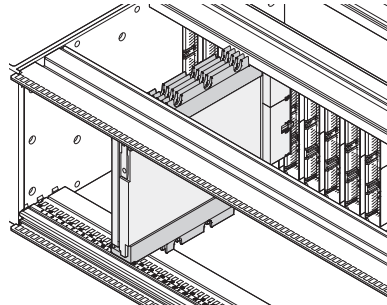

06112052
Special adaptor rails allow conducted cooled assemblies to be fitted



Y-axis_001a1
Shock and vibration resistant in all three axial directions

Standards/Approvals

- Internal and external dimensions in accordance with:
IEC 60297-3-100, -101, -102, -103, -104, -105, IEEE 1101.1, IEEE 1101.10/11
- Type of protection IP 20, in accordance with IEC 60529
- EMC testing to IEC 61587-3
- Shock and vibration test report:
MIL 167, IEC 61587 DL 3, MIL 810 G, MIL 901

Note

- Other finishes e.g. yellow chromated on request
- Subrack with telescopic slides can be adapted for cabinet mounting on request

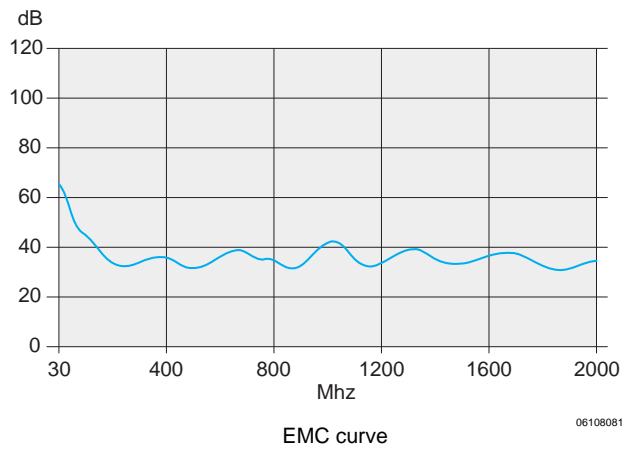

Downloads and further important information can be found on the Internet under www.schroff.biz

19" subracks

- Shock and vibration resistant up to 25 g
- Kits or individually configured subracks
- A product and accessory platform for the most different customers' requirements and applications
- Suitable for CompactPCI and VMEbus insertion and extractor handles
- EMC shielding can easily be retrofitted
- 3D PDF or CAD 3D data available for download



06112017

Kits

- All required parts are available under one part number, even partly assembled
- Most popular versions and dimensions available from stock
- For installed loads over 15 kg up to 60 kg
- Supplied as a space-saving flat pack

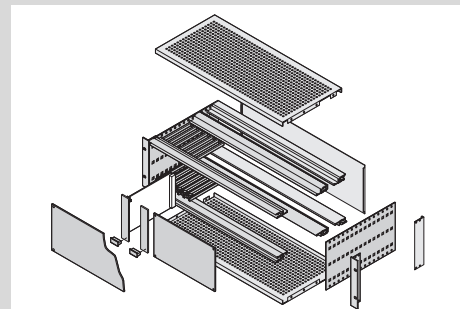

06105058

ServicePLUS individual configuration

- Single parts may individually be configured, respectively assembled on request (from quantity 1)
- Wide range of variants in height, width and depth
- Guide rails for different applications
- EMC shielding material to improve EMC performance
- Other accessories and assembly kits



30407004

ServicePLUS from page 6.95

- e.g. modification (cut-outs)
- e.g. downloads (CAD drawings, user manuals, test reports)
- e.g. custom solutions (special depths, electromagnetically shielded applications)

www.schroff.biz/ServicePLUS

Overview 6.92

Introduction ... 6.4

Kits 6.94

Individual configuration . . 6.97

ServicePLUS ... 6.95

Application examples 6.69

europacPRO ... 6.6

Subracks for mobile railway applications ... 6.70

europacPRO for industrial applications ... 6.86

Subracks - *europac* **PRO** rugged

Kit, rugged, shielded,
for backplane mounting



06112017

Illustration shows 3 U subrack

- Subrack with robust side panel and horizontal rail, type R "rugged"
- Rear horizontal rail for backplane mounting with insulation strip
- Shielding typically 40 dB at 1 GHz, 30 dB at 2 GHz (as per VG 95373, part 15), on condition that the front is closed with sealed front panels
- Shock and vibration resistant to 25 g

NEW

Delivery comprises (Kit)

Item	Qty	Description	
3 U		6 U	
1	2	2	Side panel type R, Al, 3 mm, clear passivated, with 19" support bracket 3.5 mm (tox-cold welded); for EMC gasketing (textile)
2	2	2	Front handle incl. fixing material kit
3	2	2	Rear corner profile for EMC gasketing (textile)
4	1	-	Front horizontal rail (R-KD)
4a	1	2	Front horizontal rail (R-LD)
4b	2	2	Rear horizontal rail (H-KD)
4c	2	2	Rear horizontal rail, centre (R-ST)
4d	-	1	Rear horizontal rail, centre (ST)
5	6	8	Threaded insert (pre-fitted)
6	2	2	Perforated strip (pre-fitted)
7	2	4	Insulation strip (pre-fitted)
8	2	2	EMC cover plate, rugged, with top cover locking
9	1	1	EMC rear panel
10	1	1	EMC gasketing material, fixing material kit, user manual

Order Information

Height	Width	Depth D	Depth D1	Part no.
U	HP	mm	mm	
3	84	295	175	24567-149
6	84	295	175	24567-449

Accessories

Guide rails, accessories, 160 mm deep	
PBT, UL 94 V-0, red, groove width 2 mm, PU 10 pieces	24560-351
Torx panhead screw 2.5 x 9.3, zinc-plated, PU 100 pieces; torque max. 0.2 Nm	24560-141
ESD clip for guide rails PU 50 pieces	24560-255
Guide rail accessories for heavy PCBs, extra strong	
Al extrusion, groove width 2 mm, 160 mm deep, 1 piece (SPQ 10)	34562-881
Torx pan head screw 2.5 x 7.3, zinc flake coating, black, 100 pieces; torque max. 0.2 Nm	24560-157
Adaptor to accommodate conduction cooled assemblies (CCA) for VPX applications, 160 mm deep, PU 1 pair; includes fixing material kit	24566-004
Adaptor to accommodate conduction cooled assemblies (CCA) for CompactPCI applications, 160 mm deep, PU 1 pair; includes fixing material kit	24566-005
19" dual fixing materials kit suitable for a subrack with double fixing holes (bolts, washers and nuts), PU 1 kit	24566-109

Note

- Test reports online
- For further accessories see from page 6.17

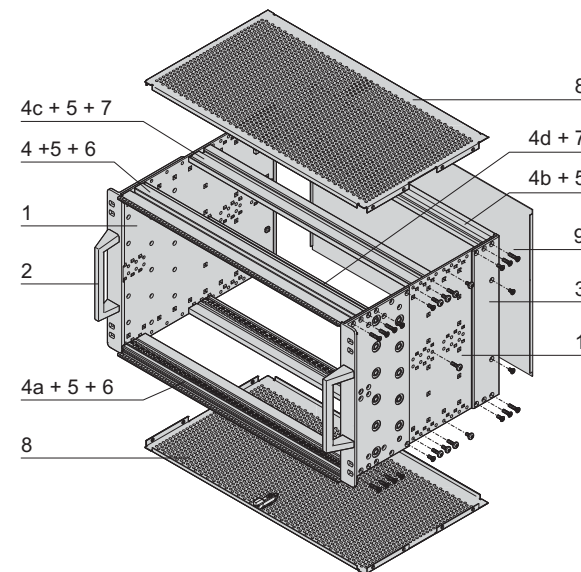

6 U

06112055

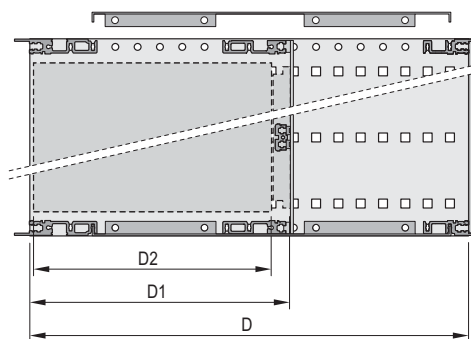

D = overall depth, D1 = insertion depth,
D2 = board depth = D1 - 15 mm

06112054



04400901

Rear horizontal rail for backplane mounting with insulation strip

Subracks - *europac PRO* rugged ServicePLUS



configuration

Simple. Fast. To the ideal product.

Components can be varied and combined freely

- Configuration tables from page 6.96
- Online configuration: www.schroff.co.uk/configuration



assembly

Assembled by professionals. Double benefit!

Fitting of all mechanical, electrical and electronic components by our specialists

- Professional and reliable from quantity 1
- Ready for despatch within 5 working days



modification

Small changes. Large impact.

Custom drillings, cut-outs and special colours for off-the-shelf products

- Custom modifications from quantity 1
- Ready for despatch within 10 working days



solution

Simple. Fast. From one source.

Integration and custom developments

- Special sizes (depth and width)
- Individual heat dissipation concepts
- Ready for dispatch within 10 working days



express

When fast has to be faster.

Delivery time to customer's request

- Express logistics



academy

Knowledge. Sharing. Partnerships.

Knowledge transfer and partnership

- Seminars, CAD drawings, test reports, user reports

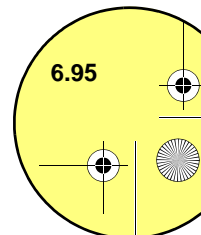

Subracks - *europac PRO* rugged ServicePLUS

Overview of individual components for shielded or unshielded subracks

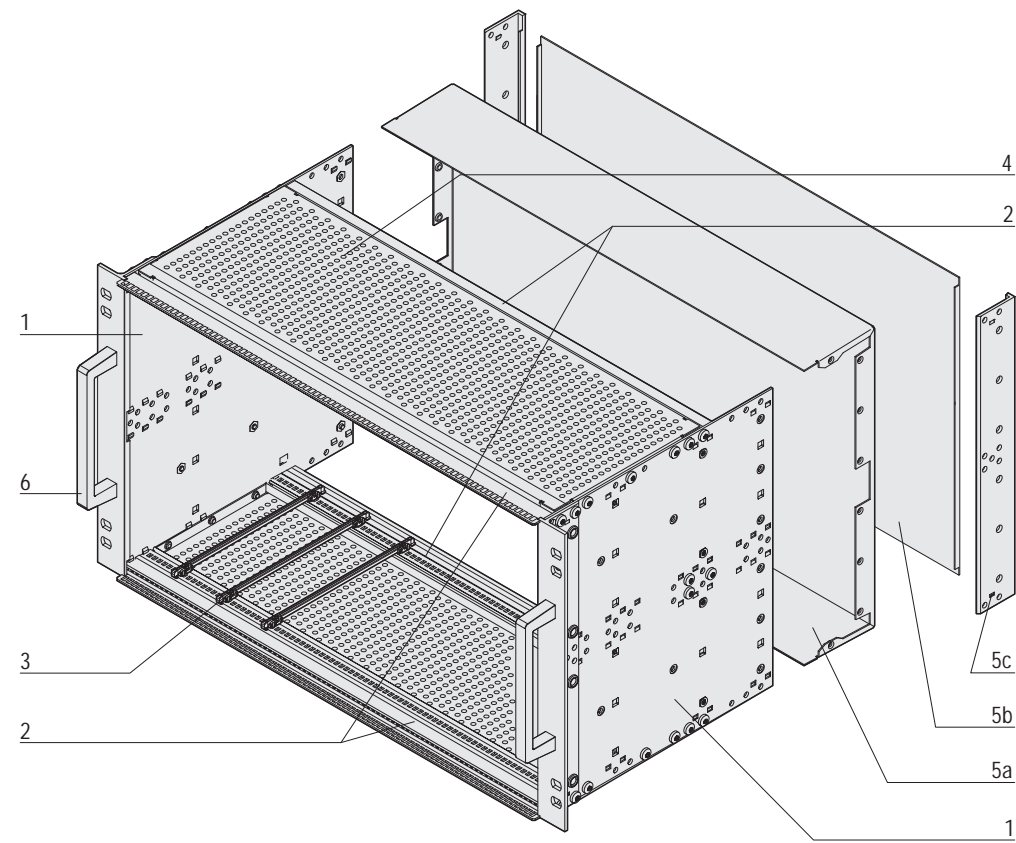

06108086

Item	Description	Description	page
Item 1	Side panels	Establish the height and depth of the subrack; Al, 3 mm, with universal hole positions for mounting of accessories	6.97
Item 2	Horizontal rails	Establish the width of the subrack; Al extrusion, with defined hole positions for guide rails, grooves for threaded inserts, M4 thread at front, functional rail shapes, basically differing with regard to their mechanical loading capacity: rugged loading up to 15 kg	6.98
Item 3	Guide rails	Guide rails act as interface between subracks and boards, for different board formats, are available in plastic or metal, optionally codable and optionally can be fitted with ESD clip to allow electrostatic discharge	6.105
Item 4	Cover plates	Provide mechanical protection and/or EMC shielding and are perforated	6.108
Item 5	Rear/front	Rear hood (5a) or front panel (5b) with corner profile (5c) as support for EMC shielding gaskets used in conjunction with shielded front panels; Note: rear hood and corner profile cannot be fitted simultaneously	6.47
Item 6	Handles	Handles can be mounted on the 19" brackets	6.97
-	EMC shielding (without illustration)	Extensive component range for specific shielding of subrack according to your application	6.110
-	Internal mounting (without illustration)	Universal assemblies, e.g. for horizontal and vertical mounting and for mounting plates	6.109 6.58

Subracks - *europac PRO* rugged ServicePLUS

Side panel type R, EMC sealing, corner profile, front handle

Order Information

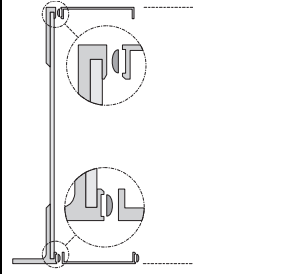
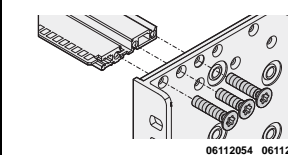
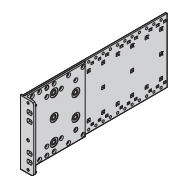
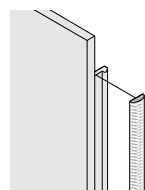
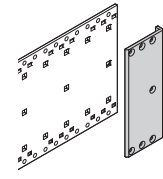
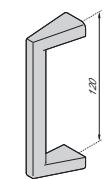
 		 Side panel type R for textile gasket <small>06112059</small>	 EMC textile gasket <small>04602054</small>	 Corner profile, rugged <small>06112058</small>	 Front handle <small>06112057</small>
	<p>Side panel, Al 3 mm, tox-cold welded with 19" Al bracket, 3.5 mm with handle hole, clear passivated, front anodised; please order front handles separately</p>	<p>Textile gasket, core: foam, sleeve: textile cladding with CuNi coating, UL 94 V-0, temperature range -40 ... 70 °C</p>	<p>Al extrusion, 3 mm, finish clear passivated; with lateral grooves for EMC stainless steel gasket; rear hood cannot be used simultaneously</p>	<p>Die-cast Al profile, powder-coated, RAL 9006; load-carrying capacity 30 kg, fixing material kit</p>	
Height U	Depth mm	PU 1 pair	PU 10 pieces	PU 1 pair	PU 1 kit
3	175	24568-145			
3	235	24568-147			
3	275	24568-143			
3	277.75	24568-144	21101-853	24566-199	24566-010
3	295	24568-149			
3	355	24568-151			
6	175	24568-445			
6	235	24568-447			
6	275	24568-443			
6	277.75	24568-444	21101-855	24566-499	24566-010
6	295	24568-449			
6	355	24568-451			

Fixing material kits see page 6.103

Side panel, type R

- For high mechanical demands up to 25 g (vibration resistance, shock and vibration requirements to e.g. IEC 61587-DL 3)
- 19" bracket is fixed firmly to side panel (tox-cold welded)
- Height 3 U and 6 U
- Depths 175, 235, 275, 277.75, 295 and 355 mm
- EMC shielding concept for front/rear with EMC textile gasket
- Other dimensions on request



For further information www.schroff.biz/oneclick
oneClick search code = Part no.

Subracks - *europac PRO* rugged ServicePLUS

Mounting position of horizontal rail/central rails

3 U (board depth 160, 220, 280 mm)

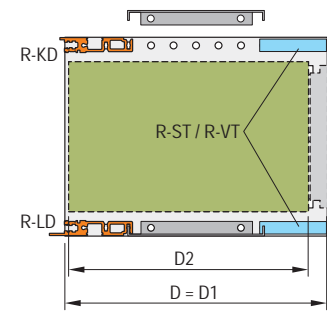

6 U (board depth 160, 220, 280 mm)

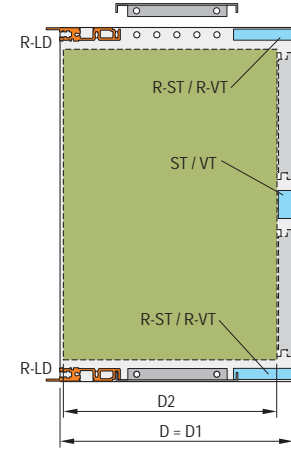

3 U (board depth 160, 220, 280 mm)

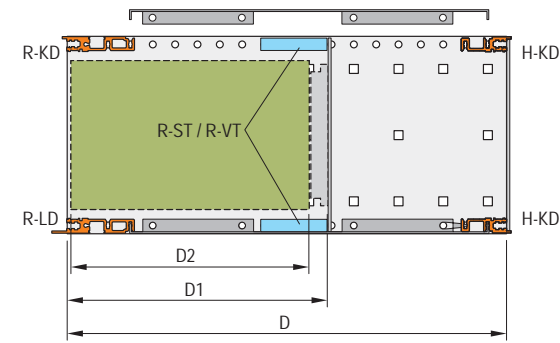

6 U (board depth 160, 220, 280 mm)

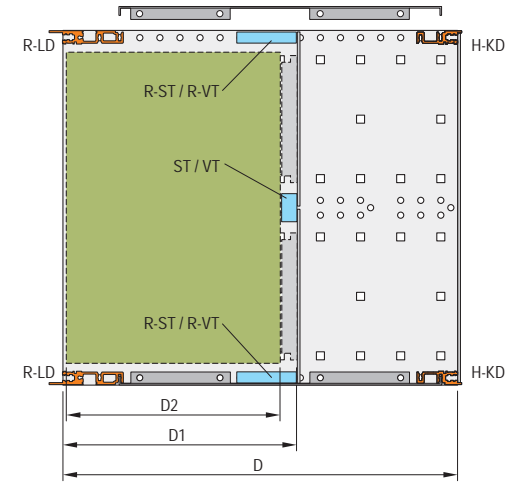

3 U (for CompactPCI/VME64x applications)

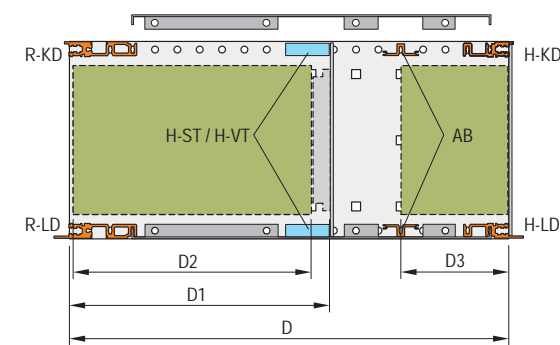

6 U (for CompactPCI/VME64x applications)

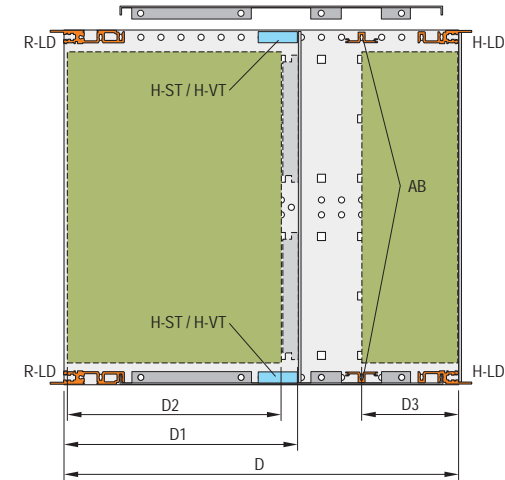

Horizontal rails

R-ST

R-VT

H-ST

H-VT

ST

VT



06112070

06112071

06112072

06112073

06112074

06112075





6.98 Main Catalogue
E 10/2012

Part number in bold face type: ready for despatch within 2 working days
Part number in normal type: ready for despatch within 10 working days

Subracks - *europac PRO* rugged ServicePLUS

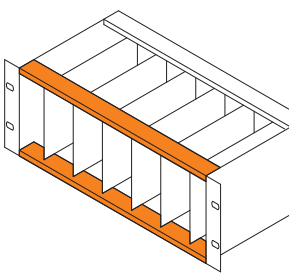
Front horizontal rails

Order Information

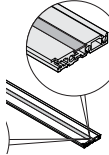
 <small>bza44980</small>		With long lip for insertion/ extraction of CompactPCI and VME64x boards "rugged" Type R-LD long lip  <small>06112004</small>	With long lip for insertion/ extraction of CompactPCI and VME64x boards "heavy" Type H-LD long lip  <small>06197008</small>	With short lip "rugged" Type R-KD short lip  <small>06112013</small>	With short lip "heavy" Type H-KD short lip  <small>06197008</small>
With HP markings from 28 HP, Al extrusion, anodised finish, conductive contact surface		Al extrusion, anodised finish, conductive contact surface, with HP markings	Al extrusion, anodised finish, conductive contact surface, with HP markings	Al extrusion, anodised finish, conductive contact surface, with HP markings	Al extrusion, anodised finish, conductive contact surface, with HP markings
Usable length	Length	1 piece (SPQ 10)¹⁾	1 piece (SPQ 10)¹⁾	1 piece (SPQ 10)¹⁾	1 piece (SPQ 10)¹⁾
HP	mm				
20	106.68	34566-320	34560-320	34566-220	34560-220
28	147.32	34566-328	34560-328	34566-228	34560-228
40	208.28	34566-340	34560-340	34566-240	34560-240
42	218.44	34566-342	34560-342	34566-242	34560-242
63	325.12	34566-363	34560-363	34566-263	34560-263
84	431.80	34566-384	34560-384	34566-284	34560-284
–	1000	34566-301	34560-301	34566-201	34560-201
Cover strips to cover the horizontal rail perforations Al, untreated, 0.8 mm, length 431.5 mm, 1 piece (SPQ 10) 		34566-184	–	34566-184	–
Threaded inserts see page		6.104	6.104	6.104	6.104
Fixing material kits see page		6.103	6.103	6.103	6.103

1) SPQ (standard pack quantity): Part number includes 1 piece, but delivery is exclusively made in standard pack quantity (SPQ); please order at least the SPQ quantity or a multiple
 "heavy" load > 7.5 kg; "rugged" load > 15 kg;

Note

- 1000 mm version without M4 thread to front, without printing and without notch for 19"-bracket
- EMC gasket see page 6.54
- For further horizontal rails see page 6.27

Rear horizontal rails

Order Information

Usable length HP		For indirect backplane fixing with insulation strip		For direct backplane fixing		For direct fixing of connectors in accordance with EN 60603-2 (DIN 41612)
		"rugged" Type R-ST Standard	"heavy" Type H-ST standard	"rugged" Type R-VT recessed installation	"heavy" Type H-VT recessed installation	"heavy" Type H-MZ with Z-rail
With HP markings from 28 HP, Al extrusion, anodised finish, conductive contact surface		Al extrusion, anodised finish, conductive contact surface, with HP markings		Al extrusion, anodised finish, conductive contact surface, with HP markings		Al extrusion, anodised finish, conductive contact surface, with HP markings
06105074		06112005	06197011	06112006	06197013	06197015
1 piece (SPQ 10) ¹⁾		1 piece (SPQ 10) ¹⁾		1 piece (SPQ 10) ¹⁾		1 piece (SPQ 10) ¹⁾
20	106.68	34566-520	34560-520	34566-720	34560-720	34560-920
28	147.32	34566-528	34560-528	34566-728	34560-728	34560-928
40	208.28	34566-540	34560-540	34566-740	34560-740	34560-940
42	218.44	34566-542	34560-542	34566-742	34560-742	34560-942
63	325.12	34566-563	34560-563	34566-763	34560-763	34560-963
84	431.80	34566-584	34560-584	34566-784	34560-784	34560-984
—	1000	34566-501	34560-501	34566-701	34560-701	—
Insulation strips see page		6.104	6.104	—	—	—
Threaded inserts see page		6.104	6.104	6.104	6.104	6.104
Fixing material kits see page		6.103	6.103	6.103	6.103	6.103

1) SPQ (standard pack quantity): Part number includes 1 piece, but delivery is exclusively made in standard pack quantity (SPQ); please order at least the SPQ quantity or a multiple
"heavy" load > 7.5 kg; "rugged" load > 15 kg;



Note

- 1000 mm version without M4 thread to front, without printing and without notch for 19"-bracket
- EMC gasket see page 6.54
- For further horizontal rails see page 6.27

Subracks - *europac PRO* rugged ServicePLUS

Rear horizontal rails, centre, for 6 U

Order Information

Usable length HP		Length mm	For indirect backplane fixing with insulation strip	For direct backplane fixing	For direct fixing of connectors in accordance with EN 60603-2 (DIN 41612)
			Type ST  Al extrusion, finish anodised, conductive contact surface; without markings	Type VT  Al extrusion, finish anodised, conductive contact surface; without markings	Type MZ  Al extrusion, finish anodised, conductive contact surface; without markings
			1 piece (SPQ 10) ¹⁾	1 piece (SPQ 10) ¹⁾	1 piece (SPQ 10) ¹⁾
20	106.68		34561-020	34561-120	34561-220
28	147.32		34561-028	34561-128	34561-228
40	208.28		34561-040	34561-140	34561-240
42	218.44		34561-042	34561-142	34561-242
63	325.12		34561-063	34561-163	34561-263
84	431.80		34561-084	34561-184	34561-284
-	1000		34561-001	34561-101	34561-201
Insulation strips see page			6.104	-	-
Threaded inserts see page			6.104	6.104	6.104
Fixing material kits see page			6.103	6.103	6.103

1) SPQ (standard pack quantity): Part number includes 1 piece, but delivery is exclusively made in standard pack quantity (SPQ); please order at least the SPQ quantity or a multiple
 "heavy" load > 7.5 kg; "rugged" load > 15 kg;

Note

- All horizontal rails without printed markings
- 1000 mm version without M4 thread to front

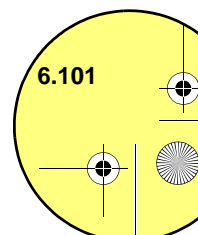

Subracks - *europac PRO* rugged ServicePLUS

Horizontal rails (type AB) for rear I/O applications

Order Information

		<p>For CompactPCI in rear I/O area</p> <p>Type AB</p> <p>Al extrusion, finish anodised, conductive contact surface; horizontal rail type AB (AB = support) is required to fix the guide rails for the 80 mm rear I/O boards; without markings</p>
Usable length HP	Length mm	1 piece (SPQ 10)¹⁾
20	106.68	34561-520
28	147.32	34561-528
40	208.28	34561-540
42	218.44	34561-542
63	325.12	34561-563
84	431.80	34561-584
–	1000	34561-501
Fixing material kits see page		6.103

1) SPQ (standard pack quantity): Part number includes 1 piece, but delivery is exclusively made in standard pack quantity (SPQ); please order at least the SPQ quantity or a multiple
heavy load > 7.5 kg; *rugged* load > 15 kg;

Note

- All horizontal rails without printed markings
- 1000 mm version without M4 thread in end

Subracks - *europac PRO* rugged ServicePLUS

Screws overview

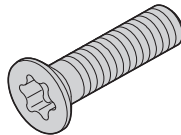
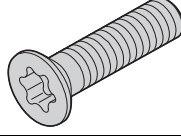
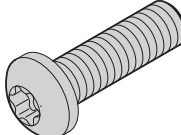
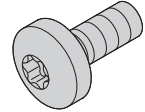
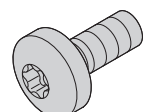
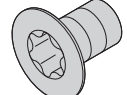
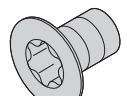
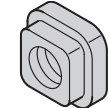
	Description	Material	Dimension	Qty/PU	Part no.
 <small>06712051</small>	Countersunk screw, with thread locking compound Application: Rugged side panel to horizontal rail; for area of tox-cold welded brackets and corner profiles <u>except</u> when guide rail is fitted to slot 1	Stainless steel	M4 x 18	100	24566-100
 <small>06712051</small>	Countersunk screw, with thread locking compound Application: Rugged side panel to horizontal rail; for area of tox-cold welded brackets and corner profiles <u>if</u> guide rail is fitted to slot 1	Stainless steel	M4 x 14	100	24566-101
 <small>82845940</small>	Panhead screw, with thread locking compound Application: Rugged side panel to horizontal rail; <u>not</u> for area of tox-cold welded brackets and corner profiles <u>except</u> when guide rail is fitted to slot 1	Stainless steel	M4 x 14	100	24566-102
 <small>06712053</small>	Panhead screw, with thread locking compound Application: Rugged side panel to horizontal rail; <u>not</u> for area of tox-cold welded brackets and corner profiles <u>if</u> guide rail is fitted to slot 1	Stainless steel	M4 x 10	100	24566-103
 <small>06712053</small>	Panhead screw, with thread locking compound Application: Rugged side panel to cover plate, <u>not</u> for area of tox-cold welded brackets and corner profiles	Stainless steel	M4 x 8	100	24566-104
 <small>06708053</small>	Torx countersunk screw, with thread locking compound Application: : Rugged side panel to cover plate, for area of tox-cold welded brackets and corner profiles	Stainless steel	M4 x 10	100	24566-106
 <small>06708053</small>	Torx countersunk screw, with thread locking compound Application: Rugged side panel to corner profile; in EMC-shielded subracks and to increase robustness	Stainless steel	M4 x 7	100	24566-105
 <small>AZA45921</small>	Square nut Application: Rugged side panel to corner profile; in EMC-shielded subracks and to increase robustness	Zinc-plated steel	M4	100	24560-140

Note

- Stainless steel screws; with organic surface layer (silver)



For further information www.schroff.biz/oneclick
oneClick search code = Part no.

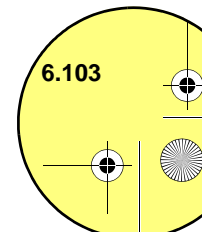

Subracks - *europac* **PRO** rugged

Threaded inserts, perforated strips, insulation strips

Order Information

Usable length HP	Threaded insert		Perforated strip		Insulation strip	
	Length mm	1 piece (SPQ 10) ¹⁾	Length mm	1 piece (SPQ 10) ¹⁾	Length mm	PU 10 pieces
20	106.18	34561-320	106.48	30845-189	101.50	24560-820
28	146.82	34561-328	147.12	30845-197	144.20	24560-828
40	207.78	34561-340	208.08	30845-209	205.12	24560-840
42	217.94	34561-342	218.24	30845-211	210.40	24560-842
63	324.62	34561-363	324.92	30845-232	316.88	24560-863
84	431.30	34561-384	431.60	30845-253	428.64	24560-884
196	1000.26	34565-196	1000.26	34565-396	-	-

Threaded insert

M2.5 M3

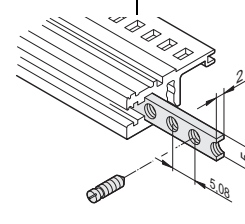

required for fixing the front panel to the horizontal rail;
St, zinc-plated; use collar screw 12.3 mm,
see page 6.64

Perforated strip

Item 1

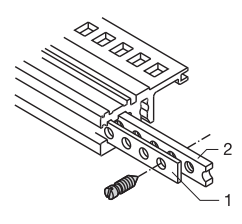

for centring shielded plug-in units, Al, 1 mm,
please order grub screw separately

Insulation strip

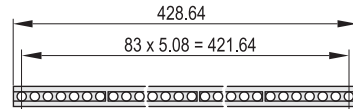

for insulated mounting of backplane;
PBT UL 94 V-0, grey

Accessories

Grub screw M2.5 x 8, PU 100 pieces	21100-276	-	-	-	-	-
Grub screw M2.5 x 9, PU 100 pieces	-	-	-	21101-359	-	-
Grub screw M3 x 8, PU 100 pieces	-	21100-646	-	-	-	-

1) SPQ (standard pack quantity): Part number includes 1 piece, but delivery is exclusively made in standard pack quantity (SPQ);
please order at least the SPQ quantity or a multiple

Part no. includes one packing unit (PU); delivery is exclusively made in PU

19" dual fixing materials kit

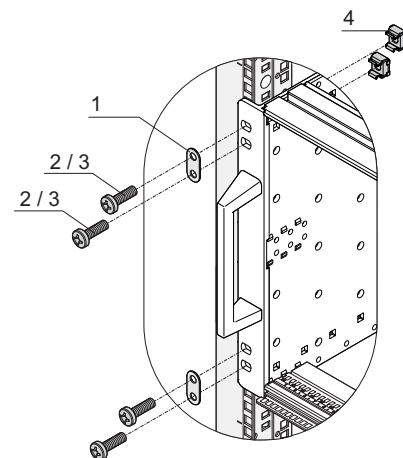

■ For fixing a subrack with dual fixing holes to 19" mounting
brackets (e.g. rugged and railroad subracks)

Delivery comprises

Item	Qty	Description
1	4	Double washer, stainless steel
2	8	M6 x 16 (Torx 30 drive)
3	8	M6 x 16 (Pozidrive)
4	8	Cage nut KM6
1	4	User manual

Order Information

Description	Part no.
19" dual fixing materials kit	24566-109

06113052

Subracks - *europac PRO* rugged ServicePLUS

Adaptor to accommodate conduction cooled assemblies (CCA)

Order Information

Adaptor to accommodate conduction cooled assemblies (CCA) in subracks		
		
<small>Al die-cast, silver, can be screw-fixed, 0.8" pitch; suitable for heavy and rugged horizontal rails, incl. fixing material kit</small>		
Board length	VPX	CompactPCI
mm	PU 1 pair	PU 1 pair
160	24566-004	24566-005

2) Part no. includes one packing unit (PU); delivery is exclusively made in PU

Guide rails for plug-in units and frame type plug-in units, one-piece, groove width 2 mm and 2.5 mm

Order Information

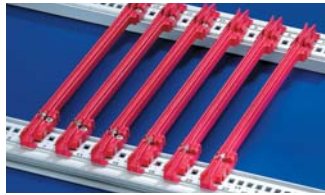
Assembly			For plug-in units and frame type plug-in units "Standard"	
<small>Plastic guide rail - can be clipped into Al extruded horizontal rails - can be clipped into 1.5 mm thick plates</small>				
<small>Storage temperature from -40 °C ... 130 °C</small>				
Board length	Groove width	Colour	<small>up to 220 mm length, PBT, UL 94 V-0; from 280 mm length, multi-piece, end piece PBT, UL 94 V-0, central section Al extrusion</small>	PBT, UL 94 V-0
mm	mm	mm	PU 10 pieces²⁾	1 piece (SPQ 50)¹⁾
70	2	red	–	34579-230
70	2	grey	–	34579-231
160	2	red	24560-351	64560-001
220	2	red	24560-353	64560-002
280	2	red	24560-379	–
340	2	red	24560-380	–
160	2.5	red	–	64560-096
220	2.5	red	–	64560-098

Accessories

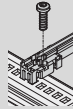
Retention screw, PU 100 pieces; Torque max. 0.2 Nm		24560-141	24560-141
ESD clip, PU 50 pieces		24560-255	24560-255

1) SPQ (standard pack quantity): Part number includes 1 piece, but delivery is exclusively made in standard pack quantity (SPQ); please order at least the SPQ quantity or a multiple



2) Part no. includes one packing unit (PU); delivery is exclusively made in PU

Description of accessories see from page 6.107

Subracks - *europac PRO* rugged ServicePLUS

Guide rails for heavy assemblies, CompactPCI, VME64x

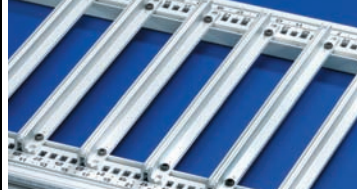
Order Information

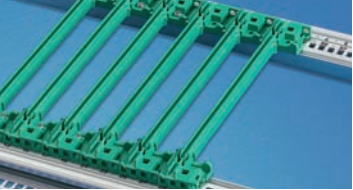
Assembly Plastic guide rails - can be clipped into Al extruded horizontal rails - can be clipped into 1.5 mm thick plates			For heavy modules, Al extrusion, silver, robust version	For CompactPCI, VME64x with coding In accordance with IEEE 1101.10 and IEC 60297-3-103	Offset 0.1" for power supply units in accordance with IEEE 1101.10 and IEC 60297-3-103
Storage temperature from -40 °C ... 130 °C			 Al extrusion; is screwed to horizontal rail "heavy" or "rugged" with retention screws	 One-piece for groove width 2 mm, PBT, UL 94 V-0; multi-piece for groove width 2.5 mm, end piece PBT, UL 94 V-0, middle section Al extrusion	 PBT, UL 94 V-0, for installation of power supplies in CompactPCI systems or plug-in units with SMD placement
Board length mm	Groove width mm	Colour mm	1 piece (SPQ 10) ¹⁾	PU 10 pieces ²⁾	PU 10 pieces ²⁾
70	2	red	–	24560-355	–
70	2	grey	–	24560-360	–
160	2	red	–	24560-356	–
160	2	grey	34562-881	24560-358	–
160	2	green	–	–	24560-359
220	2	grey	34562-882	–	–
220	2	green	34562-883	–	–
160	2.5	red	34562-884	–	–
220	2.5	red	34562-885	24561-330	–
220	2.5	grey	34564-881	24561-340	–
280	2.5	red	34564-882	24561-331	–
280	2.5	grey	34564-883	24561-341	–

Accessories

ESD clips, PU 50 pieces	–	24560-255	–
ESD clips, for alignment pin, PU 50 pieces	–	24560-256	24560-256
Retention screw, PU 100 pcs.; torque max. 0.2 Nm	24560-157	24560-141	24560-141
Coding peg, PU 100 pieces	–	20817-501	20817-501

1) SPQ (standard pack quantity): Part number includes 1 piece, but delivery is exclusively made in standard pack quantity (SPQ); please order at least the SPQ quantity or a multiple

Part no. includes one packing unit (PU); delivery is exclusively made in PU

Description of accessories see from page 6.107

Subracks - *europac PRO* rugged ServicePLUS

Guide rail accessories

Order Information

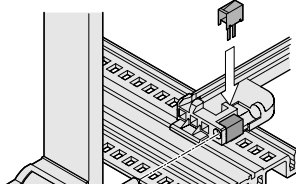
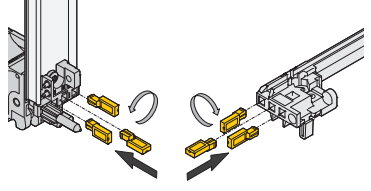
	<p>ESD clips, CompactPCI/VME 64 alignment pin for guide rails</p>  <p>06103052</p> <p>Spring steel, tin-plated, ESD clip, for alignment pin in accordance with IEEE; can be plugged into the guide rails with coding and into the keying/coding block; provides conductive contact between the guide pin of the inserter/ extractor handle (IEL or IET handle) and the horizontal rail</p>	<p>Coding for plug-in components</p> <p>Keying/coding for CompactPCI, VME64x handles to IEEE 1011.10 and IEC 60297-3-103</p>  <p>04612052</p> <p>Keying/coding peg, PBTP, UL 94 V-0, RAL 7035: The keying/coding pegs prevent plug-in units to be mounted in wrong slots. They are inserted in the chambers of the codable card guides as well as in the insertion/extraction handles IEL or IET (4 possible positions), resulting in 64 codings per card guide; when coding the upper and lower card guide, 4096 codings will result;</p>
Assembly	PU 50 pieces ²⁾	PU 100 pieces ²⁾
At the top/ at the bottom	24560-256	20817-501

²⁾ Part no. includes one packing unit (PU); delivery is exclusively made in PU

Guide rail accessories

Order Information

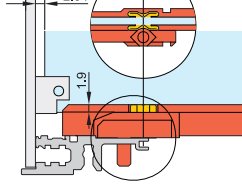
	<p>ESD clip for guide rails</p>  <p>04503050</p> <p>Spring steel, tin-plated, ensures conductive contact between board and horizontal rail, on both the solder side and the component side</p>
Colour	silver
Assembly	PU 50 pieces
above/below	24560-255

Subracks - *europac PRO* rugged ServicePLUS

Cover plates for bolting to rugged side panel

Order Information

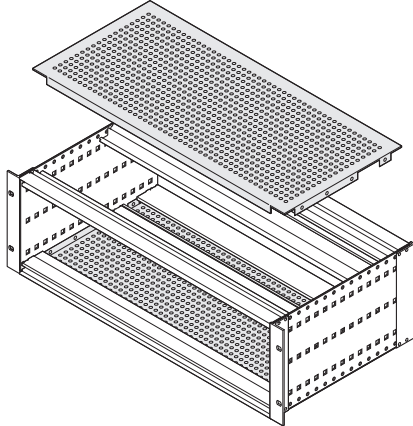
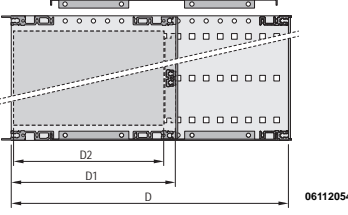
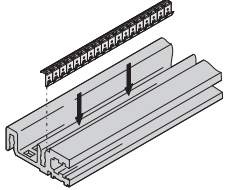
		<p>Cover plate for bolting to side panel</p>  <p>Perforated Al plate, 1.2 mm, hole diameter 4.0 mm, passivated, perforation ratio 58 %, incl. retention screws;</p> <p>4 stainless steel EMC contact strips per subrack are required for shielding, please order separately</p>		<p>Stainless steel EMC gasket, between cover plate and horizontal rail</p>  <p>Stainless steel EMC gasket, clips into the horizontal rail and forms the contact with the cover plate; suitable for all horizontal rails</p>	
Width HP	Depth D mm	Application	PU 1 pair	PU 10 pieces	PU 100 pieces
84	175	160 mm board depth (D2)	24568-004	24560-245	24560-246
84	235	220 mm board depth (D2)	24568-008		
84	295	280 mm board depth (D2)	24568-012		
84	275	160 mm board depth (D2) CompactPCI, 80 mm rear I/O	24568-032		
84	277.75	160 mm board depth (D2) CompactPCI, 80 mm rear I/O	24568-036		
84	295	160 mm board depth (D2), approx. 120 mm clearance behind backplane	24568-016		
84	355	220 mm board depth (D2), approx. 120 mm clearance behind backplane	24568-020		

Accessories

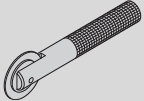
Cover plate latch, additional securing for rugged cover plate, PU 4 pieces		24566-007	-	-
Assembly tool, to fit EMC gasket, stainless steel, for horizontal rails, 1 piece		-	24560-271	24560-271

Note

- Cover plates without perforation available on request
- Mounting position of horizontal rails, see page 6.98

 For further information www.schroff.biz/oneclick
oneClick search code = Part no.

Subracks - *europac PRO* rugged ServicePLUS

Combined mounting (6 U and 2 x 3 U one above the other)

Order Information

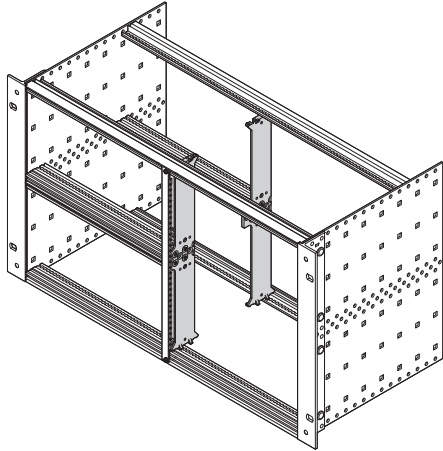
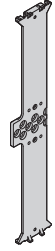
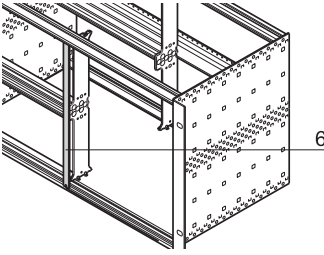
 <p>06112076</p>	<p>Rugged struts for combined mounting</p>  <p>06112077</p> <p>6 U, die-cast zinc; fixing material kit</p>	<p>Front panel for textile EMC gasket, 6 U, 2 HP Item 6</p>  <p>6</p> <p>bpa46550</p> <p>Al, 2.5 mm, U-profile with notch, 6 U, 2 HP</p>
<p>Height U</p>	<p>PU 2 pieces</p>	<p>1 piece (SPQ 5)¹⁾</p>
<p>6</p>	<p>24566-400</p>	<p>30849-140</p>

Accessories

<p>Pozidrive/slotted collar screw M2.5 x 12.3, St, nickel-plated, PU 100 pieces</p>	<p>—</p>	<p>21101-101</p>
<p>Pozidrive/slotted collar screw M2.5, black, zinc-plated, PU 100 pieces</p>	<p>—</p>	<p>21101-102</p>
<p>Washer 2.7 x 5 x 1, PA 6, PU 100 pieces</p>	<p>—</p>	<p>21101-121</p>
<p>Textile gasket, core: foam, sleeve: textile cladding with CuNi coating, UL 94 V-0, PU 10 pieces</p>	<p>—</p>	<p>21101-855</p>

Note

- Rugged horizontal rails in various lengths, see page 6.99

Subracks - *europac PRO* rugged ServicePLUS

EMC gaskets between front/rear panel and horizontal rail

Order Information

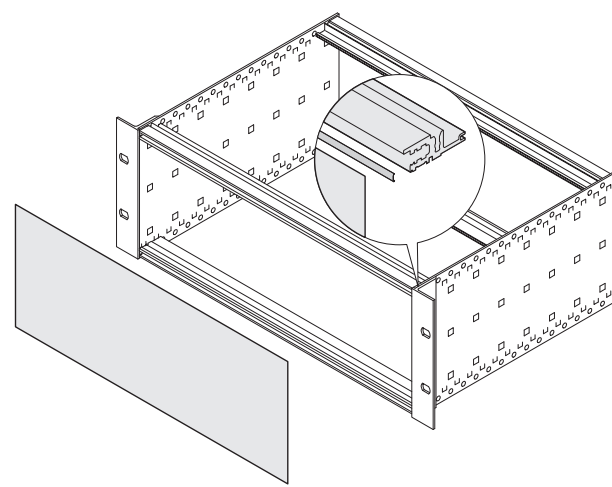

06102053

Stainless steel EMC gasket
between front panel/rear panel and horizontal rail

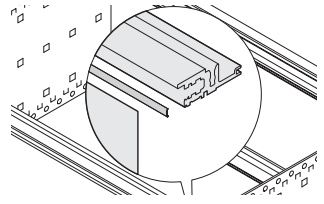

06102053

stainless steel; for front and rear horizontal rails (type VT)

	Width HP	Depth mm	PU 10 pieces	PU 100 pieces
	28	131.8	24560-229	—
	42	202.9	24560-231	—
	63	304.5	24560-233	—
	84	416.6	24560-235	24560-236

EMC gaskets between front panel and 19" bracket/corner profile

Order Information

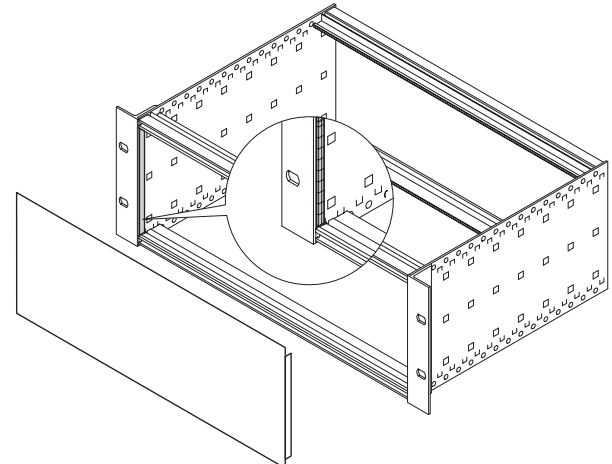

06105077

Textile EMC gasket
between front panel/rear panel and 19" bracket/corner profile

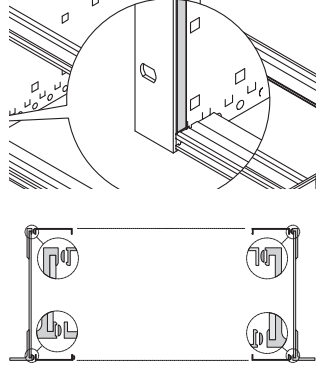

06102056

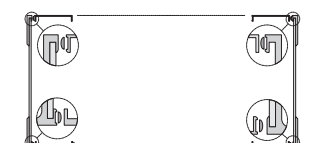

06100054

textile gasket,
core: foam,
sleeve: textile cladding with CuNi coating,
UL 94 V-0C

	Height U	Depth mm	PU 10 pieces	PU 100 pieces
	3	97.5	21101-853	21101-854
	6	232.5	21101-855	21101-856

Subracks - *europacPRO* rugged ServicePLUS

EMC gasket between horizontal rail and cover plate

Order Information

		Stainless steel EMC gasket, between cover plate and horizontal rail <p>stainless steel EMC gasket, clips into the horizontal rail and forms the contact with the cover plate; suitable for all horizontal rails</p>	
Width HP	Depth mm	PU 10 pieces	PU 100 pieces
42	202.9	24560-241	—
84	416.6	24560-245	24560-246
Assembly tool, to fit EMC gasket, stainless steel, for horizontal rails, 1 piece 		24560-271	24560-271

EMC gasket between backplane and side panel

Order Information

		Stainless steel EMC gasket between backplane and side panel (depth-offset installation) <p>2 x support profile, Al extrusion, 2 x stainless steel EMC gasket; for vertical EMC shielding between depth-offset shielded backplane and side panel: dimensions for 84 HP A = 425.8 mm, B < 429.9 mm, C = 429.8 mm, D = 431.8 mm</p>	
Height U	Depth mm	PU 1 kit	
3	97.5	24561-199	
6	187.5	24561-499	
Torx countersunk screw M4 x 7, St, zinc-plated, PU 100 pieces		24566-105	
Square nut M4, St, zinc-plated, PU 100 piece		24560-140	

With appropriate design, the backplane can be used as shielded rear wall of the rack; in this case a rear horizontal rail (L-type VT or H-VT) must be used for deeper installation to ensure the horizontal contact.

Für den vertikalen Kontakt kann die Trägerleiste standardmäßig an der europacPRO-Seitenwand befestigt werden (Tiefenraster 30 mm)

Overview 0

Cabinets 1

Wall mounted cases 2

Accessories for cabinets and wall mounted cases 3

Climate control 4

Desk-top cases 5

**Subracks/
19" chassis ... 6**

Front panels, plug-in units .. 7

Systems 8

Power supply units 9

Backplanes .. 10

Connectors, front panel component system 11

Appendix 12

19" chassis - *multipacPRO*



06005001

Standards/certifications

- Exterior dimensions in accordance with: IEC 60297-3-100, 101, 105
- Ingress protection IP 20 in accordance with IEC 60529
- EMC testing in accordance with VG 95373 part 15 or IEC 61587



06008009

Handles can be bolted on from front



06008010

High stability with aluminium profile side panel

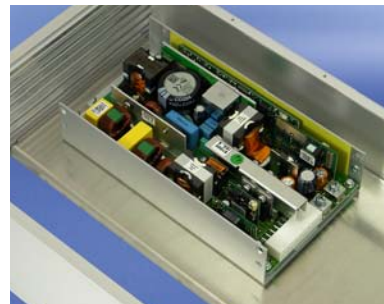

06008011

Mounting plate for fitting heavy components

Top cover and base plate in 3 versions



06008003

Plain



06008005

Perforated



06008004

For standardised board mounting



Downloads and further important information can be found on the Internet under www.schroff.biz

Main Catalogue
E 10/2012

The ideal solution for electronic devices in the most compact dimensions

- Aluminium or steel (AlZn coated) designs
- For standardised 19" board mounting or for installation of non-standardised components
- EMC shielding upgradable
- Mounting service and customized machining with ServicePLUS



06008005

19" complete chassis

- 2 materials
 - Steel plate (AlZn coated)
 - Aluminium
- 3 top cover versions
 - Top cover/base plate, solid
 - Top cover/base plate, perforated (aluminium version)
 - Top cover/base plate for standardised PCBs (aluminium version)



06008001

19" chassis, individually configured from separate parts

- For non-standardised assemblies with mounting plate
- For standardised board assembly
- Customised solutions



30407004

ServicePLUS from page 6.118

- e.g. individual configuration and assembly
- e.g. modification (cut-outs)
- e.g. downloads (CAD drawings, user manuals, test reports)
- e.g. custom solutions (special sizes)

www.schroff.biz/ServicePLUS

FRONT PANEL EXPRESS

19" complete chassis (St) 6.114
 19" complete chassis (Al) 6.115

19" chassis for non-standardised assembly 6.120
 19" chassis for standardised assembly 6.122

Accessories
 Guide rails 6.124
 Telescopic slides
 1 U 6.125
 Telescopic slides
 2 U 6.126

ServicePLUS . . 6.118

Application examples 6.127

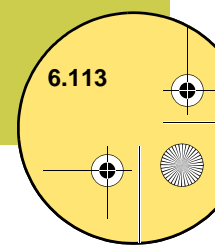

19" chassis - *multipacPRO*

19" complete chassis from steel with plain top cover and base plate

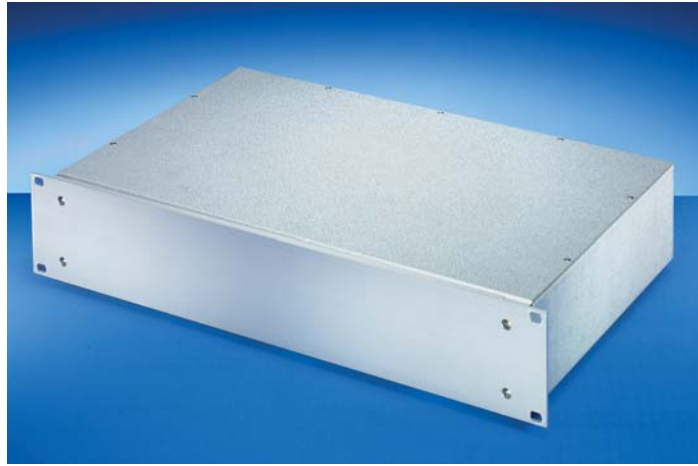

- Complete chassis, St (AlZn coated) with Al extrusion front panel
- Detachable rear panel for easy machining
- EMC shielding of approx. 30 dB(A) at 1 GHz (without additional shielding material)
- In accordance with standard IEC 60297-3-101
- In the 1 U version 19" and ATX power supplies can be assembled up to a clearance of 40 mm

Delivery comprises (Kit)

Item	Qty	Description
1	1	Front panel, Al extrusion, 3 mm; in 1 U: front anodised, rear etched; from 2 U: front and rear side of front panels clear passivated
2	1	Base body, plain, St, 1 mm, (AlZn coated)
3	1	Rear panel, St, 1 mm (AlZn coated)
4	1	Cover, plain, St, 1 mm (AlZn coated)
5	1	Assembly kit

Order Information

Height U	Height H mm	Depth T mm	Part no.
1	43.7	220	20860-120
1	43.7	280	20860-121
1	43.7	340	20860-122
2	88.1	280	20860-126
2	88.1	340	20860-127

Accessories

Front handles incl. assembly kit for 1 U, Al extrusion, anodised, PU 2 pieces	20860-256
Front handles incl. assembly kit for 2 U, Al extrusion, anodised, PU 2 pieces	20860-257
EMC sealing to close the gap at the front between case and front panel, 2 saw tooth gaskets, stainless steel, PU 1 piece	20860-132

Note

- Further versions with steel front panel (pizza box) available on request
- Telescopic slides cannot be used
- No special EMC version available
- Standardised internal mounting kits cannot be used

 For further information www.schroff.biz/oneclick
oneClick search code = Part no.

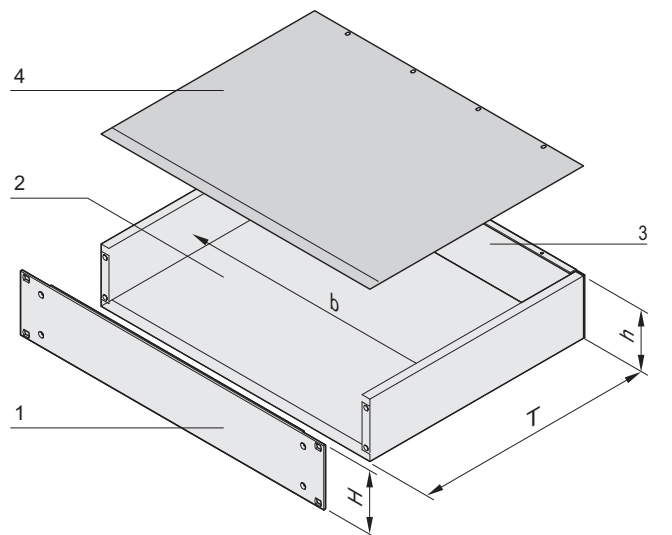

h = clear height (overall) (H - 3.0 mm)
b = clear installation width = 447 mm

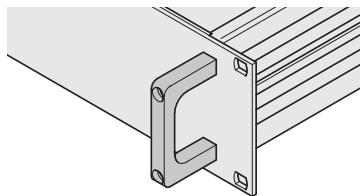

Front handle



ServicePLUS see page 6.118

19" chassis - *multipacPRO*

19" complete chassis from aluminium with plain top cover and base plate



- Complete chassis from aluminium
- Detachable rear panel for easy machining
- EMC shielding of approx. 30 dB(A) at 1 GHz (without additional shielding material)
- In accordance with standard IEC 60297-3-100, -101, -105
- In the 1 U version 19" and ATX power supplies can be assembled up to a clearance of 35 mm

Delivery comprises (Kit)

Item	Qty	Description
1	1	Front panel, Al extrusion, 3 mm; in 1 U: front anodised, rear etched; from 2 U: front and rear side of front panels clear passivated
2	1	Rear panel, Al, 2 mm, etched
3	1	Base plate, plain, Al, 1 mm
4	1	Cover plate, plain, Al, 1 mm
5	2	Side panel, Al extrusion, raw; with grooves for threaded insert (2 x 7); 5 U, two-piece, 3+2 U
6	1	Assembly kit

Order Information

Height U	Height H mm	Depth T mm	Part no. Kit
1	43.7	220	20860-601
1	43.7	280	20860-602
2	88.1	280	20860-605
2	88.1	340	20860-606
3	132.6	280	20860-607
3	132.6	340	20860-608
3	132.6	400	20860-609
4	177.0	340	20860-612
4	177.0	400	20860-613
4	177.0	460	20860-614
5	221.5	460	20860-615

EMC gasketing kit Silicone/nickel gasket 2100 mm for contacting side panel/cover plate; seal, stainless steel, for front panel/cover plate, 1 kit 20860-130

Front handles incl. assembly kit for 1 U, Al extrusion, anodised, PU 2 pieces 20860-256

Front handles incl. assembly kit for 2 U, Al extrusion, anodised, PU 2 pieces 20860-257

Front handles incl. assembly kit for 3 U, Al extrusion, anodised, PU 2 pieces 20860-258

Front handles incl. assembly kit for 4 U, Al extrusion, anodised, PU 2 pieces 20860-259

Front handles incl. assembly kit for 5 U, Al extrusion, anodised, PU 2 pieces 20860-260

Note

- Threaded inserts to push into the side panel see page 6.121
- Telescopic slides to mount into cabinet see page 6.125

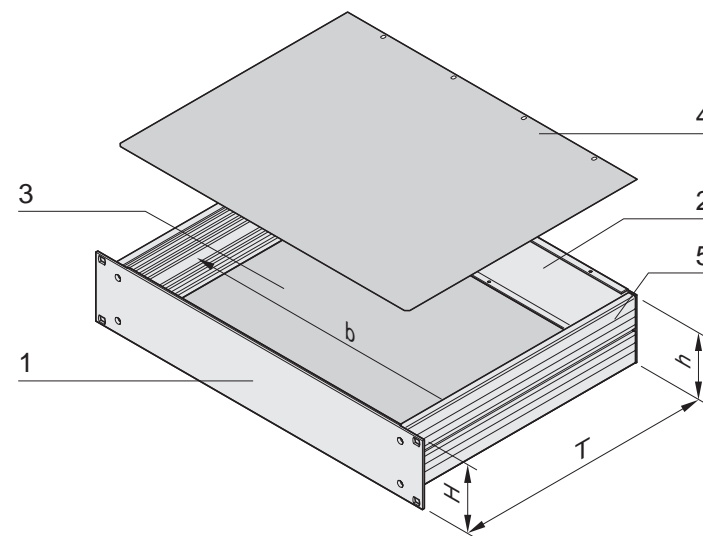

h = clear height (overall) (H - 8.1 mm)
b = clear installation width = 403 mm

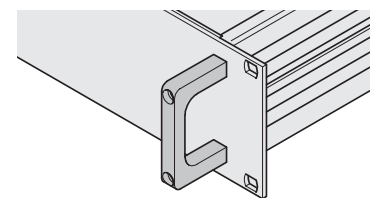

Front handle



ServicePLUS see page 6.118

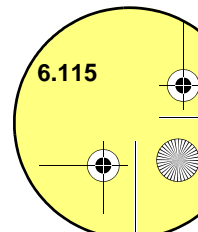

19" chassis - *multipacPRO*

19" complete chassis from aluminium with perforated top cover and base plate



- Complete chassis from aluminium
- Detachable rear panel for easy machining
- In the 1 U version 19" and ATX power supplies can be assembled up to a clearance of 35 mm
- EMC shielding of approx. 30 dB(A) at 1 GHz (without additional shielding material)
- In accordance with standard IEC 60297-3-100, -101, -105

Delivery comprises (kit)

Item	Qty	Description
1	1	Front panel, Al extrusion, 3 mm; in 1 U: front anodised, rear etched; from 2 U: front and rear side of front panels clear passivated
2	1	Rear panel, Al, 2 mm, etched
3	1	Base plate, perforated, Al, 1 mm
4	1	Cover plate, perforated, Al, 1 mm
5	2	Side panel, Al extrusion, raw; with grooves for threaded insert (2 x 7); 5 U, two-piece, 3+2 U
6	1	Assembly kit

Order Information

Height U	Height H mm	Depth T mm	Part no.
1	43.7	220	20860-621
1	43.7	280	20860-622
2	88.1	280	20860-625
2	88.1	340	20860-626
3	132.6	280	20860-627
3	132.6	340	20860-628
3	132.6	400	20860-629
4	177.0	340	20860-632
4	177.0	400	20860-633
4	177.0	460	20860-634
5	221.5	460	20860-635

EMC gasketing kit Silicone/nickel gasket 2100 mm for contacting side panel/cover plate; seal, stainless steel, for front panel/cover plate, 1 kit 20860-130

Front handles incl. assembly kit for 1 U, Al extrusion, anodised, PU 2 pieces 20860-256

Front handles incl. assembly kit for 2 U, Al extrusion, anodised, PU 2 pieces 20860-257

Front handles incl. assembly kit for 3 U, Al extrusion, anodised, PU 2 pieces 20860-258

Front handles incl. assembly kit for 4 U, Al extrusion, anodised, PU 2 pieces 20860-259

Front handles incl. assembly kit for 5 U, Al extrusion, anodised, PU 2 pieces 20860-260

Note

- Threaded inserts to push into the side panel see page 6.121
- Telescopic slides to mount into cabinet see page 6.125

 For further information www.schroff.biz/oneclick
oneClick search code = Part no.

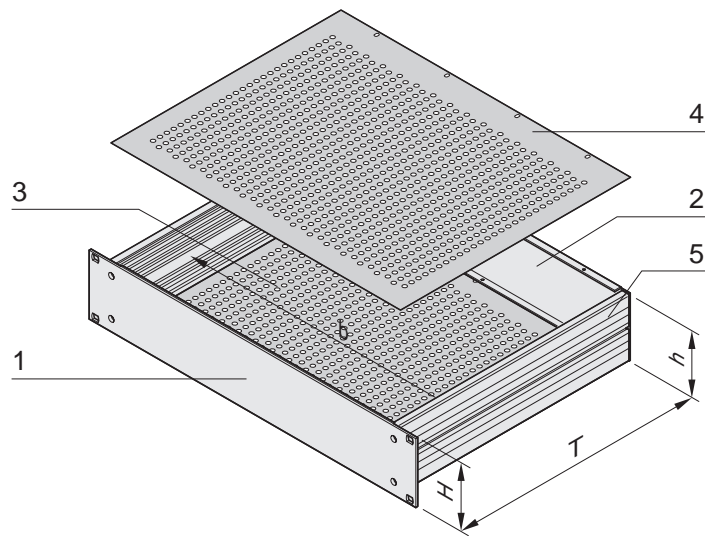

h = clear height (overall) (H - 8.1 mm)
b = clear installation width = 403 mm

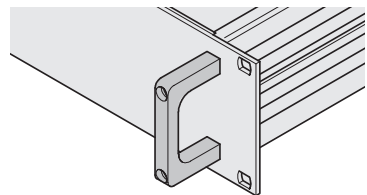

Front handle



ServicePLUS see page 6.118

19" chassis - *multipacPRO*

19" complete chassis from aluminium,
for assembly of euroboards



- Complete chassis from aluminium
- Detachable rear panel for easy machining
- EMC shielding of approx. 30 dB(A) at 1 GHz (without additional shielding material)
- In accordance with standard IEC 60297-3-100, -101, -105
- In the 1 U version 19" and ATX power supplies can be assembled up to a clearance of 35 mm

Delivery comprises (Kit)

Item	Qty	Description
1	1	Front panel Al extrusion, 3 mm; in 1 U: front anodised, rear etched; from 2 U: front and rear side of front panels clear passivated
2	1	Rear panel, Al, 2 mm, etched
3	1	Base plate, Al, 1 mm; with drilled holes for horizontal mounting of euroboards
4	1	Cover plate, Al, 1 mm; with drilled holes for horizontal mounting of euroboards
5	2	Side panel, Al extrusion, raw; with grooves for threaded insert (2 x 7)
6	1	Assembly kit

Order Information

Height U	Height H mm	Depth T mm	Part no.
1	43.7	220	20860-641
1	43.7	280	20860-642
2	88.1	280	20860-645
EMC gasketing kit PU 1 kit			20860-130
Front handles for 1 U PU 2 pieces			20860-256
Front handles for 2 U PU 2 pieces			20860-257
Euroboard mounting kit for EN 60603 connector for 1 U PU 1 kit			20860-115
Euroboard mounting kit for EN 60603 connector for 2 U PU 1 kit			20860-117
Euroboard mounting kit for insulated backplane mounting for 1 U PU 1 kit			20860-116
Euroboard mounting kit for insulated backplane mounting for 2 U PU 1 kit			20860-118

Note

- Threaded inserts to push into the side panel see page 6.121
- Guide rails see page 6.124
- Telescopic slides to mount into cabinet see page 6.125

 For further information www.schroff.biz/oneclick
oneClick search code = Part no.

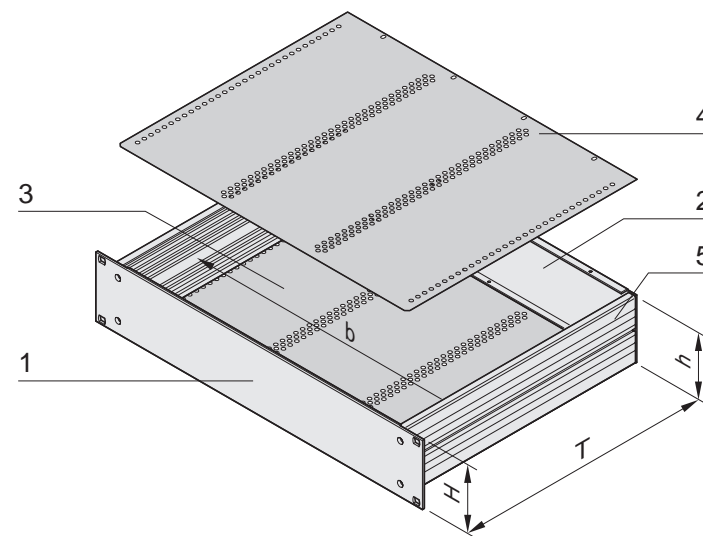

h = clear height (overall) (H - 8.1 mm)
b = clear installation width = 403 mm

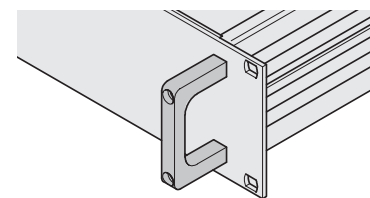

Front handle



ServicePLUS see page 6.118

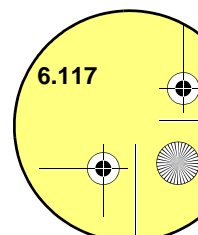

19" chassis - *multipacPRO* ServicePLUS



configuration

Simple. Fast. For the product you want.

Components can be varied and combined freely

- Configuration tables from page 6.119
- Online configuration: www.schroff.co.uk/configuration



assembly

Assembled by professionals. Double benefit!

Fitting of all mechanical, electrical and electronic components by our specialists

- Professional and reliable from quantity 1
- Ready for despatch within 5 working days



modification

Small changes. Large impact.

Custom drillings, cut-outs and special colours for off-the-shelf products

- Custom modifications from quantity 1
- Ready for despatch within 10 working days

**FRONTPLATTEN
EXPRESS**



solution

Simple. Fast. From one source.

Integration and custom developments

- Special sizes (depth and width)
- Individual heat dissipation concepts
- Ready for dispatch within 10 working days



express

When fast has to be faster.

Delivery time to customer's request

- Express logistics



academy

Knowledge. Sharing. Partnerships.

Knowledge transfer and partnership

- Seminars, CAD drawings, test reports, user reports

19" chassis - *multipacPRO* ServicePLUS

How to configure 19" aluminium chassis

- Select height and depth of the basic kit
- Select further components

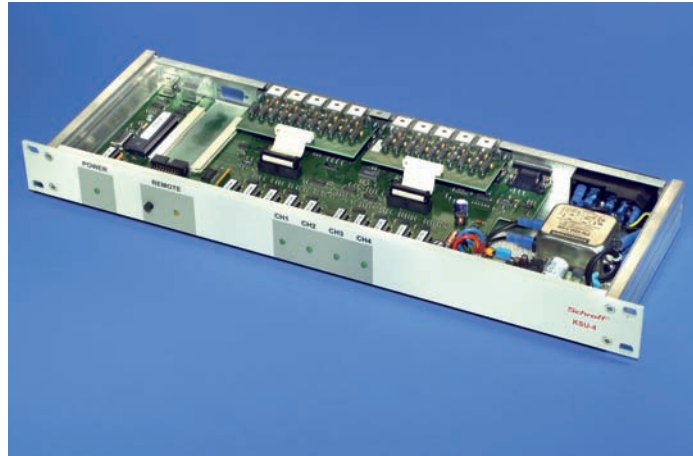

06006001

For non-standardised assemblies (1 ... 5 U)

- Mounting plate
- Top cover/base plate
- Front handles
- EMC gasketing kit
- Telescopic slides

Note

- Non-standardised assemblies see from page 6.120

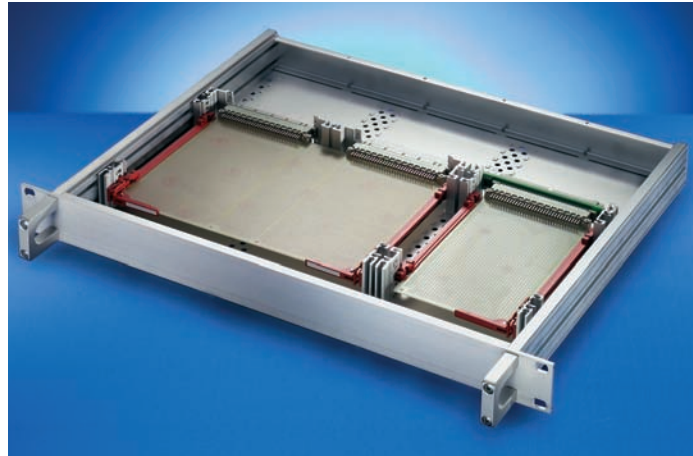

06002001

For standardised assemblies (1, 2 U) in accordance with IEC 60297 -3-100, -101, -105

- Top cover/base plate for horizontal board mounting
- Internal connector or backplane fitting
- Front handles
- EMC gasketing kit
- Telescopic slide

Note

- Standardised assemblies from page 6.122

19" chassis - *multipacPRO* ServicePLUS

Individual components 19" chassis for non-standardised assemblies

- Please select:
 - Height and depth of basic kit (1 ... 5 U, item 1+2+5)
 - Mounting plate
 - Top cover/base plate (item 3+4)
 - Front handles
 - EMC gasketing kit
 - Telescopic slides
- In accordance with IEC 60297-3-105

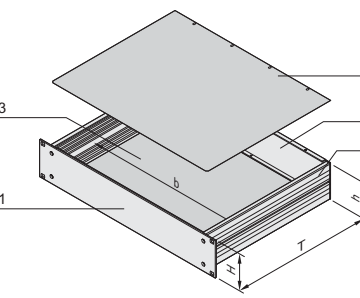
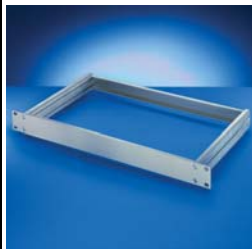
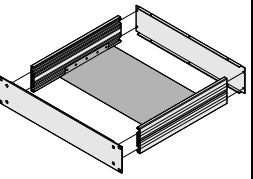
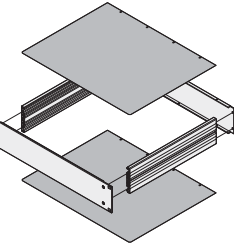
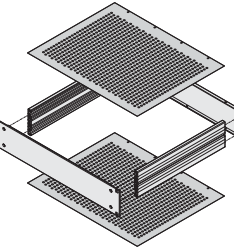

Order Information

				Basic kit	Mounting plate	Top cover/base plate		
						plain	perforated	
 <p>06008052</p> <p>h = clear height (overall) (H - 8.1 mm) b = clear installation width = 403 mm</p>				 <p>06002004</p> <p>1 x Al front panel, 3 mm; 2 x extruded Al side panels; 1 x Al rear panel, 2 mm, incl. fixing material kit</p>	 <p>06002058</p> <p>Al plate, 2 mm; threaded insert, St, 2 mm, zinc-plated, height 7 mm, length 431.3 mm, M3 hole clearance 1 HP = 5.08 mm; for heavy equipment</p>	 <p>06002053</p> <p>is inserted into the basic kit, Al, 1 mm, passivated; please order EMC gasketing kit separately</p>	 <p>06007050</p> <p>is inserted into the basic kit, Al, 1 mm, passivated; hole diameter 4 mm, perforation ratio 58 %</p>	
Height U	Height mm	Width HP	Depth mm	PU 1 kit	Depth mm	1 piece	1 piece	1 piece
1	43.7	84	220	20860-201	150	20860-107	30860-501	30860-510
1	43.7	84	280	20860-202	210	20860-108	30860-502	30860-511
1	43.7	84	340	20860-203	270	20860-109	30860-503	30860-512
2	88.1	84	220	20860-210	150	20860-107	30860-501	30860-510
2	88.1	84	280	20860-211	210	20860-108	30860-502	30860-511
2	88.1	84	340	20860-212	270	20860-109	30860-503	30860-512
3	132.6	84	280	20860-219	210	20860-108	30860-502	30860-511
3	132.6	84	340	20860-220	270	20860-109	30860-503	30860-512
3	132.6	84	400	20860-221	330	20860-110	30860-504	30860-513
3	132.6	84	460	20860-222	390	20860-111	30860-505	30860-514
4	177.0	84	280	20860-228	210	20860-108	30860-502	30860-511
4	177.0	84	340	20860-229	270	20860-109	30860-503	30860-512
4	177.0	84	400	20860-230	330	20860-110	30860-504	30860-513
4	177.0	84	460	20860-231	390	20860-111	30860-505	30860-514
5	221.5	84	460	20860-240	390	20860-111	30860-505	30860-514

19" chassis - *multipacPRO* ServicePLUS

Individual components 19" chassis for non-standardised assemblies

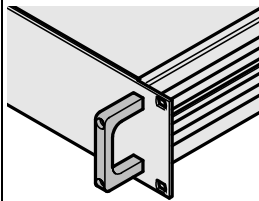
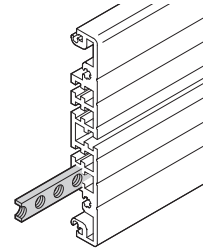
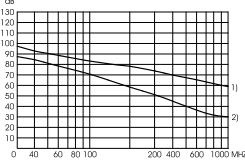
Order Information

				Front handles  06002052 Al extrusion, anodised, incl. assembly kit see page 5.108	Threaded insert M3 for extruded side panel  06007051 St, 2 mm, zinc-plated, height 7 mm, length 431.3 mm, M3 hole clearance 1 HP = 5.08 mm	EMC gasketing kit Shielding upgrade of approx. 30 dB  esa44237 Gasket 2100 mm, silicone/nickel, for contacting side panel/ top cover and base plate; sawtooth gasket 400 mm; stainless steel, for contacting front panel/ top cover and base plate	Assembly kit for telescopic slides  06094004 Assembly kit and adaptor bracket for the cabinets VARISTAR, eurorack, minirack; for mounting the 19in. chassis on telescopic slides; please order telescopic slides separately see page 6.125
Height U	Height mm	Width HP	Depth D mm	PU 2 pieces	1 piece	PU 1 kit	PU 1 kit
1	43.7	84	220	20860-256	30821-589	20860-130	20860-131
1	43.7	84	280				
1	43.7	84	340				
2	88.1	84	220				
2	88.1	84	280	20860-257			
2	88.1	84	340				
3	132.6	84	280				
3	132.6	84	340	20860-258			
3	132.6	84	400				
3	132.6	84	460				
4	177.0	84	280	20860-259			
4	177.0	84	340				
4	177.0	84	400				
4	177.0	84	460				
5	221.5	84	460	20860-260			

Note

- Further sizes available on request
- Al extrusion side panels up to 1000 mm length available on request
- Telescopic slides see page 6.125

19" chassis - *multipacPRO* ServicePLUS

Individual components 19" chassis for standardised 19" assemblies

- Please select
 - Height and depth of basic kit (1, 2 U, items 1+2+5)
 - Top cover/base plate for horizontal board mounting (items 3+4)
 - Internal mounting for connector or backplane
 - Front handles
 - EMC gasketing kit
 - Telescopic slides
- In accordance with IEC 60297-3-100, 101, 105

Order Information

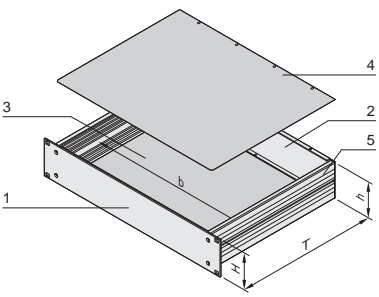
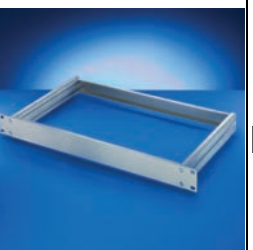
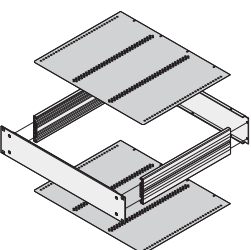
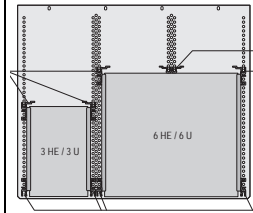
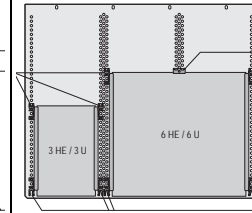

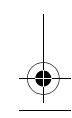
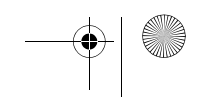
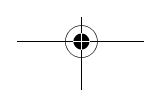
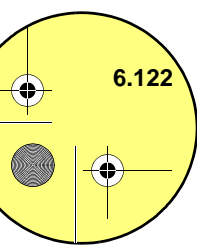
 h = clear height (overall) (H - 8.1 mm) b = clear installation width = 403 mm				 Basic kit 06002004 1 x Al front panel, 3 mm; 2 x extruded Al side panels; 1 x Al rear panel, 2 mm, incl. fixing material kit	 Top cover/base plate 06008053 Al, 1 mm; with drilled holes for horizontal mounting of euroboards	Mounting of euroboards	
				 for EN 60603 connectors 06003050 2 x front horizontal rails, 2 x rear horizontal rails with Z, 2 x threaded inserts; Sufficient for one 3 U board or one 6 U board	 for insulated backplane assembly 06003051 2 x front horizontal rails, 2 x rear horizontal rails, 4 x threaded inserts, 4 x insulation strips PBT, UL 94; Sufficient for one 3 U board or one 6 U board (6 HP for 1 U, 15 HP for 2 U)		
Height U	Height mm	Width HP	Depth D mm	PU 1 kit	1 piece	PU 1 kit	PU 1 kit
1	43.7	84	220	20860-201	30860-519	20860-115	20860-116
1	43.7	84	280	20860-202	30860-520	20860-115	20860-116
1	43.7	84	340	20860-203	30860-521	20860-115	20860-116
2	88.1	84	220	20860-210	30860-519	20860-117	20860-118
2	88.1	84	280	20860-211	30860-520	20860-117	20860-118
2	88.1	84	340	20860-212	30860-521	20860-117	20860-118



19" chassis - *multipacPRO* ServicePLUS

Individual components 19" chassis for standardised 19" assemblies

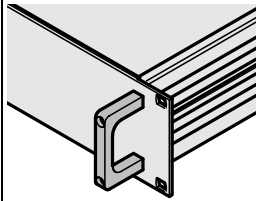
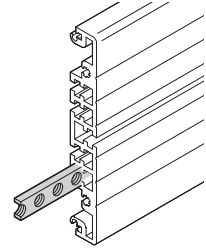
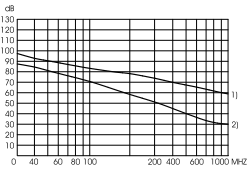
Order Information

Height U	Height mm	Width HP	Depth D mm	Front handles	Threaded insert M3 for extruded side panel	EMC gasketing kit for shielding upgrade of approx. 30 dB	Assembly kit for fixing on telescopic slides
				 06002052 Al extrusion, anodised, incl. assembly kit see page 5.108	 06007051 St, 2 mm, zinc-plated, height 7 mm, length 431.3 mm, M3 hole clearance 1 HP = 5.08 mm	 esa44237 Gasket 2100 mm, silicone/nickel, for contacting side panel/ top cover and base plate; sawtooth gasket 400 mm; stainless steel, for contacting front panel/ top cover and base plate	 06094004 Assembly kit and adaptor bracket for the cabinets VARISTAR, eurorack, minirack; for mounting the 19in. chassis on telescopic slides; please order telescopic slides separately see page 6.125
				PU 2 pieces	1 piece	PU 1 kit	PU 1 kit
1	43.7	84	220	20860-256	30821-589	20860-130	20860-131
1	43.7	84	280				
1	43.7	84	340				
2	88.1	84	220	20860-257			
2	88.1	84	280				
2	88.1	84	340				



Note

- Further sizes available on request
- Al extrusion side panels up to 1000 mm length available on request
- Telescopic slides see page 6.125

19" chassis - *multipacPRO* ServicePLUS

Guide rails for boards without front panels, one-piece, groove width 2 mm

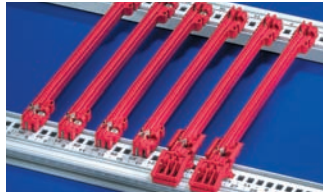
Order Information

Assembly - can be clipped into horizontal rails in Al extrusion - can be clipped into 1.5 mm thick plate		Guide rails "Accessories" 	
Storage temperature from -40 °C ... +130 °C		up to 280 mm length, PBT, UL 94 V-0; > 280 mm length, multi-piece, end piece PBT, UL 94 V-0, middle section Al extrusion	
Board length	Groove width	Colour	
mm	mm	mm	PU 10 pieces ²⁾
160	2	red	24560-373
220	2	red	24560-374
280	2	red	24560-375
340	2	red	24560-376
Retention screw, PU 100 pieces 		24560-141	

2) Part no. includes one packing unit (PU); delivery is exclusively made in PU

Guide rail accessories

Order Information

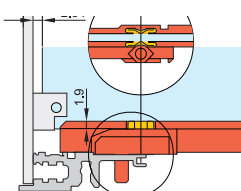
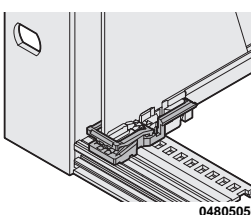
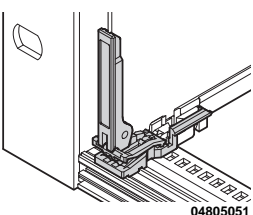
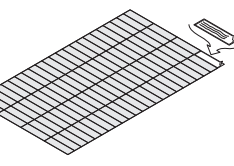
ESD clip for guide rails  <p>04503050</p> <p>Spring steel, tin-plated, ensures conductive contact between board and horizontal rail, on both the solder side and the component side</p> <p>PU 50 pieces 24560-255</p>	Board locking for PCBs without front panel  <p>04805050</p> <p>PBT, UL 94 V-0, red, to fix the PCB in the subrack (also slot 1), can also be used without board handle, minimum distance 3 HP</p> <p>PU 10 pieces 24560-377</p>	Board handle for board locking  <p>04805051</p> <p>PBT, UL 94 V-0, red, insertion/extraction function with connection to board locking (also slot 1), mounting directly behind front panel (upper and lower), minimum distance 3 HP</p> <p>PU 10 pieces 24560-378</p>	Identification strips for board handle  <p>06108076</p> <p>Polyester film, 31 x 4 mm, self-adhesive, white/matt (1 A4 sheet contains 438 pieces) PBT, UL 94 V-0</p> <p>1 piece 60817-228</p>
--	--	--	--

19" chassis - *multipacPRO* ServicePLUS

Universal 1 U telescopic slide

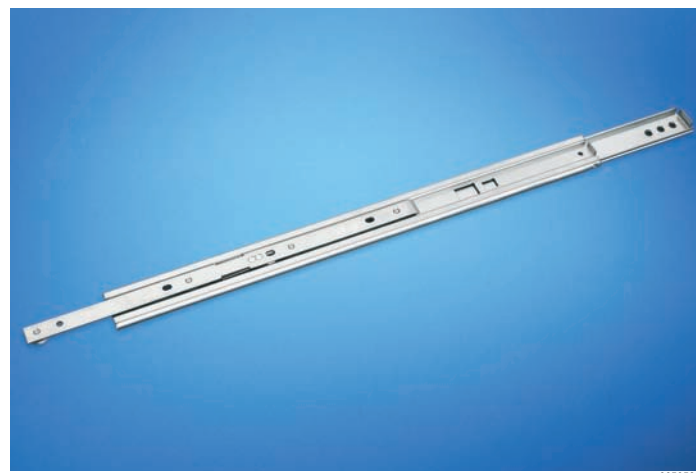

- Static load-carrying capacity per pair 23 - 39 kg
- Lateral mounting on the 19" uprights (19" plane remains free for fixing the extension/drawer)
- Can be removed
- Extension length > 100 %
- Rail width $k = 9.7$ mm, max. installation width of extension/drawer $w = 429$ mm

Delivery comprises

Item	Qty	Description
1	2	Telescopic slide, St, zinc-plated

Order Information

Length L	Extension length Y	Load-carrying capacity P	Part no.
mm	mm	kg	
356	381	39	20110-090
406	432	36	20110-091
457	483	34	20110-092
508	533	32	20110-093
559	584	29	20110-094
610	635	27	20110-095
660	686	23	20110-096
711	737	23	20110-097

Note

- For mounting into Schroff cabinets please order assembly kit separately, see page 6.123

For further information www.schroff.biz/oneclick
oneClick search code = Part no.

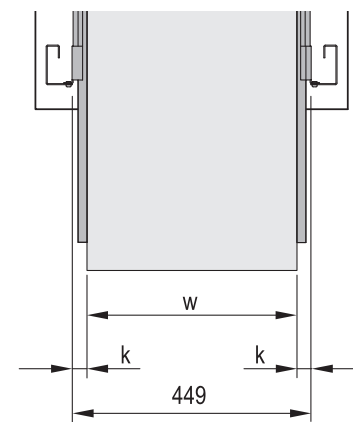

k = rail width, w = max. installation width

Dimensions table

L	Internal part								External part		
	A	B	C	D	E	F	G	X	O	P	Q
356	29.5	92.1	184.2	276.2	-	-	-	349.3	304.6	317.3	330.0
406	29.5	92.1	184.2	276.2	-	-	-	349.3	355.4	368.1	380.8
457	29.5	92.1	184.2	276.2	-	-	-	349.3	406.4	419.1	431.8
508	89.9	92.1	184.2	276.2	368.3	-	-	501.7	457.4	470.1	482.8
559	89.9	92.1	184.2	276.2	368.3	-	-	501.7	508.1	520.8	533.5
610	89.9	92.1	184.2	276.2	368.3	-	-	501.7	558.6	571.3	584.0
660	7.4	92.1	184.2	276.2	368.3	460.4	552.4	603.3	609.4	622.1	634.8
711	7.4	92.1	184.2	276.2	368.3	460.4	552.4	603.3	660.2	672.9	685.6

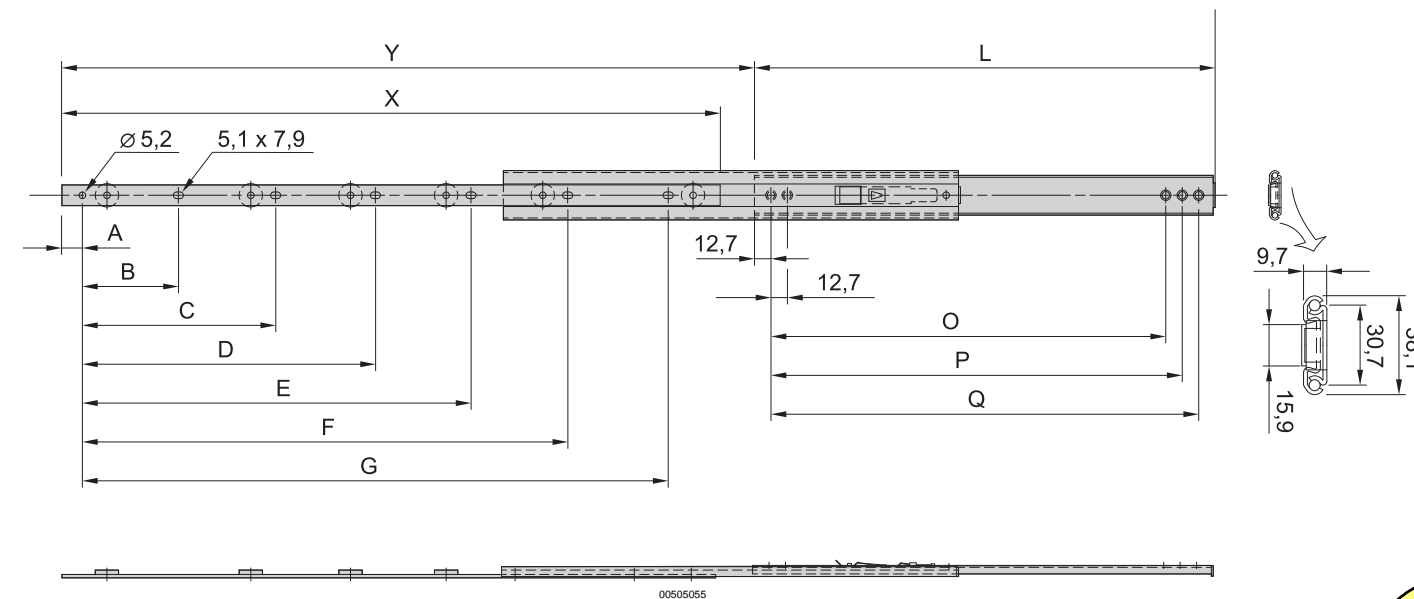

19" chassis - *multipacPRO* ServicePLUS

Universal 2 U, slim telescopic slide



- Static load-carrying capacity per pair 46 - 57 kg
- Lateral mounting on the 19" uprights (19" plane remains free for fixing the extension/drawer)
- Locking at full extension
- Extension length > 110 %
- Rail width $k = 9,7$ mm, max. installation width of extension/drawer $w = 429$ mm

Delivery comprises

Item	Qty	Description
1	2	Telescopic slide, St, zinc-plated

Order Information

Length L	Extension length Y	Load-carrying capacity P	Part no.
mm	mm	kg	
356	432	57	20110-071
406	483	55	20110-072
457	533	55	20110-073
508	584	55	20110-074
559	635	46	20110-075
584	660	46	20110-076
610	686	46	20110-077

Accessories

Assembly kit for VARISTAR,
for assembly of 2 telescopic slides, PU 1 kit

21120-161

Assembly kit for eurorack,
for assembly of 2 telescopic slides, PU 1 kit

21120-162

Telescopic slides mounting kit for NOVASTAR,
to mount 2 telescopic slides, PU 1 kit

21120-163

Delivery: supplied loose with cabinet or frame Part no./35

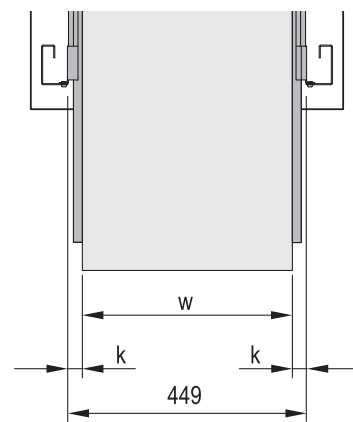

k = rail width, w = max. installation width

Dimensions table

Length L	Internal part				External part		
	A	w	C	X	D	E	F
356	101.6	184.2	304.8	356.0	101.6	228.6	330.2
406	127.0	209.6	355.6	406.0	127.0	254.0	381.0
457	127.0	235.0	406.4	457.0	152.4	279.4	431.8
508	152.4	260.4	457.2	508.0	152.4	330.2	482.6
559	203.2	412.8	508.0	559.0	177.8	355.6	533.4
584	203.2	431.8	533.4	584.0	177.8	381.0	558.8
610	203.2	438.2	558.8	610.0	203.2	381.0	584.2

Note

- To mount on 19" plane please order assembly kit separately
- Universal telescopic rails can also be fitted without additional components in non-standard applications, thus also in other than 19" cabinets

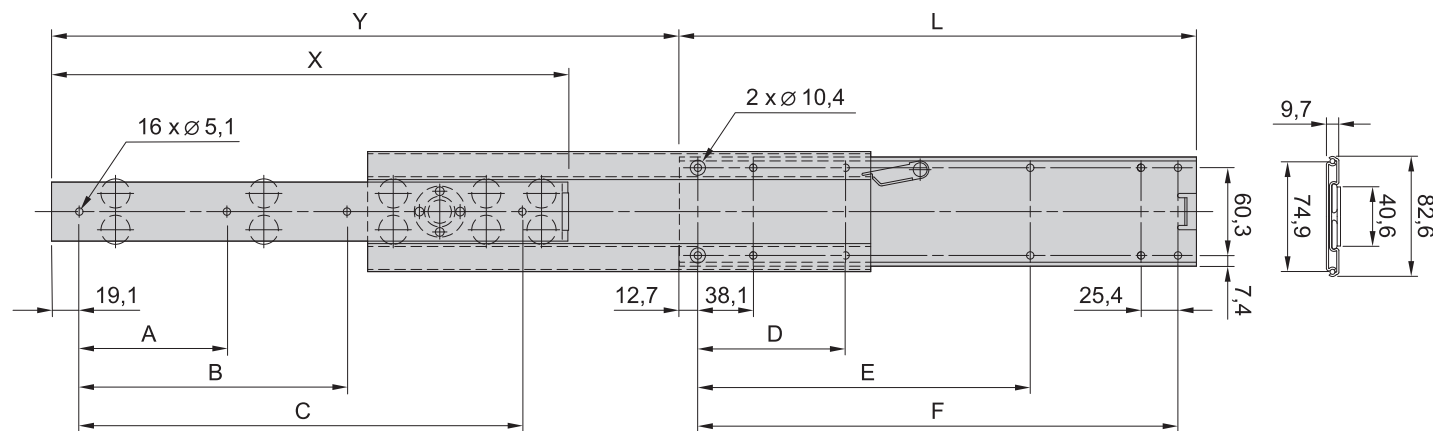

00505059

19" chassis - **multipacPRO** ServicePLUS

Customised solutions



06002006

Application: Different cut-outs

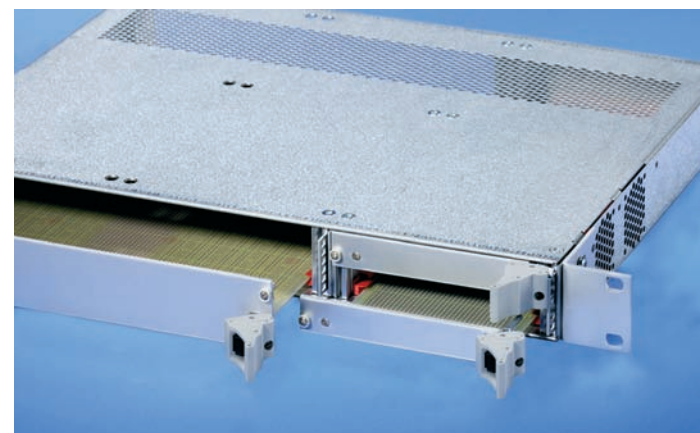

06002007

Application: Combined 3 U and 6 U assembly



06002005

Application: 2 U version with 2 x 3 U assembly



06008006

Application: 1 U multipacPRO (pizza box) complete from steel plate; 19" brackets can be removed if required



06108007

Application: 1 U multipacPRO complete from steel plate; front panel in aluminium with cut-outs



06101008

Application: 1 U multipacPRO complete from steel plate; printed 19" front panel in aluminium with cut-outs

- Overview 0
- Cabinets 1
- Wall mounted cases 2
- Accessories for cabinets and wall mounted cases 3
- Climate control 4
- Desk-top cases 5
- Subracks/
19" chassis ... 6**
- Front panels, plug-in units .. 7
- Systems 8
- Power supply units 9
- Backplanes .. 10
- Connectors, front panel component system 11
- Appendix 12

19" chassis - *inpac*



02192001

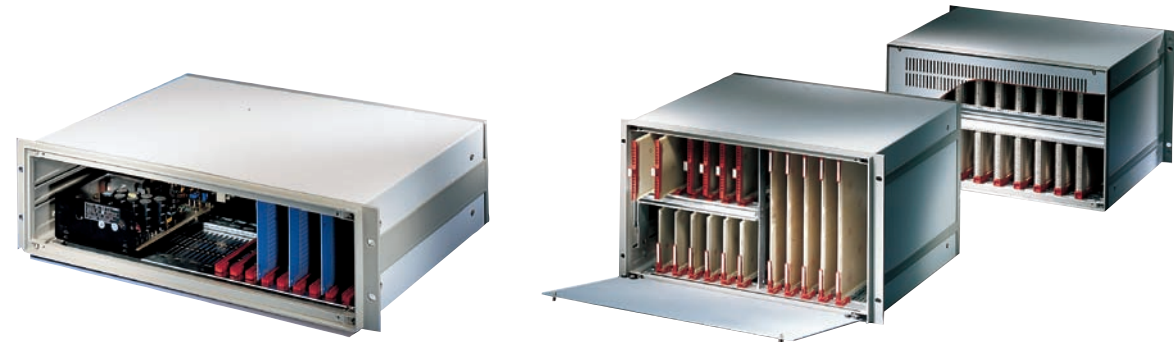

Robust 19" chassis, also for board assembly

02192005

Assembly with boards and hinged front panel

02196001

Standards

- External dimensions in accordance with:
IEC 60297-3-101
- Ingress protection IP 20 to IEC 60529
- GND/earthing connectors to:
DIN EN 50178/VDE 0160
DIN EN 60950/VDE 0805
DIN EN 61010-1/VDE 0411 part 1
DIN EN 61010-1A2/VDE 0411 part 1/A1



Downloads and further important information can be found on the Internet under www.schroff.biz

19" chassis with high mechanical stability

- Also usable as desk-top case
- Robust cases from aluminium die-cast frames to front and rear
- Flexible assembly for standardised board formats or individually, e.g. for mounting plates
- Cost benefit with mounting service and custom processing in ServicePLUS



19" chassis/desk-top enclosure

- 2 U, 3 U, 4 U and 6 U heights

02192002



inpac built into 19" cabinet

02192003



30407004

ServicePLUS from page 6.118

- e.g. individual configuration and assembly from 1 piece
- e.g. printing
- e.g. cut-outs in front or rear panels or cover plates
- e.g. modification (special colours)
- e.g. custom solutions (special depths, electromagnetically shielded applications)

www.schroff.biz/ServicePLUS

inpac

19" chassis 6.130

Accessories

Full-width front panels 6.131

Full-width rear panels 6.131

Support rails ... 6.132

Horizontal rails .. 6.132

Front handles ... 6.133

GND/earthing kit 6.133

Guide rails 6.134

Dimensions 6.136

ServicePLUS . 6.118

19" chassis - *inpac*

19" chassis



- For assembly with 19" components or individually with mounting plates
- Three rows ventilation slots in base for air inlet

Delivery comprises (Kit)

Item	Qty	Description
1	2	Side panel, Al extrusion, RAL 7030, at 6 U: 2 Al corner profiles, 1 divider plate (steel plate)
2	1	Front frame, Al die-cast, RAL 7030, rear side with counterbores for drill holes to mount handles and front panels
3	1	Rear frame, Al die-cast, RAL 7030
4	1	Cover plate, St, 1 mm, RAL 7035, plastic-coated, with GND/earthing connection
5	1	Base plate, St, 1 mm, RAL 7035, plastic-coated, with GND/earthing connection
6	4	Case foot with anti-slip protection, PC, UL 94 V-0
7	1	Assembly kit

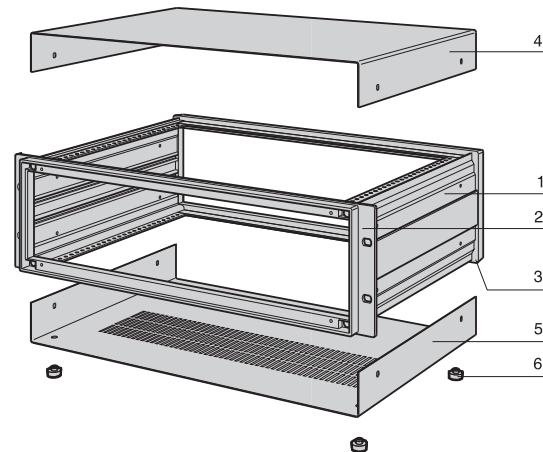

02192006

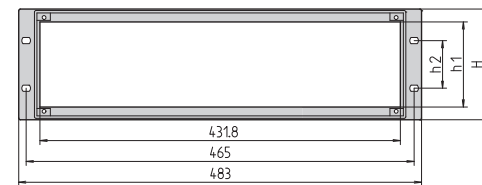

ipa30632

IPA30635

Order Information

Height H	Height H	h	h1	h2	Depth D	Part no.
U	mm	mm	mm	mm	mm	
2	88.0	86.0	57.5	76.2	254.5	10828-071
2	88.0	86.0	57.5	76.2	314.5	10828-072
2	88.0	86.0	57.5	76.2	374.5	10828-073
3	132.5	130.5	102.0	57.1	254.5	10828-051
3	132.5	130.5	102.0	57.1	314.5	10828-052
3	132.5	130.5	102.0	57.1	374.5	10828-053
3	132.5	130.5	102.0	57.1	434.5	10828-054
4	177.0	174.5	146.5	101.6	254.5	10828-056
4	177.0	174.5	146.5	101.6	314.5	10828-057
4	177.0	174.5	146.5	101.6	374.5	10828-058
4	177.0	174.5	146.5	101.6	434.5	10828-059
6	265.9	263.5	235.4	190.5	374.5	10828-068
6	265.9	263.5	235.4	190.5	434.5	10828-069

Note

- Max. installation space when fitting 19" components is 75 HP
- Scope of delivery includes screws to fix rear and front panels



For further information www.schroff.biz/oneclick
oneClick search code = Part no.

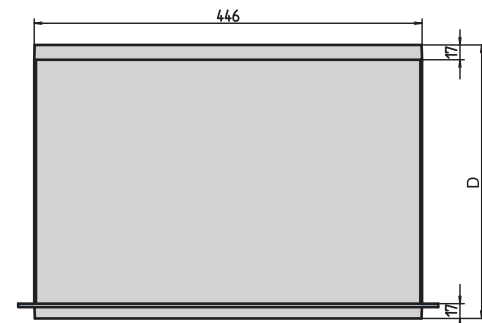

IPA30704

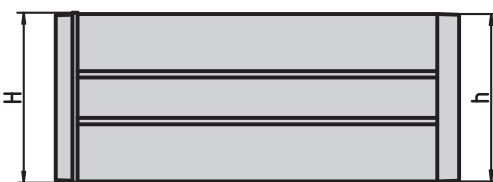

IPA30706



ServicePLUS see page 6.118

6.130 Main Catalogue
E 10/2012

Part number in bold face type: ready for despatch within 2 working days
Part number in normal type: ready for despatch within 10 working days

19" chassis - *inpac*

Front panel

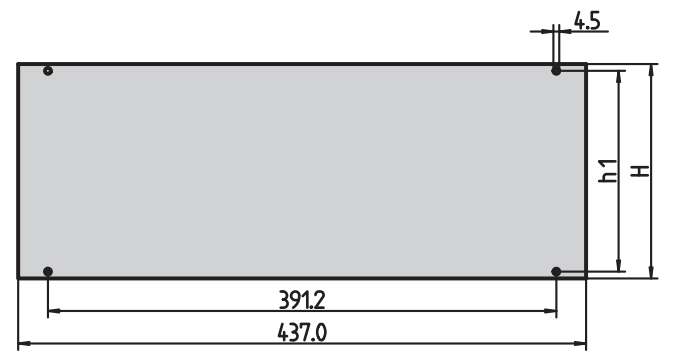

Delivery comprises

Item	Qty	Description
1	1	Front panel, Al, 2.5 mm, anodised, cut edges untreated

Order Information

Height U	Height H mm	h1 mm	Part no.
2	76.0	65.6	30828-055
3	120.5	110.0	30828-058
4	165.0	154.5	30828-061
6	253.8	243.4	30828-067

Note

- The assembly kit for the front panel is included with the 19" chassis

Front panel, bottom-hinged

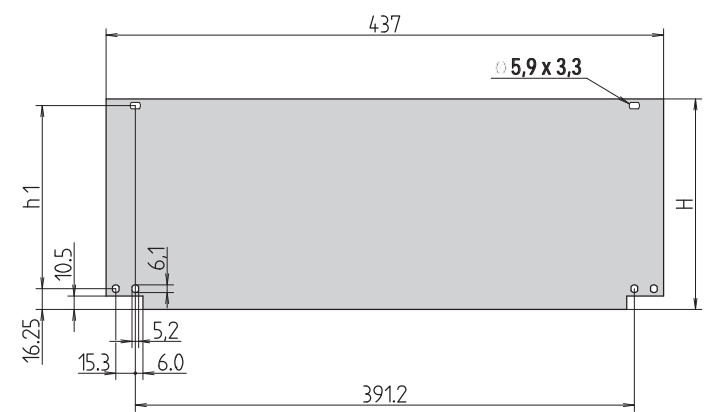

Delivery comprises

Item	Qty	Description
1	1	Front panel, hinged, Al, 2.5 mm, anodised, cut edges untreated

Order Information

Height U	Height H mm	h1 mm	Part no.
2	76.0	54.5	30828-085
3	120.5	99.0	30828-088
4	165.0	143.5	30828-091
6	253.8	232.3	30828-097

Hinge for front panel PPE, UL 94 V-0, PU 1 kit (includes fixing material kit and 2 collar screws) 20828-028

Note

- Please order hinge for front panel separately

Rear panel with ventilation openings

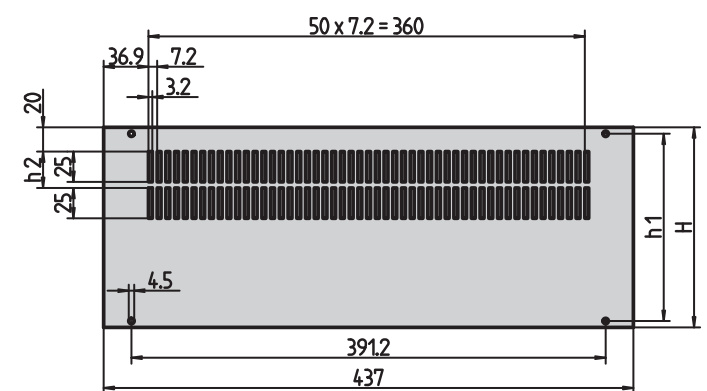

Delivery comprises (kit)

Item	Qty	Description
1	1	Rear panel, incl. assembly kit, Al, 2.5 mm, anodised, cut edges untreated

Order Information

Height U	Height H mm	h1 mm	h2 mm	Part no.
2	76.0	65.6	-	30828-070
3	120.5	110.0	-	30828-073
4	165.0	154.5	-	30828-076
6	253.8	243.4	30	30828-082

Note

- The scope of delivery of the 19" chassis includes an assembly kit for the front panel

19" chassis - *inpac*

Support rail for guide rails

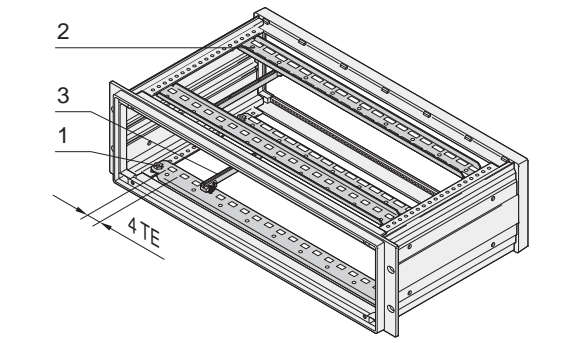

- 4 support rails to fix PCBs with guide rails
- Support rail can also be used to fix a custom mounting plate

Order Information

Item	Description	Part no.
1	front support rail, St, 1.5 mm, blue-passivated, 1 piece	30828-165
2	rear support rail, St, 1.5 mm, blue-passivated, 1 piece	30828-174

Accessories

Guide rail 160 mm (Item 3), PBT, UL 94 V-0, with integrated fixture for connector to EN 60603 (DIN 41612), PU 1 pair 60817-078

Guide rail 220 mm (Item 3), PBT, UL 94 V-0, with integrated fixture for connector to EN 60603 (DIN 41612), PU 1 pair 60817-079

Screw for mounting of support rails, M4 x 8, flathead bolts with posidrive, PU 100 pieces 21100-677

- Guide rails see page 6.134

 For further information www.schroff.biz/oneclick
oneClick search code = Part no.

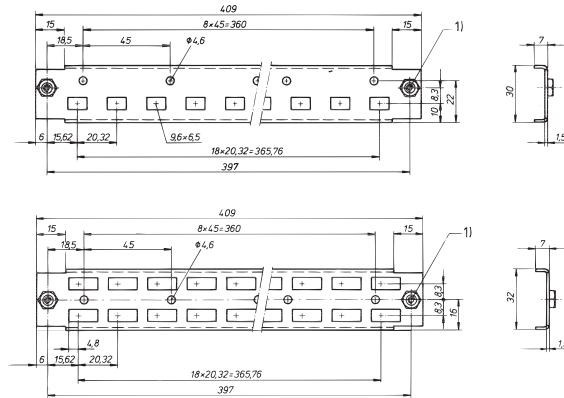

IPA30639

a3-306xx

Dimension drawing top: Front support rail,
dimension drawing bottom: rear support rail;
1) bush M4, pressed-in

Horizontal rail for guide rails, backplane and connector mounting

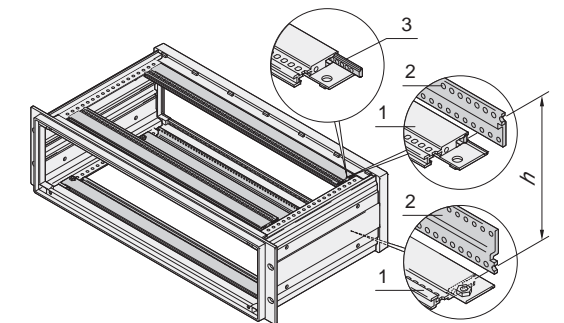

- 4 horizontal rails to fix guide rails (for PCBs) and for backplane or connector mounting
- Useable width 75 HP

Order Information

Item	Description	Qty/PU	Part no.
1	Horizontal rail 75 HP, Al extrusion, anodised	1	30828-128

Accessories

Z-rail (item 2), Al extrusion, anodised, 1 piece 30814-513

Threaded insert (item 3), St, zinc-plated (blue), 1 piece 30819-604

Screw to fix horizontal rails, M4 x 8, Pozidrive flathead screw, 100 pieces 21100-677

Cheesehead screw with slot M2.5 x 6, DIN 84, PU 100 pieces M2.5 x 6, DIN 84, 100 pieces 21100-146

Note

- Threaded inserts cannot be used at front
- For backplane mounting, threaded inserts are required in the rear horizontal rails
- For connector mounting, threaded inserts and Z-rails are required in the rear horizontal rails
- Guide rails see page 6.134

Item 1: horizontal rail, item 2: Z-rail, item 3: threaded insert

IPA30640

h	Bolt-on dimension of backplane
U	mm
2	75.40
3	119.80
4	164.30
6	252.90

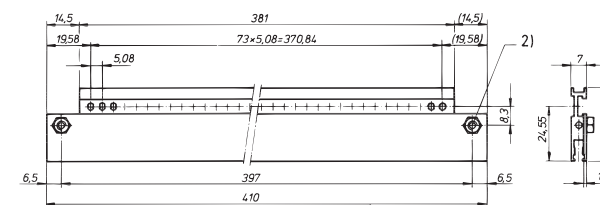

A4-587

2) bush M4, pressed-in

19" chassis - *inpac*

Front handles

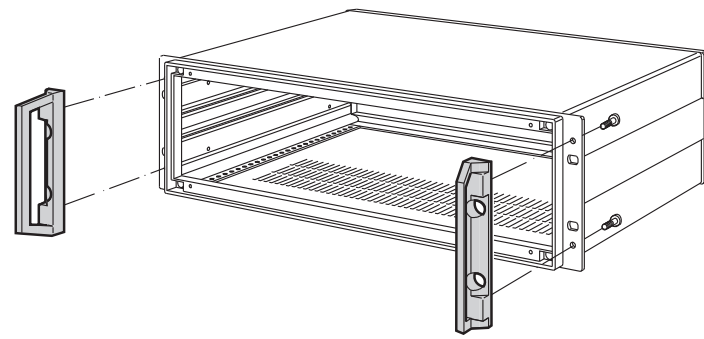

- Load-carrying capacity 35 kg per pair

Delivery comprises (kit)

Item	Qty	Description
1	2	Front handle, Al die-cast, powder-coated, RAL 7030, incl. assembly kit

Order Information

Height	Part no.
U	
3	20828-127
4	20828-128
6	20828-129



For further information www.schroff.biz/oneclick
oneClick search code = Part no.

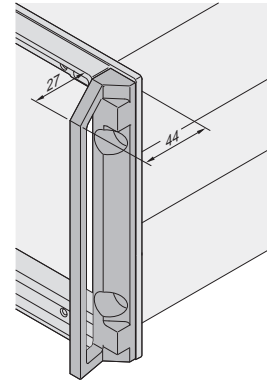

02108050

GND/earthing kit

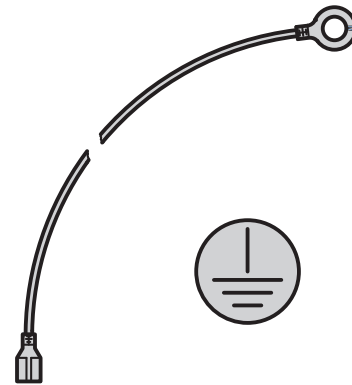

- The GND/earthing kit allows VDE-compliant earthing of the case to:
 - DIN EN 50178/VDE 0160
 - DIN EN 60950/VDE 0805
 - DIN EN 61010-1/VDE 0411 Part 1
 - DIN EN 61010-1A2/VDE 0411 Part 1/A
- VDE inspection has been carried out

Order Information

Description	Qty/PU	Part no.
GND/earthing kit, Cu wire, 1.5 mm ² , PVC sleeve, green/yellow, links side panels, top cover, base plate and rear panel	1	21100-814

az843284



For further information www.schroff.biz/oneclick
oneClick search code = Part no.

19" chassis - *inpac*

Guide rails

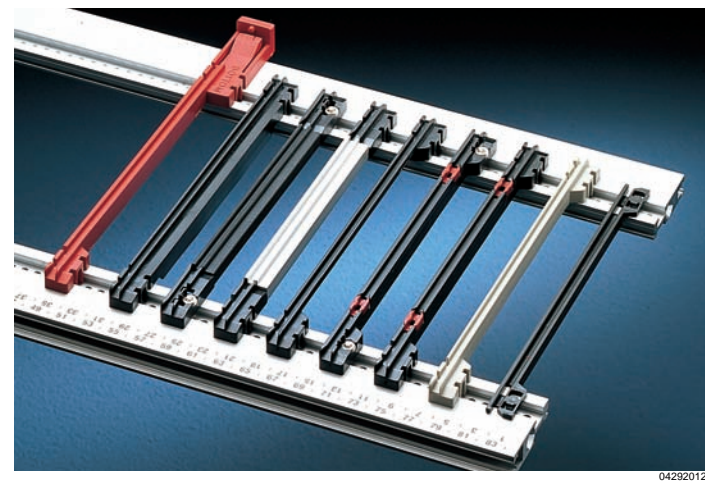

04292012

Order Information

Board lengths mm mm	Groove width mm mm	Light version, snap-in		Version with board fixing, snap-in		Version with board fixing, bolt-on		Version for heavy load-carrying capacity, snap-in		Version with ESD clip		Universal version with AI middle section, bolt-on	
		Part no.	Part no.	Part no.	Part no.	Part no.	Part no.	Part no.	Part no.	Part no.	Part no.		
		1 piece (SPQ 50) ¹⁾	1 piece (SPQ 50) ¹⁾	1 piece (SPQ 50) ¹⁾	1 piece (SPQ 50) ¹⁾	1 piece (SPQ 50) ¹⁾	1 piece (SPQ 50) ¹⁾	1 piece (SPQ 50) ¹⁾	Qty/PU 1 piece	Qty/PU 1 piece	Qty/PU 1 piece	Qty/PU 1 piece	
100	2	-	60817-015	-	-	-	-	-	-	-	-	-	
160	2	60817-064	60817-103	60817-001	60817-053	60817-102	20817-368	-	-	-	-	-	
160	2.5	-	60817-076	-	-	-	-	-	-	-	-	-	
180	2	-	-	60817-026	-	-	-	-	-	-	-	-	
220	2	-	60817-149	60817-016	60817-083	60817-085	20817-369	-	-	-	-	-	
220	2.5	-	-	-	-	60817-098	-	-	-	-	-	-	
280	2	-	-	-	-	60817-080	-	-	-	-	-	-	
340	2	-	-	-	-	-	-	-	-	-	20825-120	-	
400	2	-	-	-	-	-	-	-	-	-	20825-121	-	

1) SPQ (standard pack quantity): Part number includes 1 piece, but delivery is exclusively made in standard pack quantity (SPQ); please order at least the SPQ quantity or a multiple

Accessories

Spring clip PPE, UL 94 V-0, red, PU 100 pieces	21100-553	21100-553	-	-	-
Spring clip PPE, UL 94 V-0, red, PU 100 pieces	21100-554	21100-554	-	-	-
Assembly parts for 50 guide rails PU (100 screws, 100 nuts)	-	21101-990	-	-	21101-990

Note

- For a detailed description of the guide rails see our website; please enter part number in "oneclick" search

19" chassis - *inpac*

PCB handle A

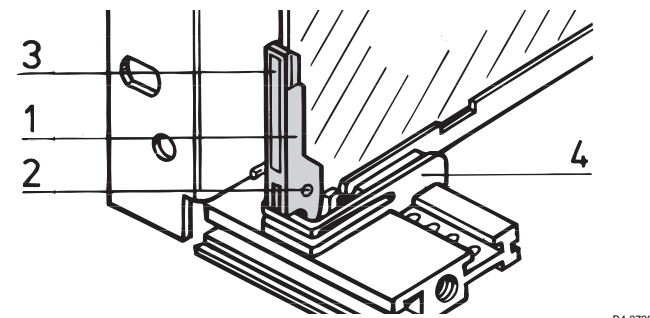

- To be mounted behind front panel, for PCB thickness 1.6 mm
- Insertion and extraction function
- Can be labelled

Order Information

Item	Description	Material	Colour	Qty/PU	Part no.
1	PCB handle A	PBT, UL 94 V-0	red	1 piece (SPQ 10)	60817-096
2	Pivot pin DIN 7	Stainless steel	–	100	21100-671
3	Identification strip	Polyester film, self-adhesive	matt-silver	100	21100-672

SPQ (Standard Pack Quantity): Part number includes 1 piece, but delivery is exclusively made in standard pack quantity: Please order at least 10 pieces PCB handles or a multiple

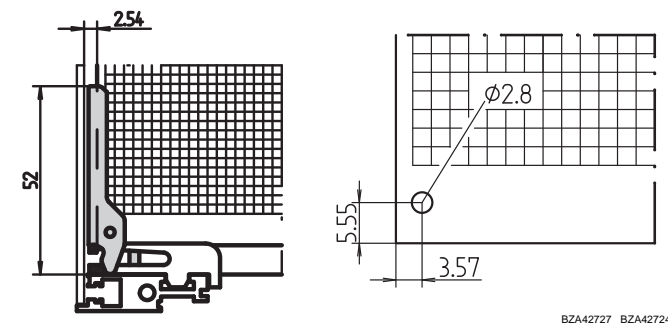

BZA42727 BZA42724

PCB retainer A

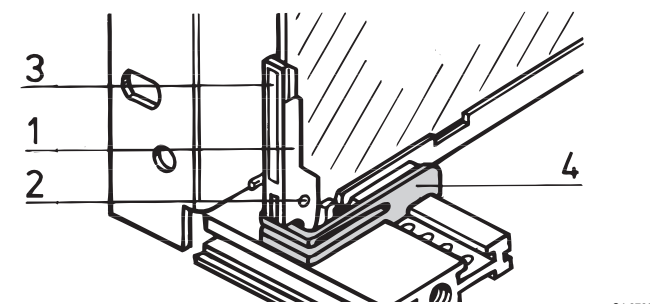

- Can also be used without PCB handle
- Application on top and bottom horizontal rail

Order Information

Item	Description	Material	Colour	Qty	Part no.
4	PCB retainer A for top and bottom	PPE, UL 94 V-0	red	1 piece (SPQ 10)	60817-097

SPQ (Standard Pack Quantity): Part number includes 1 piece, but delivery is exclusively made in Standard Pack Quantity: Please order at least 10 pieces PCB retainers or a multiple

C4-2728

PCB retainer B

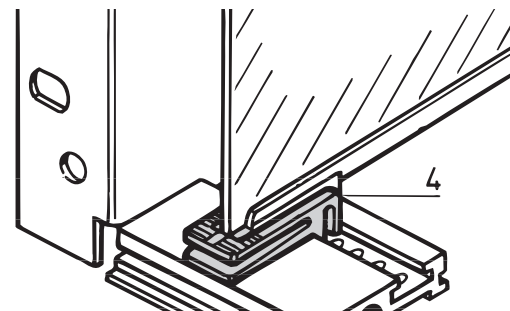

- Can be used on upper and lower horizontal rail, for PCB thickness 1.6 mm
- Can also be used without PCB handle
- Can also be used with guide blocks

Order Information

Item	Description	Material	Colour	Qty	Part no.
4	PCB retainer, bottom	PPE, UL 94 V-0	red	1 piece (SPQ 10)	60817-054
4a	PCB securing top	PPE, UL 94 V-0	black	1 piece (SPQ 10)	60817-071

SPQ (Standard Pack Quantity): Part number includes 1 piece, but delivery is exclusively made in Standard Pack Quantity: Please order at least 10 pieces PCB retainers or a multiple

BZA46428

19" chassis - *inpac*

Dimensions

19" front frame

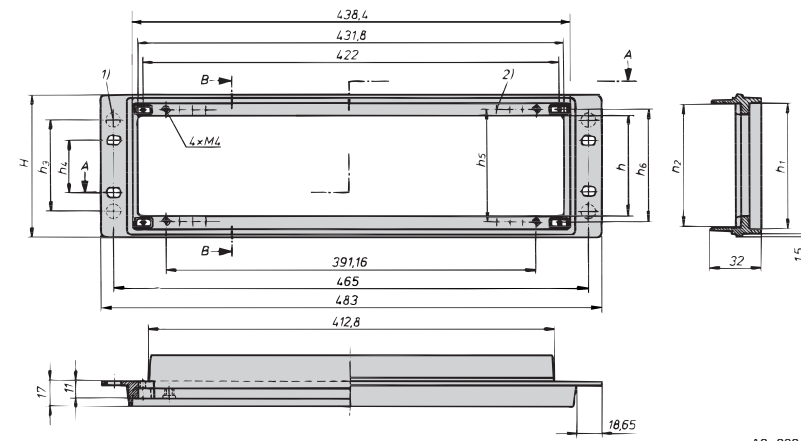

Section A-A

A3-306

There are counterbores at the rear side of the front frame which can be drilled if required:

- 1) For handle mounting
- 2) For mounting of partial-width front panel (grid 5.08 mm)

19" rear frame

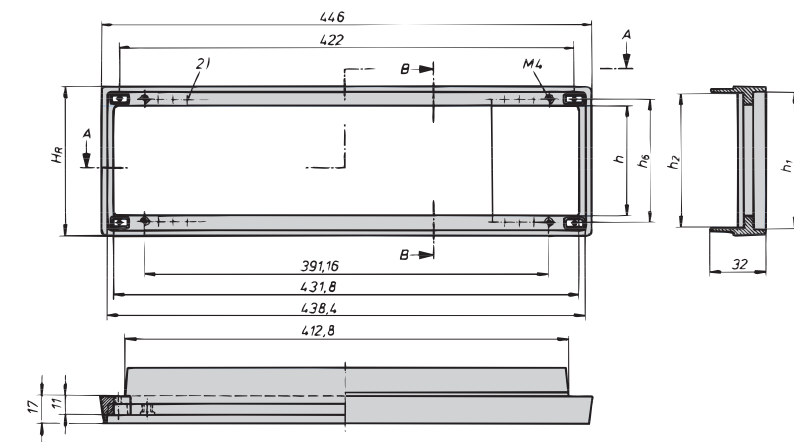

Section A-A

A3-305

Dimensions table

Height										
in U	H	H _R	h	h ₁	h ₂	h ₃	h ₄	h ₅	h ₆	h ₇
2	88,0	86,0	57,5	77,3	69,8	25,0	76,2	65,5	68,0	68,4
3	132,5	130,5	102,5	121,8	114,3	90,0	57,1	110,0	112,5	112,8
4	177,0	175,0	146,5	166,3	158,8	134,5	101,6	154,5	157,0	157,3
6	265,9	263,9	235,4	255,2	247,7	233,4	190,4	243,4	245,9	245,9

19" chassis - *inpac*

Dimensions

Side panel

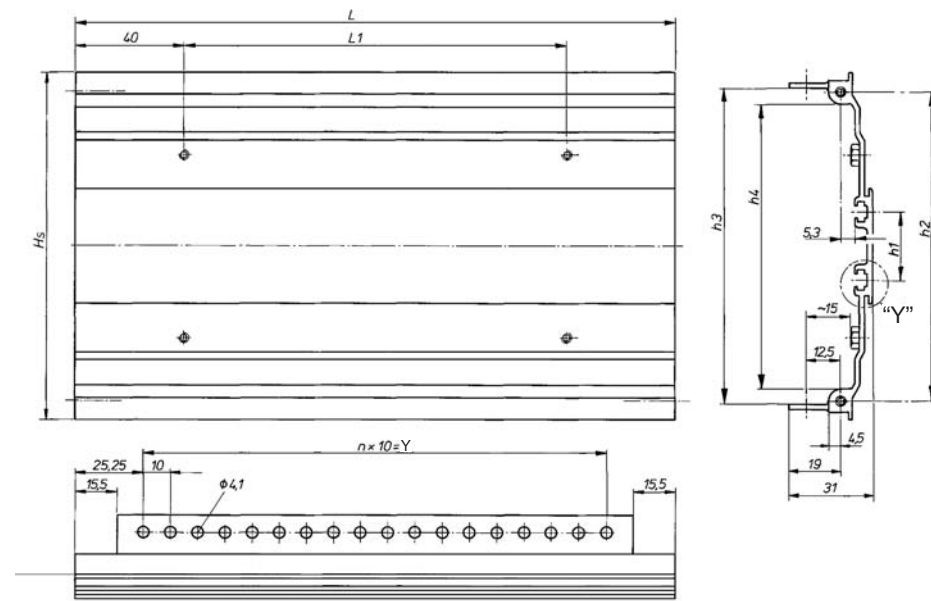

A3-304a

Detail "Y"

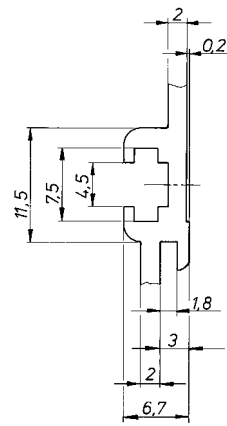

A3-304b

Dimensions table

Height										
in U	H	h ₁	h ₂	h ₃	h ₄	L	L ₁	(n)	Y	T
2	82,6	–	68,0	71,4	59,0	220,5	140,5	17,0	170	254,5
2	82,6	–	68,0	71,4	59,0	280,5	200,5	23,0	230	314,5
2	82,6	–	68,0	71,4	59,0	340,5	260,5	29,0	290	374,5
3	127,0	24,0	112,5	115,8	103,5	220,5	140,5	17,0	170	254,5
3	127,0	24,0	112,5	115,8	103,5	280,5	200,5	23,0	230	314,5
3	127,0	24,0	112,5	115,8	103,5	340,5	260,5	29,0	290	374,5
4	171,0	68,5	157,0	160,3	148,0	220,5	140,5	17,0	170	254,5
4	171,0	68,5	157,0	160,3	148,0	280,5	200,5	23,0	230	314,5
4	171,0	68,5	157,0	160,3	148,0	340,5	260,5	29,0	290	374,5
6	260,4	157,1	245,9	248,9	236,5	220,5	140,5	17,0	170	254,5
6	260,4	157,1	245,9	248,9	236,5	280,5	200,5	23,0	230	314,5
6	260,4	157,1	245,9	248,9	236,5	340,5	260,5	29,0	290	374,5



MAIN CATALOG

24TH EDITION



Schroff® MAIN CATALOG

EQUIPMENT PROTECTION SOLUTIONS

24TH EDITION | OCTOBER 2012



SCHROFF GMBH, LANGENALBER STRASSE 96-100, D-75334 STRAUBENHARDT WWW.PENTAIREQUIPMENTPROTECTION.COM

39601-641 © 2012 Pentair Equipment Protection

X-ON Electronics

Largest Supplier of Electrical and Electronic Components

Click to view similar products for [schroff](#) manufacturer:

Other Similar products are found below :

[24566-125](#) [14575171](#) [14575271](#) [14576145](#) [14575265](#) [20117-156](#) [20817772](#) [20827088](#) [20846211](#) [20860229](#) [21100777](#) [23022602](#) [23130082](#)
[24571331](#) [24571586](#) [24572066](#) [24822075](#) [26230-374](#) [30817-001](#) [30825080](#) [20849021](#) [20860240](#) [23001021](#) [24560080](#) [24571303](#)
[24572054](#) [24572056](#) [30219-113](#) [20848-410](#) [20838-125](#) [20860-601](#) [20860-633](#) [10225-602](#) [10225-623](#) [10828058](#) [13100103](#) [28230-439-C](#)
[24563-457](#) [24563-444](#) [20848-601](#) [21101-853](#) [24563-134](#) [24564-431](#) [24827-107](#) [24563-142](#) [24563-157](#) [24563-442](#) [A265HC-5.80EH](#) [24561-331](#) [10225640](#)