



This product, formerly sold by ams AG, and before that optionally by either Applied Sensors GmbH, acam-messelectronic GmbH or Cambridge CMOS Sensors, is now owned and sold by

SciSense

The technical content of this document under ams / Applied Sensors / acam-messelectronic / Cambridge CMOS Sensors is still valid.

Contact information

Headquarters:

SciSense B.V.

High Tech Campus 10

5656 AE Eindhoven

The Netherlands

info@sciosense.com

www.sciosense.com

AS3933

3D Low Frequency Wake-Up Receiver

General Description

The AS3933 is a 3-channel low power ASK receiver that is able to generate a wake-up upon detection of a data signal which uses a LF carrier frequency between 15-150 kHz. The integrated correlator can be used for detection of a programmable 16-bit or 32-bit Manchester wake-up pattern. The device can operate using one, two, or three active channels.

The AS3933 provides a digital RSSI value for each active channel, it supports a programmable data rate and Manchester decoding with clock recovery. The AS3933 offers an internal Clock Generator, which is either derived from a crystal oscillator or the internal RC oscillator. The user can decide to use the external clock generator instead.

The programmable features of AS3933 enable to optimize its settings for achieving a longer distance while retaining a reliable wake-up generation. The sensitivity level of AS3933 can be adjusted in presence of a strong field or in noisy environments.

Antenna tuning is greatly simplified, as the automatic tuning feature ensures perfect matching to the desired carrier frequency.

The device is available in 16-pin TSSOP and 16-LD QFN (4x4mm) packages, and DoW (dice on wafer).

[Ordering Information](#) and [Content Guide](#) appear at end of datasheet.

Key Benefits & Features

The benefits and features of AS3933, 3D Low Frequency Wake-Up Receiver are listed below:

Figure 1:
Added Value of Using AS3933

Benefits	Features
<ul style="list-style-type: none"> Enables low power active tags 	<ul style="list-style-type: none"> 3-channel ASK wake-up receiver
<ul style="list-style-type: none"> Selectable carrier frequency 	<ul style="list-style-type: none"> Carrier frequency range 15 – 150 kHz
<ul style="list-style-type: none"> One, two, or three channel operation 	<ul style="list-style-type: none"> 1-D, 2-D, or 3-D wake-up pattern detection
<ul style="list-style-type: none"> Highly resistant to false wake-ups 	<ul style="list-style-type: none"> 32-bit programmable wake-up pattern
<ul style="list-style-type: none"> Improved immunity to false wake-ups 	<ul style="list-style-type: none"> Supporting doubling of wake-up pattern
<ul style="list-style-type: none"> Allows frequency only detection 	<ul style="list-style-type: none"> Wake-up without pattern detection selectable
<ul style="list-style-type: none"> Improved range with best-in-class sensitivity 	<ul style="list-style-type: none"> Wake-up sensitivity 80µVRMS (typ.)

Benefits	Features
<ul style="list-style-type: none"> Adjustable range 	<ul style="list-style-type: none"> Sensitivity level adjustable
<ul style="list-style-type: none"> Provides tracking of false wake-ups 	<ul style="list-style-type: none"> False wake-up counter
<ul style="list-style-type: none"> Ensures wake-up in a noise environment 	<ul style="list-style-type: none"> Periodical forced wake-up supported (1s – 2h)
<ul style="list-style-type: none"> Extended battery life 	<ul style="list-style-type: none"> Current consumption in 3-channel listening mode 2.3 μA (typ.)
<ul style="list-style-type: none"> Flexible clock configuration 	<ul style="list-style-type: none"> RTC based 32 kHz XTAL, RC-OSC, or external clock
<ul style="list-style-type: none"> Operates from a 3V battery 	<ul style="list-style-type: none"> Operating supply range 2.4V – 3.6V (TA = 25°C)
<ul style="list-style-type: none"> Industrial temperature range 	<ul style="list-style-type: none"> Operation temperature range -40°C to 85°C

Applications

The AS3933, 3D Low Frequency Wake-Up Receiver is ideal for Active RFID tags, Real-time location systems, Operator identification, Access control, and Wireless sensors.

Figure 2:
AS3933 Typical Application Diagram with Crystal Oscillator

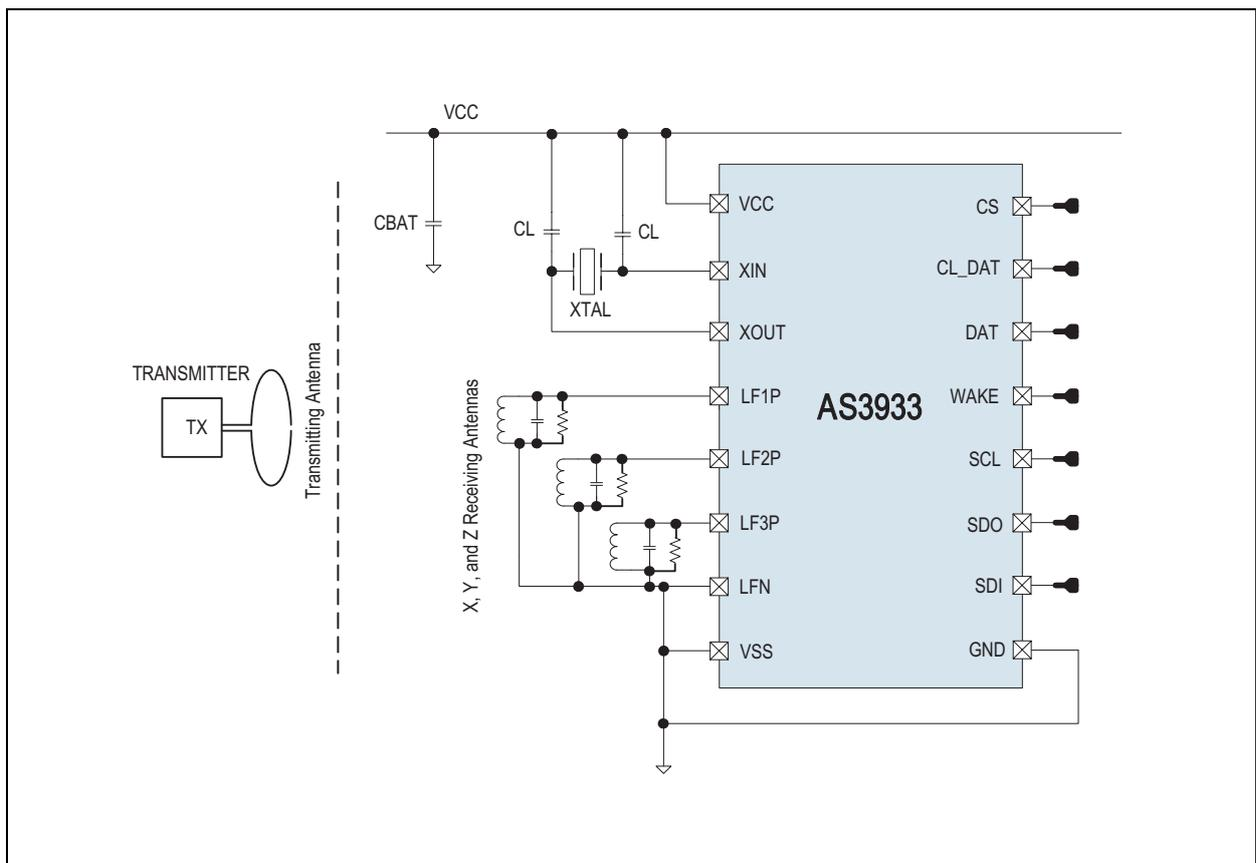

Figure 3:
AS3933 Typical Application Diagram with RC Oscillator

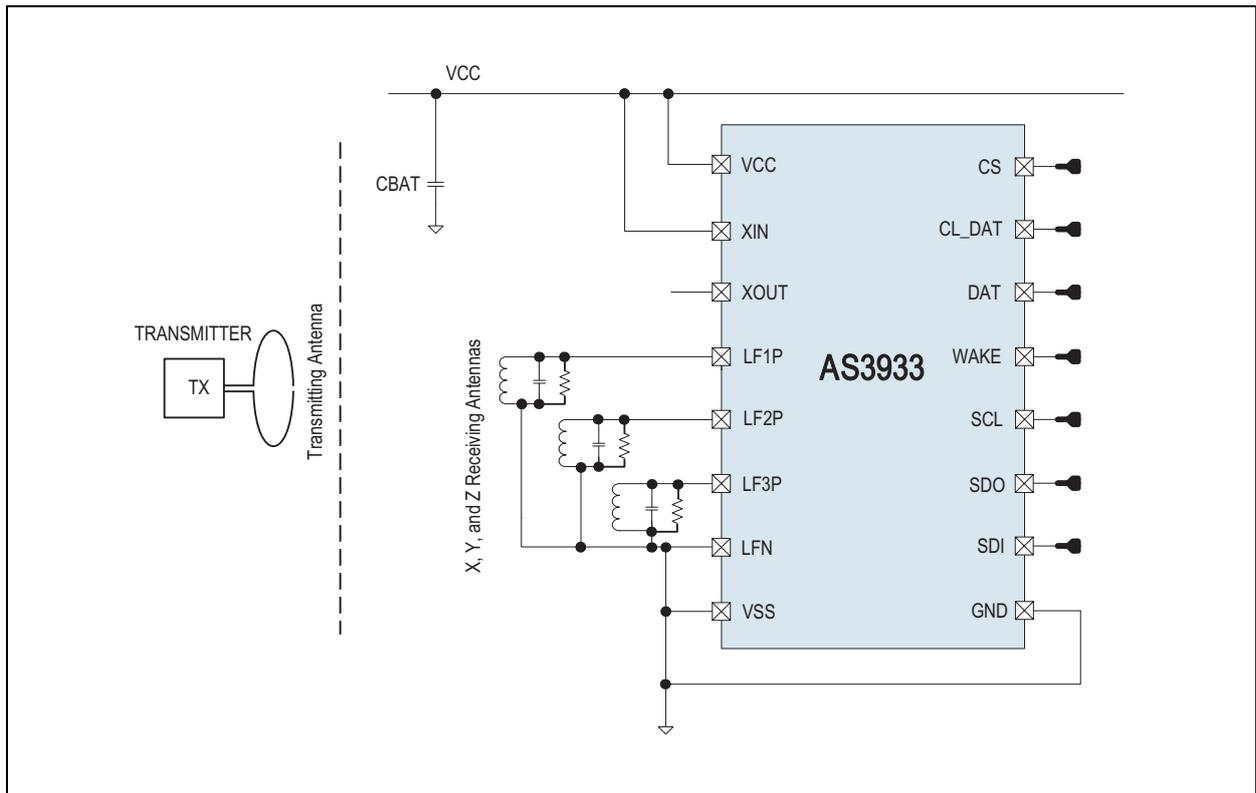
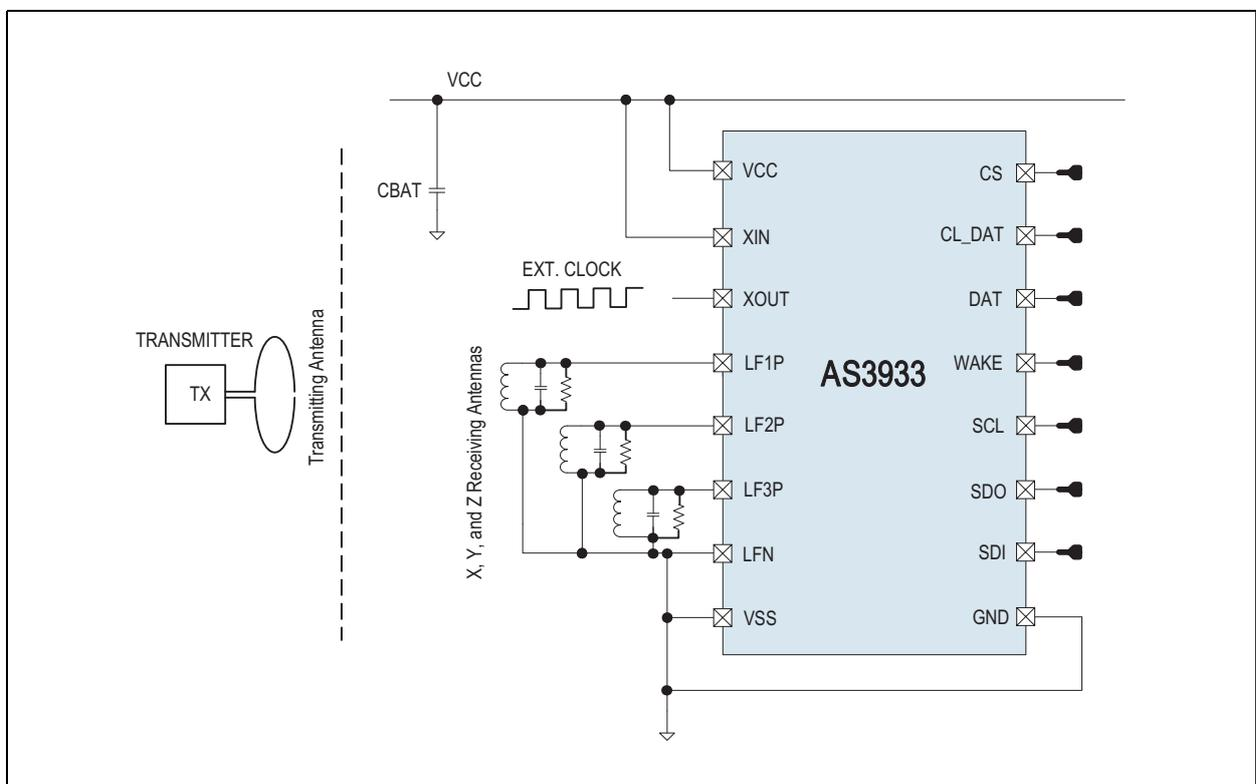

Figure 4:
AS3933 Typical Application Diagram with Clock from External Source



Pin Assignments

TSSOP-16 Package

Figure 5:
TSSOP Pin Assignment (Top View)

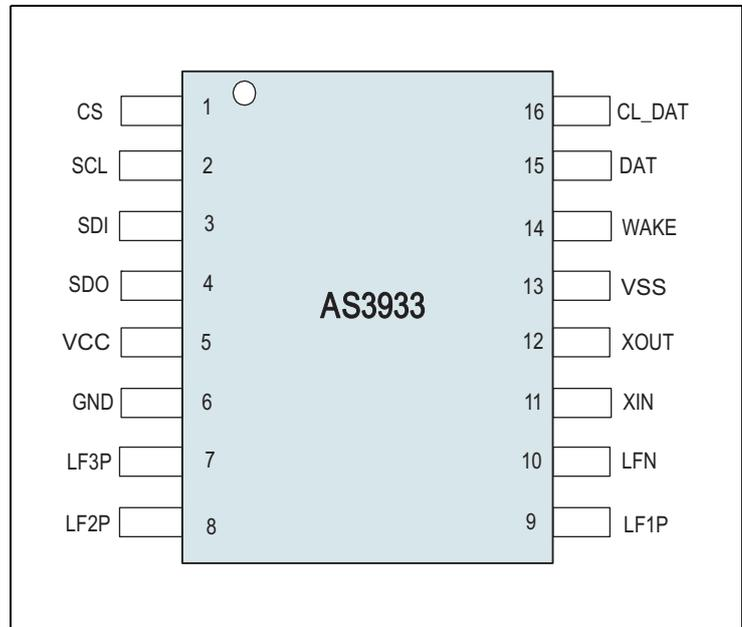

Pin Description

Figure 6:
TSSOP-16 Pin Description

Pin Name	Pin Number	Pin Type	Description
CS	1	Digital input	Chip select
SCL	2		SDI interface clock
SDI	3		SDI data input
SDO	4	Digital output / tristate	SDI data output (tristate when CS is low)
V _{CC}	5	Supply pad	Positive supply voltage
GND	6		Negative supply voltage

Pin Name	Pin Number	Pin Type	Description
LF3P	7	Analog I/O	Input antenna channel three
LF2P	8		Input antenna channel two
LF1P	9		Input antenna channel one
LFN	10		Common ground for antenna one, two and three
XIN	11		Crystal oscillator input
XOUT	12		Crystal oscillator output
V _{SS}	13	Supply pad	Substrate
WAKE	14	Digital output	Wake-up output IRQ
DAT	15		Data output
CL_DAT	16		Manchester recovered clock

QFN-16 Package

Figure 7:
QFN Pin Assignment (Top View)

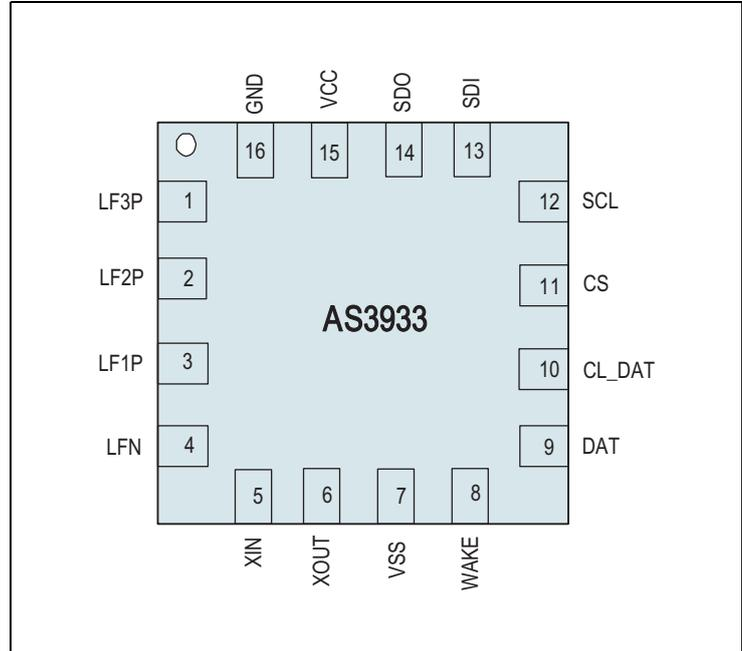

Pin Description

Figure 8:
QFN-16 Pin Description

Pin Name	Pin Number	Pin Type	Description
LF3P	1	Analog I/O	Input antenna channel three
LF2P	2		Input antenna channel two
LF1P	3		Input antenna channel one
LFN	4		Common ground for antenna one, two and three
XIN	5		Crystal oscillator input
XOUT	6		Crystal oscillator output
V _{SS}	7	Supply pad	Substrate
WAKE	8	Digital output	Wake-up output IRQ
DAT	9		Data output
CL_DAT	10		Manchester recovered clock
CS	11	Digital input	Chip select
SCL	12		SDI interface clock
SDI	13		SDI data input
SDO	14	Digital output / tristate	SDI data output (tristate when CS is low)
V _{CC}	15	Supply pad	Positive supply voltage
GND	16		Negative supply voltage

Dice On Wafer

DoW Attributes:

- Wafer Diameter: 8"
- Process: 0.35µm
- Wafer Thickness: 725µm ± 15µm
- Scribe line: 80µm
- Chip Size: 2.070 x 1.700 mm
- Pad Size: 85 x 85 µm

Figure 9:
DoW Pad Assignment

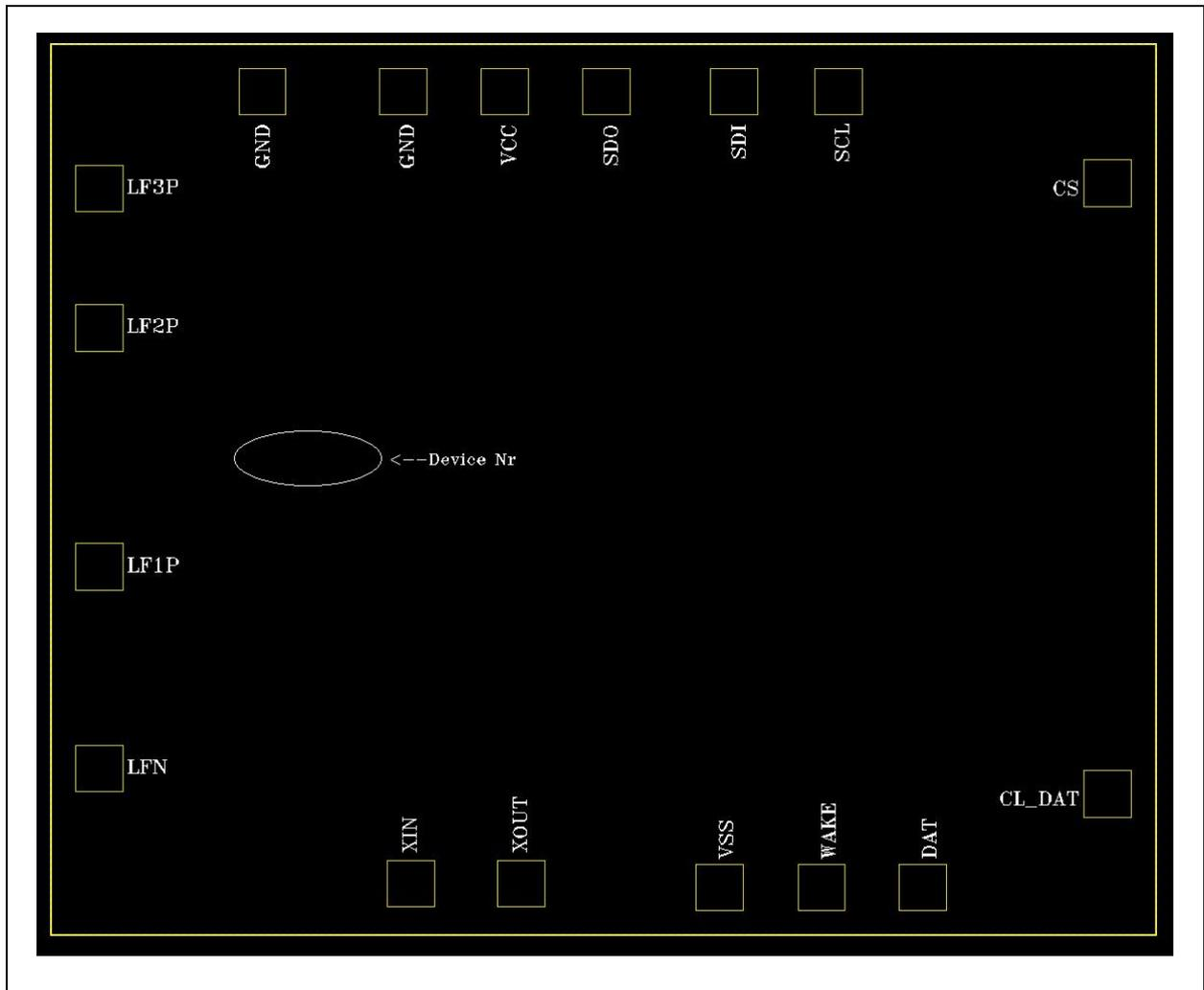

Figure 10:
DoW Pad Description and Position

Position	Pad	Name	Center X (μm)	Center Y (μm)
Upper Side	1	GND	381.5	1532.5
	2	GND	634.5	1532.5
	3	VCC	817.5	1532.5
	4	SDO	1000.5	1532.5
	5	SDI	1230.5	1532.5
	6	SCL	1417.5	1532.5
Right Side	1	CL_DAT	1902.5	257.5
	2	CS	1902.5	1365.5
Bottom Side	1	XIN	648.35	94.5
	2	XOUT	847.5	94.5
	3	VSS	1203.5	87.5
	4	WAKE	1387.5	87.5
	5	DAT	1569.5	87.5
Left Side	1	LFN	87.5	303.5
	2	LF1P	87.5	669.5
	3	LF2P	87.5	1103.5
	4	LF3P	87.5	1356.5

Absolute Maximum Ratings

Stresses beyond those listed in Absolute Maximum Ratings may cause permanent damage to the device. These are stress ratings only. Functional operation of the device at these or any other conditions beyond those indicated in [Operating Conditions](#) is not implied. Exposure to absolute maximum rating conditions for extended periods may affect device reliability.

Figure 11:
Absolute Maximum Ratings

Symbol	Parameter	Min	Max	Unit	Note
Electrical Parameters					
V_{DD}	DC supply voltage	-0.5	5	V	
V_{IN}	Input pin voltage	-0.5	5	V	
I_{SOURCE}	Input current (latch up immunity)	-100	100	mA	Norm: Jedec 78
Electrostatic Discharge					
ESD	Electrostatic discharge	± 2		kV	Norm: MIL 883 E method 3015 (HBM)
Continuous Power Dissipation					
P_t	Total power dissipation (all supplies and outputs)		0.07	mW	
Temperature Ranges and Storage Conditions					
T_{strg}	Storage temperature	-65	150	°C	
T_{body}	Package body temperature		260	°C	Norm: IPC/JEDEC J-STD-020 <i>The reflow peak soldering temperature (body temperature) is specified according IPC/JEDEC J-STD-020 "Moisture/Reflow Sensitivity Classification for Non-hermetic Solid State Surface Mount Devices".</i>
RH_{NC}	Relative Humidity (non-condensing)	5	85	%	
MSL	Moisture Sensitivity Level	3			Represents a maximum floor life time of 168h

Electrical Characteristics

Figure 12:
Operating Conditions

Symbol	Parameter	Conditions	Min	Typ	Max	Unit
V_{DD}	Positive supply voltage		2.4	3	3.6	V
V_{SS}	Negative supply voltage		0		0	V
T_{AMB}	Ambient temperature		-40		85	°C

Figure 13:
DC/AC Characteristics for Digital Inputs and Outputs

Symbol	Parameter	Conditions	Min	Typ	Max	Unit
CMOS Input						
V_{IH}	High level input voltage		0.6* V_{DD}	0.7* V_{DD}	0.8* V_{DD}	V
V_{IL}	Low level input voltage		0.12* V_{DD}	0.2* V_{DD}	0.3* V_{DD}	V
I_{LEAK}	Input leakage current				100	nA
CMOS Output						
V_{OH}	High level output voltage	With a load current of 1mA	$V_{DD} - 0.4$			V
V_{OL}	Low level output voltage	With a load current of 1mA			$V_{SS} + 0.4$	V
C_L	Capacitive load	For a clock frequency of 1 MHz			400	pF
Tristate CMOS Output						
V_{OH}	High level output voltage	With a load current of 1mA	$V_{DD} - 0.4$			V
V_{OL}	Low level output voltage	With a load current of 1mA			$V_{SS} + 0.4$	V
I_{OZ}	Tristate leakage current	To V_{DD} and V_{SS}			100	nA

Figure 14:
Electrical System Specifications

Symbol	Parameter	Conditions	Min	Typ	Max	Unit
Input Characteristics						
R_{IN}	AC Input Impedance at 125kHz	In case no antenna damper is set ($R1<4>=0$)		2		MΩ
F1max	Maximum Input Frequency Band1			150		kHz
F1min	Minimum Input Frequency Band1			95		kHz
F2max	Maximum Input Frequency Band2			95		kHz
F2min	Minimum Input Frequency Band2			65		kHz
F3max	Maximum Input Frequency Band3			65		kHz
F3min	Minimum Input Frequency Band3			40		kHz
F4max	Maximum Input Frequency Band4			40		kHz
F4min	Minimum Input Frequency Band4			23		kHz
F5max	Maximum Input Frequency Band5			23		kHz
F5min	Minimum Input Frequency Band5			15		kHz
Current Consumption						
I1CHRC	Current Consumption in standard listening mode with one active channel and RC-oscillator as Clock Generator			3.1		μA
I2CHRC	Current Consumption in standard listening mode with two active channels and RC-oscillator as Clock Generator			4.6		μA

Symbol	Parameter	Conditions	Min	Typ	Max	Unit
I3CHRC	Current Consumption in standard listening mode with three active channels and RC-oscillator as Clock Generator			6.1		μA
I3CHSCRC	Current Consumption in scanning mode with three active channels and RC-oscillator as Clock Generator			3.1		μA
I3CHOORC	Current Consumption in ON/OFF mode with three active channels and RC-oscillator as Clock Generator	11% Duty Cycle		2.3		μA
		50% Duty Cycle		3.8		
I3CHXT	Current Consumption in standard listening mode with three active channels and crystal oscillator as Clock Generator			6.5	8.9	μA
IDATA	Current Consumption in Preamble detection / Pattern correlation / Data receiving mode (RC-oscillator)	With 125 kHz carrier frequency and 1 kbps data-rate. No load on the output pins.		8.3	12	μA
IBOOST	Additional current consumption per channel if gain boost enabled			150		nA
Input Sensitivity						
SENS1	Input Sensitivity on all channels in the Band1	With 125 kHz carrier frequency, chip in default mode, 4 half bits burst + 4 symbols preamble and single preamble detection		100		μVrms
SENS1B	Input Sensitivity on all channels in the Band1 with 3dB gain boost	With 125 kHz carrier frequency, chip in default mode, 4 half bits burst + 4 symbols preamble and single preamble detection		80		μVrms
SENS2	Input Sensitivity on all channels in the Band2	With 90 kHz carrier frequency, chip in default mode, 4 half bits burst + 4 symbols preamble and single preamble detection		100		μVrms

Symbol	Parameter	Conditions	Min	Typ	Max	Unit
SENS2B	Input Sensitivity on all channels in the Band2 with 3dB gain boost	With 90 kHz carrier frequency, chip in default mode, 4 half bits burst + 4 symbols preamble and single preamble detection		80		μVrms
SENS3	Input Sensitivity on all channels in the Band3	With 60 kHz carrier frequency, chip in default mode, 4 half bits burst + 4 symbols preamble and single preamble detection		100		μVrms
SENS3B	Input Sensitivity on all channels in the Band3 with 3dB gain boost	With 60 kHz carrier frequency, chip in default mode, 4 half bits burst + 4 symbols preamble and single preamble detection		80		μVrms
SENS4B	Input Sensitivity on all channels in the Band4 with 3dB gain boost	With 30 kHz carrier frequency, chip in default mode, 4 half bits burst + 4 symbols preamble and single preamble detection		80		μVrms
SENS5B	Input Sensitivity on all channels in the Band5 with 3dB gain boost	With 18 kHz carrier frequency, chip in default mode, 4 half bits burst + 4 symbols preamble and single preamble detection		80		μVrms
Channel Settling Time						
TSAMP	Amplifier settling time			250		μs
Crystal Oscillator						
FXTAL	Frequency	Crystal dependent	25	32.768	45	kHz
TXTAL	Start-up Time				1	s
IXTAL	Current consumption			300		nA
External Clock Source						
IEXTCL	Current consumption			0.8		μA
FEXTCL	Frequency		25		45	kHz

Symbol	Parameter	Conditions	Min	Typ	Max	Unit
RC Oscillator						
FRCNCAL	Frequency	If no calibration is performed	25	32.768	45	kHz
FRCCAL32		If calibration with 32.768 kHz reference signal is performed	31	32.768	34.5	
FRCCALMAX		Maximum achievable frequency after calibration		23.75		
FRCCALMIN		Minimum achievable frequency after calibration		45		
TRC	Start-up time	From RC enable (R1<0> = 0)			1	s
TCALRC	Calibration time		65			Periods of reference clock
IRC	Current consumption			650		nA
LC Oscillator						
FLCO _{MIN}	Minimum Frequency	L=47mH (Premo: SDTR1103-0108+), C=2.3nF		15		kHz
FLCO _{MAX}	Maximum Frequency	L=7.2mH (Premo: SDTR1103-0720+), C=1nF		150		kHz
RPAR _{MIN}	Minimum Eq. Parallel			10		kΩ
Tuning Caps						
LF1Ptuning	Capacitance	Maximum internal capacitance (in step of 1pF) on LF1P		31		pF
LF2Ptuning		Maximum internal capacitance (in step of 1pF) on LF2P		31		pF
LF3Ptuning		Maximum internal capacitance (in step of 1pF) on LF3P		31		pF

Typical Operating Characteristics

Figure 15:
Sensitivity vs Voltage and Temperature

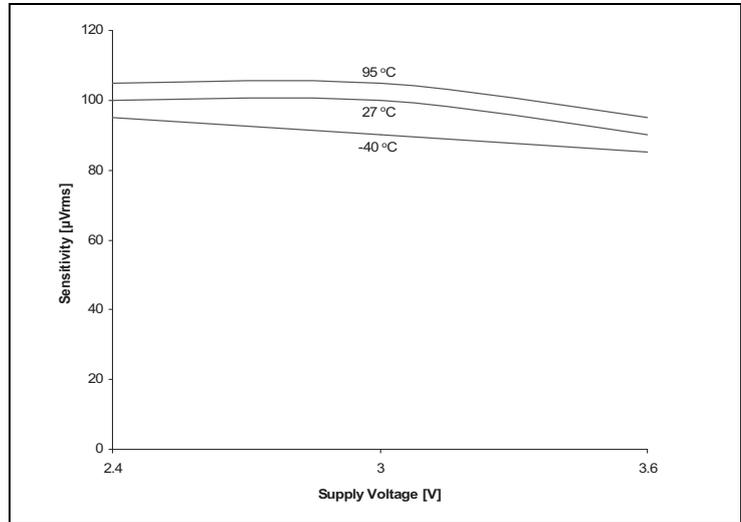

Figure 16:
Sensitivity vs RSSI

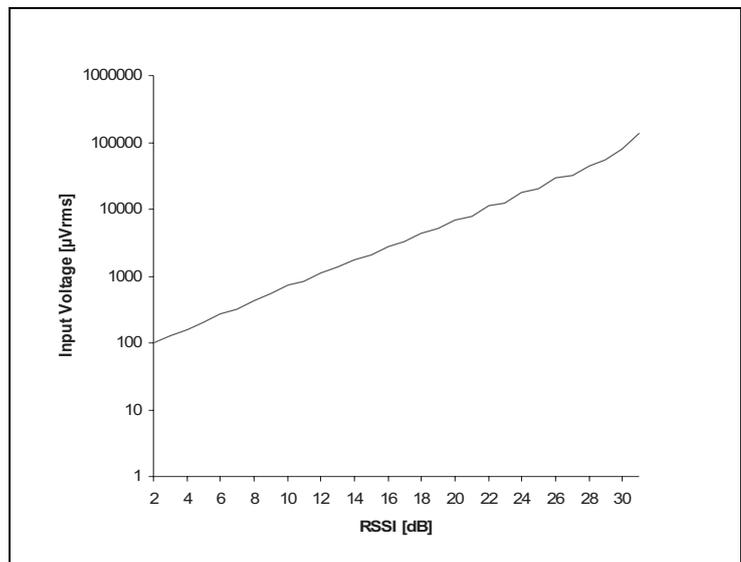

Figure 17:
RC-Oscillator Frequency vs Voltage (Calibr.)

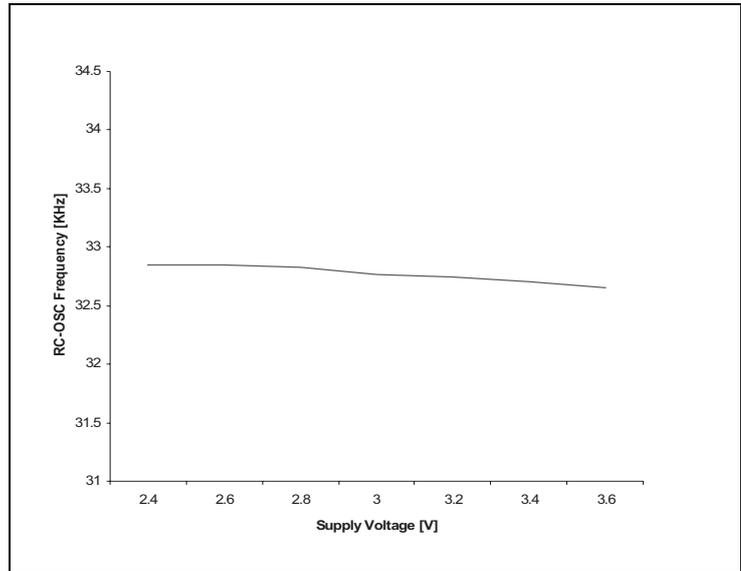
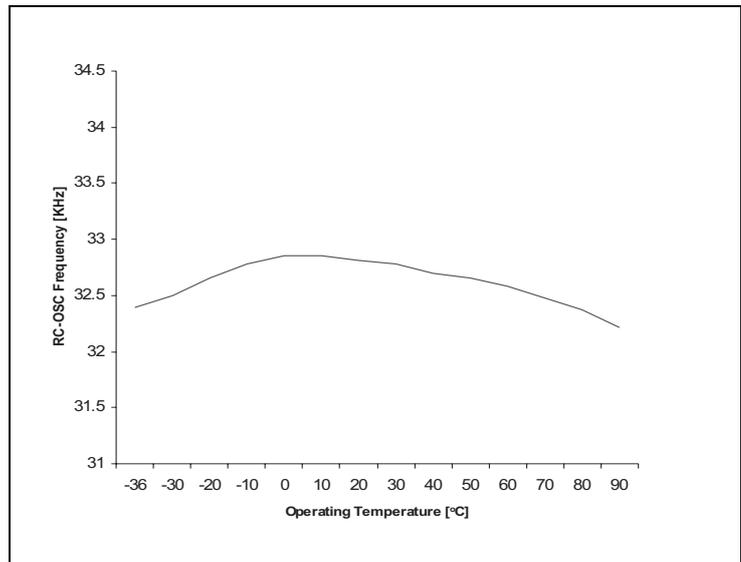

Figure 18:
RC-Oscillator Frequency vs Temperature (Calibr.)



Detailed Description

The AS3933 is a three-dimensional low power low-frequency wake-up receiver. The AS3933 is capable of detecting the presence of an inductive coupled carrier and can extract the envelope of the ON-OFF-Keying (OOK) modulated carrier. In case the carrier is Manchester coded, the clock can be recovered from the received signal and the data can be correlated with a programmed pattern. If the detected pattern corresponds to the stored one, a wake-up signal (IRQ) is risen up. The pattern correlation can be disabled; in this case the wake-up detection is based only on the frequency detection.

The AS3933 is made up of three independent receiving channels, one envelop detector, one data correlator, one Manchester decoder, 19 programmable registers with the main logic and a Clock Generator.

The digital logic can be accessed by an SPI. The Clock Generator can be based on a crystal oscillator, or an internal RC-oscillator or an external clock. In case the RC-oscillator is used to improve its accuracy, a calibration can be performed.

The internal LC-oscillator can deliver the antenna's oscillation frequency for each channel and the internal tuning capacitor bank can provide fine tuning.

The Internal RC-oscillator can be calibrated either over SPI or using the internal algorithm based on the antenna resonance frequency.

Figure 19:
Block Diagram of LF Wake-Up Receiver AS3933

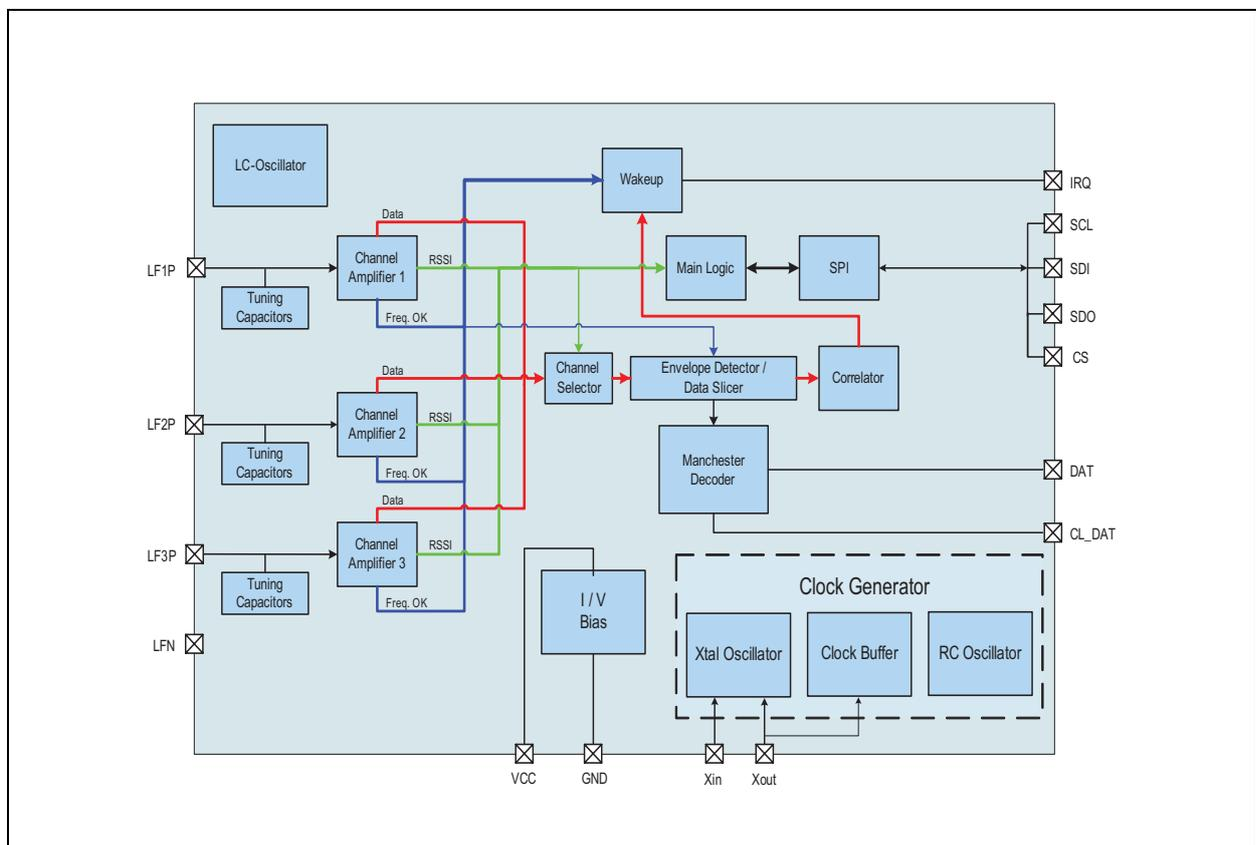

AS3933 needs the following external components:

- Power supply capacitor - CBAT - 100 nF.
- 32.768 kHz crystal with its two pulling capacitors - XTAL and CL - (it is possible to omit these components if the internal RC oscillator is used instead of the crystal oscillator).
- One, two, or three LC resonators according to the number of used channels.

In case the internal RC-oscillator is used (no crystal oscillator is mounted), the pin XIN has to be connected to the supply, while pin XOUT should stay floating. Application diagrams with and without crystal are shown in [Figure 2](#), [Figure 3](#) and [Figure 4](#).

Operating Modes

The diagram in [Figure 20](#) shows how the AS3933 operates.

Figure 20:
Operating Modes Flow Chart

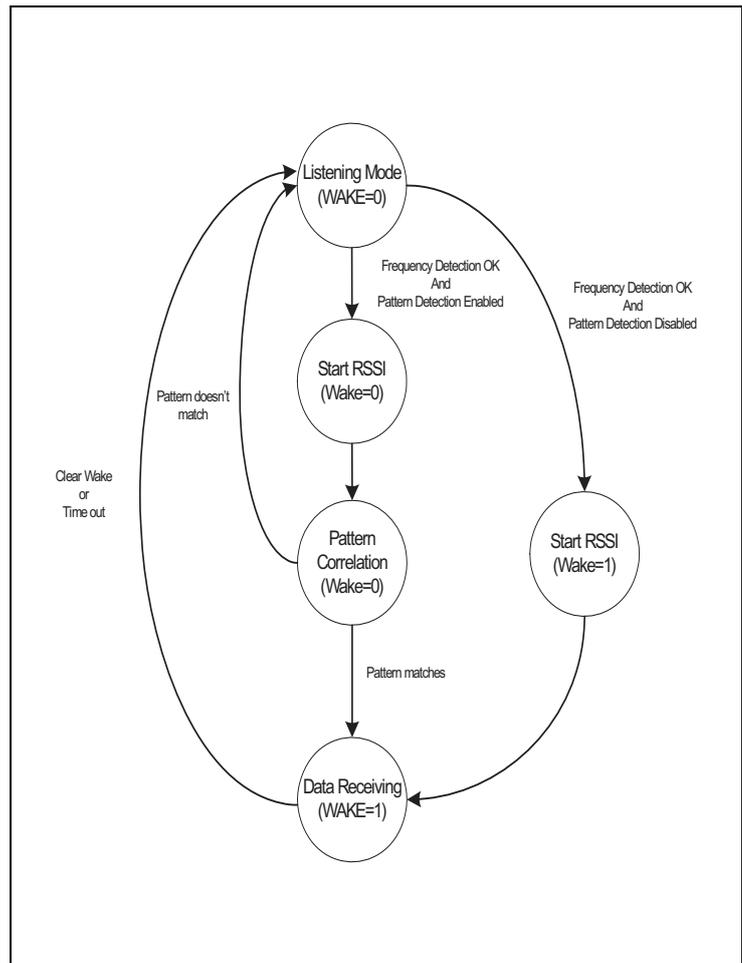

Listening Mode

In listening mode, the chip is active and looks continuously for the presence of the carrier on the input of all active channels. In this mode, only the active channel amplifiers and the Clock Generator are running. In case the carrier is detected, then the RSSI measurements get started on all three channels and the result is stored in the memory.

If the three dimensional detection is not required, then it is possible to deactivate one or more channels. In case only two channels are required, then the deactivated channel must be the number two; while in case only one channel is needed, then the active channel must be the number one.

Inside the listening mode, it is possible to distinguish the following three low power sub modes:

Standard Listening Mode. All channels are active at the same time.

Scanning Mode (Low Power Mode 1). In this sub-mode, a time slot $T=1\text{ms}$ is defined and in each time slot only one channel can be active. As shown in [Figure 21](#) when a certain time slot is over, the current active channel is switched OFF and the next channel becomes active and so on. If, for example all three channels are enabled, in the first time slot the only active channel is the number one. When the first time slot is over, the channel one is switched OFF and the channel three becomes active. During the third time slot, the channel two is active while the other two are OFF. This channel rotation starts back from the channel one and goes on until the presence of the carrier is detected by any channel. The Scanning mode (channel rotation) is managed internally by the AS3933 and doesn't need any activity from the host system (MCU). As soon as one channel detects the frequency, all three channels become immediately active at the same time. The AS3933 can perform a simultaneous multidirectional evaluation (on all three channels) of the field and evaluate which channel has the strongest RSSI. The channel with the highest RSSI will be put through to the demodulator. In this way it is possible to perform multidirectional monitoring of the field with a current consumption of a single channel, keeping the sensitivity as good as if all channels are active at the same time.

Figure 21:
Scanning Mode

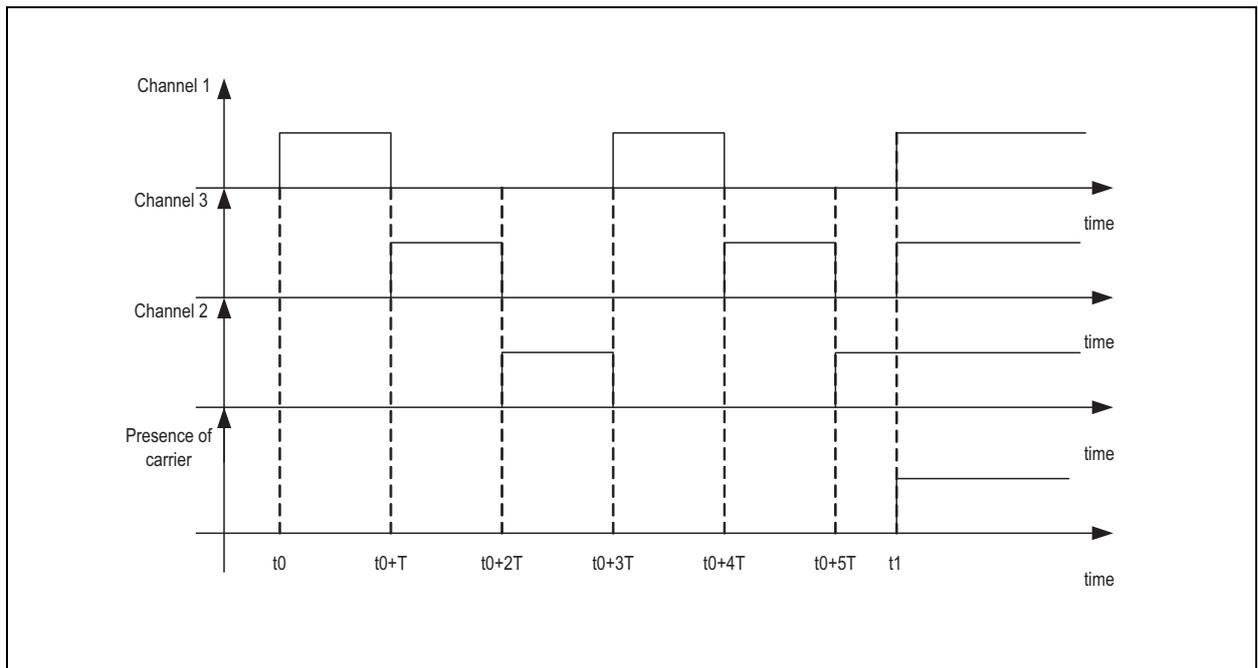

ON/OFF Mode (Low Power Mode 2). In this low power sub-mode the chip sets the receiving channels in polling mode; all active channels are on at the same time only for a certain time T (where T is 1 ms). The OFF-time can be defined with the bits $R4\langle 7:6 \rangle$. If, for example, $R4\langle 7:6 \rangle = 11$ (see Figure 25) the active channels will be 1ms ON and 8ms OFF.

Figure 22:
ON/OFF Mode

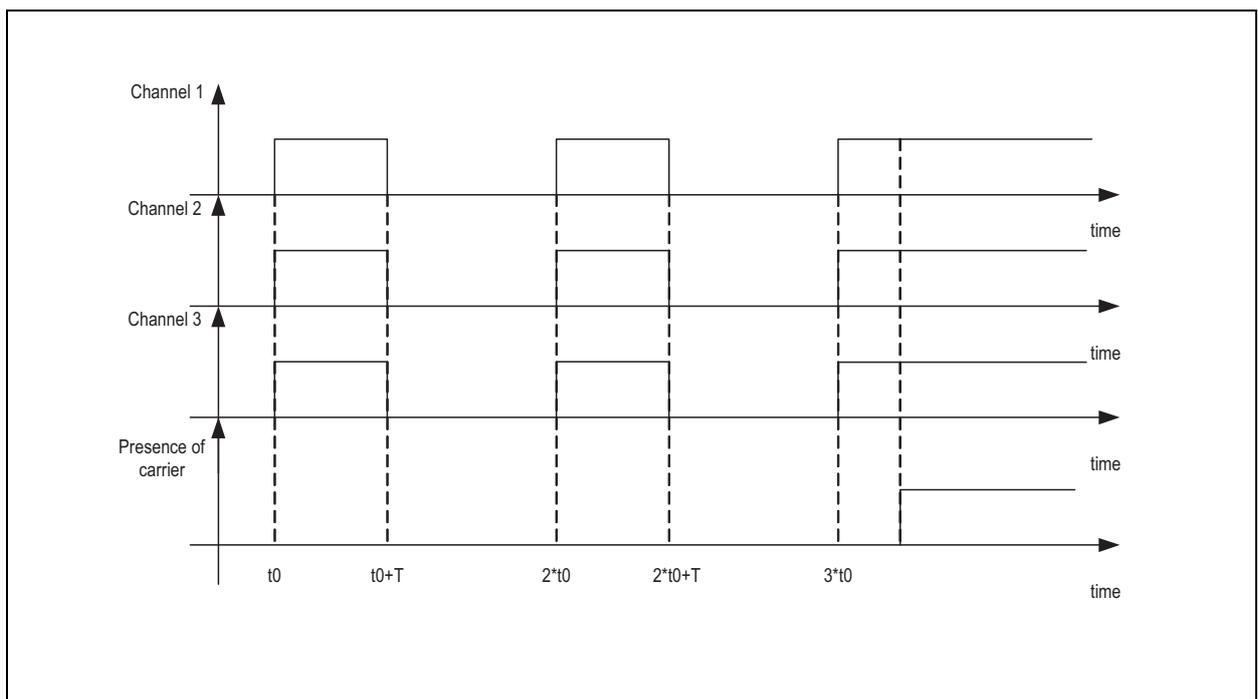

Artificial Wake-Up

For each of these sub modes it is possible to enable a further feature called Artificial Wake-up. The Artificial Wake-up is a counter based on the used Clock Generator. Three bits define a time window (see [R8<2:0>](#)). If no activity is seen within this time window, the chip will produce an interrupt on the WAKE pin that lasts 128 μ s. With this interrupt the microcontroller (μ C) can get feedback on the surrounding environment (e.g. read the false wake-up register [R13<7:0>](#)) and/or take actions in order to change the setup.

Preamble Detection / Pattern Correlation

The chip can go in to this mode after detecting a LF carrier only if the data correlation is enabled ([R1<1>](#)=1). The correlator searches first for preamble bits and then for data pattern. The paragraph [Wake-Up Protocol: Pattern Detection Enabled](#) describes how the protocol can be implemented. Should the pattern correlation be disabled ([R1<1>](#)=0), the AS3933 goes directly in Data receiving mode (see paragraph [Data Receiving](#)).

If the received pattern matches, then the wake-up interrupt is displayed on the WAKE output (Wake goes high) and the chip goes in Data receiving mode. If the pattern fails, then the internal wake-up (on all active channels) is terminated and no interrupt is produced.

Having per default DAT_MASK disabled ([R0<6>](#)=0), the DAT pin shows the entire demodulated incoming signal (carrier burst+preamble+pattern+data).

If DAT_MASK is enabled ([R0<6>](#)=1), the data will be displayed only after the generation of the WAKEUP interrupt.

Note(s): It is important to note that the Manchester decoder must be enabled ([R1<3>](#)=1) for this feature.

Data Receiving

After a successful wake-up the chip enters the data receiving mode. In this mode the chip can be retained a normal OOK receiver. The data is provided on the DAT pin and in case the Manchester decoder is enabled (see [R1<3>](#)), the recovered clock is present on the CL_DAT. It is possible to set the chip back to listening mode either with a direct command CLEAR_WAKE (see [Figure 29](#)) or by using the timeout feature. This feature automatically sets the chip back to listening mode after a certain time defined by the bits [R7<7:5>](#).

System and Block Specification

Register Overview

Figure 23:
Register Overview

	7	6	5	4	3	2	1	0
R0	PATT32	DAT_MASK	ON_OFF	MUX_123	EN_A2	EN_A3	EN_A1	
R1	ABS_HY	AGC_TLM	AGC_UD	ATT_ON	EN_MANCH	EN_PAT2	EN_WPAT	EN_XTAL
R2	S_ABS	EN_EXT_CLK	G_BOOST	Reserved	DISPLAY_CLK		S_WU1	
R3	HY_20m	HY_POS	FS_SLC			FS_ENV		
R4	T_OFF		R_VAL		GR			
R5	PATT2B							
R6	PATT1B							
R7	T_OUT			T_HBIT				
R8	BAND_SEL					T_AUTO		
R9	BLOCK_AGC	Reserved						
R10	n.a.			RSSI1				
R11	n.a.			RSSI2				
R12	n.a.			RSSI3				
R13	F_WAKE							
R14	RC_CAL_OK	RC_CAL_KO	RC_OSC_TAPS					
R15	n.a.			LC_OSC_OK	LC_OSC_KO	n.a.		
R16	CLOCK_G EN_DIS	n.a.	RC_OSC_MIN	RC_OSC_MAX	n.a.	LC_OSC_MUX		
R17	n.a.			CAP_CH1				
R18	n.a.			CAP_CH2				
R19	n.a.			CAP_CH3				

Register Description and Default Values

Figure 24:
Default Values of Registers

Register	Name	Type	Default Value	Description
R0<7>	PAT32	R/W	0	Pattern extended to 32 bits (PAT32=0 16 bits, PAT32=1 32bits)
R0<6>	DAT_MASK	R/W	0	Masks data on DAT pin before wake-up (DAT_MASK = 0 → data not masked; DAT_MASK = 1 → data masked)
R0<5>	ON_OFF	R/W	0	ON/OFF operation mode. (Duty-cycle defined in the register R4<7:6>
R0<4>	MUX_123	R/W	0	Scan mode enable
R0<3>	EN_A2	R/W	1	Channel 2 enable
R0<2>	EN_A3	R/W	1	Channel 3 enable
R0<1>	EN_A1	R/W	1	Channel 1 enable
R0<0>	Reserved		0	Reserved
R1<7>	ABS_HY	R/W	0	Enable Data slicer absolute reference
R1<6>	AGC_TLIM	R/W	0	AGC acting only on the first carrier burst
R1<5>	AGC_UD	R/W	1	AGC operating in both direction (up-down)
R1<4>	ATT_ON	R/W	0	Antenna damper enable
R1<3>	EN_MANC H	R/W	0	Manchester decoder enable
R1<2>	EN_PAT2	R/W	0	Double wake-up pattern correlation
R1<1>	EN_WPAT	R/W	1	Correlator enable
R1<0>	EN_XTAL	R/W	1	Crystal oscillator enable
R2<7>	S_ABSH	R/W	0	Data slicer absolute threshold reduction
R2<6>	EN_EXT_C LK	R/W	0	Enables external clock generator
R2<5>	G_BOOST	R/W	0	3dB Amplifier Gain Boost (G_BOOST=1)
R2<5>	Reserved		0	Reserved
R2<3:2>	DISPLAY_ CLK	R/W	00	Set to 11 in case the clock generator's frequency is shown on pin CL_DAT.
R2<1:0>	S_WU1	R/W	00	Tolerance setting for the stage wake-up (see Figure 37)

Register	Name	Type	Default Value	Description	
R3<7>	HY_20m	R/W	0	Data slicer hysteresis if HY_20m = 0 then comparator hysteresis = 40mV if HY_20m = 1 then comparator hysteresis = 20mV	
R3<6>	HY_POS	R/W	0	Data slicer hysteresis only on positive edges (HY_POS=0, hysteresis on both edges, HY_POS=1, hysteresis only on positive edges)	
R3<5:3>	FS_SCL	R/W	100	Data slicer time constant (see Figure 45)	
R3<2:0>	FS_ENV	R/W	000	Envelop detector time constant (see Figure 44)	
R4<7:6>	T_OFF	R/W	00	OFF time in ON/OFF operation mode	
				T_OFF=00	1ms
				T_OFF=01	2ms
				T_OFF=10	4ms
				T_OFF=11	8ms
R4<5:4>	D_RES	R/W	01	Antenna damping resistor (see Figure 40)	
R4<3:0>	GR	R/W	0000	Gain reduction (see Figure 39)	
R5<7:0>	TS2	R/W	01101001	2nd Byte of wake-up pattern	
R6<7:0>	TS1	R/W	10010110	1st Byte of wake-up pattern	
R7<7:5>	T_OUT	R/W	000	Automatic time-out (see Figure 49)	
R7<4:0>	T_HBIT	R/W	01011	Bit rate definition (see Figure 48)	
R8<7:5>	BAND_SEL	R/W	000	Band selection (see Figure 36)	
R8<2:0>	T_AUTO	R/W	000	Artificial wake-up	
				T_AUTO=000	No artificial wake-up
				T_AUTO=001	1 sec
				T_AUTO=010	5 sec
				T_AUTO=011	20 sec
				T_AUTO=100	2 min
				T_AUTO=101	15min
				T_AUTO=110	1 hour
			T_AUTO=111	2 hour	
R9<7>	BLOCK_A GC	R/W	0	Disables AGC	
R9<6:0>			000000	Reserved	

Register	Name	Type	Default Value	Description
R10<4:0>	RSSI1	R		RSSI channel 1
R11<4:0>	RSSI2	R		RSSI channel 2
R12<4:0>	RSSI3	R		RSSI channel 3
R13<7:0>	F_WAK	R		False wake-up register
R14<7>	RC_CAL_O K	R		Successful RC calibration
R14<6>	RC_CAL_K O	R		Unsuccessful RC calibration
R14<5:0>	RC_OSC_T APS	R		RC-Oscillator taps setting
R15<4>	LC_OSC_O K	R		LC-Oscillator working
R15<3>	LC_OSC_K O	R		LC-Oscillator not working
R16<7>	CLOCK_GE N_DIS	R/W	0	The Clock Generator output signal displayed on CL_DAT pin
R16<5>	RC_OSC_ MIN	R/W	0	Sets the RC-oscillator to minimum frequency
R16<4>	RC_OSC_ MAX	R/W	0	Sets the RC-oscillator to maximum frequency
R16<2>	LC_OSC_ MUX3	R/W	0	Displays the resonance frequency of LF3P on DAT pin
R16<1>	LC_OSC_ MUX2	R/W	0	Displays the resonance frequency of LF2P on DAT pin
R16<0>	LC_OSC_ MUX1	R/W	0	Displays the resonance frequency of LF1P on DAT pin
R17<4:0>	CAPS_CH1	R/W	00000	Capacitor banks on the channel1
R18<4:0>	CAPS_CH1	R/W	00000	Capacitor banks on the channel2
R19<4:0>	CAPS_CH1	R/W	00000	Capacitor banks on the channel3

Serial Peripheral Interface (SPI)

This 4-wire interface is used by the Microcontroller (μC) to program the AS3933. The maximum clock operation frequency of the SPI is 6MHz.

Figure 25:
Serial Peripheral Interface (SPI) Pins

Name	Signal	Signal Level	Description
CS	Digital Input	CMOS	Chip Select
SIN	Digital Input	CMOS	Serial Data input for writing registers, data to transmit and/or writing addresses to select readable register
SOUT	Digital Output	CMOS	Serial Data output for received data or read value of selected registers
SCLK	Digital Input	CMOS	Clock for serial data read and write

Note(s): SDO is set to tristate if CS is low. In this way more than one device can communicate on the same SDO bus.

SDI Command Structure. To program the SPI the CS signal has to go high. A SPI command is made up by a two bytes serial command and the data is sampled on the falling edge of SCLK. The [Figure 26](#) shows how the command looks like, from the MSB (B15) to LSB (B0). The command stream has to be sent to the SPI from the MSB (B15) to the LSB (B0).

Figure 26:
SDI Command Structure

Mode		Register Address / Direct Command						Register Data						
B15	B14	B13	B12	B11	B10	B9	B8	B7	B6	B5	B3	B2	B1	B0

The first two bits (B15 and B14) define the operating mode. There are three modes available (write, read, direct command) plus one spare (not used), as shown in [Figure 27](#).

Figure 27:
SDI Command Structure

B15	B14	Mode
0	0	WRITE
0	1	READ
1	0	NOT ALLOWED
1	1	DIRECT COMMAND

In case a write or read command happens the next 6 bits (B13 to B8) define the register address which has to be written respectively read, as shown in [Figure 28](#).

Figure 28:
SDI Command Structure

B13	B12	B11	B10	B9	B8	Read/Write Register
0	0	0	0	0	0	R0
0	0	0	0	0	1	R1
0	0	0	0	1	0	R2
0	0	0	0	1	1	R3
0	0	0	1	0	0	R4
0	0	0	1	0	1	R5
0	0	0	1	1	0	R6
0	0	0	1	1	1	R7
0	0	1	0	0	0	R8
0	0	1	0	0	1	R9
0	0	1	0	1	0	R10
0	0	1	0	1	1	R11
0	0	1	1	0	0	R12
0	0	1	1	0	1	R13
0	0	1	1	1	0	R14
0	0	1	1	1	1	R15
0	1	0	0	0	0	R16
0	1	0	0	0	1	R17

B13	B12	B11	B10	B9	B8	Read/Write Register
0	1	0	0	1	0	R18
0	1	0	0	1	1	R19

The last 8 bits are the data that has to be written respectively read. A CS toggle high-low-high terminates the command mode.

If a direct command is sent (B15-B14=11) the bits from B13 to B8 defines the direct command while the last 8 bits are omitted. [Figure 29](#) shows all possible direct commands:

Figure 29:
List of Direct Commands

COMMAND_MODE	B13	B12	B11	B10	B9	B8
clear_wake	0	0	0	0	0	0
reset_RSSI	0	0	0	0	0	1
trim_osc	0	0	0	0	1	0
clear_false	0	0	0	0	1	1
preset_default	0	0	0	1	0	0
Calib_RCO_LC	0	0	0	1	0	1

All direct commands are explained below:

- clear_wake: clears the wake state of the chip. In case the chip has woken up (WAKE pin is high) the chip is set back to listening mode.
- reset_RSSI: resets the RSSI measurement.
- Calib_RCosc: starts the trimming procedure of the internal RC oscillator ([see page 29](#)).
- clear_false: resets the false wake-up register (R13<7:0>=00).
- preset_default: sets all register in the default mode, as shown in [Figure 24](#).
- Calib_RCO_LC: calibration of the RC-oscillator with the external LC tank ([see page 31](#)).

Writing of Data to Addressable Registers (WRITE Mode). The SPI is sampled at the falling edge of SCLK (as shown in the following diagrams).

A CS toggling high-low-high indicates the end of the WRITE command after register has been written. The following example shows a write command.

Figure 30:
Writing of a Single Byte (Falling Edge Sampling)

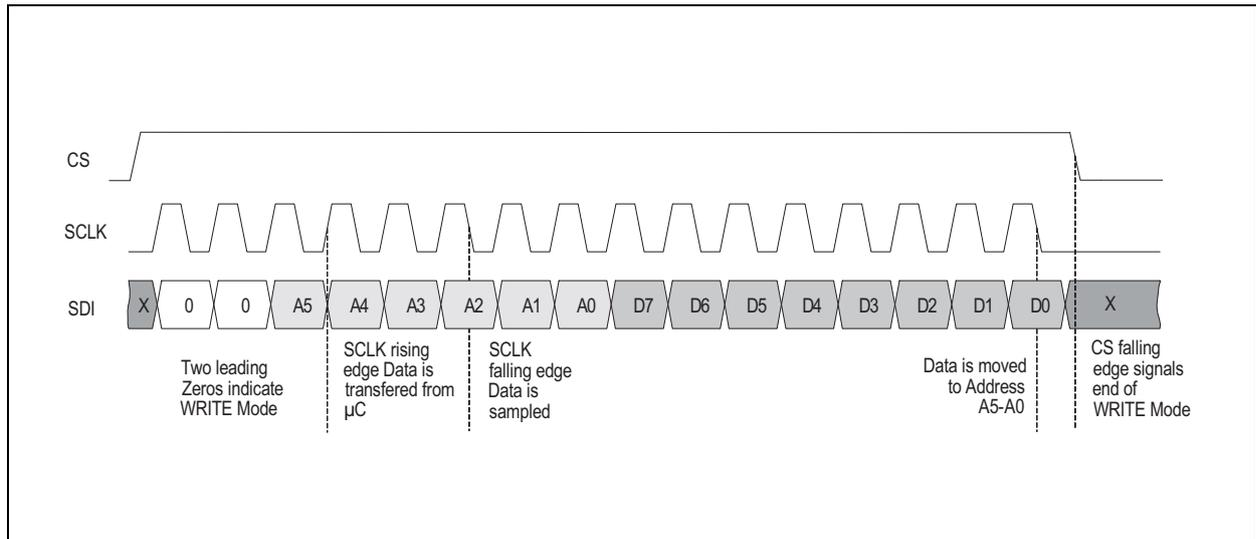
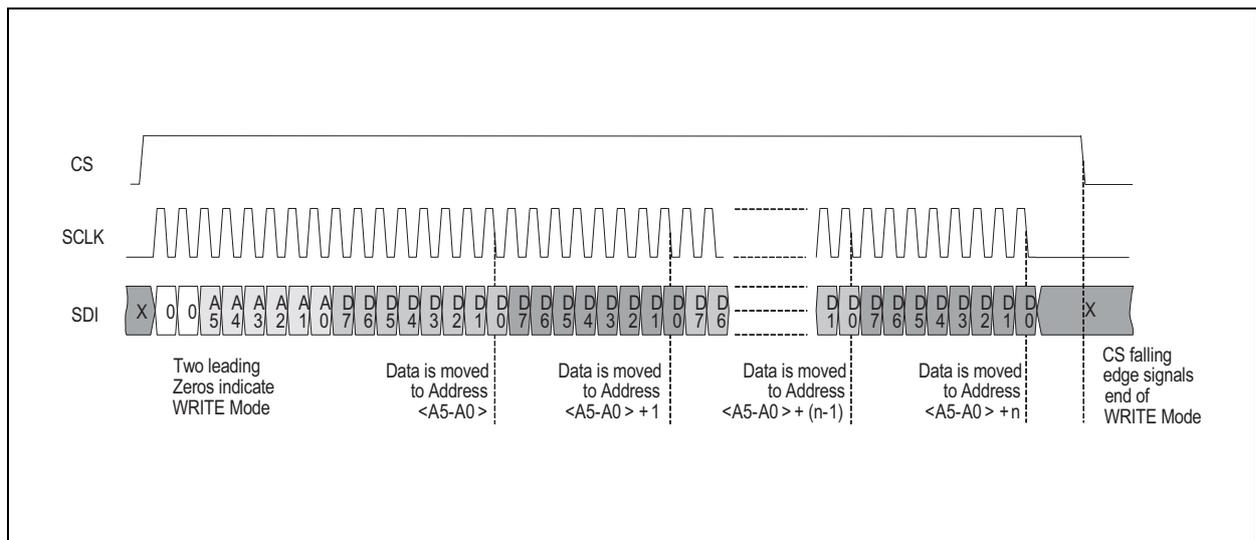

Figure 31:
Writing of Register Data with Auto-Incrementing Address



Reading of Data from Addressable Registers (READ Mode).

Once the address has been sent through SPI, the data can be fed through the SDO pin out to the microcontroller.

A CS LOW toggling high-low-high has to be performed after finishing the read mode session, in order to indicate the end of the READ command and prepare the Interface to the next command control Byte.

To transfer bytes from consecutive addresses, SPI master has to keep the CS signal high and the SCLK clock has to be active as long as data need to be read.

Figure 32:
Reading of Single Register Byte

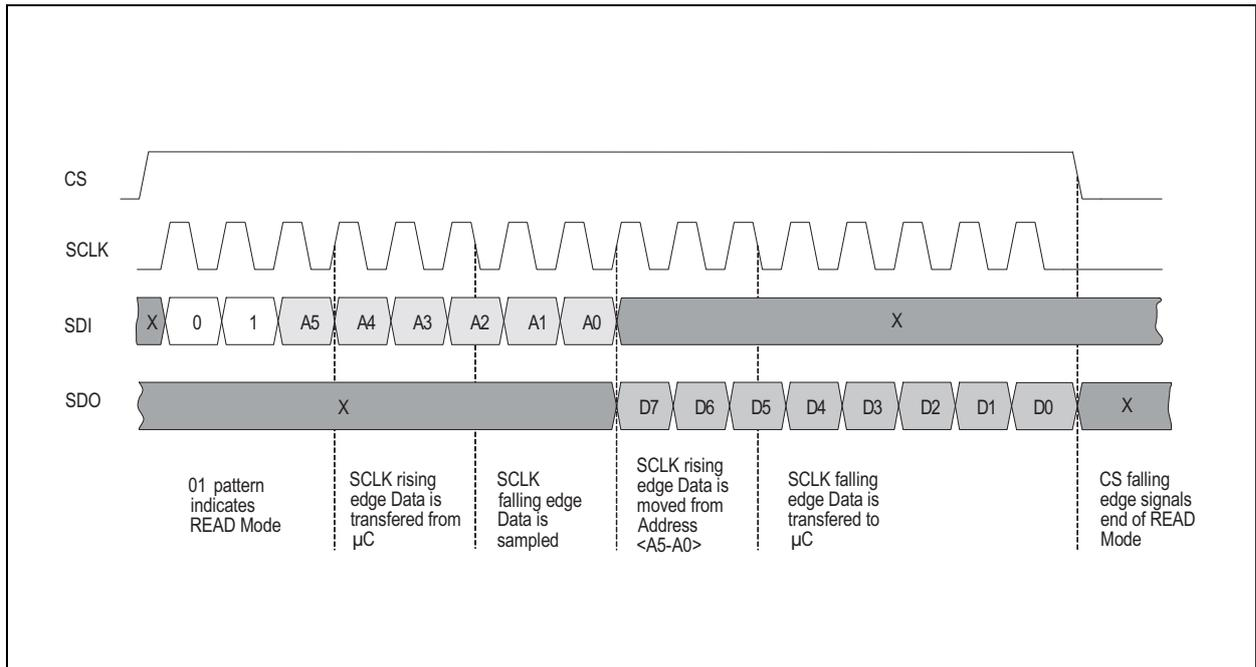
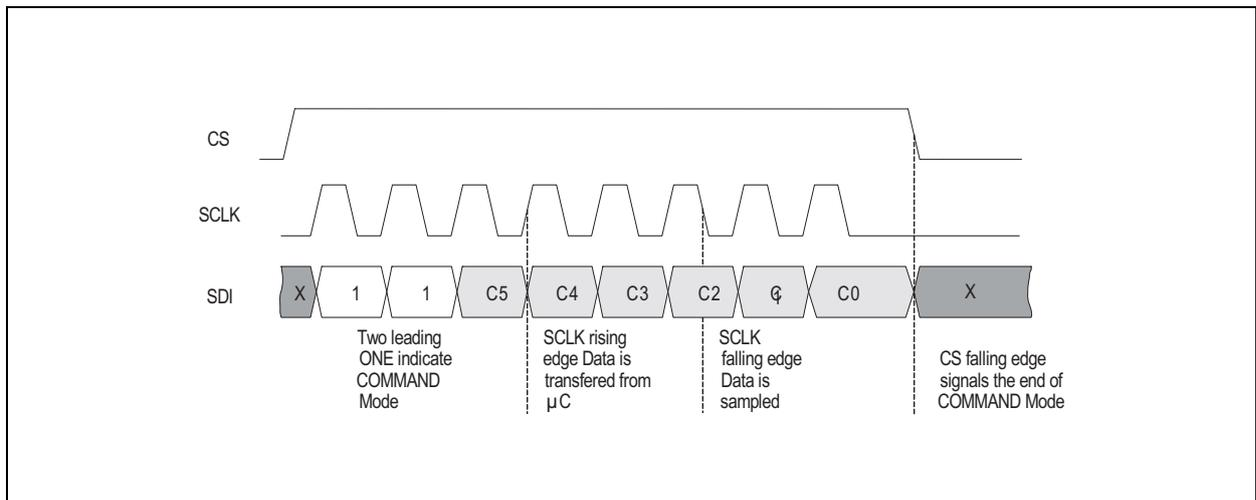

Figure 33:
Send Direct COMMAND Byte



SDI Timing

Figure 34:
SDI Timing Parameters

Symbol	Parameter	Conditions	Min	Typ	Max	Units
TCCLK	Time CS to Sampling Data		150			ns
TDCLK	Time Data to Sampling Data		100			ns
THCL	SCLK High Time		70			ns
TCLK	SCLK period		166			ns
TCLKCS	Time Sampling Data to CS down		150			ns
TCST	CS Toggling time		500			ns

Figure 35:
SDI Timing Diagram

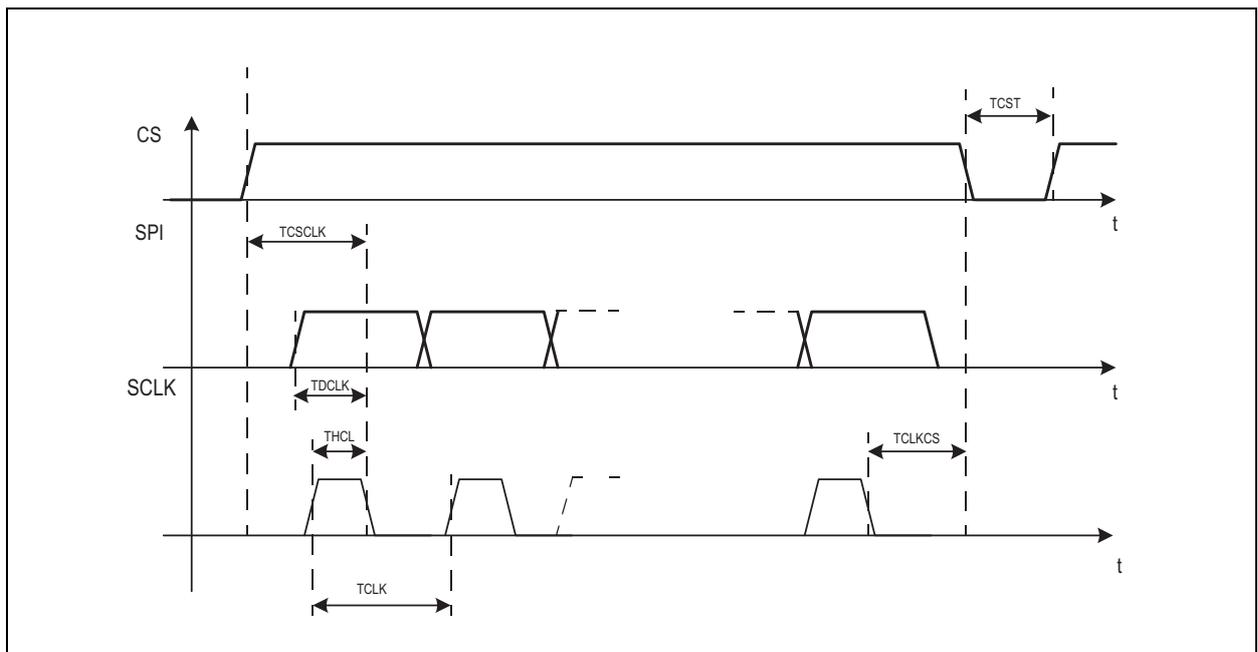

Channel Amplifier and Frequency Detector

Each of the 3 channels consists of a variable gain amplifier (VGA) with automatic gain control (AGC) and a frequency detector. When the AS3933 is in listening mode (waiting for RF signal) the gain of all channel amplifiers is set to maximum. The frequency detector counts the zero crossing of the amplified RF signal to detect the presence of the wanted carrier. As soon as the carrier is detected the AGC is enabled, the gain of the VGA is reduced and set to the right value. The RSSI (Received Signal Strength Indicator) represents how strong the input signal is and it is the inverse representation of the gain of the VGA. In fact, if for example the input signal is very strong the AGC will reduce the gain of the VGA. The gain reduction will correspond to a big RSSI, as it is the inverse of the gain setting of the VGA (small gain corresponds to a big RSSI and vice versa).

The AS3933 is a pretty wide LF wake-up receiver and can work between 15 kHz and 150 kHz. Once the carrier frequency has been chosen the user must set the amplifier working in the appropriate frequency band using the bits `R8<7:5>`, as described in the [Figure 36](#).

It is possible to boost the gain of the amplifiers for +3dB with an improvement of the sensitivity, as shown in the [Figure 14](#) (`R2<5>=1`). The gain boost will increase the current consumption of 100nA (typ) per channel. In case the lowest frequency band is used (15kHz – 23 kHz) the gain boost is automatically enabled from the logic.

It is possible to enable/disable individual channels, in case not all three channels are needed. This enables to reduce the current consumption by 1.5 μ A (typ.) per channel.

Frequency Detector / RSSI / Channel Selector

The frequency detection is based on a zero crossing counter and uses the Clock Generator as time base. This counter counts the zero crossing of the input signal within a time window defined by the clock generator and if it matches to the expected value it enabled the AGC (the RSSI measurement can get started). The Clock Generator can be based either on the internal RC-oscillator or on the Crystal oscillator or on the external clock source. The details on the choice of the Clock Generator are discussed in the [Clock Generator](#). The Clock Generator generates time windows equal to N times its period, where N depends on the operating frequency band, as shown in the [Figure 36](#).

Figure 36:
Bit Setting for the Operating Frequency Range and Time Windows Generation for the Frequency Detection

R8<7>	R8<6>	R8<5>	N	Operating Frequency Range [kHz]
0	0	0	4	95-150
0	0	1	6	65-95
0	1	0	10	40-65
0	1	1	18	23-40
1	1	1	14	15-23

The frequency detection is successful if in two consecutive time windows the zero threshold counter detects M zero crossing, where M depends also on the operating frequency range. The frequency detection criteria can be tighter or more relaxed according to the setup described in R2<1:0> (see Figure 36).

Figure 37:
Tolerance Settings for Frequency Detection in the Bands 23-150 kHz

R2<1>	R2<0>	M
0	0	16±6
0	1	16±4
1	0	16±2
1	1	n.a

Figure 37 shows the value of M for the different tolerance settings for the operating frequency bands from 23 to 150 kHz. Figure 38 shows M in case the operating frequency range is the lowest one (15 to 23 kHz).

Figure 38:
Tolerance Settings for Frequency Detection in the Bands 15-23 kHz

R2<1>	R2<0>	M
0	0	8±3
0	1	8±2
1	0	8±1
1	1	n.a

The AGC starts working after the frequency detection. At the beginning the gain in the VGA is set to maximum and the AGC reduce it according to the received signal input level. The AGC needs maximum 35 carrier periods to settle, getting a stable RSSI.

The AGC can operate in two modes:

- AGC down only ($R1<5>=0$)
- AGC up and down ($R1<5>=1$)

If the AGC down only mode is selected, the AGC can only decrease the gain for the whole duration of the data reception; in this mode the system holds the RSSI peak.

When the AGC up and down mode is selected, the RSSI can dynamically follow the input signal strength variation in both directions.

The RSSI is available for all 3 channels at the same time and it is stored in 3 registers ($R10<4:0>$, $R11<4:0>$, $R12<4:0>$). Once the RSSI gets stable (maximum after 35 carrier periods after frequency detection) the channel selector checks which channel receives the strongest signal. The channel selector compares the RSSI on the active channels and freezes the AGC on the channels which have the smaller RSSI. From this time on the AGC is active only on the selected channel. It is possible to set things back having the AGC active on all channels just sending a `clear_wake` (sets the chip back to listening mode) or `reset_RSSI` (resets the ACG) direct command.

Both AGC modes (only down or down and up) can also operate with time limitation. This option allows AGC operation only in time slot of $256\mu\text{s}$ after the frequency detection (during carrier burst), then the RSSI is frozen till the wake-up or RSSI reset occurs (`clear_wakeup` or `reset_RSSI`).

The RSSI is reset either with the direct command `'clear_wakeup'` or `'reset_RSSI'`. The `'reset_RSSI'` command resets only the VGA setting but does not terminate wake-up frequency detection condition. This means that if the signal is still present the new AGC setting (RSSI) will appear not later than 35 LF carrier periods after the command was received. The AGC setting is reset during data receiving if for duration of 3 Manchester half symbols no carrier is detected. If the wake-up IRQ is cleared the chip will go back to listening mode.

In case the maximum amplification at the beginning is a drawback (e.g. in noisy environment) it is possible to set a smaller starting gain on the amplifier, according to the [Figure 39](#). In this way it is possible to reduce the false frequency detection.

Figure 39:
Bit Setting of Gain Reduction

R4 <3>	R4 <2>	R4 <1>	R4 <0>	Gain Reduction
0	0	0	0	No gain reduction
0	0	0	1	n.a.
0	0	1	0 or 1	n.a.
0	1	0	0 or 1	-4dB
0	1	1	0 or 1	-8dB
1	0	0	0 or 1	-12dB
1	0	1	0 or 1	-16dB
1	1	0	0 or 1	-20dB
1	1	1	0 or 1	-24dB

Antenna Damper

In case the chip needs to deal with higher field strengths the antenna damper can be enabled. The antenna damper consists of internal resistors which can be connected in parallel to the external resonator as shown in [Figure 40](#). It is possible to enable the antenna damper with the bit R1<4> and the value of the resistor can be chosen with the bits R4<5:4>. The shunt resistors degrade the quality factor of the external resonator by reducing the signal at the input of the amplifier. In this way the resonator sees a smaller parallel resistance (in the band of interest) which degrades its quality factor in order to increase the linear range of the channel amplifier (the amplifier doesn't saturate in presence of bigger signals). [Figure 40](#) shows the bit setup.

Figure 40:
Antenna Damper Bit Setup

R4<5>	R4<4>	Shunt Resistor
0	0	1 kΩ
0	1	3 kΩ
1	0	9 kΩ
1	1	27 kΩ

Figure 41:
Antenna Damper

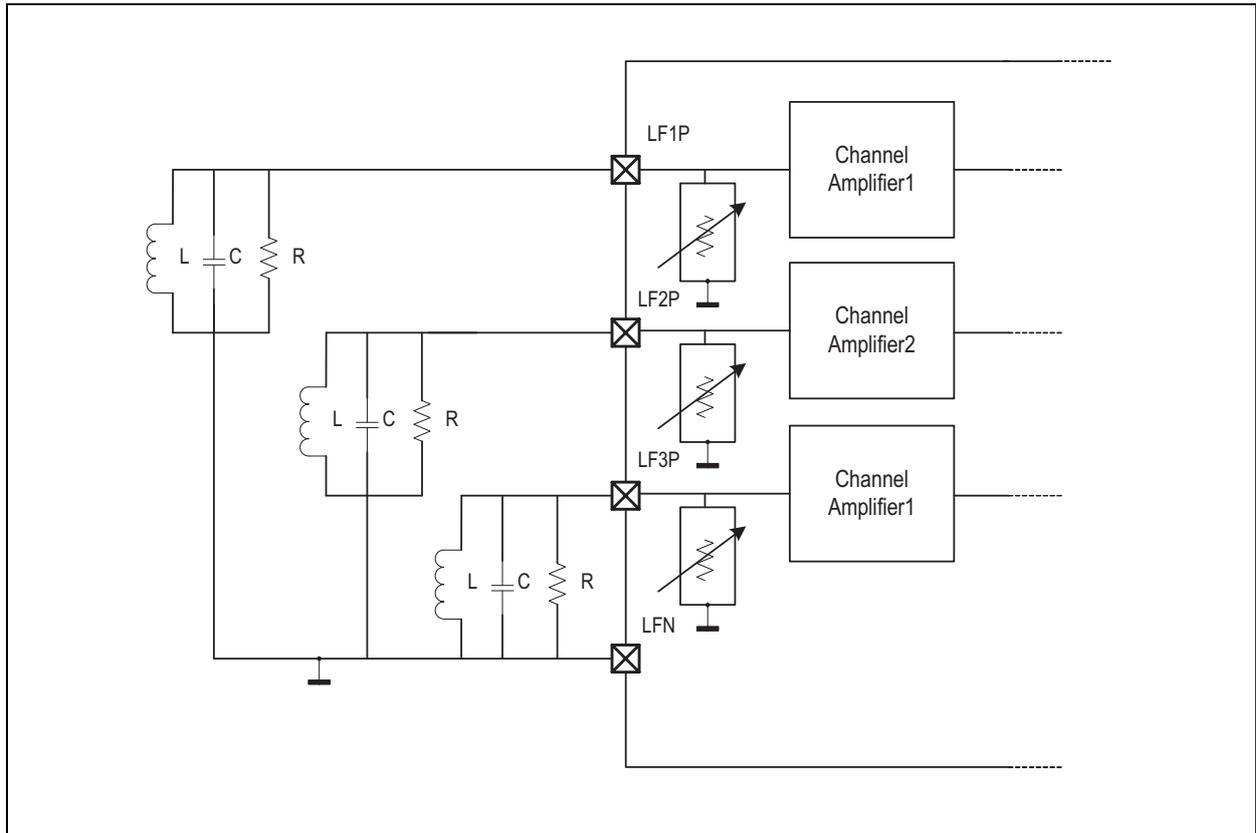

Demodulator / Data Slicer

As soon as the AS3933 detects successfully the frequency and the RSSI has got stable the channel selector compares the RSSI on all active channels and connects the channel amplifier which has the biggest RSSI to the demodulator. The channel selector needs 32 RF carrier periods to take this decision. The output signal (amplified LF carrier) of selected channel is connected to the input of the demodulator.

The demodulator takes the signal to base-band and recovers two signals from the amplified RF signal; a fast and a slow envelop. Those two signals are fed to the data slicer, which is a comparator with programmable hysteresis. At the output of the data slicer are streamed the digital received bits. A concept block diagram is shown in the [Figure 42](#).

Figure 42:
Concept Block Diagram

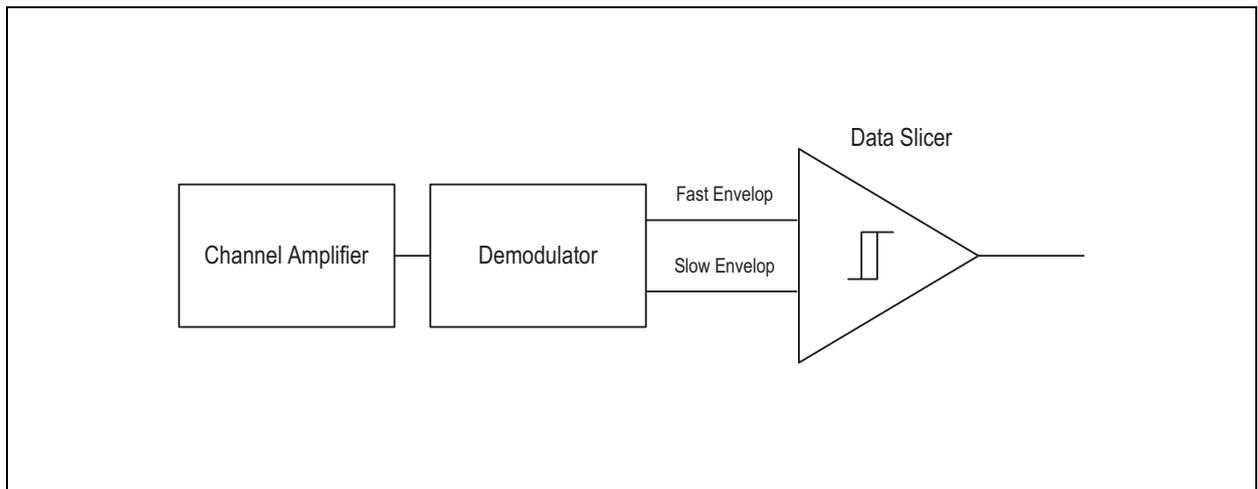
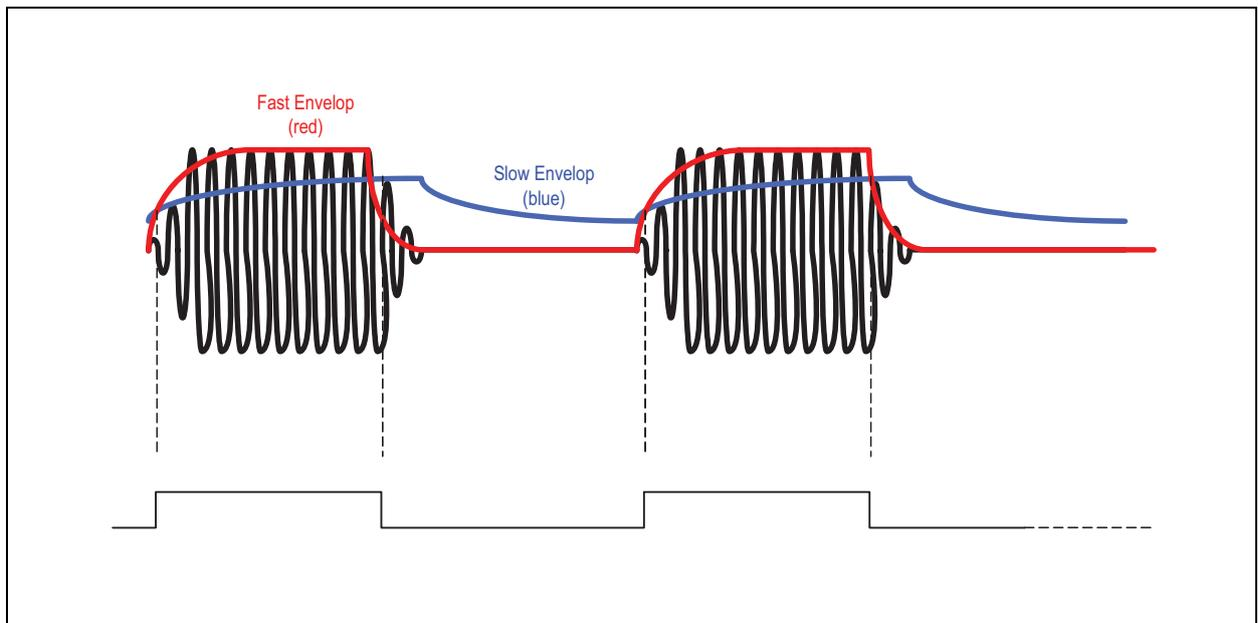

Figure 43:
Envelop Detector Signals - Dynamic Threshold



The performance of the demodulator can be optimized according to bit rate and preamble length as described in [Figure 44](#) and [Figure 45](#).

Figure 44:
Bit Setup of the Fast Envelope for Different Symbol Rates

R3<2>	R3<1>	R3<0>	Symbol Rate [Manchester Symbols/s]
0	0	0	4096
0	0	1	2184
0	1	0	1490
0	1	1	1130
1	0	0	910
1	0	1	762
1	1	0	655
1	1	1	512

On one hand the fast envelope's time constant (R3<2:0>) needs to be adjusted to the desired symbol rate as shown in Figure 44. However, decreasing the fast envelope's time constant also means that more noise will be injected due to the wider band. On the other hand, the slow envelop signal acts as an average of the incoming data. Therefore, the bigger its time constant is, the better will be the noise rejection. Yet, a bigger time constant of the slow envelop (R3<5:3>) requires a longer preamble in order to settle to the correct value. The minimum preamble length as a function of the slow envelope's settings is given in Figure 45.

Figure 45:
Minimum Required Preamble Lengths as Function of Slow Envelop Settings

R3<5>	R3<4>	R3<3>	Minimum Preamble Length [ms]
0	0	0	0.8
0	0	1	1.15
0	1	0	1.55
0	1	1	1.9
1	0	0	2.3
1	0	1	2.65
1	1	0	3
1	1	1	3.5

Note(s) and/or Footnote(s):

1. These times are minimum required, but it is recommended to prolong the preamble.

With the bits R3<6> and R3<7> it is possible to change the hysteresis on the data slicer comparator (only positive, positive negative, 20mV, 40mV).

The slow envelop signal (blue signal in Figure 43) represents the average of the demodulated signal, therefore acts as a reference signal for the data slicer. In case the chosen protocol has a duty cycle far away from 50% (for example in the NRZ protocol there can be several consecutive ones or zeros) the slow envelop signal would not be a stable reference signal for the data slicer. In this case the data slicer can also work with an absolute threshold (R1<7>), as shown in the Figure 46. Should the absolute threshold be enabled the bits R3<2:0> would not influence the performance. It is even possible to reduce the absolute threshold in case the environment is not particularly noisy (R2<7>).

As the input signal may be damped due to physical influences of the transmitter environment, the symbol rate needs to be adapted (lowered) if absolute threshold is enabled to ensure a proper detection of the wake-up signal. The peak level of the signal should be reached within 1/3 of the symbol duration which is defined as two times the bit duration. The bit duration is defined in register R7 <4:0> as a function of the Clock Generator periods.

Figure 46:
Envelop Detector Signals - Absolute Threshold

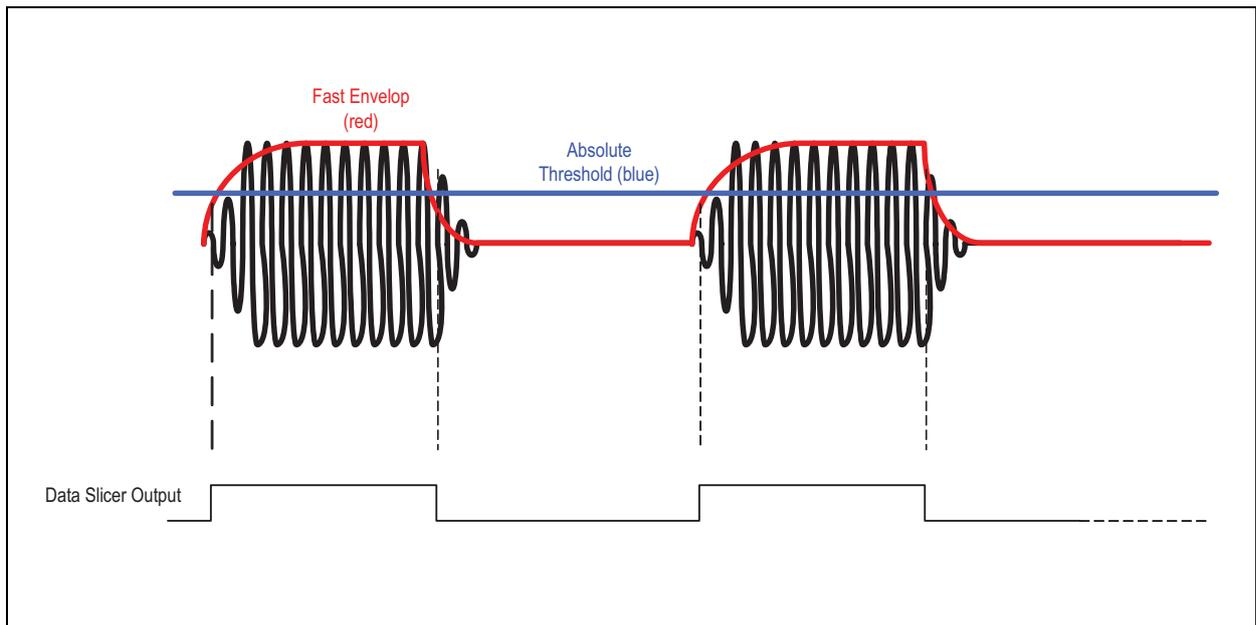

Correlator

In order to prevent that the AS3933 wakes up the host system (MCU) from noise or disturbers (LF transmitter within the field) the internal correlator checks that the bit sequence delivered from the data slicer corresponds to stored pattern. The wanted pattern can be stored in the registers $R5<7:0>$ and $R6<7:0>$. The data correlation is performed only if the correlator is enabled ($R1<1>=1$) and can start only after frequency detection.

The pattern correlation is successful (Wake goes high) only if the bits sequence (pattern) and its timing (duration of the single bit) matches.

Pattern: Bit and Symbol Definition in Manchester Code

The AS3933 can correlate the incoming pattern without the help of an external unit (MCU). The chosen pattern must be Manchester encoded. In the Manchester code each “Symbol” is defined by a transition (high-to-low for 1 and low-to-high for 0), therefore consists of two “bits”. In the [Figure 47](#) it is shown, as an example, how the encoding technique works. In this sequence a simple message made up by 3 symbols (1 0 1) is Manchester encoded. In the Manchester encoded bit stream there can not be three consecutive zeros or ones (in each symbol there is always a transition). This helps the receiver to recover the clock.

Figure 47:
Manchester Encoding

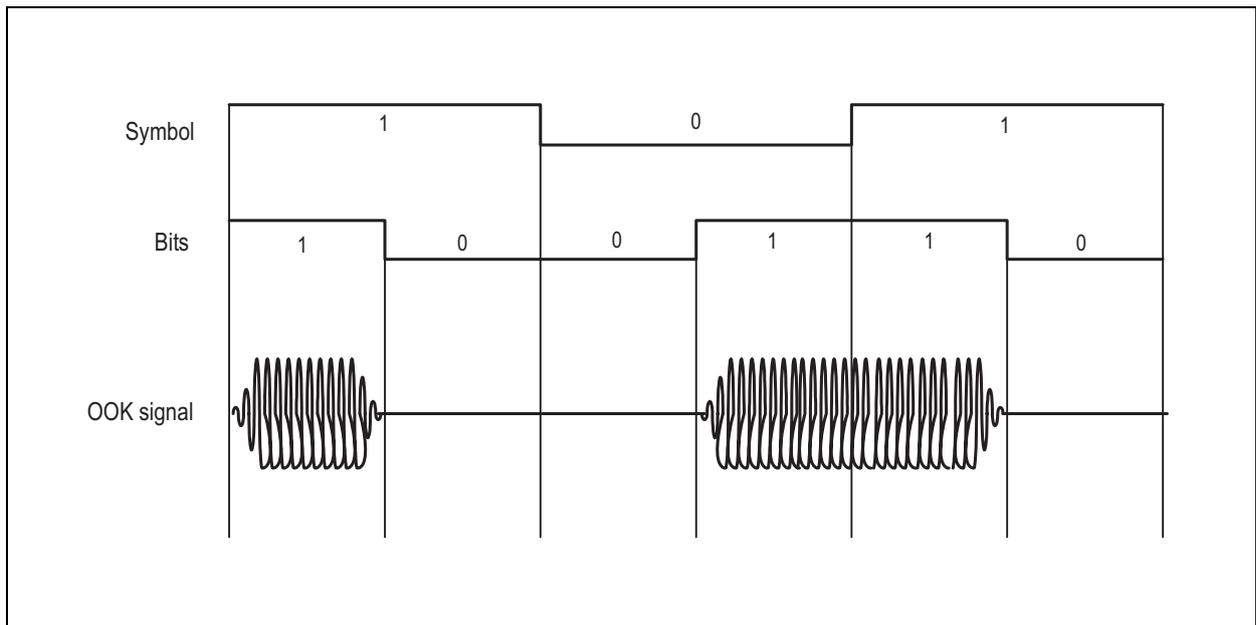

The bit duration is defined in the register [R7<4:0>](#) according to the [Figure 48](#) as function of the Clock Generator periods.

Figure 48:
Bit Rate Setup

R7<4>	R7<3>	R7<2>	R7<1>	R7<0>	Bit Duration in RTC Clock Periods
0	0	0	1	1	4
0	0	1	0	0	5
0	0	1	0	1	6
0	0	1	1	0	7
0	0	1	1	1	8
0	1	0	0	0	9
0	1	0	0	1	10
0	1	0	1	0	11
0	1	0	1	1	12
0	1	1	0	0	13
0	1	1	0	1	14
0	1	1	1	0	15
0	1	1	1	1	16
1	0	0	0	0	17

R7<4>	R7<3>	R7<2>	R7<1>	R7<0>	Bit Duration in RTC Clock Periods
1	0	0	0	1	18
1	0	0	1	0	19
1	0	0	1	1	20
1	0	1	0	0	21
1	0	1	0	1	22
1	0	1	1	0	23
1	0	1	1	1	24
1	1	0	0	0	25
1	1	0	0	1	26
1	1	0	1	0	27
1	1	0	1	1	28
1	1	1	0	0	29
1	1	1	0	1	30
1	1	1	1	0	31
1	1	1	1	1	32

The user can define the pattern to correlate in the registers [R5<7:0>](#) and [R6<7:0>](#) and can decide whether the stored pattern is a bit representation (16 Manchester bits corresponds to 8 Symbols) if [R0<7>](#)=0 or the symbol representation (16 symbols corresponds to 32 bits) of the pattern if [R0<7>](#)=1. The number of different pattern is 2^{SYM} , where SYM is the number of Manchester symbols. In case the [R5<7:0>](#) and [R6<7:0>](#) represent the bit sequence of the pattern there are 256 different possible combinations, while in case they are the symbol representation there are 65536 different patterns.

Wake-Up Protocol

The AS3933 can support different protocols:

- Frequency detection only (no pattern correlation)
- Single pattern detection
 - 16-bit pattern
 - 32-bit pattern
- Double pattern detection
 - 16-bits pattern
 - 32-bits pattern

The wake-up state can be terminated either by the host system (MCU) with the direct command 'clear_wake' sent over SPI (see direct command details in [Figure 29](#)) or with a time-out option. In case the latter is used the host system (MCU) does not need to take any action to terminate the wake-up state and the chip is set back to listening mode automatically after a predefined time. It is possible to set the duration of the time-out with the register [R7<7:5>](#), as shown in the [Figure 49](#).

Figure 49:
Timeout Setup

R7<7>	R7<6>	R7<5>	Time Out
0	0	0	disabled
0	0	1	50 msec
0	1	0	100 msec
0	1	1	150 msec
1	0	0	200 msec
1	0	1	250 msec
1	1	0	300 msec
1	1	1	350 msec

Wake-Up Protocol: Frequency Detection Only

Figure 50:
Wake-Up Protocol Overview Without Pattern Detection

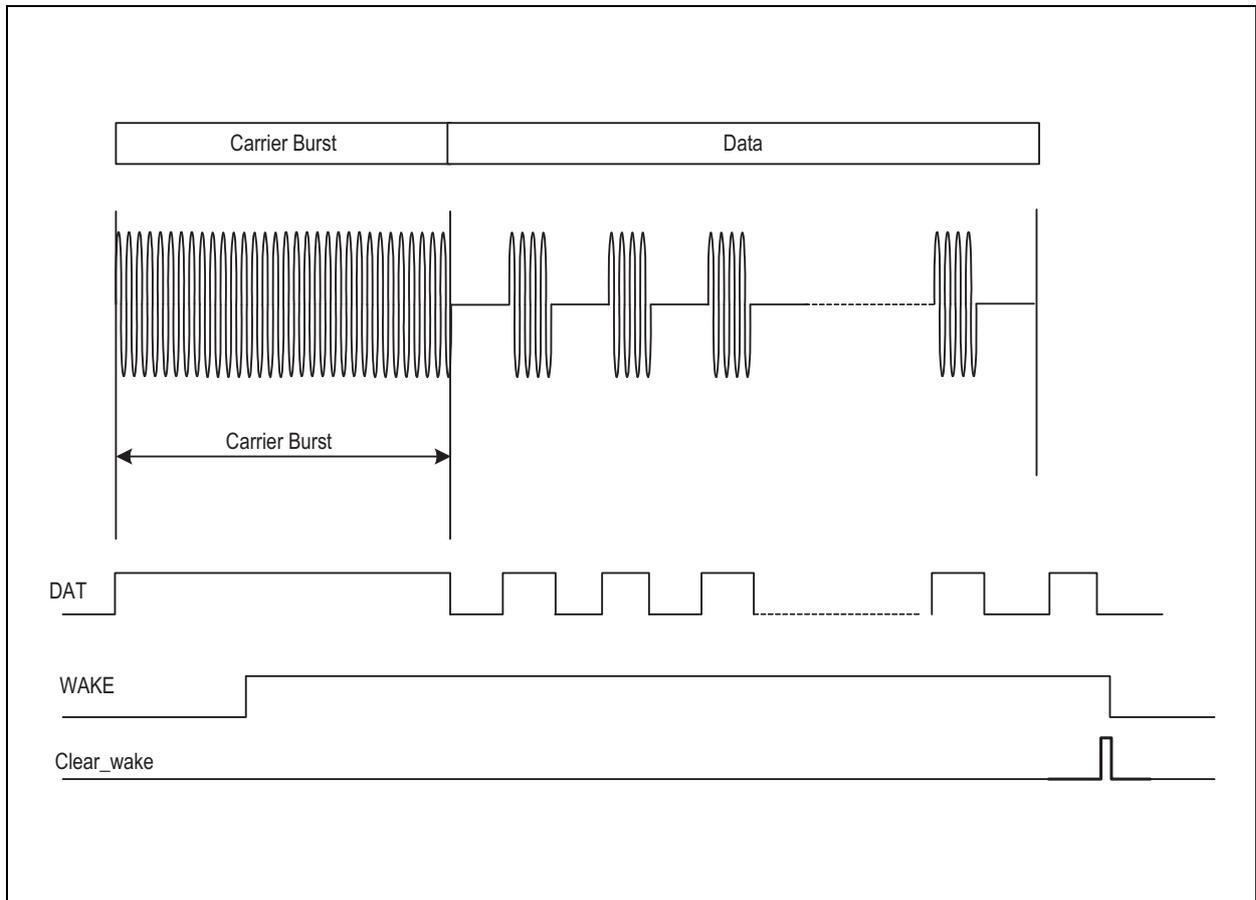

In case the pattern correlation is disabled ($R1<1>=0$) the AS3933 wakes up upon detection of the carrier frequency only as shown in Figure 50. The minimum duration of the carrier burst in order to ensure that AS3933 wakes up and the RSSI is settled is specified in the Figure 52. In addition the carrier burst does not have to be longer than 155 periods of the Clock Generator (Crystal oscillator or RCO or External Clock). As shown in the Figure 20, the AS3933 after the detection of the carrier goes directly from the Listening mode to Data receiving mode after settling the RSSI.

Wake-Up Protocol: Pattern Detection Enabled

In case the pattern correlation is enabled ($R1<1>=1$) the AS3933 generates a wake-up interrupt if the wake-up protocol is fulfilled. The communication protocol consists of a carrier burst, a preamble (0101010.... ON/OFF modulated carrier) and the 16-bit pattern. In case the double pattern option is enabled ($R1<2>=1$) the 16-bit pattern has to be repeated 2 times consequentially (2 times the same pattern). The signal on the WAKE pin goes high one bit after the end of the pattern and the data transmission can get started.

A graphic representation of the wake-up protocol is shown in the [Figure 51](#).

Figure 51:
Wake-Up Protocol Overview if Pattern Detection is Enabled

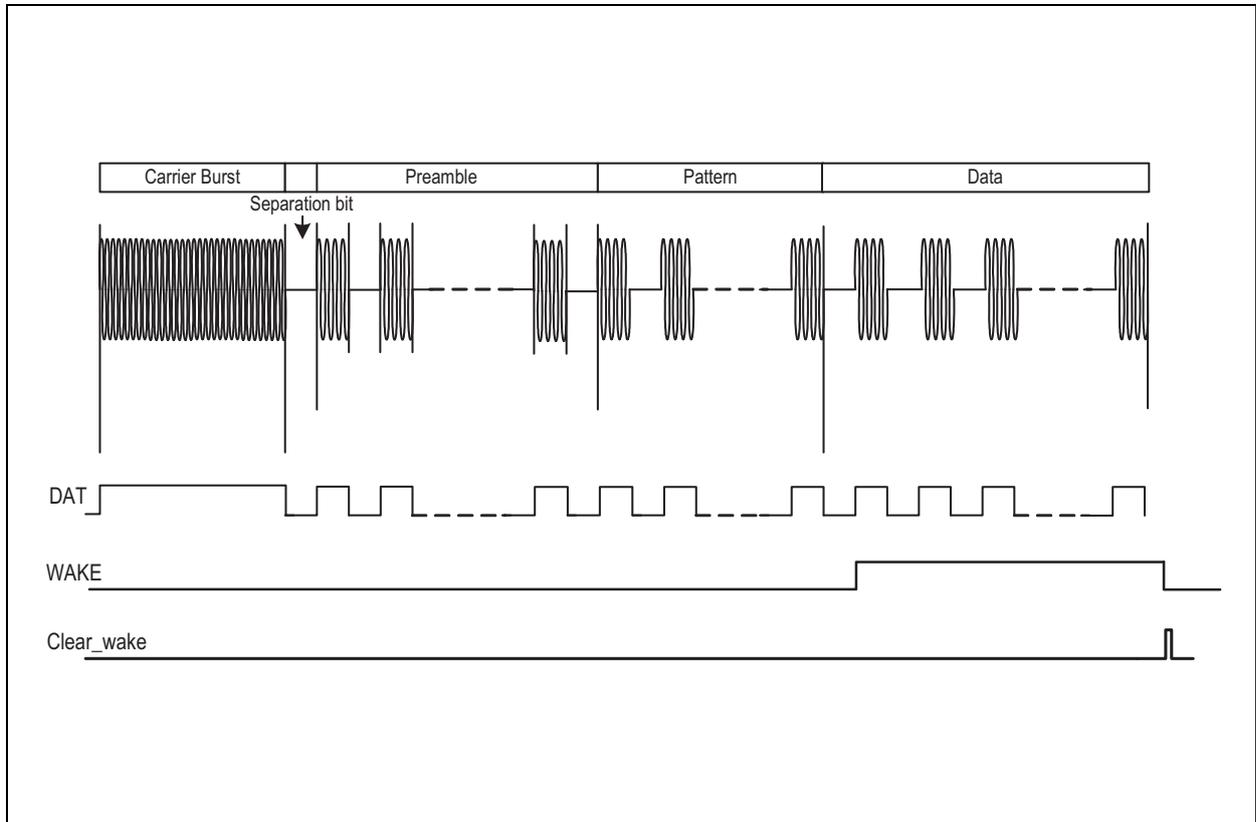

The minimum length for the carrier burst depends on the operating frequency range (see [Figure 36](#) bits [R8<7:5>](#)) and is described in the [Figure 52](#).

Figure 52:
Minimum Duration of the Carrier Burst

Operating Frequency Range [kHz]	Minimum Duration of the Carrier Burst
95-150	$16 \cdot T_{clk} + 16T_{carr}$
65-95	$28 \cdot T_{clk} + 16T_{carr}$
40-65	$52 \cdot T_{clk} + 16T_{carr}$
23-40	$96 \cdot T_{clk} + 16T_{carr}$
15-23	$92 \cdot T_{clk} + 8T_{carr}$

Note(s) and/or Footnote(s):

1. Tclk is the period of the clock generator.
2. Tcarr is the period of the carrier.

If the carrier burst is shorter than what has been specified in the [Figure 52](#), then the frequency detection is not guaranteed. In order to fulfill the protocol the carrier burst must be shorter than 155 periods of the clock generator (crystal oscillator or RCO or external clock). The carrier burst must be followed by a separation bit and at least 6 bits preamble (101010). The separation bit must last as half Manchester symbol (see paragraph [Pattern: Bit and Symbol Definition in Manchester Code](#)). The preamble and the pattern cannot be longer than 30 symbols in sum in case 16-bit pattern detection is enabled and 46 symbols if the 32-bit pattern detection is enabled.

In case the ON/OFF option is enabled ($R0<5>=1$) the minimum duration of the carrier burst must be prolonged by the OFF time defined in the $R4<7:6>$.

Should the carrier burst be longer than what is defined in the [Figure 52](#) or the number of preamble bits longer than what has been specified above a false wake-up event might be recorded in the register $R13<7:0>$.

If the Scan Mode be enabled ($R0<4>=1$) the minimum duration of the carrier burst is defined in the [Figure 53](#).

Figure 53:
Minimum Duration of the Carrier Burst in Case the Scanning Mode is Enabled

Operating Frequency Range [kHz]	Minimum Duration of the Carrier Burst
95-150	$80 \cdot T_{clk} + 16 T_{carr}$
65-95	$92 \cdot T_{clk} + 16 T_{carr}$
40-65	$180 \cdot T_{clk} + 16 T_{carr}$
23-40	$224 T_{clk} + 16 T_{carr}$
15-23	$220 \cdot T_{clk} + 8 T_{carr}$

Manchester Decoder and Clock Recovery

In case the Manchester decoder is enabled ($R1<3>=1$) the AS3933 decodes the incoming Manchester bits automatically and the Manchester decoded data are displayed on the DAT pin and the Manchester recovered clock on the CL_DAT. The data coming out from the DAT pin are stable (and therefore can be acquired) on the rising edge of the CL_DAT clock, as shown in Figure 54.

Figure 54:
Synchronization of Data with the Manchester Recovered Clock

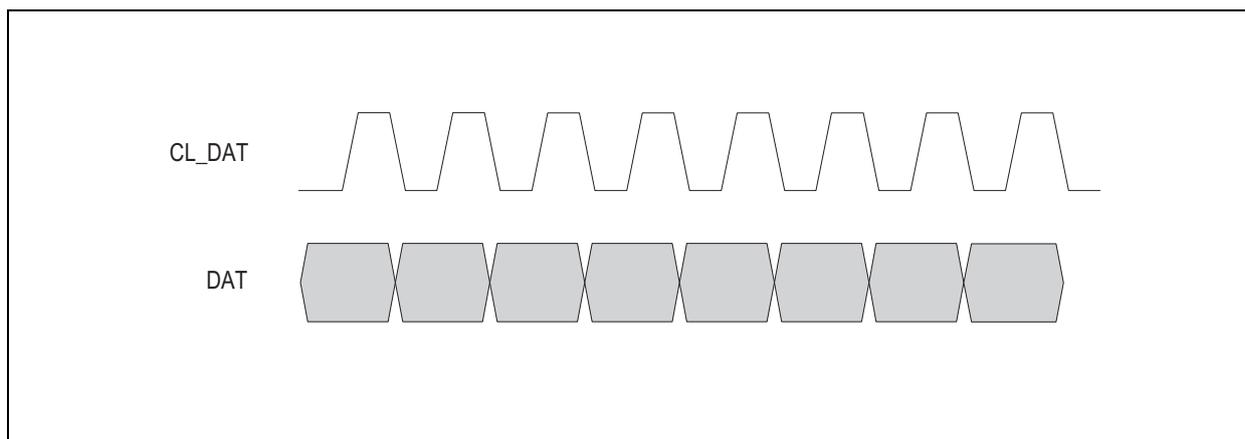

In case a Manchester timing violation happens, the signal on SPO goes high for a duration of 4 periods of internal clock (either crystal oscillator or RCO or external clock).

False Wake-Up Register

The wake-up strategy in the AS3933 is based on 2 steps:

1. Frequency Detection: In this phase the frequency of the received signal is checked.
2. Pattern Correlation: Here the pattern is demodulated and checked whether it corresponds to the valid one.

If there is a disturber or noise capable to overcome the first step (frequency detection) without producing a valid pattern, then a false wake-up call happens. Each time this event is recognized a counter is incremented by one and the respective counter value is stored in a memory cell (false wake-up register). Thus, the microcontroller can periodically look at the false wake-up register, to get a feeling how noisy the surrounding environment is and can then react accordingly (e.g. reducing the gain of the LNA during frequency detection, set the AS3933 temporarily to power down etc.), as shown in the Figure 55. The false wake-up counter is a useful tool to quickly adapt the system to any changes in the noise environment and thus avoid false wake-up events.

Most wake-up receivers have to deal with environments that can rapidly change. By periodically monitoring the number of false wake-up events it is possible to adapt the system setup to the actual characteristics of the environment and enables a better use of the full flexibility of AS3933.

Figure 55:
Concept of the False Wake-Up Register Together with the System

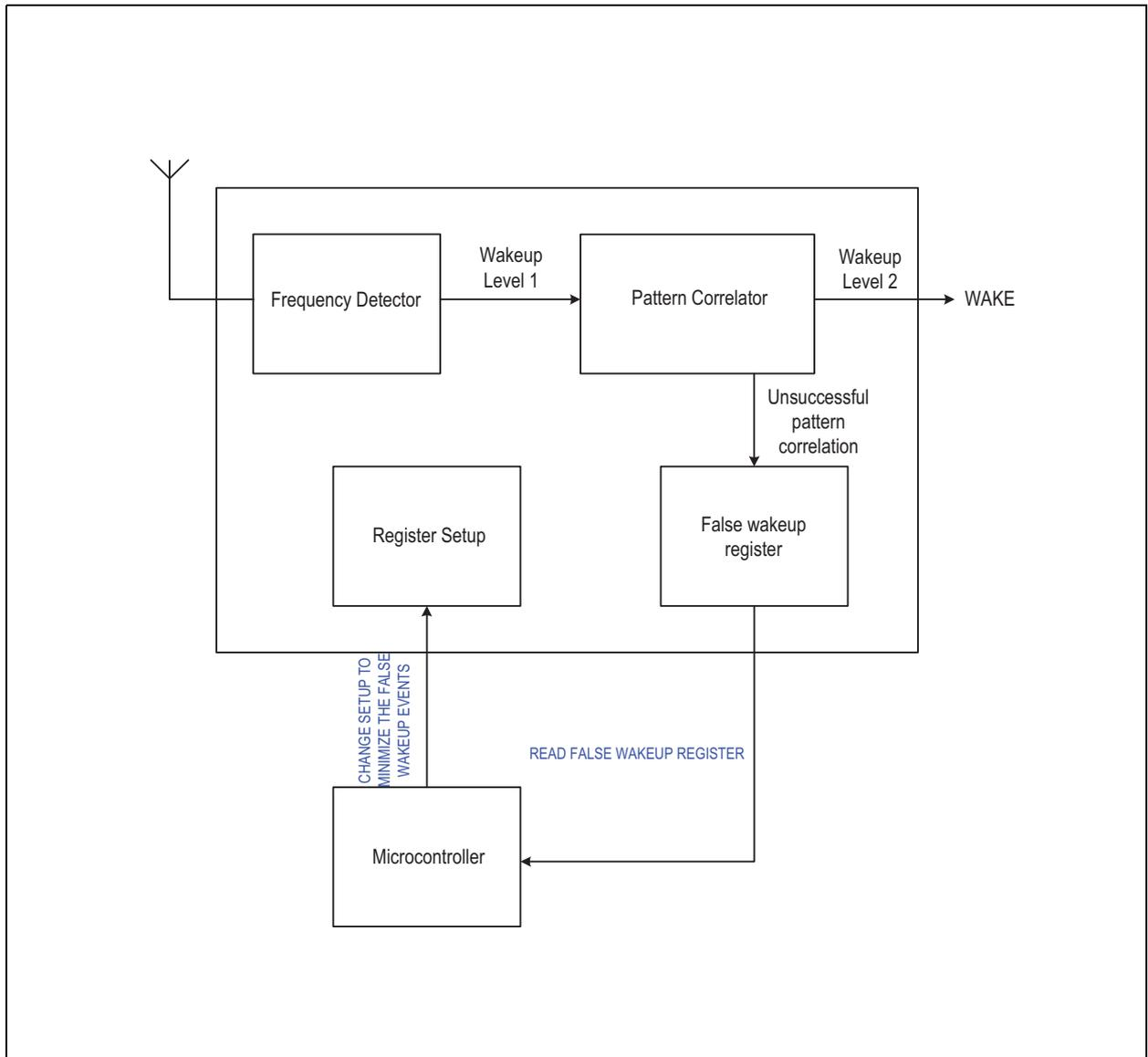

Clock Generator

The Clock Generator can be based on a crystal oscillator ($R1<0>=1$), the internal RC-oscillator ($R1<0>=0$), or an external clock source ($R1<0>=1$). The crystal oscillator has higher precision of the frequency with higher current consumption and needs three external components (crystal plus two capacitors). The RC-oscillator is completely integrated and can be calibrated to increase its precision. Should a digital clock already be available it can be applied directly to the XOUT pin (XIN to VDD).

Regardless which clock generator is chosen, the frequency of the Clock Generator must be set according to the carrier frequency. Figure 56 shows the dependency of the Clock Generator frequency from the carrier frequency and operating frequency band.

Figure 56:
Clock Generator Frequency vs Frequency Band

Carrier Frequency [kHz]	Clock Generator Frequency
15 – 23	$f_{RC} = f_{carr} \cdot \frac{14}{8}$
23-40	$f_{RC} = f_{carr} \cdot \frac{9}{8}$
40-65	$f_{RC} = f_{carr} \cdot \frac{5}{8}$
65 – 95	$f_{RC} = f_{carr} \cdot \frac{3}{8}$
95 - 150	$f_{RC} = \frac{f_{carr}}{4}$

It is possible to display the frequency of the clock generator on the CL_DAT pin writing $R2<3:2>=11$ and $R16<7>=1$.

Crystal Oscillator

In case the user decides to use the Crystal Oscillator as reference clock a 32.768 kHz quartz can be used in case the tolerance setting for the frequency detection is relaxed ($R2<1:0>=00$). Should this not be the case, then Figure 56 shows how the frequency of the quartz has to be chosen.

If the AS3933 works in the bandwidth 23-40 kHz, then it is recommended not to use the XTAL oscillator to avoid any coupling between the input antennas and the quartz.

Figure 57:
Characteristics of XTAL

Symbol	Parameter	Conditions	Min	Typ	Max	Units
	Crystal accuracy (initial)	Overall accuracy			±120	ppm
	Crystal motional resistance				60	KΩ
	Minimum Frequency	For 32.768 kHz crystal		25		kHz
	Typical Frequency			32.768		kHz
	Maximum Frequency			45		kHz
	Contribution of the oscillator to the frequency error			±5		ppm
	Start-up Time	Crystal dependent		1		s
	Duty cycle		45	50	55	%
	Current consumption			300		nA
	Calibration time	Periods of reference clock			65	cycles
	Current consumption			650		nA

RC-Oscillator

Figure 58:
Characteristics of RCO

Symbol	Parameter	Conditions	Min	Typ	Max	Units
	Calibration time	Periods of reference clock			65	cycles
	Current consumption			650		nA

In case the pattern detection and the Manchester decoder are not enabled ($R1<1>=0$ and $R1<3>=1$) the calibration on the RC-oscillator is not needed. Should this not be the case, the RC-oscillator has to be calibrated. The calibration of the RC-oscillator can be done in two different ways:

- Over SPI, the host system (MCU) has to be able to provide 65 clock pulses of a reference clock. In this case the host has to have a precise reference clock (quartz, resonator etc.).
- Using the internal calibration procedure based on the antenna resonator. Using this calibration method the RC-oscillator is automatically trimmed to the proper frequency, according to the operating frequency band. The precision of the calibration depends on the tolerances of the resonator of the first channel (LC connected to LF1P).

RC-Oscillator: Calibration via SPI. The calibration gets started with the Calib_RCosc direct command. Since no non-volatile memory is available on the chip, the calibration must be done every time after battery replacement. Since the Clock Generator defines the time base of the frequency detection, the selected frequency depends on the carrier frequency. The choice of the reference clock frequency delivered by the host (MCU) is the same as the choice of the frequency in case the crystal oscillator is used and it is shown in the [Figure 56](#).

To trim the RC-Oscillator, set the chip select (CS) to high before sending the direct command Calib_RCosc over SPI. Then 65 digital clock cycles of the reference clock (e.g. $125\text{kHz}/4=31.25\text{kHz}$) have to be sent on the clock bus (SCLK), as shown in [Figure 59](#). After that the signal on the chip select (CS) has to be pulled down.

The calibration is effective after the 65th reference clock edge and it will be stored in a volatile memory. In case the RC-oscillator is switched OFF or a power-on-reset happens (e.g. battery change) the calibration has to be repeated.

Figure 59:
RC-Oscillator Calibration via SPI

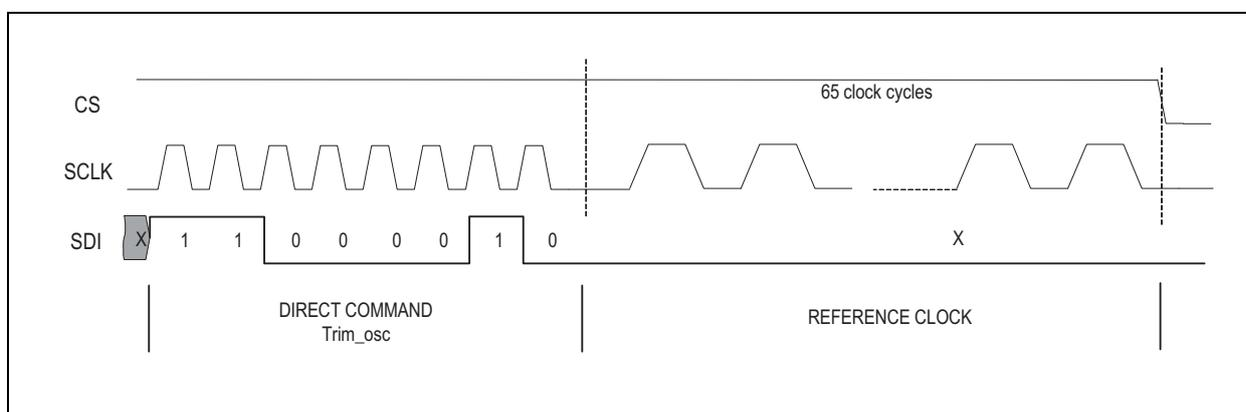

RC-Oscillator: Self Calibration. This procedure uses the LC-tank (antenna) connected to the channel 1 (LF1P) not as antenna but as resonator for an oscillator. The internal LC oscillator is therefore connected through a multiplexer to the external tank.

The LC-oscillator generates a clock which corresponds to the resonance frequency of the LC-tank. In a typical application the user designs the external resonators such to set the resonance frequency of the external LC-tank as close as possible to the carrier frequency. The mathematical relation between the oscillation frequency and the LC time constant is:

$$(EQ1) \quad F_{LC} = \frac{1}{2 \cdot \pi \cdot \sqrt{L \cdot C}}$$

Where:

L is the inductance and

C the capacitance of the external antenna

To start the calibration the direct command Calib_RCO_LC must be sent over the SPI and as soon as the bit R14<7> is high, the RC-oscillator will be calibrated. The calibrated frequency of the RC-oscillator depends on the carrier frequency and is automatically set to better perform the frequency detection, according to the Figure 56.

External Clock Source

To clock the AS3933 with an external signal, the external clock generator (R2<6> =1) and the crystal oscillator (R1<0>=1) need to be enabled. As shown in the Figure 4 the clock can be directly applied on the pin XOUT while the pin XIN must be connected to VDD. The clock characteristics are summarized in Figure 60.

Figure 60:
Characteristics of External Clock

Symbol	Parameter	Conditions	Min	Typ	Max	Units
VI	Low level		0		0.1*V _{DD}	V
Vh	High level		0.9*V _{DD}		V _{DD}	V
Tr	Rise-time				3	μs
Tf	Fall-time				3	μs

Note(s): In power down mode the external clock has to be set to a definite potential (VDD or ground).

The frequency of the external clock source must be set according to the Figure 56.

Antenna Tuning

The AS3933 offers the possibility to implement a fine antenna tuning. A block diagram shows how the tuning can be implemented with the help of the host system (MCU).

Figure 61:
Tuning Implementation

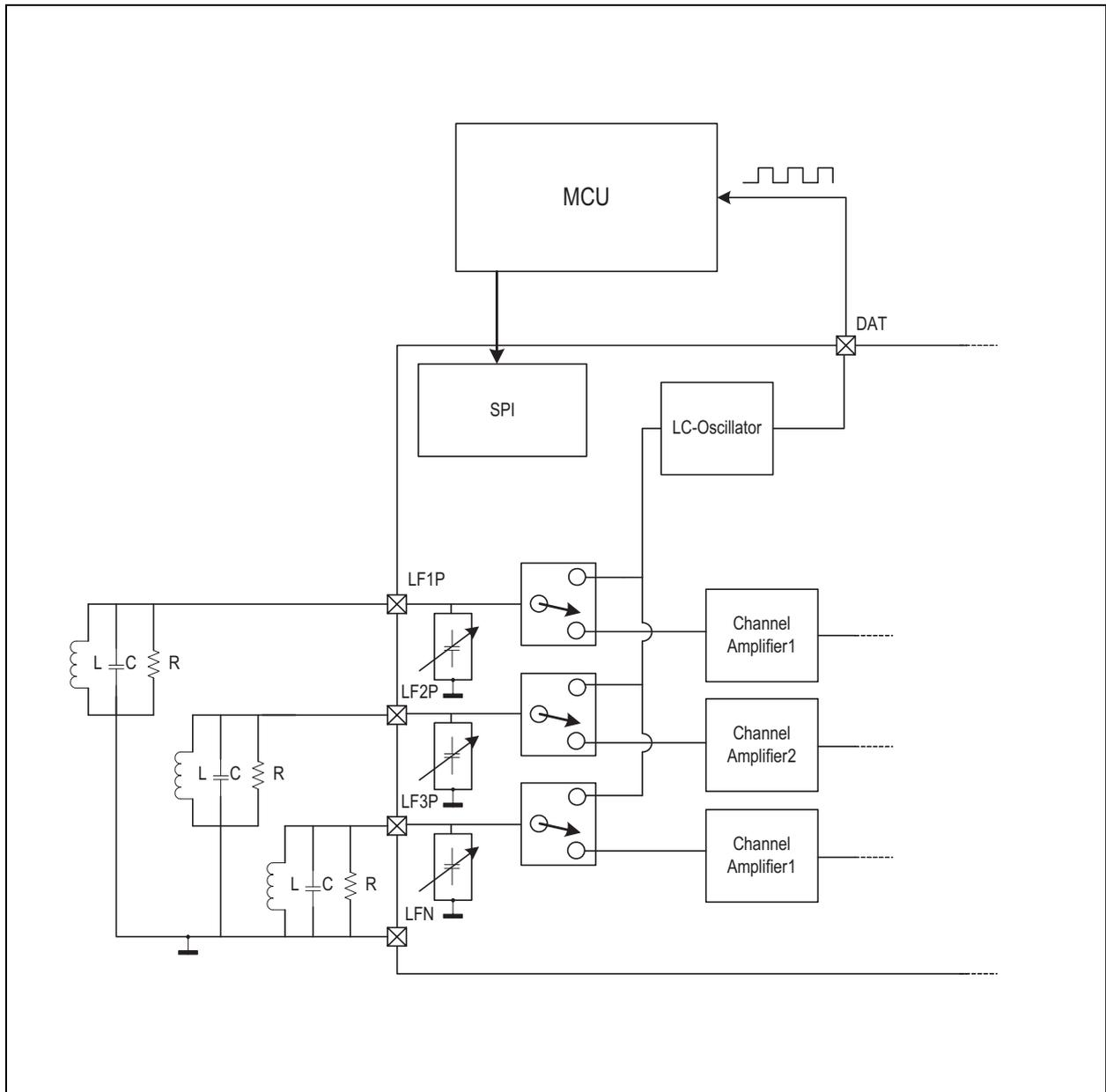

Each of the three antennas can be tuned with the internal capacitor banks. The capacitor can be connected or disconnected (adding or subtracting parallel capacitance to the external resonator) through registers `R17<4:0>`, `R18<4:0>` and `R19<4:0>`.

Figure 62:
Parallel Tuning Capacitance on the LF1P

R17	Capacitance on LF1P
R17<0>=1	Adds 1pF to LF1P
R17<1>=1	Adds 2pF to LF1P
R17<2>=1	Adds 4pF to LF1P
R17<3>=1	Adds 8pF to LF1P
R17<4>=1	Adds 16pF to LF1P

Figure 63:
Parallel Tuning Capacitance on the LF2P

R18	Capacitance on LF2P
R18<0>=1	Adds 1pF to LF2P
R18<1>=1	Adds 2pF to LF2P
R18<2>=1	Adds 4pF to LF2P
R18<3>=1	Adds 8pF to LF2P
R18<4>=1	Adds 16pF to LF2P

Figure 64:
Parallel Tuning Capacitance on the LF3P

R19	Capacitance on LF3P
R19<0>=1	Adds 1pF to LF3P
R19<1>=1	Adds 2pF to LF3P
R19<2>=1	Adds 4pF to LF3P
R19<3>=1	Adds 8pF to LF3P
R19<4>=1	Adds 16pF to LF3P

The Three channels can be tuned separately. The host system (MCU) has to connect the LC-oscillator to the antenna to measure the resonance frequency on the pin DAT. The host should measure the frequency on this pin and just changing register setting fine tune it to get it as close as possible to the nominal value of the carrier frequency. With the bits R16<2:0> it is possible to connect the LC-oscillator to the three different antennas.

Channel Selection in Scanning Mode and ON/OFF Mode

In case only 2 channels are active and one of the Low Power modes is enabled, then the channels 1 and 3 have to be active. If the chip works in ON-OFF mode and only one channel is active then the active channel has to be the channel 1. Both Low Power modes are not allowed to be enabled at the same time.

Package Drawings & Markings

The devices are available in a 16-pin TSSOP and QFN 4x4 16LD package.

Figure 65:
16-pin TSSOP Package Drawing

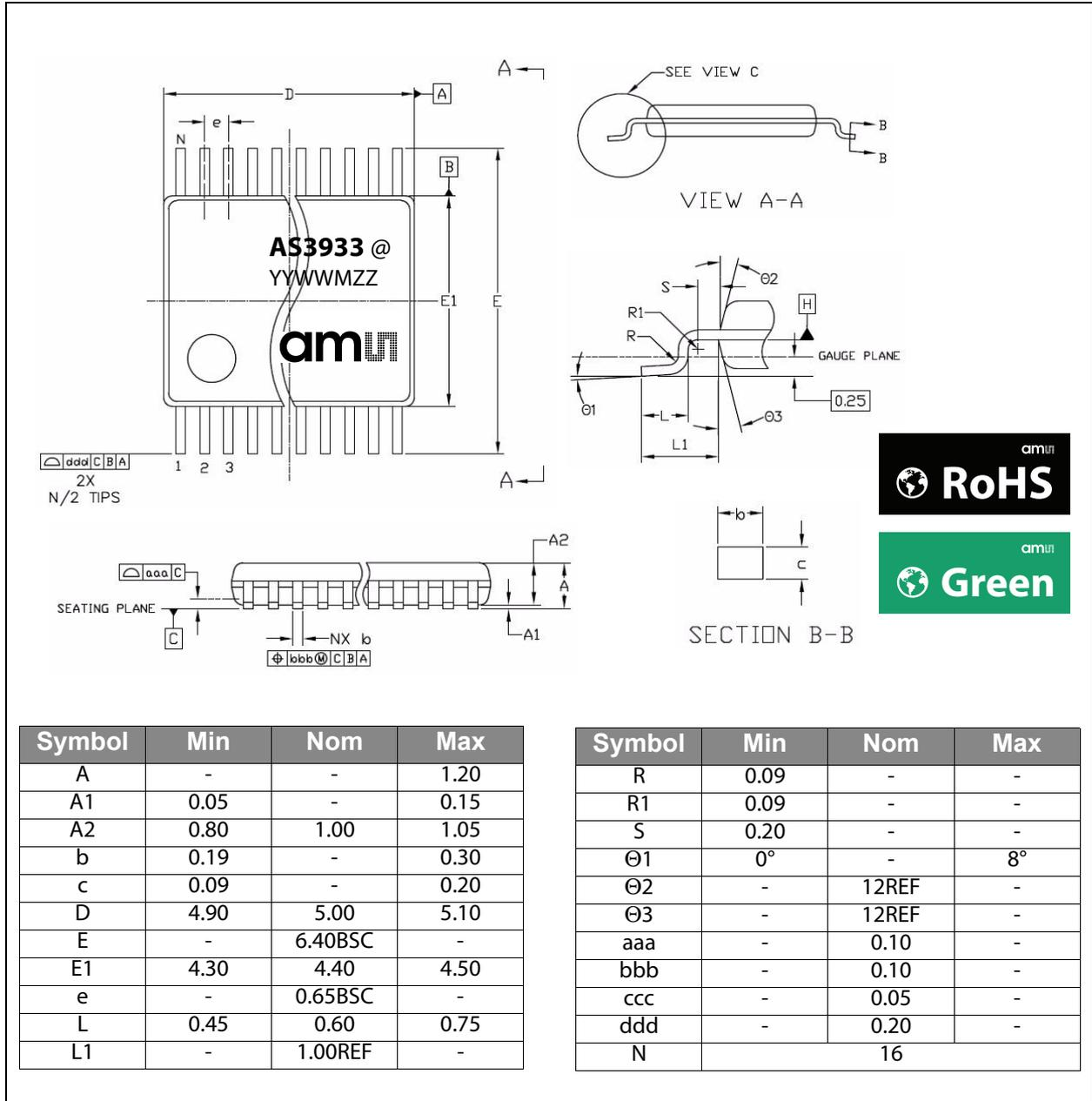

Note(s) and/or Footnote(s):

1. Dimensions & tolerancing conform to ASME Y14.5M-1994.
2. All dimensions are in millimeters. Angles are in degrees.

Figure 66:
Marking: YYWMZZ@

YY	WW	M	ZZ	@
Year (i.e. 10 for 2010)	Manufacturing Week	Assembly plant identifier	Assembly traceability code	Sublot identifier

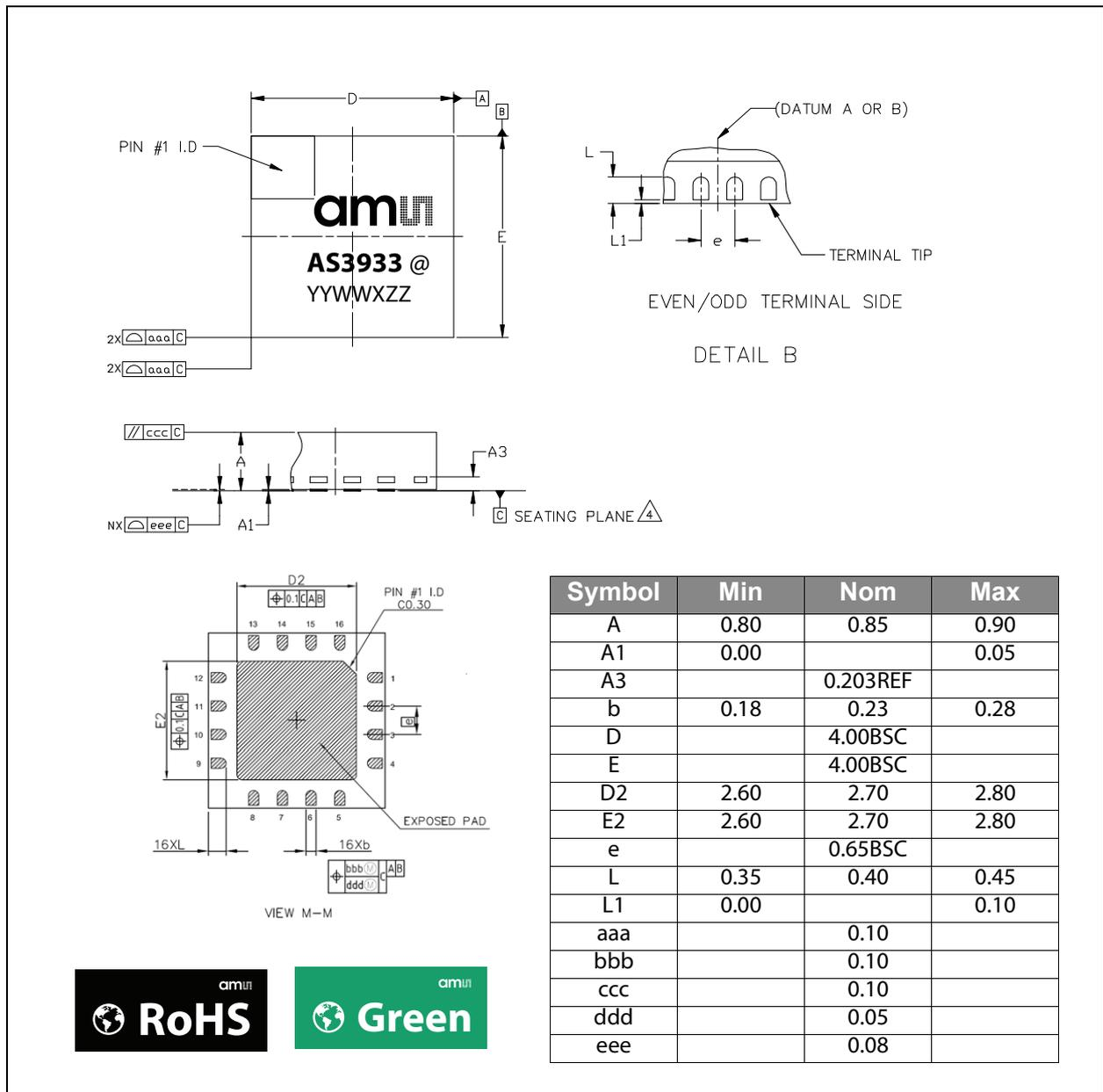
Figure 67:
QFN 4x4 16LD Package Drawing



Note(s) and/or Footnote(s):

1. Dimensions and tolerancing conform to ASME Y14.5M-1994.
2. All dimensions are in millimeters. Angles are in degrees.
3. Dimension b applies to metallized terminal and is measured between 0.25mm and 0.30mm from terminal tip. Dimension L1 represents terminal full back from package edge up to 0.15mm is acceptable.
4. Coplanarity applies to the exposed heat slug as well as the terminal.
5. Radius on terminal is optional.

Figure 68:
Marking: YYWWXZZ@

YY	WW	X	ZZ	@
Year (i.e. 10 for 2010)	Manufacturing Week	Assembly plant identifier	Assembly traceability code	Sublot identifier

Ordering & Contact Information

The devices are available as the standard products shown in Figure 69.

Figure 69:
Ordering Information

Ordering Code	Type	Marking	Delivery Form ⁽¹⁾	Delivery Quantity
AS3933-BTST	16-pin TSSOP	AS3933	7 inches Tape & Reel	1000 pcs/reel
AS3933-BQFT	QFN (4×4) 16LD	AS3933	7 inches Tape & Reel	1000 pcs/reel
AS3933-BSWB	DoW	AS3933	Wafer Box	ca. 8000 dice/wafer

Note(s) and/or Footnote(s):

1. Dry Pack: Moisture Sensitivity Level (MSL) = 3, according to IPC/JEDEC J-STD-033A.

Buy our products or get free samples online at:

www.ams.com/ICdirect

Technical Support is available at:

www.ams.com/Technical-Support

Provide feedback about this document at:

www.ams.com/Document-Feedback

For further information and requests, e-mail us at:

ams_sales@ams.com

For sales offices, distributors and representatives, please visit:

www.ams.com/contact

Headquarters

ams AG
Tobelbaderstrasse 30
8141 Unterpremstaetten
Austria, Europe

Tel: +43 (0) 3136 500 0

Website: www.ams.com

RoHS Compliant & ams Green Statement

RoHS: The term RoHS compliant means that ams AG products fully comply with current RoHS directives. Our semiconductor products do not contain any chemicals for all 6 substance categories, including the requirement that lead not exceed 0.1% by weight in homogeneous materials. Where designed to be soldered at high temperatures, RoHS compliant products are suitable for use in specified lead-free processes.

ams Green (RoHS compliant and no Sb/Br): ams Green defines that in addition to RoHS compliance, our products are free of Bromine (Br) and Antimony (Sb) based flame retardants (Br or Sb do not exceed 0.1% by weight in homogeneous material).

Important Information: The information provided in this statement represents ams AG knowledge and belief as of the date that it is provided. ams AG bases its knowledge and belief on information provided by third parties, and makes no representation or warranty as to the accuracy of such information. Efforts are underway to better integrate information from third parties. ams AG has taken and continues to take reasonable steps to provide representative and accurate information but may not have conducted destructive testing or chemical analysis on incoming materials and chemicals. ams AG and ams AG suppliers consider certain information to be proprietary, and thus CAS numbers and other limited information may not be available for release.

Copyrights & Disclaimer

Copyright ams AG, Tobelbader Strasse 30, 8141 Unterpremstaetten, Austria-Europe. Trademarks Registered. All rights reserved. The material herein may not be reproduced, adapted, merged, translated, stored, or used without the prior written consent of the copyright owner.

Devices sold by ams AG are covered by the warranty and patent indemnification provisions appearing in its General Terms of Trade. ams AG makes no warranty, express, statutory, implied, or by description regarding the information set forth herein. ams AG reserves the right to change specifications and prices at any time and without notice. Therefore, prior to designing this product into a system, it is necessary to check with ams AG for current information. This product is intended for use in commercial applications. Applications requiring extended temperature range, unusual environmental requirements, or high reliability applications, such as military, medical life-support or life-sustaining equipment are specifically not recommended without additional processing by ams AG for each application. This product is provided by ams AG "AS IS" and any express or implied warranties, including, but not limited to the implied warranties of merchantability and fitness for a particular purpose are disclaimed.

ams AG shall not be liable to recipient or any third party for any damages, including but not limited to personal injury, property damage, loss of profits, loss of use, interruption of business or indirect, special, incidental or consequential damages, of any kind, in connection with or arising out of the furnishing, performance or use of the technical data herein. No obligation or liability to recipient or any third party shall arise or flow out of ams AG rendering of technical or other services.

Document Status

Document Status	Product Status	Definition
Product Preview	Pre-Development	Information in this datasheet is based on product ideas in the planning phase of development. All specifications are design goals without any warranty and are subject to change without notice
Preliminary Datasheet	Pre-Production	Information in this datasheet is based on products in the design, validation or qualification phase of development. The performance and parameters shown in this document are preliminary without any warranty and are subject to change without notice
Datasheet	Production	Information in this datasheet is based on products in ramp-up to full production or full production which conform to specifications in accordance with the terms of ams AG standard warranty as given in the General Terms of Trade
Datasheet (discontinued)	Discontinued	Information in this datasheet is based on products which conform to specifications in accordance with the terms of ams AG standard warranty as given in the General Terms of Trade, but these products have been superseded and should not be used for new designs

Revision Information

Changes from 1-07 (2015-Mar-02) to current revision 1-08 (2015-Sep-02)	Page
Updated text under Figure 45	39

Note(s) and/or Footnote(s):

1. Page and figure numbers for the previous version may differ from page and figure numbers in the current revision.
2. Correction of typographical errors is not explicitly mentioned.

Content Guide

1	General Description
1	Key Benefits & Features
2	Applications
5	Pin Assignments
5	TSSOP-16 Package
5	Pin Description
6	QFN-16 Package
7	Pin Description
8	Absolute Maximum Ratings
9	Electrical Characteristics
14	Typical Operating Characteristics
16	Detailed Description
17	Operating Modes
18	Listening Mode
20	Artificial Wake-Up
20	Preamble Detection / Pattern Correlation
20	Data Receiving
21	System and Block Specification
21	Register Table
22	Register Table Description and Default Values
25	Serial Peripheral Interface (SPI)
30	SDI Timing
31	Channel Amplifier and Frequency Detector
31	Frequency Detector / RSSI / Channel Selector
34	Antenna Damper
35	Demodulator / Data Slicer
39	Correlator
39	Pattern: Bit and Symbol Definition in Manchester Code
42	Wake-Up Protocol
43	Wake-Up Protocol: Frequency Detection Only
43	Wake-Up Protocol: Pattern Detection Enabled
46	Manchester Decoder and Clock Recovery
46	False Wake-Up Register
48	Clock Generator
49	Crystal Oscillator
49	RC-Oscillator
51	External Clock Source
52	Antenna Tuning
54	Channel Selection in Scanning Mode and ON/OFF Mode
55	Package Drawings & Markings
57	Ordering & Contact Information
58	RoHS Compliant & ams Green Statement
59	Copyrights & Disclaimer
60	Document Status
61	Revision Information

X-ON Electronics

Largest Supplier of Electrical and Electronic Components

Click to view similar products for [NFC/RFID Tags & Transponders](#) category:

Click to view products by [ScioSense](#) manufacturer:

Other Similar products are found below :

[PNEV512B,699](#) [AT88SC0808CRF-MX1](#) [V680-D1KP54T](#) [V680S-A40 50M](#) [TRPGR30ATGA](#) [P5DF081HN/T1AR1070](#) [SPS1M003B](#)
[SPS1M003A](#) [SPS1M002B](#) [SPS1M002A](#) [V680S-A40 10M](#) [ATA5577M2330C-DBQ](#) [AT88RF04C-MVA1](#) [60208](#) [60170](#)
[P5DF081X0/T1AD2060](#) [MF1S5030XDA8/V1J](#) [MF1S7030XDA4/V1J](#) [HT1MOA4S30/E/3J](#) [HT2MOA4S20/E/3/RJ](#) [MFRC52302HN1,157](#)
[TRPGR30ATGB](#) [NRF51822-QFAA-R](#) [20926410601](#) [CLRC66303HNE](#) [ART915X1620TX16-IC](#) [ART915X2117225TX21-IC](#) [28448](#)
[ART923X1015YZ10-IC](#) [ART868X130903TX13](#) [ART868X25275YZ25](#) [ART915X050503OP-IC](#) [ART915X100202TO-IC](#)
[ART915X100503JA-IC](#) [ART915X130930TX13-IC](#) [ART915X250903AM-IC](#) [ART915X2509EP60-IC](#) [ART915X252503MA-IC](#)
[ART915X25275YZ25](#) [ART915X25275YZ25-IC](#) [ART923X1015YZ10](#) [AS3932-BTST](#) [AS3933-BTST](#) [AT88RF04C-MX1G](#) [20926410802](#)
[LXMSJZNCMF-198](#) [MIKROE-295](#) [MIKROE-779](#) [13356-0571](#) [13356-1151](#)