

编号	SCTF2022LC932
日期	2022-9-19
版本	B01

# 承认书

## SPECIFICATION FOR APPROVAL

客户名称 Customer Name : 立创商城  
\_\_\_\_\_  
供应商物料名称 Part Name : 温度补偿晶体振荡器  
\_\_\_\_\_  
产品描述 Description : TCXO3225 25.000MHz 3.3V ±2.0ppm  
\_\_\_\_\_  
供应商物料料号 Part NO. : SX3T25.000B010J020S  
\_\_\_\_\_  
供应商名称 Supplier Name : 深圳市星通时频电子有限公司  
\_\_\_\_\_

PLEASE CONFIRM OUR SPECIFICATION。 敬请确认规格书之内容。

CUSTOMER APPROVAL 客户审批		
物料代号 PART NO. _____ 使用于机型 USED IN MODEL: _____		
工程部	品质部	采购部

(敬请承认后返回一份, 谢谢!)

SUPPLIER APPROVAL 供应商审批		
DGN. 制表人	CKD. 校对	APPD. 审核 签章
吴丽红	李良	

地址: 深圳市南山区龙珠四路方大城T2栋10楼

Add: 10 / F, Building T2, Fangdacheng, Longzhu 4th Road, Nanshan District, Shenzhen, China.

Website: www.sctf-crystal.com

Email: info@sctf-crystal.com

TEL: 0755-86097430

FAX: 0755-86097259



**产品规格书**  
**SPECIFICATION FOR APPROVAL**

1	Cover 封面.....	Page 1
2	Contents 目录.....	Page 2
3	Revised Page 修改页.....	Page 3
4	Specifications of Oscillator 规格书.....	Page 4
5	Test Circuit & Output Waveform 测试电路与输出波形.....	Page 5
6	Dimensions 尺寸图.....	Page 6
7	Product Structure & Marking 结构与印字.....	Page 7
8	Reflow Profiles 回流焊.....	Page 8
9	Reliability Specification 可靠性测试.....	Page 9
10	Package 包装.....	Page 10

SHENZHEN SCTF ELECTRONICS CO. , LTD		
DATE	Temperature Compensated Crystal Oscillators 温度补偿晶体振荡器规格书	PAGE
2022-9-19	P/N: SX3T25.000B010J020S Spec. NO. : SCTF2022LC932	2

### 3 Revised Page

Rev.	Revise page	Revise Contents	Date	Ref. No.	Reviser
1	N/A	Initial released	2022-9-19	N/A	吴丽红

<b>SHENZHEN SCTF ELECTRONICS CO. , LTD</b>		
<b>DATE</b>	Temperature Compensated Crystal Oscillators 温补石英晶体振荡器规格书	<b>PAGE</b>
2022-9-19	P/N: SX3T25.000B010J020S Spec. NO. : SCTF2022LC932	3

# 4 QUARTZ CRYSTAL UNIT SPECIFICATION

## ■ Electrical Specification 电气参数

No.	Item	Symb.	Electrical spec.	Unit	Notes
1	Holder Type 封装		SMD 3225		
2	Nominal Frequency 标称频率	Fo	25.000000	MHz	
3	Supply Voltage 供电电压	Vcc	3.3	V	±5% Max.
4	Frequency Tolerance 初始频差	Fo_tol	±1.0	ppm	T <sub>use</sub> =25±2℃
5	Frequency Vs Temperature Change 频率-温度特性	Fo_Tc	±2.0	ppm	T <sub>use</sub> = -30℃~+85℃ (Based on frequency at +25℃)
6	Frequency vs Load Change 频率-负载特性	Fo_Load	±0.2 Max.	ppm	±10% load change
7	Frequency vs Voltage Change 频率-电压特性	Fo_Vcc	±0.2 Max.	ppm	Voltage varied ±5% at 25℃
8	Supply Current 功耗	Icc	2.0 Max.	mA	At maximum supply voltage
9	Output Waveform 输出波形		Clipped sine wave		DC Coupled clipped sine wave
10	Output Level 输出电平	Vp-p	0.8 Min.	V	
11	Duty cycle 点空比		40~60	%	Ground level
12	Harmonics 谐波		-5.0 Max.	dBc	
13	Load 输出负载	Load	10KΩ//10pF		
14	Start Time 起振时间	S-T	2.0 Max.	ms	
15	Phase Noise 相位噪声		-130	dBc/Hz	Offset: 1KHz
			-152		Offset: 100KHz
16	Operating Temperature Range 工作温度范围	T <sub>use</sub>	-30~+85	℃	
17	Storage Temperature Range 存储温度范围	T <sub>stg</sub>	-40~+105	℃	
18	Aging 老化	f <sub>age</sub>	±1.0	ppm	First year at 25℃
19	Others 其他	ROHS			

## SHENZHEN SCTF ELECTRONICS CO., LTD

DATE	Temperature Compensated Crystal Oscillators 温度补偿晶体振荡器规格书	PAGE
2022-9-19	P/N: SX3T25.000B010J020S Spec. NO. : SCTF2022LC932	4

## 5 TEST CIRCUIT、OUTPUT WAVEFORM

### ■ TESTING CIRCUIT 测试电路

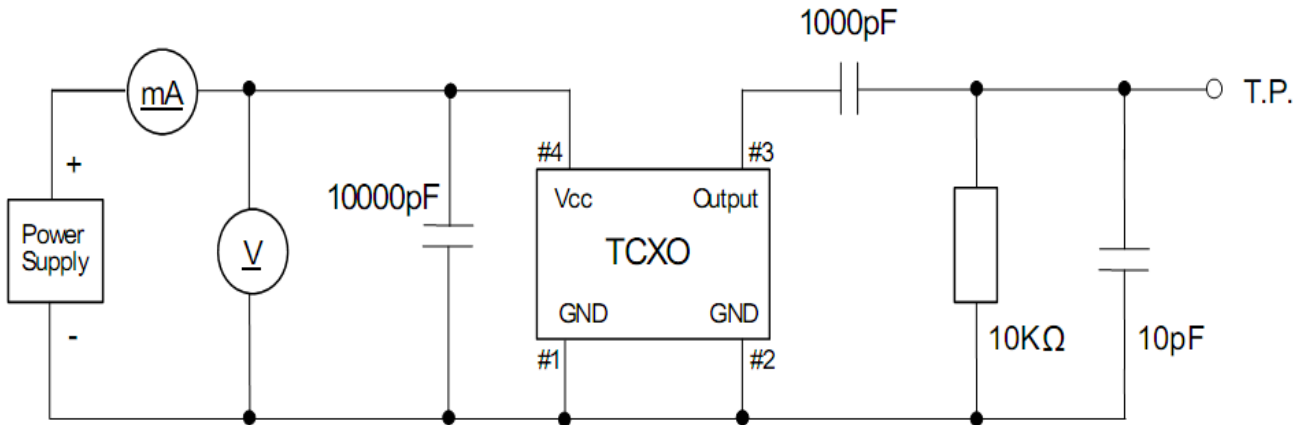

### ■ WAVEFORM CONDITIONS 输出波形

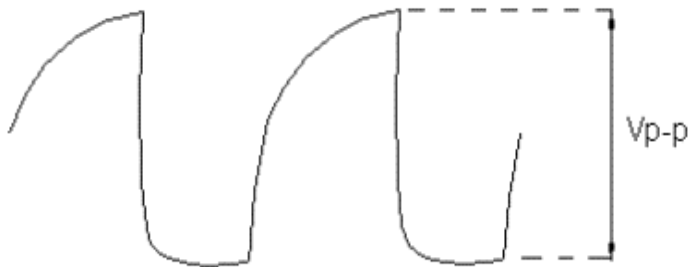

SHENZHEN SCTF ELECTRONICS CO. , LTD

DATE	Temperature Compensated Crystal Oscillators 温度补偿晶体振荡器规格书	PAGE
2022-9-19	P/N: SX3T25.000B010J020S Spec. NO. : SCTF2022LC932	5

# 6 DIMENSIONS

## ■ DIMENSIONS 产品尺寸

Units (单位): mm(毫米)

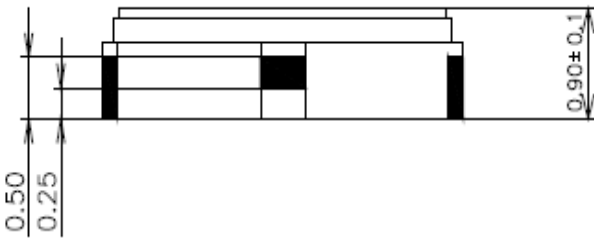
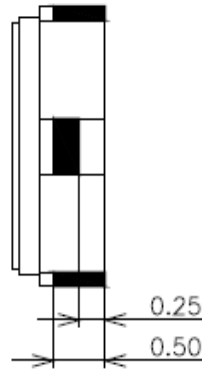
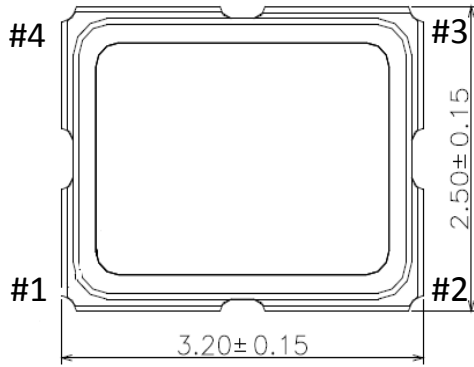

### Pin Connections

Pin No.	Connection
#1	GND
#2	GND
#3	Output
#4	V <sub>CC</sub>

## ■ Pad size 焊盘尺寸

Bottom view

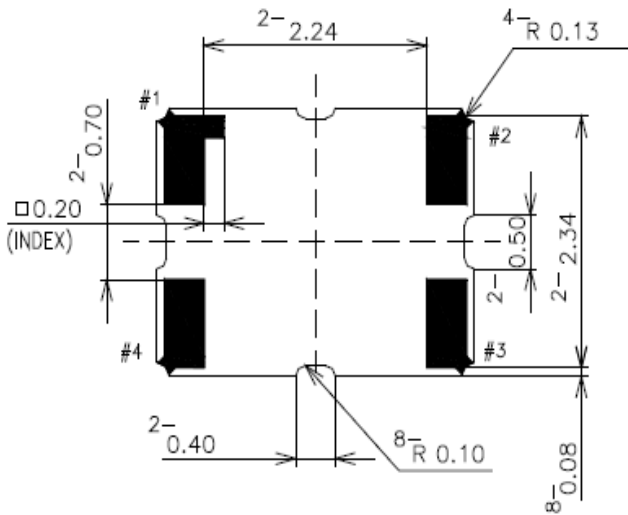

Suggested solder pad layout

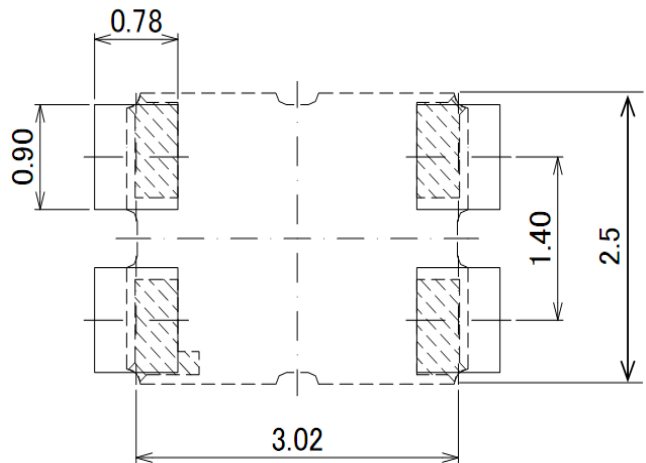

## SHENZHEN SCTF ELECTRONICS CO., LTD

DATE	Temperature Compensated Crystal Oscillators 温度补偿晶体振荡器规格书	PAGE
2022-9-19	P/N: SX3T25.000B010J020S Spec. NO. : SCTF2022LC932	6

# 7 PRODUCT STRUCTURE & MARKING

## ■ Product Structure 产品结构

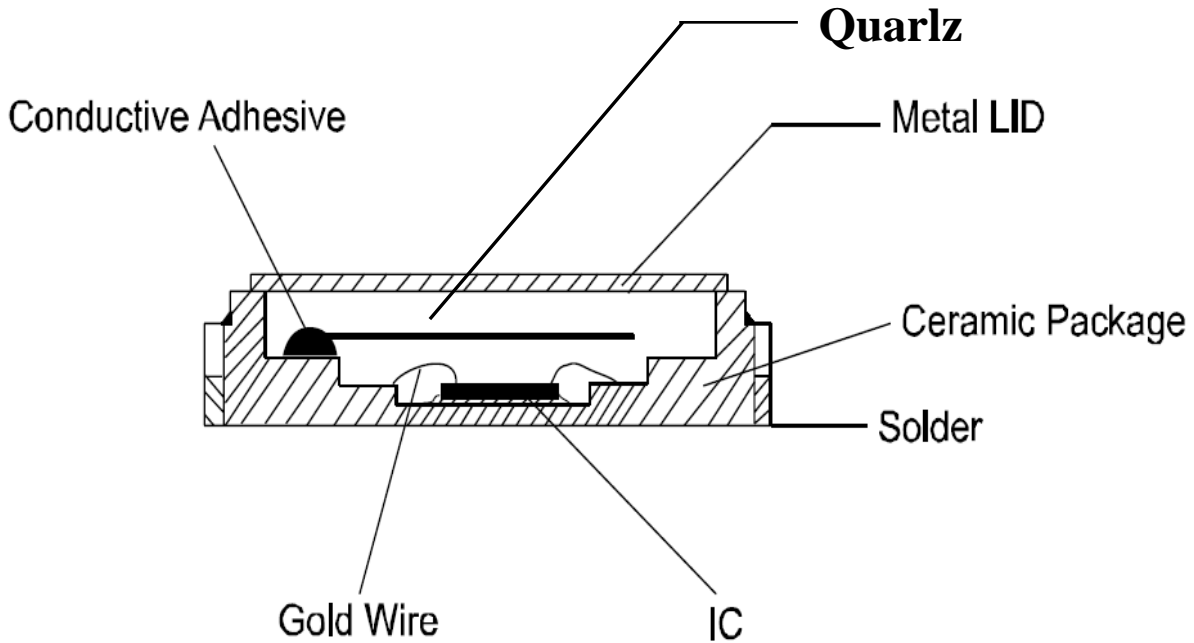

## ■ Marking 印字

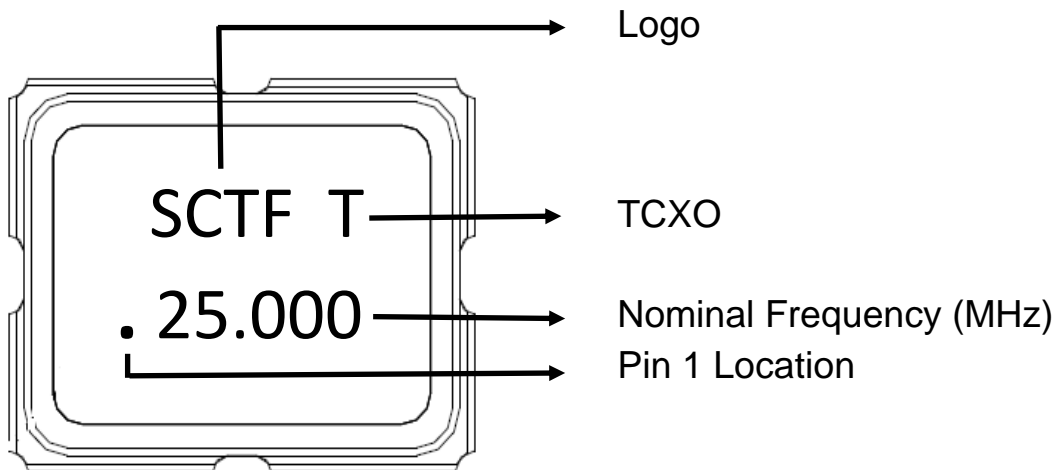

<b>SHENZHEN SCTF ELECTRONICS CO. , LTD</b>		
<b>DATE</b>	Temperature Compensated Crystal Oscillators 温度补偿晶体振荡器规格书	<b>PAGE</b>
2022-9-19	P/N: SX3T25.000B010J020S Spec. NO. : SCTF2022LC932	7

## 8 REFLOW PROFILES

### REFLOW PROFILES 回流焊条件

Profile Feature	Sn-Pb Eutectic Assembly	Pb-Free Assembly
Preheat/Soak		
● Temperature Min( $T_s$ min)	100 °C	150 °C
● Temperature Max ( $T_s$ max)	150 °C	200 °C
● Time ( $T_s$ min to $T_s$ max)	60-120 seconds	60-120 seconds
Ramp-up rate (TL to $T_p$ )	3 °C/second max.	3 °C/second max.
Time maintained above		
● Liquidous temperature (TL)	183 °C	217 °C
● Time ( $t_L$ ) maintained above TL	60-150 seconds	60-150 seconds
Peak package body temperature ( $T_p$ )	235°C	260°C
Time within 5 °C of the specified classification temperature ( $T_p$ )	20 seconds	30 seconds
Ramp-down rate ( $T_p$ to TL)	6 °C/second max.	6 °C/second max.
Time 25 °C to peak temperature	6 minutes max.	8 minutes max.
<b>Suggest reflow times</b>	<b>2 Times max.</b>	

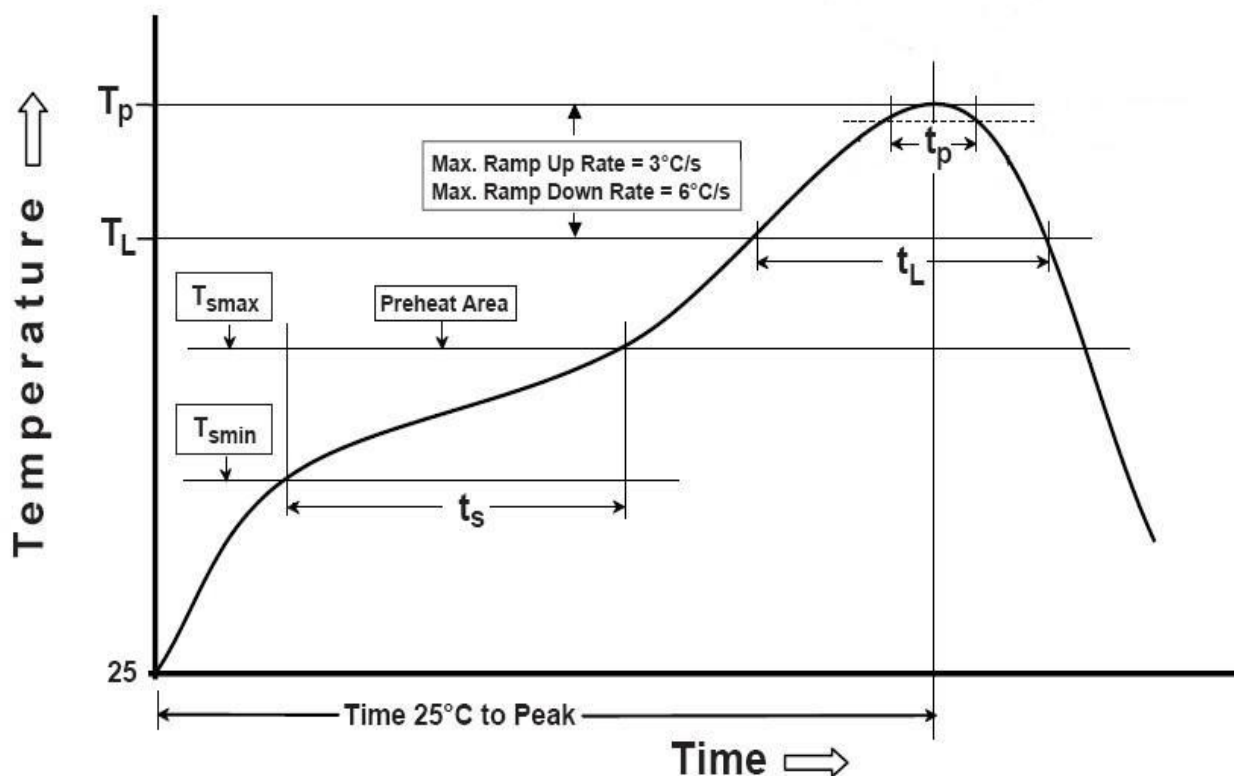

SHENZHEN SCTF ELECTRONICS CO., LTD

DATE	Temperature Compensated Crystal Oscillators 温度补偿晶体振荡器规格书	PAGE
2022-9-19	P/N: SX3T25.000B010J020S Spec. NO. : SCTF2022LC932	8



## 9 RELIABILITY SPECIFICATION

### ■ Environmental and mechanical characteristics 可靠性参数

No.	Item	Value *1		Test method
		Freq. Tolerance [1×10 <sup>-6</sup> ] *2	Electrical characteristics	
1	High temp. storage *3	± 2.0	Satisfy Item output level after test	+85 °C × 1 000 h
2	Low temp. storage *3	± 2.0		-40 °C × 1 000 h
3	High temperature with Humidity	± 2.0		+85 ± 2 °C × 85 ± 5 %RH × 1 000 h
4	Temp. cycle *3	± 2.0		-40 °C to +85 °C (30 min × 100 cycle/each)
5	Resistance to Soldering heat (Reflow characteristics)	± 1.0		Reflow furnace with the condition 2 times
6	Drop	± 2.0		Free drop from 750 mm height on a hard wooden board for 3 times. (Board is thickness more than 30 mm)
7	Vibration (variable frequency)	± 1.0		10 Hz to 55 Hz 0.75 mm 55 Hz to 500 Hz acceleration 98 m/s <sup>2</sup> 10 Hz → 500 Hz → 10 Hz 15 min./cycle 6 h(2 h × 3 directions)
8	ESD (MM)	± 1.0		200pF 0Ω 200V. Discharge 3 pulses
9	ESD (HBM)	± 1.0		100pF 1.5kΩ 2000V. Discharge 3 pulses
10	Solderability	Terminals must be 95 % covered with fresh solder		Dip termination into solder bath at +235 °C for 5 s (Using Rosin Flux)

#### Notes

- 1.\*1 each test is independent.
- 2.\*2 measuring 2 h to 24 h later leaving in room temperature after each test.
- 3.\*3 Pre conditionings
  1. reflow 2 times
  2. Initial value shall be after 24 h at room temperature.

<b>SHENZHEN SCTF ELECTRONICS CO. , LTD</b>		
<b>DATE</b>	Temperature Compensated Crystal Oscillators 温度补偿晶体振荡器规格书	PAGE
2022-9-19	P/N: SX3T25.000B010J020S Spec. NO. : SCTF2022LC932	9

# 10 PACKAGE

## ■ Taping Specifications 编带

UNIT(单位):mm(毫米)

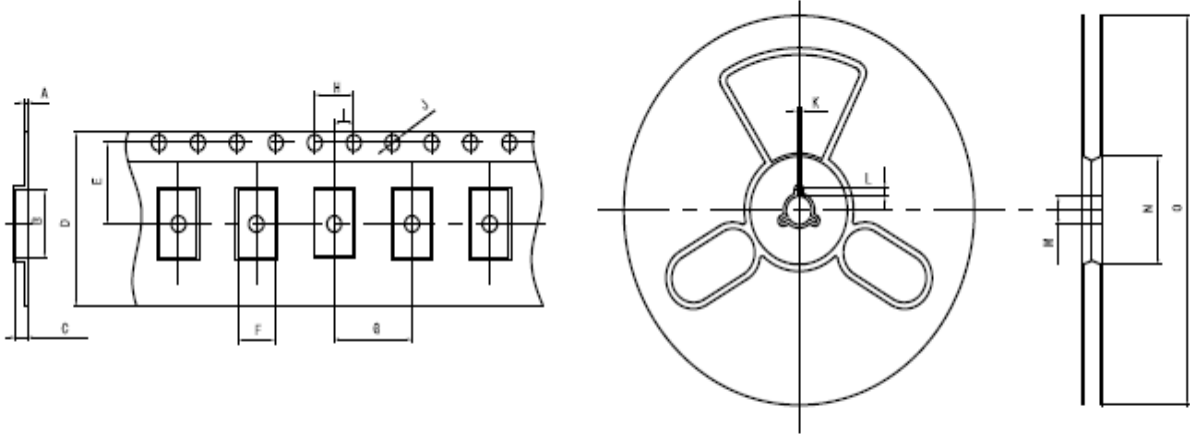

TEYE	A	B	C	D	E	F	G	H	I	J	K	L	M	N	O
3.2×2.5 SMD	0.25	3.6	1.3	8	3.5	2.9	4	4	2	1.5	2	4	13	50	180

## ■ Packaging specifications 包装

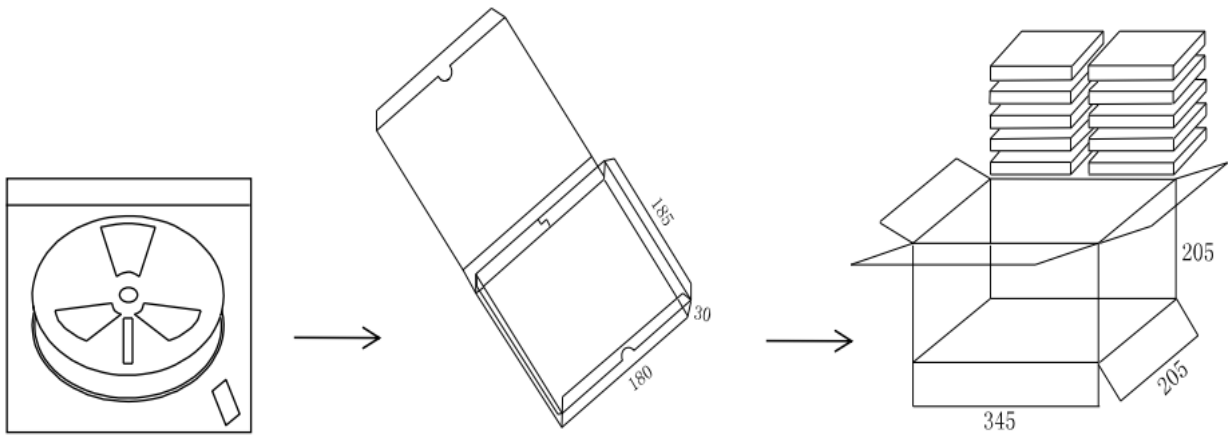

自封袋(Bag)  
3000只 = 1 轮  
3000pcs = 1 Reel

内包装(Inside package)  
1 轮=1 盒  
1 Reel=1 box

外包装(Outside Package )  
10 盒=1 箱  
10 box=1 carton

### SHENZHEN SCTF ELECTRONICS CO. , LTD

DATE	Temperature Compensated Crystal Oscillators 温度补偿晶体振荡器规格书	PAGE
2022-9-19	P/N: SX3T25.000B010J020S Spec. NO. : SCTF2022LC932	10

## X-ON Electronics

Largest Supplier of Electrical and Electronic Components

*Click to view similar products for [TCXO Oscillators](#) category:*

*Click to view products by [SCTF](#) manufacturer:*

Other Similar products are found below :

[AST3TQ-40.000MHZ-5](#) [SIT5000ACC8E-33VQ-19.200000X](#) [SiT5001AI-2E-33N0-48.000000X](#) [TG3225CEN 25.0000M-KFGNNAB](#)  
[SIT5001AI-2E-33N0-24.000000x](#) [SIT1566AC-JV-18E-32.768E](#) [AST3TDATAACJ5-10.0000MHz](#) [AST3TDATAACJ5-20.0000MHz](#)  
[AST3TDA53TACJ2-38.8800MHz](#) [AST3TDATAACJ5-38.8800MHz](#) [NT0503CC3I287EN10](#) [NT0503CH3I287CN25](#) [NT0503CH3I287CN30.72](#)  
[NT0503CC3I287DN20](#) [TG-3541CE 32.7680KXB0](#) [KT1612A26000AAW18TBL](#) [KT1612A26000AAW18NBL](#) [TG-5006CG-12H 26.0000M0](#)  
[TG2520SMN 38.4000M-MCGNNM3](#) [X1G004131000900](#) [X1G0041310042](#) [1XXC26000PKA](#) [X1G005441030316](#) [X1G005441020616](#)  
[X1G005441030416](#) [X1G005421020416](#) [X1G005441020316](#) [7L26002007](#) [1XTV12800MDA](#) [X1G005421031215](#) [X1G005421020516](#)  
[SX1T19.200B010J020S](#) [T132S4-25000ML33DTL](#) [X1G0053710200](#) [NT0503CH3I287EN10](#) [8153H-50.000LH33DTL](#) [NT0503EH3I106EN10](#)  
[NT0507BH3I107BN40](#) [NT0503CH3I207EN10](#) [NT0507BH3I507EA10](#) [BT0507BC3I287CN38.4B](#) [NT0507BH3I106BA50](#)  
[NT0503CH3I507CN24.576](#) [OW2EL89CENUXFMYLC-16M](#) [OW2EL89CENUXFMYLC-32M](#) [OW2EL89CENUXFMYLC-24M](#)  
[OW7EL89CENUYO3YLC-24M](#) [OW3EL89CENUNFAYLC-26M](#) [OW7EL89CENUYO3YLC-20M](#) [OW7EL89CENUNFAYLC-52M](#)