



Modify Record:

版次	新版本	旧版本	修改单位	修改内容
2019-06-01	1.0	NA	研发部	新文件制成（因工程产品，故 RD 开头）
2020-06-11	1.1	1.0	研发部	增加典型应用电路图
2020-06-24	1.2	1.1	研发部	增加 EMSOP8 封装
2020-07-31	1.3	1.2	研发部	增加应用信息，增加EN 耐压信息
2020-08-17	1.4	1.3	研发部	更新典型应用电路、增加PSRR
2020-09-28	1.5	1.4	研发部	增加SOP8脚位图
2020-11-06	1.6	1.5	研发部	增加T0252脚位图
2021-08-05	1.7	1.6	研发部	增加SOT89-3导电胶脚位图

General Description (产品描述)

SE86XX series is designed for power-sensitive applications. It includes a precision and high voltage input stage, an ultra-low-power bias current branch, and results in a ultra-low-power and low-dropout linear regulator.

The SE86XX operates from an input voltage of $V_{OUT}+1V$ to 65V, consumes only 1.8 μ A of quiescent current, and offers 1% initial accuracy and low dropout voltage, 70mV typical at 10mA.

SE86XX is a fixed output LDO with available has available voltages at 3.3V and 5.0V.

Although designed primarily as fixed voltage regulators, the device can be used with external resistors to obtain variable output voltages. The typical such application circuit, along with the needed calculations for accurate output voltages, are attached on the following page.

Other features include short-circuit protection and thermal shutdown.

Features(产品特性)

- Ultra Low Quiescent Current: 1.8uA(Typ.)
- Wide Operating Voltage: $V_{OUT}+1V$ to 65V (max V_{in} can be up to 80V)
- High output current: $\geq 200mA$
- System startup with no overshoot
- Short circuit protection is designed with no overshoot
- Low Dropout Voltages:
 - 70mV@10mA
 - 700mV@100mA
- High Accuracy Output Voltage: $\pm 2\%$
 - Accuracy can be 1% for special orders
- Excellent power / load transient response
- Low temperature coefficient: $\pm 100ppm/^{\circ}C$
- Thermal and Short-Circuit Protection
- With EN pin
- Available Packages: SOT23-3, SOT23-5, SOT89, EMSOP8, SOP8, TO252

Applications(产品应用)

- Battery-powered equipment
- Smoke detector and sensor
- Microcontroller Applications
- Smart electric meter



Typical Application (典型应用电路)

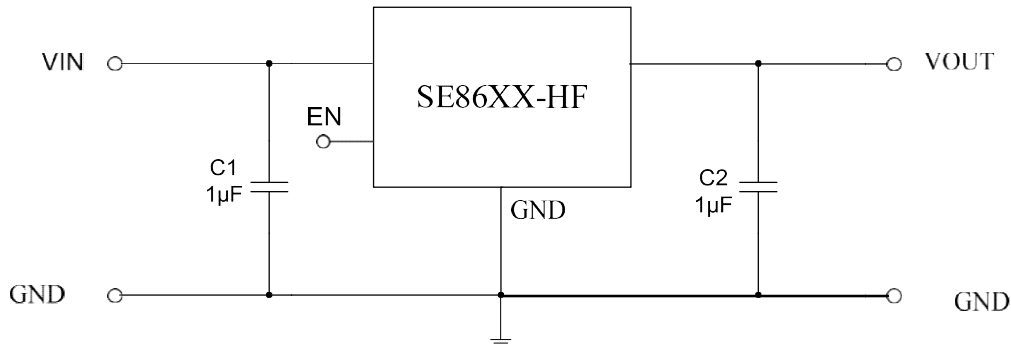

Pin Configuration (管脚排列)

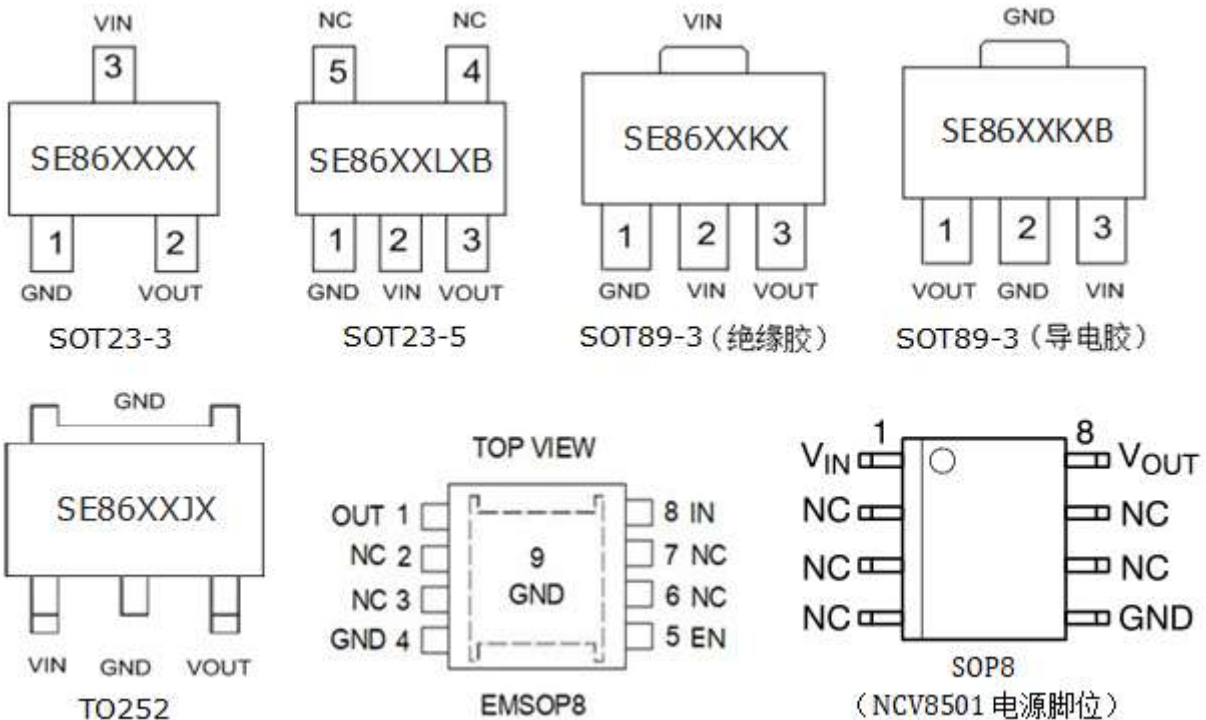

注：芯片上对应的标识为成品名称，只作为下单参考。

Pin Description (管脚功能描述)

Pin Name	Pin Function Description
VIN	In put pin
VOUT	Out put pin
GND	Ground pin
EN	Enable pin
NC	No connection



Functional Block Diagram (功能框图)

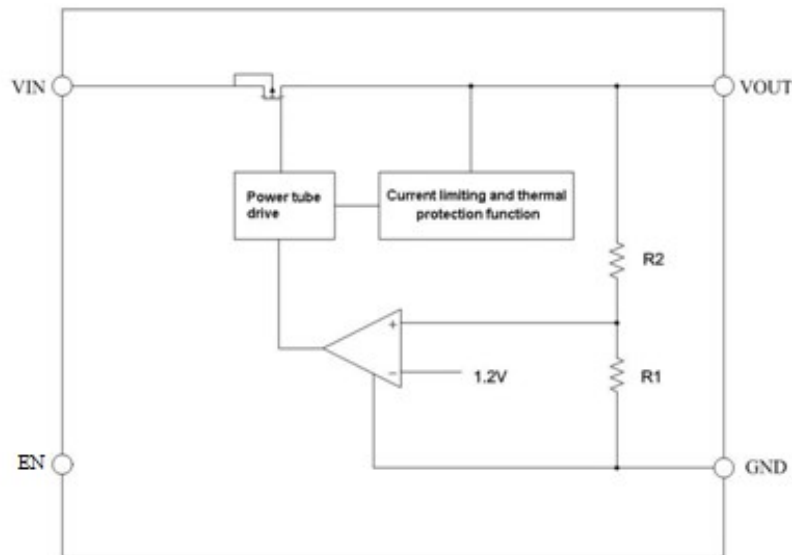

Ordering Information (订货信息)

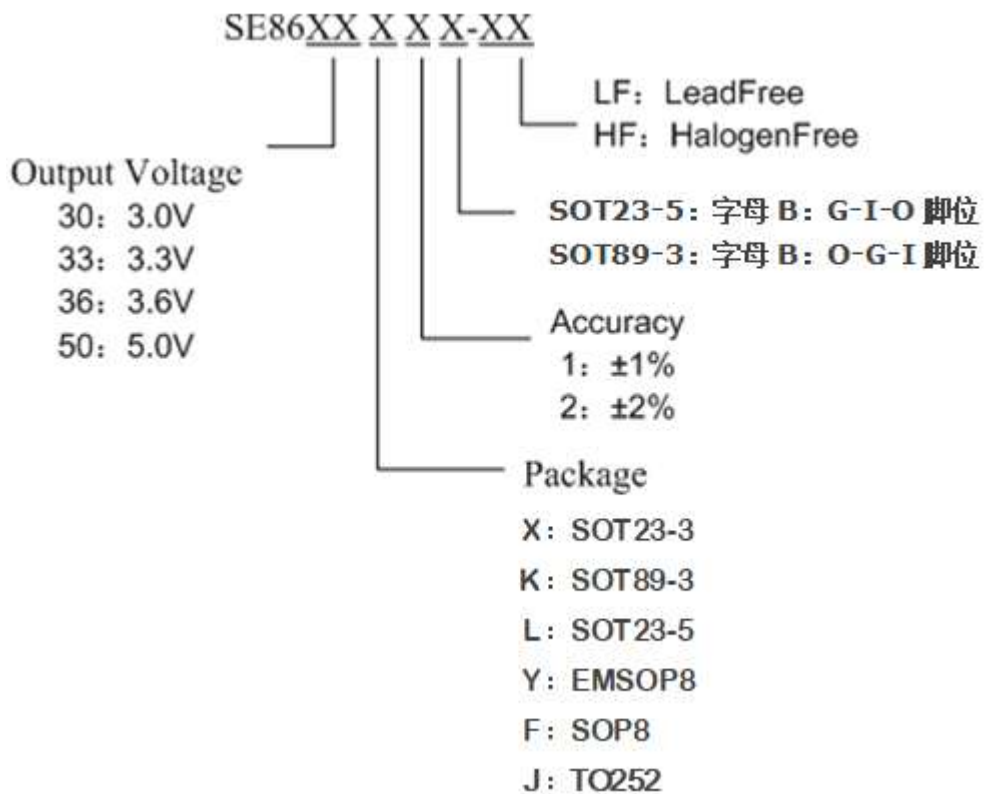



Absolute Maximum Ratings(最大额定参数)

Symbol	Parameter	Value	Units
V_{IN}	Input Supply Voltage	80	V
EN	Enable Voltage	80	
$V_{OUT} - GND$	Output Voltage TO GND	6	
$V_{out} - V_{IN}$	Output Voltage TO V_{IN}	-75	
T_A	Operating Temperature	-40---105	°C
T_{STG}	Storage Temperature	-40---150	
T_J	Maximum Junction Temperature	150	
T_{LEAD}	Lead Temperature (Soldering) 10 seconds	260	
θ_{JA}	Thermal Resistance, Junction-to-Ambient	165(SOT89)	°C/W
		280(SOT23-3)	
		270(SOT23-5)	
		180(SOP8)	
		85(TO252)	
P_D	Power Consumption	750(SOT89)	mW
		446(SOT23-3)	
		465(SOT23-5)	
		700(SOP8)	
		1300(TO252)	
Electrostatic discharge rating	Human Body Model (HBM)	4	kV
	Charged Device Model (MM)	100	V

Note : Stresses exceeding the range specified under “Absolute Maximum Ratings” may cause substantial damage to the device. Functional operation of this device at other conditions beyond those listed in the specification is not implied and prolonged exposure to extreme conditions may affect device reliability.

Recommended Operating Conditions(推荐工作条件)

Symbol	Parameter	Maximum	Units
V_{IN}	Input Supply Voltage	60	V
T_A	Operating Temperature	-20---85	°C
T_{LEAD}	Lead Temperature (Soldering) 10 seconds	260	°C



Electrical Characteristics(电气参数)

(TA=25° C, CIN=1uF, VIN=VOUT+1.0V, COUT=10uF, unless otherwise noted)

Symbol	Parameter	Conditions	Min	Typ	Max	Unit
V _{IN}	Input Supply Voltage		2.8		60	V
V _{OUT}	Output Voltage Accuracy	I _{OUT} =10mA	-1%		1%	V
			-2%		2%	V
I _Q	Quiescent Current	V _{IN} =6V~60V		1.8	4	μA
I _{OUT}	Output Current			200		mA
V _{DROP}	Dropout Voltage	I _{OUT} =10mA ΔV _{OUT} = - V _{OUT} *2%		70		mV
		I _{OUT} =100mA ΔV _{OUT} = - V _{OUT} *2%		700		mV
V _{LR}	Load Regulation	1mA ≤ I _{OUT} ≤ 100mA		20		mV
V _{SR}	Line Regulation	I _{OUT} =1mA, V _{IN} =(V _{OUT} +1V) to 60V		0.2		%/V
PSRR	Power Supply Rejection Ratio	V _{in} =12V , I _{out} =10mA F=1KHz, V _{out} =3.3V	—	70	—	dB
V _{ENH}	Enable High Level	Enabled	1	—	—	V
V _{ENL}	Enable Low Level	Disabled		—	0.4	V
I _{EN}	EN Current	EN=0~V _{IN} (R _{EN} =100K)		1		μA
I _{LIMIT}	Current Limit			250		mA
T _{SHDN}	Thermal Protection			150		°C
TC _{VOUT}	Output Voltage Temperature Coefficient	I _{OUT} =10mA -40°C ≤ T _{AMB} ≤ 100°C		-17		ppm/°C



Typical Performance Characteristics(典型性能特性)

(TA=25° C, CIN=1uF, VIN=VOUT (3.3V) +1.0V, COUT=10uF, unless otherwise noted)

Output Voltage vs Temperature

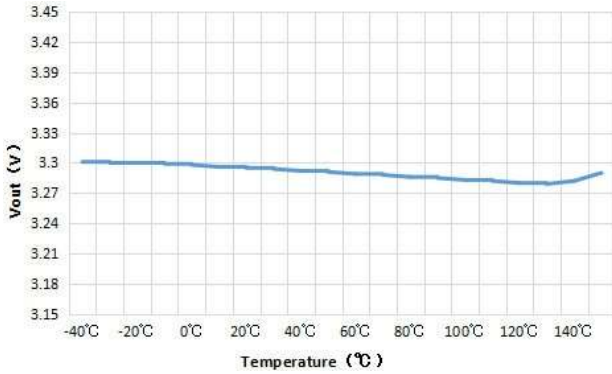

Quiescent current vs Input Voltage

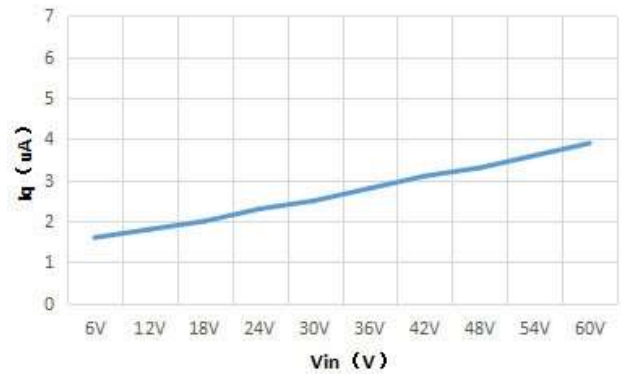

Load Regulation (Vin=30V)

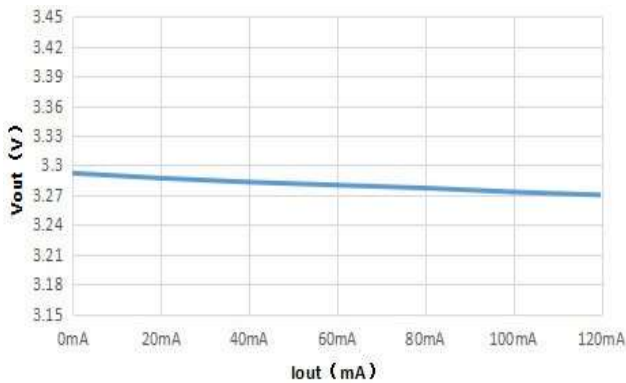

Line Regulation

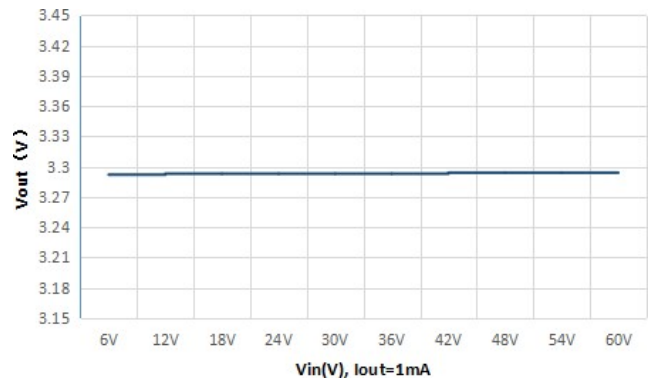

Power-Supply Rejection Ratio vs. Frequency

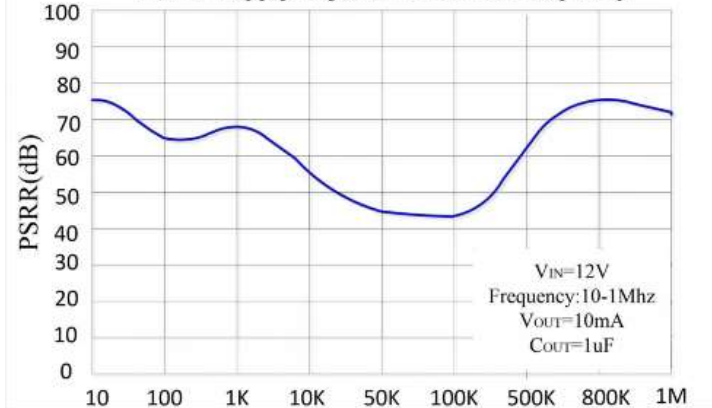



Load Transient ($V_{in}=12V$)
10mA~100mA

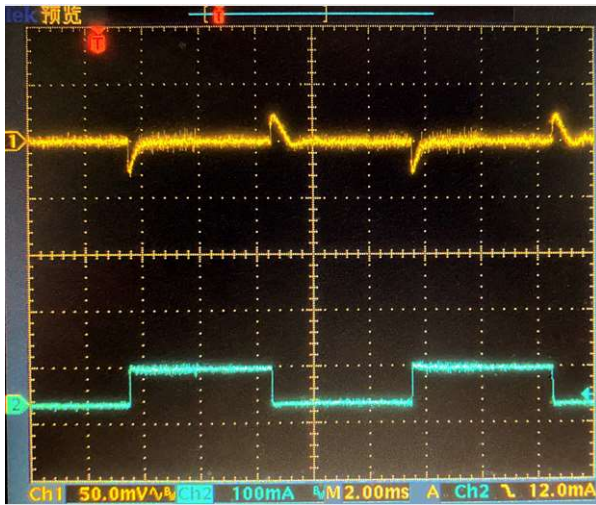

Short-Circuit and OTP ($V_{in}=24V$)

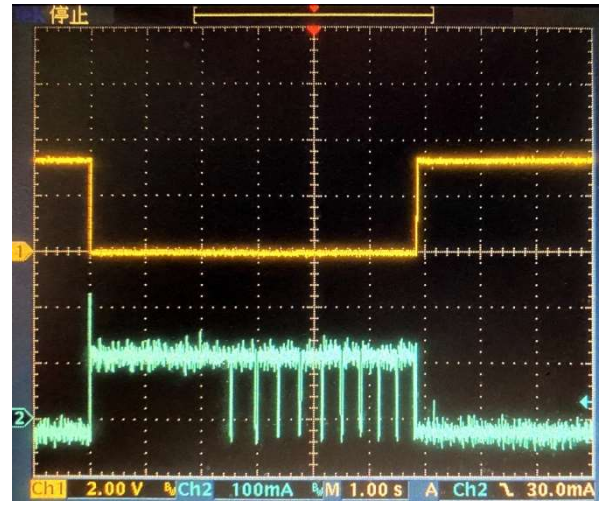

EN OFF → ON

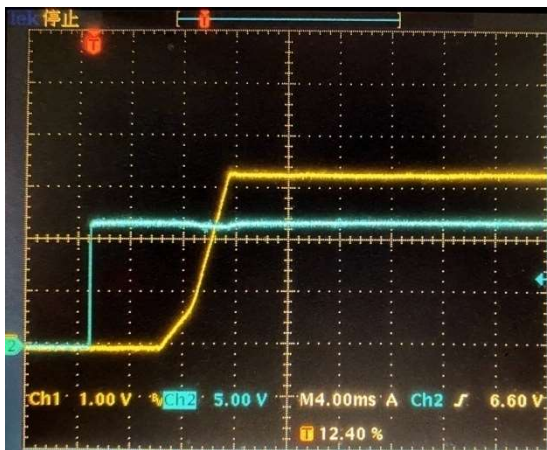

EN ON → OFF (No Load)
Discharge

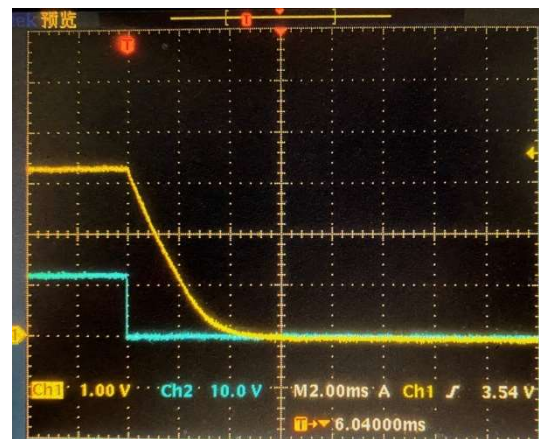

VCC Power ON

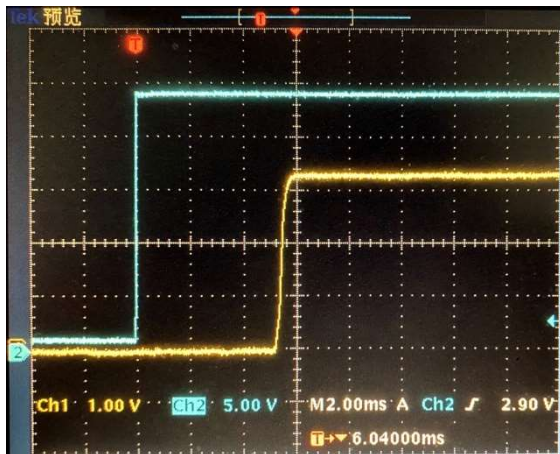

APPLICATION INFORMATION

INPUT CAPACITOR

An input ceramic capacitor of 1 μ F is required between the VIN and GND pin. The capacitor shall be placed as close as possible to VIN pin, and the wide copper trace is also recommended.

OUTPUT CAPACITOR

The recommended is 10 μ F ceramic capacitor. The minimum capacitance for stable and correct operation is 1 μ F. The higher the value of this output capacitor, the lower the ripple during the operations. The output capacitor should be placed as close to the Output Pin as possible. The wide copper trace is recommended.

NO-LOAD STABILITY

The SE86XX will remain stable and in regulation with no external load.

FOLD-BACK SHORT-CIRCUIT PROTECTION

When short-circuit occurs, SE86XX will fold back the short-circuit currents to a pre-determined lower level, This will reduce excessive heat in otherwise large current conditions. This feature provides another level of protection to IC itself and also the whole system.

EN Functions

EN is Hi-Z internally. EN must be connected to either to Vcc (through a resistor) or GND externally, if SOT23-5 package is used. If left floating, the Vout is unknown.

IN-RUSH CURRENT AND VOLTAGE

The following figure shows a typical application circuit for the SE86XX devices. Please keep in mind that in-rush current can push up the Vin overshoot by as much as 50%. For example, when Vin=50V, the in-rush caused spike voltage can be as high as 75V. Therefore the voltage rating of Cin needs to be higher than 50% of the application.

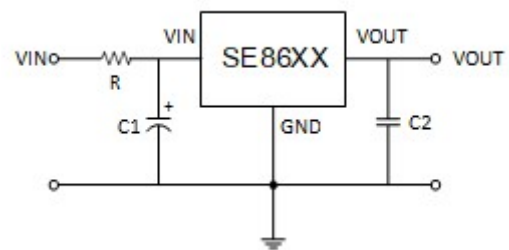

In live insertion application, it is suggested that R, C1 are selected as following:

- 1.C1=10 μ F ~ 100 μ F ceramic or electrolytic capacitor with maximum voltage greater than 80V, R=0
2. If the average current is known, for example at 10mA, then for an input voltage of 55V, the C1=1 μ F ~ 10 μ F ceramic or electrolytic with maximum voltage greater than 80V and R=2K Ω in the type of 1206 at 1/4W rating can be selected.



Outline Drawing for SOT-23-3

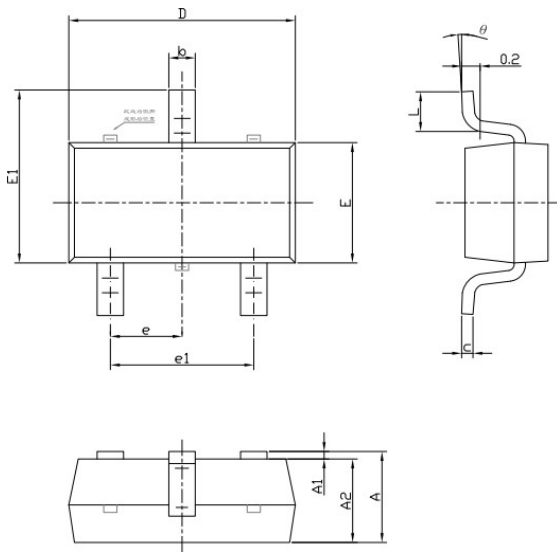

Symbol	Dimensions In Millimeters		Dimensions In Inches	
	Min	Max	Min	Max
A	1.050	1.250	0.041	0.049
A1	0.000	0.100	0.000	0.004
A2	1.050	1.150	0.041	0.045
b	0.300	0.500	0.012	0.020
c	0.100	0.200	0.004	0.008
D	2.820	3.020	0.111	0.119
E	1.500	1.700	0.059	0.067
E1	2.650	2.950	0.104	0.116
e	0.950(BSC)		0.037(BSC)	
e1	1.800	2.000	0.071	0.079
L	0.300	0.600	0.012	0.024
θ	0°	8°	0°	8°

Outline Drawing for SOT-23-5

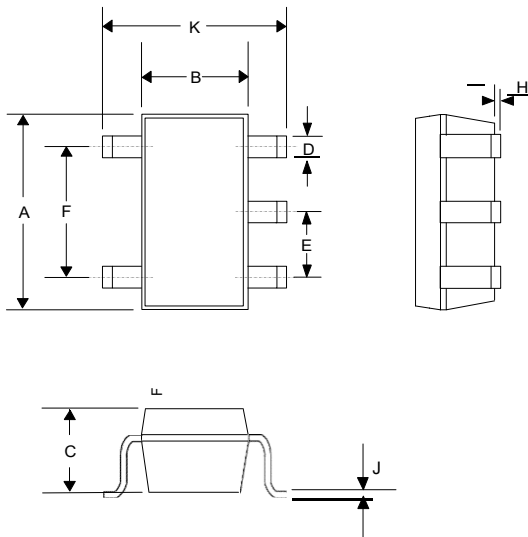

DIMENSIONS				
DIM ^N	INCHES		MM	
	MIN	MAX	MIN	MAX
A	0.110	0.120	2.80	3.05
B	0.059	0.070	1.50	1.75
C	0.036	0.051	0.90	1.30
D	0.014	0.020	0.35	0.50
E	-	0.037	-	0.95
F	-	0.075	-	1.90
H	-	0.006	-	0.15
J	0.0035	0.008	0.090	0.20
K	0.102	0.118	2.60	3.00



Outline Drawing for SOT-89

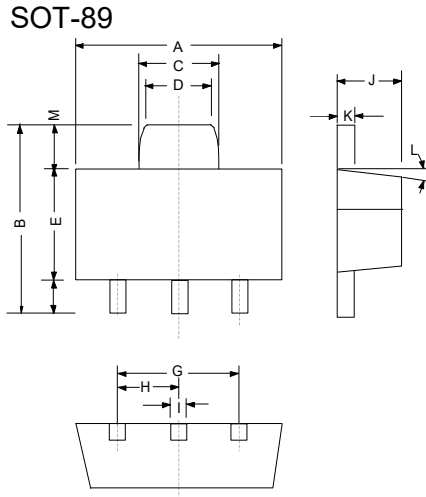

DIMENSIONS				
DIM ^N	INCHES		M M	
	MIN	MAX	MIN	MAX
A	0.173	0.181	4.400	4.600
B	0.159	0.167	4.050	4.250
C	0.067	0.075	1.700	1.900
D	0.051	0.059	1.300	1.500
E	0.094	0.102	2.400	2.600
F	0.035	0.047	0.890	1.200
G	0.118REF		3.00 REF	
H	0.059REF		1.50 REF	
I	0.016	0.020	0.400	0.520
J	0.055	0.063	1.400	1.600
K	0.014	0.016	0.350	0.410
L	10 °TYP		10 °TYP	
M	0.028REF		0.70 REF	

Outline Drawing for EMSOP8

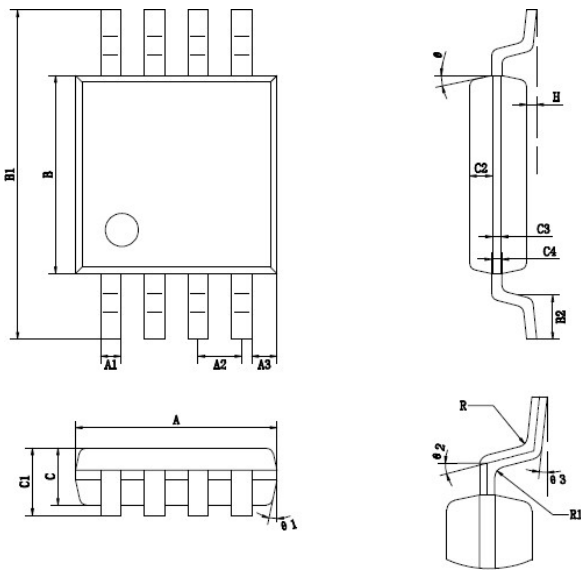

标注	尺寸	最小(mm)	最大(mm)	标注	尺寸	最小(mm)	最大(mm)
A		2.90	3.10	C3		0.152	
A1		0.30TYP		C4		0.172	
A2		0.65TYP		H		0.02	0.15
A3		0.375TYP		θ		12° TYP4	
B		2.90	3.10	θ1		12° TYP4	
B1		4.70	5.10	θ2		14° TYP	
B2		0.50	0.70	θ3		0° ~ 6°	
C		0.75	0.95	R		0.15TYP	
C1		--	1.10	R1		0.15TYP	
C2		0.37					

Outline Drawing for SOP8

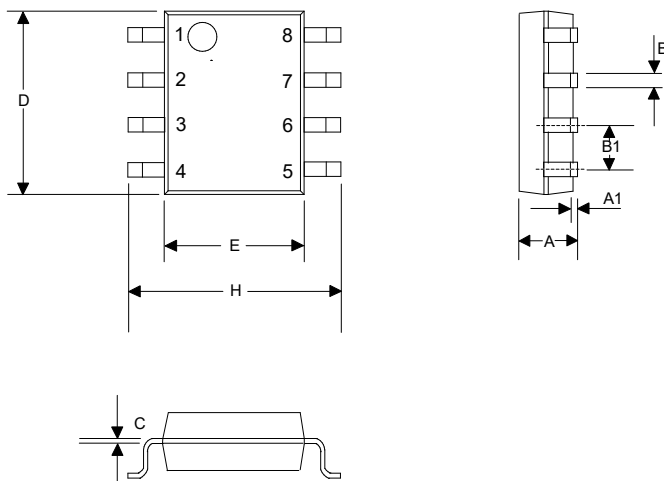

DIMENSIONS				
DIM ^N	INCHES		MM	
	MIN	MAX	MIN	MAX
A	0.0532	0.0688	1.35	1.75
A1	0.0040	0.0098	0.10	0.25
B	0.0130	0.0200	0.33	0.51
B1	0.050 BSC		1.27 BSC	
C	0.0075	0.0098	0.19	0.25
D	0.1890	0.1968	4.80	5.00
H	0.2284	0.2440	5.80	6.20
E	0.1497	0.1574	3.80	4.00

Outline Drawing for TO252

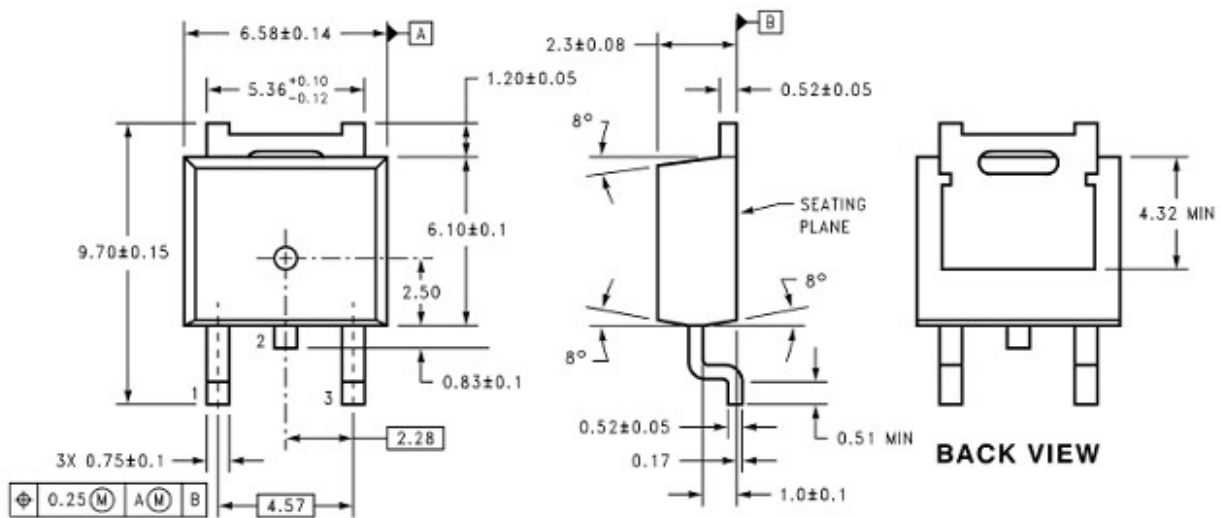

DIMENSIONS ARE IN MILLIMETERS

3-Lead TO-252 Package



SEAWARD
ELECTRONICS

SE86XX

80V/2uA,Ultra Low Quiescent Current LDO

联系方式:

北京思旺电子有限公司-中国总部

地址: 中国北京市海淀区信息路 22 号上地科技综合楼 B 座二层

邮编: 100085

电话: 010-82895700/1/5

传真: 010-82895706

邮箱: sales@seawardinc.com.cn

Seaward Electronics Incorporated – 北美办事处

1512 Centre Pointe Dr.

Milpitas, CA95035, USA

电话: 1-650-444-0713

X-ON Electronics

Largest Supplier of Electrical and Electronic Components

Click to view similar products for [Linear Voltage Regulators](#) category:

Click to view products by [Seaward](#) manufacturer:

Other Similar products are found below :

[LV5684PVD-XH](#) [MCDTSA6-2R](#) [L7815ACV-DG](#) [LV56801P-E](#) [UA7805CKC](#) [714954EB](#) [ZMR500QFTA](#) [BA033LBSG2-TR](#)

[NCV78M05ABDTRKG](#) [LV5680P-E](#) [L79M05T-E](#) [L78LR05D-MA-E](#) [NCV317MBTG](#) [NTE7227](#) [MP2018GZD-33-P](#) [MP2018GZD-5-P](#)

[LV5680NPVC-XH](#) [ZTS6538SE](#) [UA78L09CLP](#) [UA78L09CLPR](#) [CAT6221-PPTD-GT3](#) [MC78M09CDTRK](#) [NCV51190MNTAG](#)

[BL1118CS8TR1833](#) [BL8563CKETR18](#) [BL8077CKETR33](#) [BL9153-33CC3TR](#) [BL9161G-15BADRN](#) [BL9161G-28BADRN](#)

[BRCO7530MMC](#) [CJ7815B-TFN-ARG](#) [LM317C](#) [GM7333K](#) [GM7350K](#) [XC6206P332MR](#) [HT7533](#) [LM7912S/TR](#) [LT1764S/TR](#) [LM7805T](#)

[LM338T](#) [LM1117IMP-3.3/TR](#) [HT1117AM-3.3](#) [HT7550S](#) [AMS1117-3.3](#) [HT7150S](#) [78L12](#) [HT7550](#) [HT7533-1](#) [HXY6206I-2.5](#) [HT7133](#)