

## General Description

SE100 is designed to support QuickCharge QC 2.0 (QC2.0) specifications. It is a low-cost solution to support QC2.0 functions. SE100 incorporates all necessary functions to add QC2.0 capability to standard Adaptor designs, Portable Battery designs, and Car-charger designs.

SE100 supports the full output voltage range of either Class A or Class B. Optionally Class B can be inhibited for protecting the battery charger from accidental damage.

SE100 automatically detects whether a connected Powered Device (PD) is QC2.0 capable before enabling output voltage adjustment. If a PD that is not compliant to QC2.0 is detected the SE100 disables output voltage adjustment to ensure safe operation with legacy 5 V only USB PDs.

## Pin Configuration

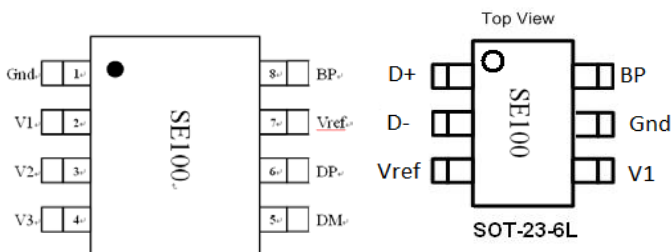

## Features

- Fully supports Quick Charge 2.0 specification
- Class A: 5 V, 9 V, and 12 V output voltage
- Class B: 5 V, 9 V, 12 V, and 20 V output voltage
- USB battery charging specification revision 1.2 compatible
- Automatic USB DCP shorting D+ to D- line
- Default 5 V mode operation
- Very low power consumption
- Less than 1 mW at 5 V output
- Fail safe operation
- Adjacent pin-to-pin short-circuit fault
- Open circuit pin fault

## Applications

- Adaptors for smart phones, tablets, netbooks, digital cameras, and bluetooth accessories
- Portable Battery Packs supporting QC.20 functions
- Car Chargers supporting QC2.0 functions
- Ogther USB power output ports supporting QC2.0 functions



## Typical Application

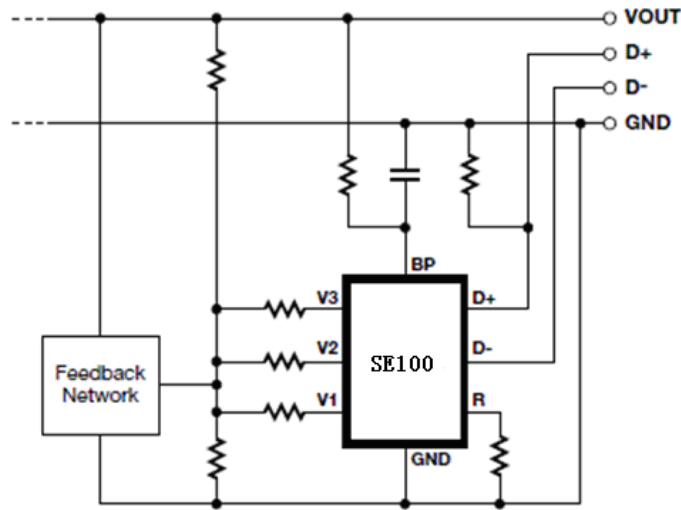

## Pin Description

NO.	Pin Name	Pin Function Description
1	GND	Ground
2	V1	Open Drain input of output voltage adjustment switch. Active for 9 V, 12 V, and 20 V output setting.
3	V2	Open Drain input of output voltage adjustment switch. Active for 12 V, and 20 V output setting.
4	V3	Open Drain input of output voltage adjustment switch. Active for 20 V output setting.
5	D-	USB D- data line input.
6	D+	USB D+ data line input.
7	R	Connected to internal band-gap reference. Provides reference current through connected resistor.
8	BP	Connection point for an external bypass capacitor for the internally generated supply voltage.



## Functional Block Diagram

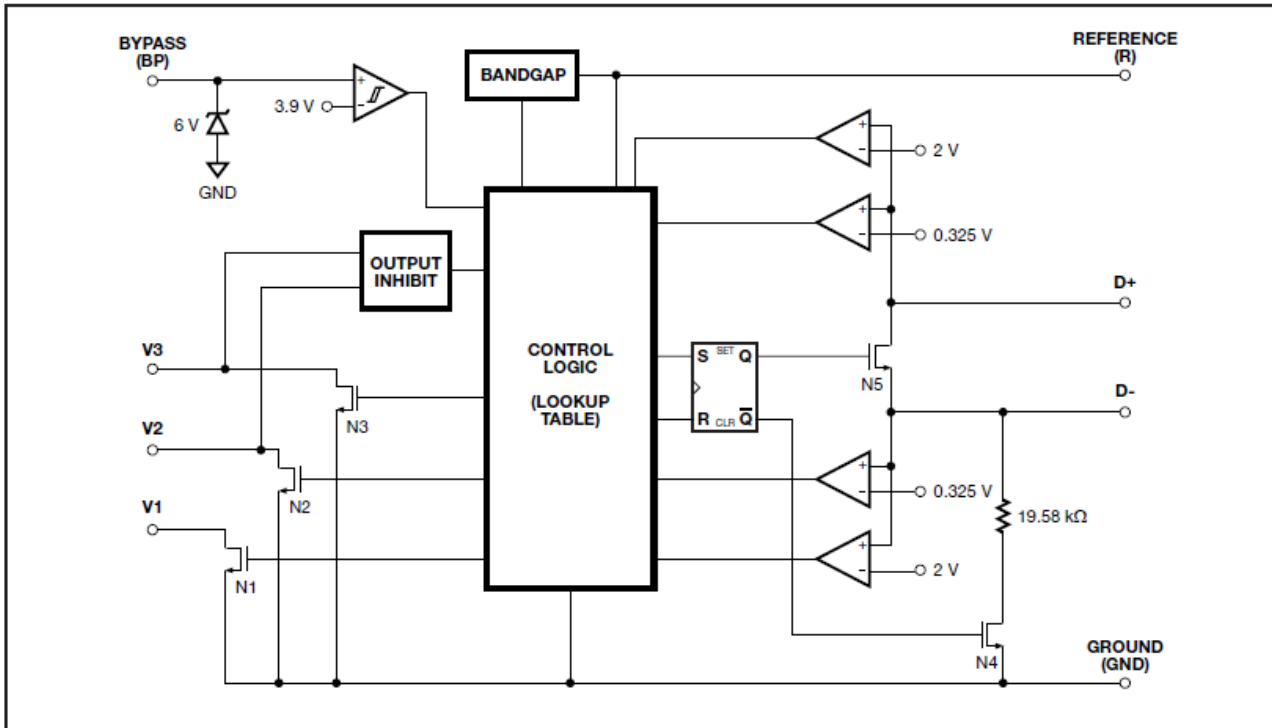

## Absolute Maximum Ratings

Symbol	Parameter	Maximum	Units
$V_{BP}$	BYPASS Pin Voltage	5.6	V
$V_R$	REFERENCE Pin Voltage	5	V
$V_{V1/V2/V3}$	V1/V2/V3 Pin Voltage	$V_{BP}$	V
$V_{D+/D-}$	D+/D- Pin Voltage	5	V
$I_{BP}$	BYPASS Pin Current	15	mA
$I_{V1/V2/V3}$	V1/V2/V3 Pin Current	0.5	mA
$I_{D+/D-}$	D+/D- Pin Current	1	mA

Note:  $V_{V1/V2/V3}$  电压不能大于  $V_{BP}$

## Recommended Operating Conditions



Symbol	Parameter	Maximum	Units
T <sub>J</sub>	Operating Junction Temperature	-20 to 125	°C
T <sub>A</sub>	Operating Ambient Temperature	-20 to 85	°C
T <sub>s</sub>	Storage Temperature	-65 to 150	°C
	Lead Temperature (less than 15 seconds)	260	°C

**Electrical Characteristics** (V<sub>CC</sub>=5V; T<sub>J</sub>=25°C unless otherwise specified)

Symbol	Parameter	Test Conditions	Min	Typ	Max	Unit
V <sub>BP</sub>	BYPASS Pin Voltage		4	5		V
V <sub>BP (reset)</sub>	Power-Up Reset Threshold Voltage		3.8			V
I <sub>BPSC</sub>	BYPASS Pin Source Current	V <sub>BP</sub> = 4.3 V, T <sub>J</sub> = 25 °C, N1 = N2 = N3 = Off		140		μA
I <sub>BP(SHUNT)</sub>	BYPASS Pin Shunt Voltage	I <sub>BP</sub> =3mA	5.0	5.3	5.6	V
V <sub>R</sub>	REFERENCE Pin Voltage		1.22	1.27	1.32	V
V <sub>DAT(REF)</sub>	Data Detect Voltage			0.325		V
V <sub>SEL(REF)</sub>	Output Voltage Selection Reference			2		V
V <sub>INH</sub>	12 V / 20 V Output Inhibit Threshold		V <sub>BP</sub> -0.8			V
I <sub>DAT(SHORT)</sub>	Data Lines Short-Circuit Delay	V <sub>OUT</sub> ≥ 0.8 V		18		μs
T <sub>GLITCH</sub>	D+ High Glitch Filter Time			1250		ms
T <sub>GLITCH(V) CHANGE</sub>	Output Voltage Glitch Filter Time			32		ms
R <sub>DM(DWN)</sub>	D- Pull-Down Resistance			19.53		Ω
R <sub>D(S)ON1</sub>	Switch N1 On-Resistance	I <sub>N1</sub> =200μA			300	Ω
R <sub>D(S)ON2</sub>	Switch N2 On-Resistance	I <sub>N2</sub> =200μA			300	Ω
R <sub>D(S)ON3</sub>	Switch N3 On-Resistance	I <sub>N3</sub> =200μA			300	Ω
R <sub>D(S)ON4</sub>	Switch N4 On-Resistance	I <sub>N4</sub> =200μA			300	Ω
R <sub>D(S)N5</sub>	Switch N5 On-Resistance	I <sub>N1</sub> =200 μ A, V <sub>D+</sub> ≤ 3.6V			40	Ω



Typical Performance Characteristics

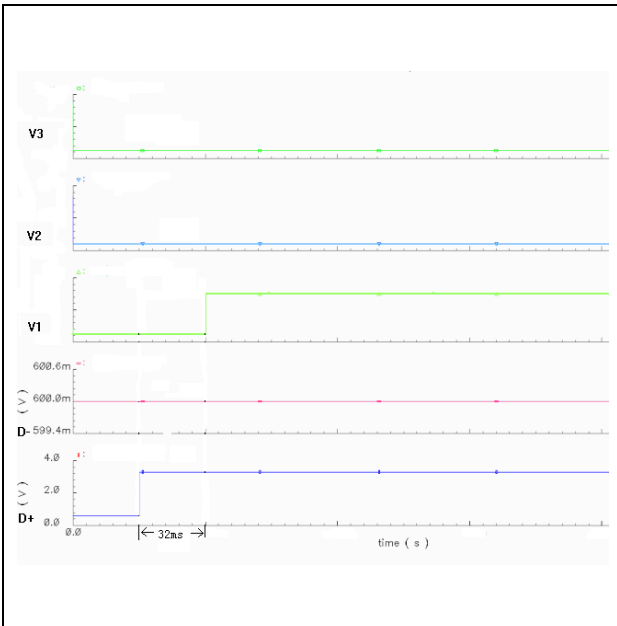

握手完成后, D+, D-输入 0.6V; D+由 0.6V 升到 3.3V, V1 打开

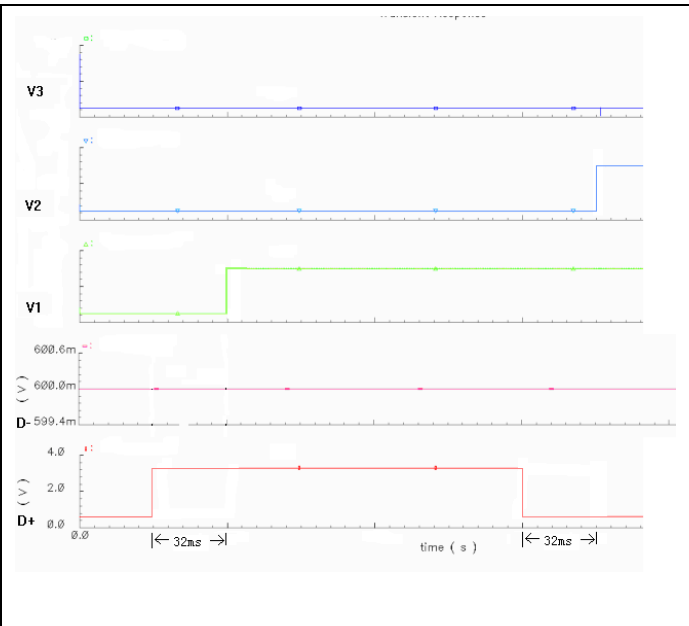

握手完成后, D+, D-输入 0.6V; D+由 0.6 升到 3.3V, V1 打开, D+由 3.3V 下降到 0.6V, V1/V2 打开

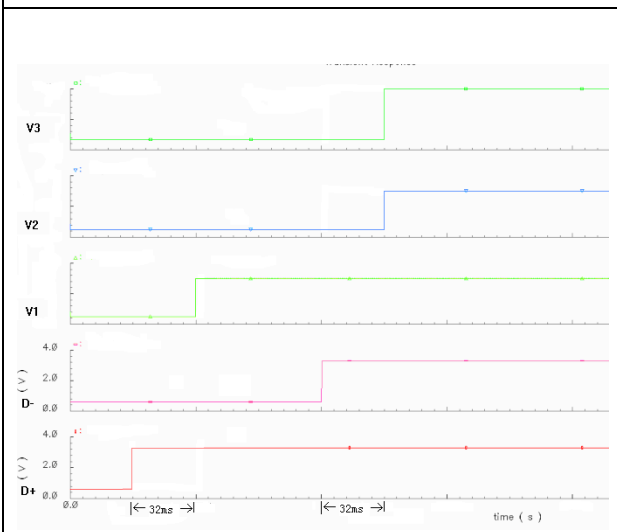

握手完成后, D+, D-输入 0.6V; D+由 0.6 升到 3.3V, V1 打开, D-由 0.6 升到 3.3V, V1/V2/V3 打开

D+	D-	Output	Switch Status
0.6 V	0.6 V	12 V	N1 = N2 = On, N3 = Off
3.3 V	0.6 V	9 V	N1 = On, N2 = N3 = Off
3.3 V	3.3 V	20 V	N1 = N2 = N3 = On
0.6 V	GND	5 V (default)	N1 = N2 = N3 = Off

## Applications Information

SE100 is a low-cost USB high-voltage dedicated charging port interface IC for the Quick Charge 2.0 specification. It incorporates all necessary functions to add Quick Charge 2.0 capability to standard Adaptors, Car-chargers, and Portable Battery Packs.

SE100 also supports other solutions with traditional feedback schemes like opto-coupler and secondary reference regulator SE431 as depicted in Figure 1.

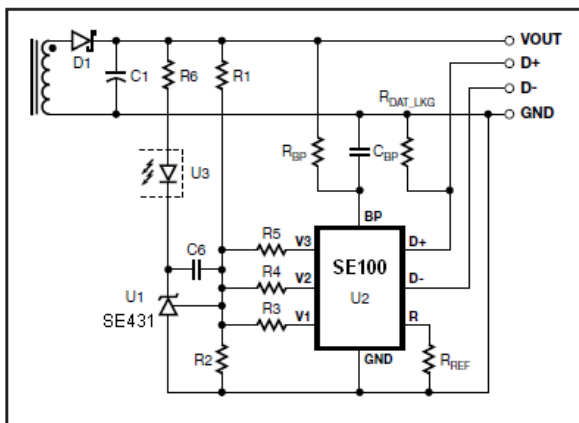

Figure 1. SE100 with Traditional Output Regulation (CV Only).

SE100 supports the full output voltage range of Quick Charge 2.0 Class A (5 V, 9 V, or 12 V) or Class B (5 V, 9 V, 12 V, or 20 V). It automatically detects either Quick Charge 2.0 capable powered devices (PD) or legacy PDs compliant with the USB Battery Charging Specification revision 1.2 and only enables output voltage adjustment accordingly.

### Shunt Regulator

The internal shunt regulator clamps the BYPASS pin at 6 V when current is provided through an external resistor ( $R_{BP}$  in Figure 1). This facilitates powering of SE100 externally over the wide power supply output voltage range of 5 V to 20 V. Recommended values are  $R_{BP} = 4.7 \text{ k}\Omega$  and  $C_{BP} = 220 \text{ nF}$ .

### BYPASS Pin Undervoltage

The BYPASS pin undervoltage circuitry resets the SE100 when the BYPASS pin voltage drops below 3.9 V. Once the BYPASS pin voltage drops below 3.9 V it must rise back to 4 V to enable correct operation.

### Reference Input

Resistor  $R_{REF}$  at the REFERENCE pin is connected to an internal band gap reference and provides an accurate reference current for internal timing circuits. The recommended value is  $R_{REF} = 127 \text{ k}\Omega$ .

### Quick Charge 2.0 Interface

At power-up SE100 turns on switch N5 (see Figure 3) in 20 ms or less after the BYPASS pin voltage has reached 4 V. Switch N4 and output switches N1 to N3 remain off. This sets the default 5 V output voltage level. With D+ and D- short-circuited the normal handshake between the AC-DC adapter (DCP) and powered devices (PD) as described in the USB Battery Charging Specification 1.2 can commence. After switch N5 has been turned on SE100 starts monitoring the voltage level at D+.

At USB cable disconnect the voltage level at D+



above  $V_{DAT(REF)}$  (typ. 0.325 V) and below  $V_{SEL(REF)}$  (typ. 2 V) for at least 1.25 seconds SE100 will enter Quick Charge 2.0 operation mode. If the voltage at D+ drops any time below 0.325 V SE100 resets the 1.25 seconds timer and stays in USB Battery Charging Specification 1.2 compatibility mode with a default output voltage of 5 V.

Once SE100 has entered Quick Charge 2.0 operation mode switch N5 will be turned off. Additionally switch N4 is turned on connecting a 19.53 kΩ pull-down resistor to D-. As soon as the voltage at D- has dropped low (<0.325 V) for at least 1 ms SE100 starts accepting requests for different AC-DC adapter output voltages by means of applied voltage levels at data lines D+ and D- through the powered device. Table 1 summarizes the output voltage lookup table, corresponding AC-DC adapter output voltages and status of switches N1 to N3.

D+	D-	Output	Switch Status
0.6 V	0.6 V	12 V	N1 = N2 = On, N3 = Off
3.3 V	0.6 V	9 V	N1 = On, N2 = N3 = Off
3.3 V	3.3 V	20 V	N1 = N2 = N3 = On
0.6 V	GND	5 V (default)	N1 = N2 = N3 = Off

For Quick Charge 2.0 Class A support only, the V3 pin has to be connected to the BYPASS pin (directly or through a resistor up to 100 kΩ). This will inhibit any requests for setting a 20 V output.

is pulled down by resistor  $R_{DAT(LKG)}$  (see Figure 1). Once it drops below 0.325 V SE100 will turn on switch N5 (thereby short-circuiting D+ and D-) and turns off switches N1 to N4. This sets the default output voltage of 5 V. The recommended value for  $R_{DAT(LKG)} = 390\text{ k}\Omega$ .

$$V_{o1}(5V) = V_{FB} * ((R_1/R_2) + 1);$$

$$V_{o2}(9V) = V_{FB} * ((R_1/R_{X1}) + 1), R_{X1} = R_2 // R_3;$$

$$V_{o3}(12V) = V_{FB} * ((R_1/R_{X2}) + 1), R_{X2} = R_{X1} // R_4;$$

$$V_{o4}(20V) = V_{FB} * ((R_1/R_{X3}) + 1), R_{X3} = R_{X2} // R_5;$$



**OUTLINE DRAWING SOP-8**

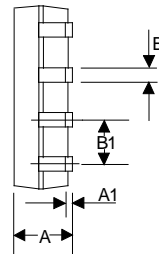
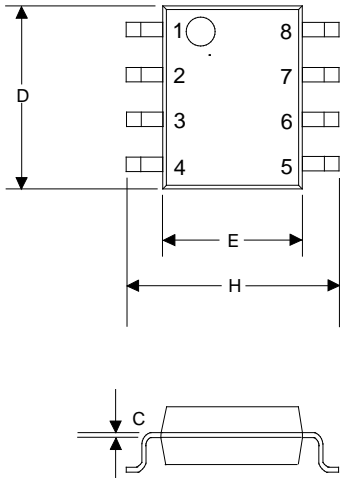

DIMENSIONS				
DIM <sup>N</sup>	INCHES		MM	
	MIN	MAX	MIN	MAX
A	0.0532	0.0688	1.35	1.75
A1	0.0040	0.0098	0.10	0.25
B	0.0130	0.0200	0.33	0.51
B1	0.050 BSC		1.27 BSC	
C	0.0075	0.0098	0.19	0.25
D	0.1890	0.1968	4.80	5.00
H	0.2284	0.2440	5.80	6.20
E	0.1497	0.1574	3.80	4.00

**OUTLINE DRAWING SOT-23-6L**

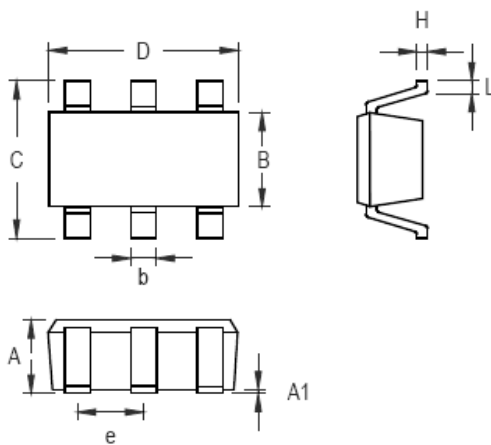

Symbol	Dimensions In Millimeters		Dimensions In Inches	
	Min	Max	Min	Max
A	0.889	1.295	0.031	0.051
A1	0.000	0.152	0.000	0.006
B	1.397	1.803	0.055	0.071
b	0.250	0.560	0.010	0.022
C	2.591	2.997	0.102	0.118
D	2.692	3.099	0.106	0.122
e	0.838	1.041	0.033	0.041
H	0.080	0.254	0.003	0.010
L	0.300	0.610	0.012	0.024





**联系方式:**

北京思旺电子有限公司-中国总部

地址: 中国北京市海淀区信息路 22 号上地科技综合楼 B 座二层

邮编: 100085

电话:010-82895700/1/5

传真:010-82895706

Seaward Electronics Corporation – 台湾办事处

2F, #181, Sec. 3, Minquan East Rd,

Taipei, Taiwan R.O.C

电话: 886-2-2712-0307

传真: 886-2-2712-0191

Seaward Electronics Incorporated – 北美办事处

1512 Centre Pointe Dr.

Milpitas, CA95035, USA

电话: 1-408-821-6600

## X-ON Electronics

Largest Supplier of Electrical and Electronic Components

*Click to view similar products for [USB Interface IC](#) category:*

*Click to view products by [Seaward](#) manufacturer:*

Other Similar products are found below :

[CY7C65210-24LTXI](#) [CY7C69356-48LTXC](#) [CYUSB2304-68LTXI](#) [CYPD2119-24LQXI](#) [USB2227-NU-11](#) [USB3319C-GJ-TR](#) [USB3370B-EZK-TR](#) [PTN5150AHXMP](#) [CY7C65215A-32LTXI](#) [CYPD2120-24LQXI](#) [CYWB0164BB-BZXI](#) [CYWB0224ABS-BZXI](#) [CY7C65211A-24LTXI](#) [USB3803CI-1-GL-TR](#) [USB2422T-I/MJ](#) [UPD720114GA-YEU-AT](#) [CYPD2122-20FNXIT](#) [CYPD2122-24LQXIT](#) [LIF-UC120-SWG36ITR50](#) [UPD360-B/6HX](#) [UPD360-A/6HX](#) [CP2102NP1174GM](#) [CY7C65642-28LTXCT](#) [CG8454AM](#) [CYUSB2025-BZXI](#) [FUSB303BTMX](#) [PTN3816EWY](#) [UPD720211K8-711-BAL-A](#) [PTN38003AEWY](#) [PTN38007EWY](#) [CYPM1111-40LQXI](#) [CY7C65216D-32LTXI](#) [USB3317C-GJ-TR](#) [iW657P-65-56BB](#) [CY7C68034-56LTXC](#) [TUSB213IRGYT](#) [TUSB213RGYT](#) [TUSB214RWBT](#) [USB2517I-JZX-TR](#) [USB3318-CP](#) [USB3343-CP](#) [USB3503T-I/ML](#) [CHY100D-TL](#) [STUSB1602AQTR](#) [TUSB214IRWBT](#) [TUSB8043RGCT](#) [USB3319C-CP-TR](#) [USB2532I-1080AEN](#) [CY7C63310-SXC](#) [CY7C64215-28PVXI](#)