



Description

The SE432L is a low voltage three terminal adjustable shunt regulator with a guaranteed thermal stability over applicable temperature ranges. The output voltage can be set to any value between V_{REF} (approximately 1.24 V) to 8V with two external resistors. This device has a typical output impedance of 0.25Ω. Active output circuitry provides a very sharp turn on characteristic, making this device excellent replacement for Zener diodes in many applications.

The SE432L is characterized for operation from -40°C to 105°C, and two package options (SOT-23-3, TO-92) allow the designer the opportunity to select the proper package for their applications.

Features

- Low voltage operation (1.24V)
- Adjustable output voltage $V_0 = V_{REF}$ to 8V
- Wide operating current range 60μA to 100mA
- Low dynamic output impedance 0.30Ω (Typ.)
- Trimmed bandgap design up to ± 0.5%.
- ESD rating is 2.5KV(Per MIL-STD-883D)
- Available in Halogen-Free Packages.

Application

- Linear Regulators
- Adjustable Supplies
- Switching Power Supplies
- Battery Operated Computers
- Instrumentation
- Computer Disk Drives

Pin Configuration

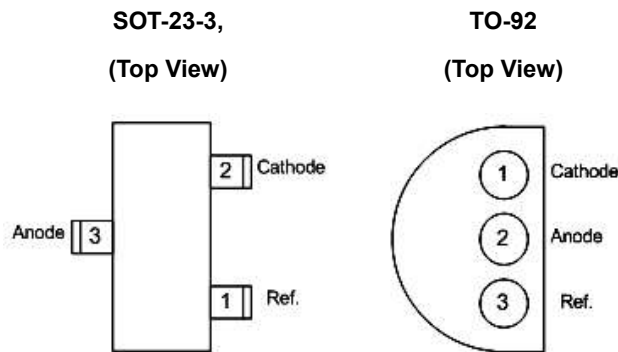

Ordering Information

Part Number	Marking	Production Year Code	Production Week Code	Package	Remarks
SE432XY-HF	<u>S</u> 432Lw	Starting with S, a bar on top of S is for production year 2001, and underlined S is for year 2002.		SOT23-3	X means SOT23-3 ; T means TO92 ; Y means accuracy: 05 : 0.5%; 1 : 1%; 2 : 2% HF : Halogen Free LF : Lead Free
SE432TY-LF	SE432L YYWW-LF	The next character is marked on top for 2003, and underlined for 2004. The naming pattern continues with consecutive characters for later years.	A-Z : 1-26 a-z : 27-52	TO92	



Absolute Maximum Rating

Parameter	Symbol	Maximum	Units
Cathode Voltage	V_{KA}	8	V
Continuous Cathode Current	I_{KA}	150	mA
Reference Current	I_{REF}	10	mA
Operating Junction Temperature Range	T_J	150	°C
Storage Temperature Range	T_{STG}	-45 to 150	°C
Thermal Resistance	θ_{JA}	230 (SOT-23-3)	°C/W
		220 (TO-92)	
Lead Temperature (Soldering) 10 seconds	T_{LEAD}	260	°C

Electrical Characteristics

Parameter		Symbol	Test Conditions & Circuit	Min	Typ	Max	Unit
Reference Voltage	$1.240V \pm 0.5\%$	V_{REF}	Test circuit #1 $V_{KA} = V_{REF}, I_{KA} = 10mA$	1234	1240	1246	mV
	$1.240V \pm 1.0\%$			1228	1240	1252	
	$1.240V \pm 1.5\%$			1221	1240	1259	
	$1.240V \pm 2.0\%$			1215	1240	1265	
Deviation of Reference Voltage over Full Temperature Range		$V_{I(DEV)}$	Test circuit #1 $V_{KA} = V_{REF}, I_{KA} = 10mA,$ $T_A = 0^\circ C - 105^\circ C$	--	68		mV
Ratio of Change in Reference Voltage to the Change in Cathode Voltage		$\Delta V_{REF}/\Delta V_{KA}$	Test circuit #2 $I_{KA} = 10mA, \Delta V_{KA} = 8V \text{ to } V_{REF}$	--	-1.0	-2.7	mV/V
Reference Current		I_{REF}	Test circuit #2 $I_{KA} = 10mA, R1=10k\Omega, R2 = \infty$	--	0.15	-	μA
Deviation of Reference Current over Full Temperature Range		$I_{I(DEV)}$	Test circuit #2 $I_{KA} = 10mA, R1=10k\Omega, R2 = \infty$ $T_A = 0^\circ C - 105^\circ C$	--	0.10		μA
Minimum Cathode Current for Regulation		I_{MIN}	Test circuit #1 $V_{KA} = V_{REF}$	--	60	100	μA
Off-state Cathode Current		I_{OFF}	Test circuit #3 $V_{KA} = 12V, V_{REF} = 0$	--	0.04	0.8	μA
Dynamic Impedance		$ Z_{KA} $	Test circuit #1 $I_{KA} = 100\mu A - 80mA,$ $V_{KA} = V_{REF}, f \leq 1KHZ$	--	0.30	1	Ω

Note 1: Upon Customer Request.



Typical Performance Characteristics

Cathode Current VS Cathode Voltage

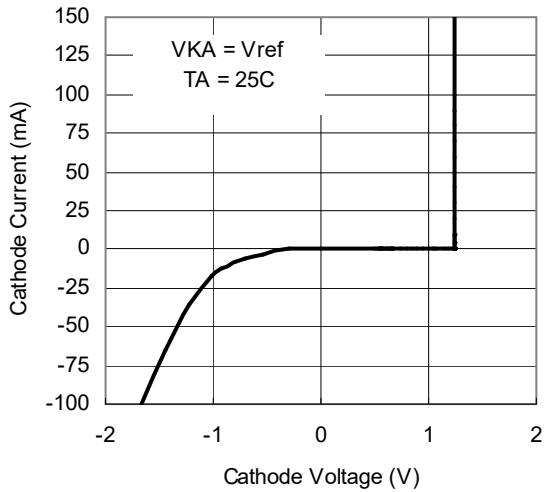

Reference Voltage VS Temperature (Iload=10mA)

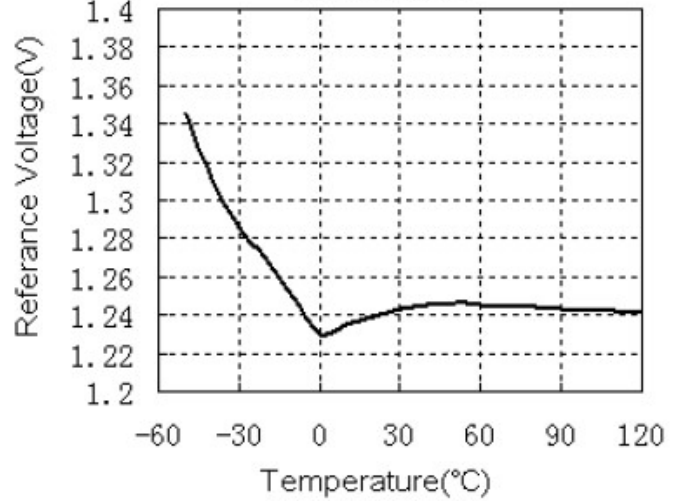

Reference Input Current VS Temperature (R1=10k, R2=∞, Iload=10mA)

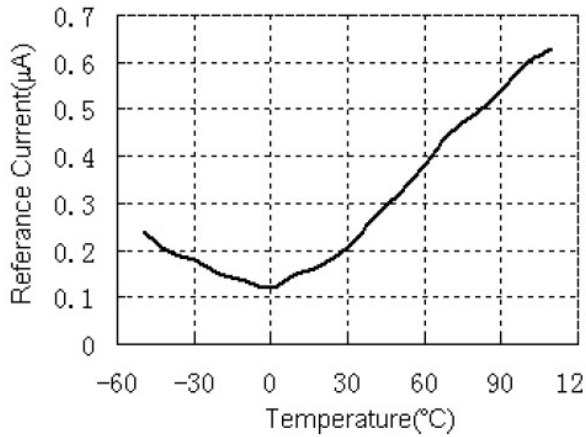

Stability Boundry Conditions

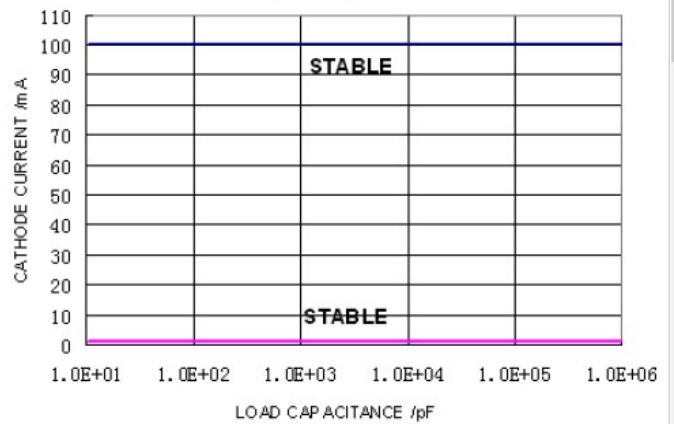



Stability Boundary Condition

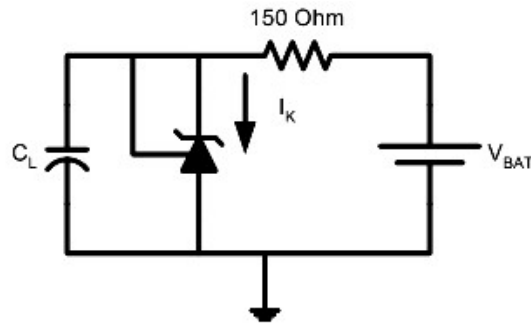
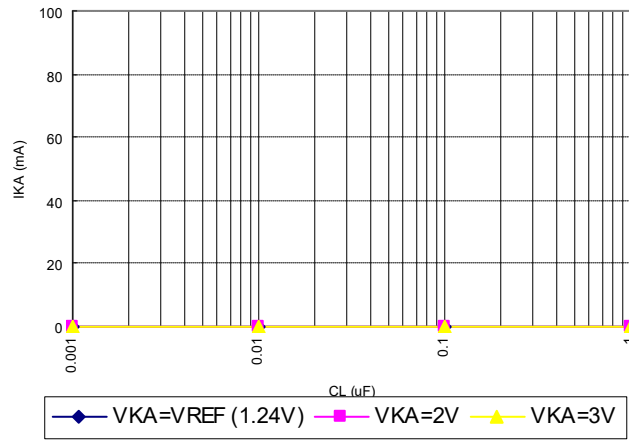

Test Circuit for $V_{KA} = V_{REF}$

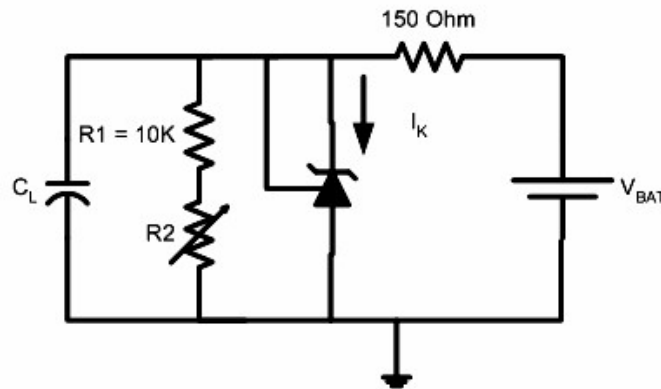

Test Circuit for $V_{KA} = 2\text{V}, 3\text{V}$

The areas under the curves represent conditions that may cause the device to oscillate. For $V_{KA} = 2\text{V}$ and 3V curves, R_2 and V_{BAT} were adjusted to establish the initial V_{KA} and I_K conditions with $C_L = 0$. V_{BAT} and C_L then were adjusted to determine the ranges of stability. As the graph suggested, SE432L is unconditional stable with I_K from 0 to 100mA and with C_L from 0.001uF to 1uF.



Symbol Diagram

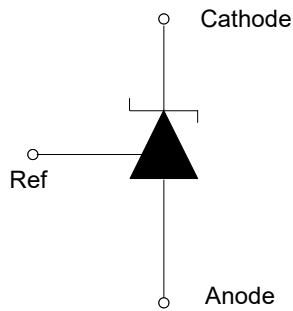

Block Diagram

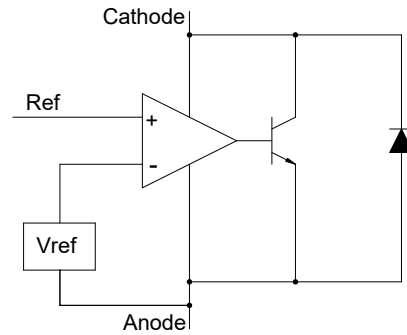

Test Circuits

	$V_{KA} = V_{ref} \left(1 + \frac{R1}{R2}\right) + I_{ref} \times R1$	
<p>Test Circuit 1: $V_{KA} = V_{REF}$</p>	<p>Test Circuit 2: $V_{KA} > V_{REF}$</p>	<p>Test Circuit 3: Off State Current</p>

Application Circuit

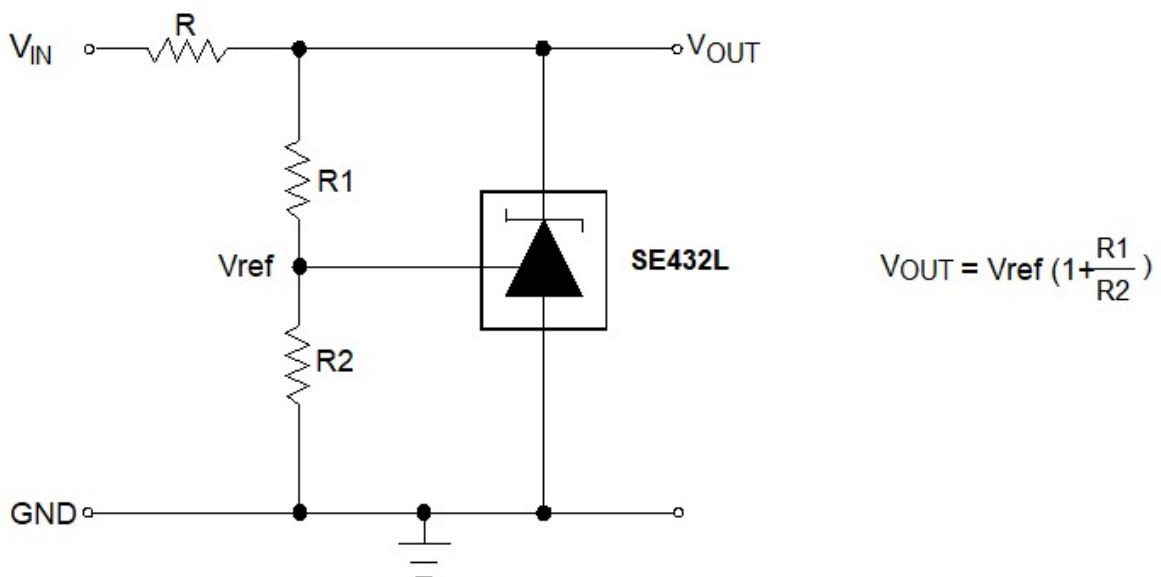



OUTLINE DRAWING SOT-23-3

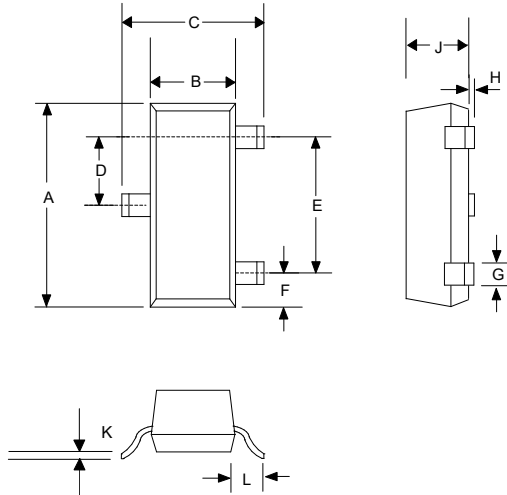

DIMENSIONS				
DIM ^N	INCHES		MM	
	MIN	MAX	MIN	MAX
A	0.110	0.120	2.80	3.04
B	0.047	0.055	1.20	1.40
C	0.083	0.104	2.10	2.64
D	0.035	0.040	0.89	1.03
E	0.070	0.080	1.78	2.05
F	0.018	0.024	0.45	0.60
G	0.015	0.020	0.37	0.51
H	0.0005	0.004	0.013	0.10
J	0.034	0.040	0.887	1.02
K	0.003	0.007	0.085	0.18
L	-	0.027	-	0.69

OUTLINE DRAWING TO-92

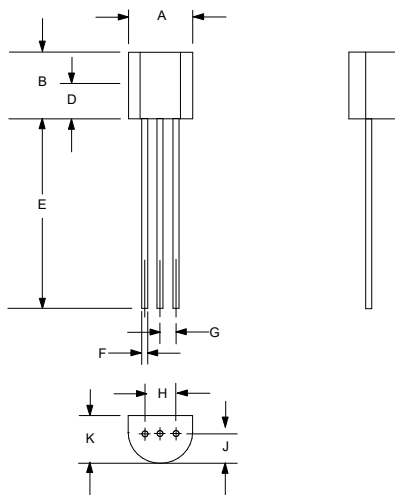

DIMENSIONS				
DIM ^N	INCHES		MM	
	MIN	MAX	MIN	MAX
A	0.175	0.205	4.445	5.207
B	0.170	0.210	4.318	5.334
E	0.500	0.610	12.70	15.50
F	0.016	0.021	0.407	0.533
G	0.045	0.055	1.143	1.397
H	0.095	0.105	2.413	2.667
J	0.080	0.105	2.032	2.667
K	0.125	0.165	3.175	4.191



Customer Support

Seaward Electronics Incorporated – China

Section B, 2nd Floor, ShangDi Scientific Office Complex, #22 XinXi Road

Haidian District, Beijing 100085, China

Tel: 86-10-8289-5700/01/05

Fax: 86-10-8289-5706

Email : sales@seawardinc.com.cn

Seaward Electronics Incorporated – North America

1512 Centre Pointe Dr.

Milpitas, CA95035, USA

Tel: 1-650-444-0713

Last Updated - 11/2/2022

X-ON Electronics

Largest Supplier of Electrical and Electronic Components

Click to view similar products for [Voltage References](#) category:

Click to view products by [Seaward](#) manufacturer:

Other Similar products are found below :

[AS431ARTR-E1](#) [AZ431BR-ATRE1](#) [5962-8686103XC](#) [NCV431BVDMR2G](#) [SCV431AIDMR2G](#) [REF01J/883](#) [SC431ILPRAG](#) [AP432AQG-7](#) [LM4040B25QFTA](#) [TL431BL3T](#) [TL431ACZ](#) [KA431SLMF2TF](#) [KA431SMF2TF](#) [KA431SMFTF](#) [LM4040QCEM3-3.0/NOPB](#) [LM4041C12ILPR](#) [LM4050AIM3X-5.0/NOPB](#) [LM4120AIM5-2.5/NOP](#) [LM431SCCMFX](#) [ZXRE250BSA-7](#) [ZXRE125DN8TA](#) [TS3330AQPR](#) [ZXRE250ASA-7](#) [ZTL431ASE5TA](#) [ADR3512WCRMZ-R7](#) [REF3012AIDBZR](#) [LM385BM-2.5/NOPB](#) [LM385D-2.5R2G](#) [LM4040AIM3-10.0](#) [LM4040CIM3-10.0](#) [LM4040CIM3X-2.0/NOPB](#) [LM4041DH5TA](#) [LM4041QDIM3-ADJ/NO](#) [LM4051BIM3-ADJ/NOPB](#) [LM4051CIM3X-1.2/NOPB](#) [LM4128CMF-1.8/NOPB](#) [LM4132DMF-1.8/NOPB](#) [LM4132EMF-1.8/NOPB](#) [LM4132EMF-2.0/NOPB](#) [LM431CIM](#) [LM385BD-2.5R2G](#) [LM385M-2.5/NOPB](#) [LM4030AMF-4.096/NOPB](#) [LM4040D30ILPR](#) [AP432YG-13](#) [AP431IANTR-G1](#) [AP431AWG-7](#) [AS431ANTR-G1](#) [AS431AZTR-G1](#) [AS431BZTR-E1](#)