

Description

The SE809 is a cost-effective system supervisor Integrated Circuit (IC) designed to monitor V_{CC} in digital and mixed signal systems and provide a warning signal when the system power supply is out of working range, and a reset signal to the host processor when necessary. No external components are required.

The reset output is driven active within 20 μ sec of V_{CC} falling through the reset voltage threshold. Reset is maintained active for a minimum of 150msec after V_{CC} rises above the reset threshold. The SE809 has an active-low $\overline{\text{RESET}}$ output. The output of the SE809 is guaranteed valid down to $V_{CC}=1V$.

The SE809 is optimized to reject fast transient glitches on the V_{CC} line. Low supply current of 18 μ A ($V_{CC}=3.3V$) makes these devices suitable for battery powered applications. The output voltages range from 1.7V to 4.5V in 100mV increments. Standard voltage versions are 2.63, 2.93, 3.08, 4.0, 4.38, and 4.63V.

Pin Configuration

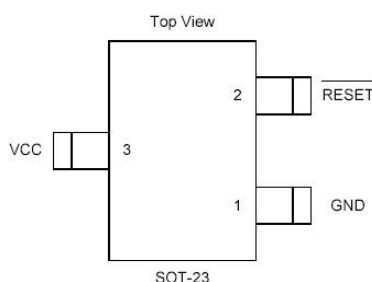

Features

- Precision V_{CC} Monitor for 2.8V, 3.0V, 3.3V, and 5.0V Supplies
- 150msec Guaranteed Minimum $\overline{\text{RESET}}$ Output Duration
- $\overline{\text{RESET}}$ Output Guaranteed to $V_{CC}=1.0V$
- Low 7 μ A Supply Current
- V_{CC} Transient Immunity
- No External Components
- Small SOT-23 Package and TO-92 Package
- Wide Operating Temperature: 0°C to 85°C

Application

- Computers
- Embedded systems
- Battery powered equipment
- Critical μ P power supply monitoring

Application Diagram

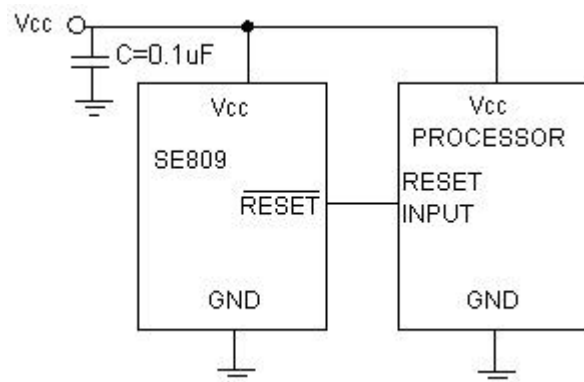



Ordering/Marking Information

Ordering Information	Marking Information	
SE809-LF-XXV	S809 \bar{x} a \cdot	<p>Starting with 8, a bar on top of 8 is for production year 2003, and underlined 8 is for year 2004. The next character is marked on top for 2005, and underlined for 2006. The naming pattern continues with consecutive characters for later years. The "x" denotes a suffix for V_{CC} threshold. The last character is the week code. (A-Z: 1-26, a-z: 27-52)</p> <p>A dot on top right corner is for lead-free process. No dot on top right corner is for Halogen Free process</p>
SE809-HF-XXV	S809 \bar{x} a	
Suffix	Reset V _{CC} threshold(V)	
L	4.63	
M	4.38	
J	4.00	
T	3.08	
S	2.93	
R	2.63	
Z	2.30	

Absolute Maximum Ratings⁽¹⁾

Parameter	Symbol	Value	Units
Input Voltage	V _{CC}	5.5	V
Output Voltage	RESET	-0.3 to (V _{CC} + 0.3)	V
Input Current		20	mA
Output Current	I _{OUT}	20	mA
Power Dissipation	P _D	Internally Limited ⁽³⁾	
Output Short Circuit Duration		Infinite	
Thermal Resistance, Junction-to-Ambient	Θ _{JA}	230	°C/W
Operating Temperature Range	T _A	0 ~ 85	°C
Lead Temperature (Soldering, 10 sec.)		260	°C
Junction Temperature	T _J	0 to +125	°C
Storage Temperature	T _S	-60 to +150	°C

Operating Rating⁽²⁾

Parameter	Symbol	Value	Units
Supply Input Voltage	V _{CC}	+2.0V to +5.5	V
Junction Temperature	T _J	0 to +125	°C

Electrical Characteristics

$V_{CC}=5V$ for L/M/J ; $3.3V$ for T/S ; $3.0V$ for R , $T_A = 25^{\circ}C$, unless otherwise specified.

Symbol	Parameter	Condition	Min	Typ	Max	Unit
V_{CC}	Input Voltage		2.0		5.5	V
I_{CC}	Supply Current		--	7	-	μA
V_{TH}	Reset Threshold	SE809L-4.63V	4.514	4.63	4.746	V
		SE809M-4.38V	4.271	4.38	4.49	
		SE809J-4.00V	3.90	4.00	4.1	
		SE809T-3.08V	3.003	3.08	3.157	
		SE809S-2.93V	2.857	2.93	3.003	
		SE809R-2.63V	2.564	2.63	2.696	
		SE809Z-2.30V	2.194	2.25	2.306	
	Reset Threshold Temperature Coefficient ⁽⁴⁾		--	30	--	ppm/ $^{\circ}C$
	V_{CC} to Reset Delay $V_{CC} = V_{TH}$ to ($V_{TH} - 100mV$)		--	20	--	μsec
	Reset Active Timeout Period		--	150		msec
V_{OL}	RESET Output Voltage Low	$I_{SINK} = 3.2mA$	--	--	0.4	V
V_{OH}	RESET Output Voltage High	$I_{SOURCE} = 800\mu A$	$0.8V_{CC}$	--	--	V

PIN DESCRIPTION:

Pin No.	Symbol	Description
1	GND	Ground
2	RESET	RESET output remains low while V_{CC} is below the reset voltage threshold and for 150msec(typ) after V_{CC} rises above reset threshold
3	V_{CC}	Supply Voltage (typ.)

Note 1: Exceeding the absolute maximum rating may damage the device.

Note 2: The device is not guaranteed to function outside its operating rating.

Note 3: The maximum allowable power dissipation at any T_A (ambient temperature) is calculated using: $P_{D(MAX)} = (T_{J(MAX)} - T_A)/\theta_{JA}$. Exceeding the maximum allowable power dissipation will result in excessive die temperature, and the regulator will go into thermal shutdown. See "Thermal Consideration" section for details

Note 4: RESET threshold temperature coefficient is the worst case voltage change divided by the total temperature range.



Typical Performance Characteristics

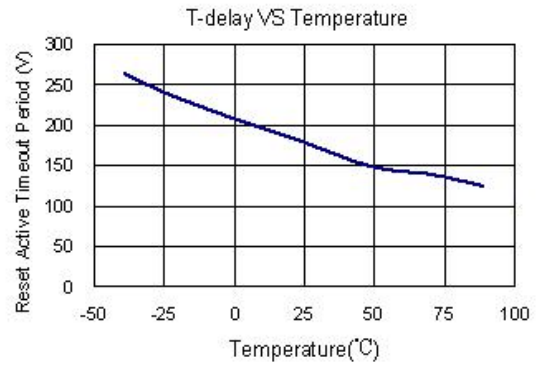
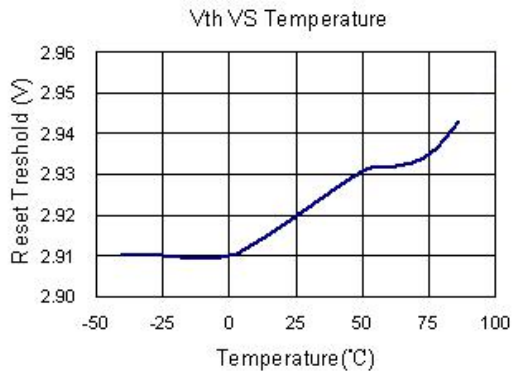



OUTLINE DRAWING SOT-23

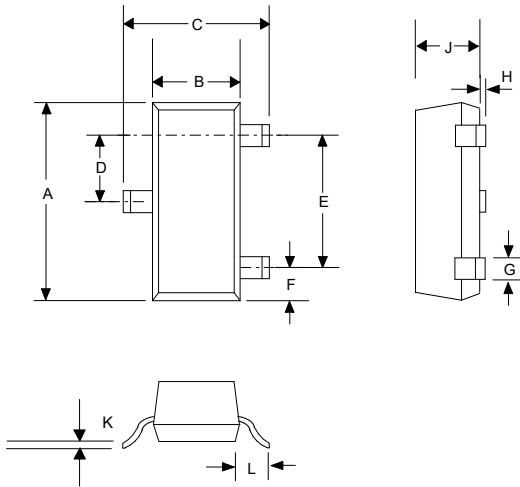

DIMENSIONS				
DIM ^N	INCHES		MM	
	MIN	MAX	MIN	MAX
A	0.110	0.120	2.80	3.04
B	0.047	0.055	1.20	1.40
C	0.083	0.104	2.10	2.64
D	0.035	0.040	0.89	1.03
E	0.070	0.080	1.78	2.05
F	0.018	0.024	0.45	0.60
G	0.015	0.020	0.37	0.51
H	0.0005	0.004	0.013	0.10
J	0.034	0.040	0.887	1.02
K	0.003	0.007	0.085	0.18
L	-	0.027	-	0.69

OUTLINE DRAWING TO-92

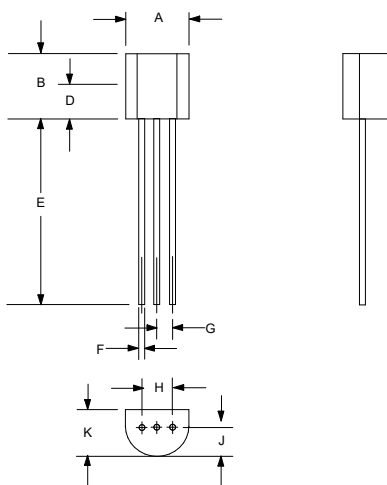

DIMENSIONS				
DIM ^N	INCHES		MM	
	MIN	MAX	MIN	MAX
A	0.175	0.205	4.445	5.207
B	0.170	0.210	4.318	5.334
E	0.500	0.610	12.70	15.50
F	0.016	0.021	0.407	0.533
G	0.045	0.055	1.143	1.397
H	0.095	0.105	2.413	2.667
J	0.080	0.105	2.032	2.667
K	0.125	0.165	3.175	4.191



Contact Information

Seaward Electronics Incorporated – China

Rm 1605, Building 1, International Pioneering Park, #1 Shangdi Xinxu Rd

Haidian District, Beijing 100085, China

Tel: 86-10-8289-5700/01/05

Fax: 86-10-8289-5706

Email: sales@seawardinc.com.cn

Seaward Electronics Corporation – Taiwan

2F, #181, Sec. 3, Minguan East Rd,

Taipei, Taiwan R.O.C

Tel: 886-2-2712-0307

Fax: 886-2-2712-0191

Email: sales@seawardinc.com.tw

Seaward Electronics Incorporated – North America

1512 Centre Pointe Dr.

Milpitas, CA95035, USA

Tel: 1-408-821-6600

Last Updated - 6/13/2018

X-ON Electronics

Largest Supplier of Electrical and Electronic Components

Click to view similar products for [Supervisory Circuits](#) category:

Click to view products by [Seaward](#) manufacturer:

Other Similar products are found below :

[CAT853STBI-T3](#) [RT9818C-27GU3](#) [DS1232L](#) [NCV302HSN45T1G](#) [STM6710FWB7F](#) [PT7M6127NLTA3EX](#) [XC6118C25AGR-G](#)
[ISL88011IH526Z-TK](#) [ISL88013IH529Z-TK](#) [ISL88705IP846Z](#) [ISL88706IP831Z](#) [ISL88708IB844Z](#) [ISL88708IP831Z](#) [TCM811MERCTR](#)
[X40420S14-A](#) [X40421S14-C](#) [X40430S14-A](#) [X40430S14I-A](#) [X40430S14I-B](#) [X40431S14-A](#) [X40431S14-B](#) [X40431S14-C](#) [X40431S14I-A](#)
[X40431S14I-B](#) [X40431S14I-C](#) [X4043P-2.7](#) [X4043PI-2.7](#) [X4043S8-2.7T1](#) [X4043S8IZ-2.7](#) [X4043S8IZT1](#) [X4043S8T1](#) [X4045P](#) [X4045PI](#)
[X4045PI-2.7](#) [X4045S8-2.7T1](#) [X4045S8IZ](#) [X4045S8T1](#) [X4163P](#) [X4163P-2.7](#) [X4163PI](#) [X4163PI-2.7](#) [X4163S8](#) [X4165P](#) [X4165P-2.7](#)
[X4165PI](#) [X4165PI-2.7](#) [X4165S8I-2.7](#) [X4283S8I](#) [X4323S8-2.7](#) [X4323S8I-2.7](#)