



General Description (产品描述)

The SE82XX series is a high voltage , ultralow-power regulator. The device can allow an input voltage as high as 30V. The typical quiescent current is only 2 μ A. The device is available in fixed output voltages of 3V/ 3.3V and 5.0V.

The device features integrated short-circuit and thermal shutdown protection.

Although designed primarily as fixed voltage regulators, the device can be used with external components to obtain variable voltages.

Features(产品特性)

- Low Quiescent Current: 2 μ A
- High Input Voltage: Up to 30V
- High Output Current: 100mA
- Dropout Voltage: 500mV@100mA
- Fixed Output Voltages: 3V/ 3.3V and 5.0V
- High-accuracy Output Voltage
- Integrated Short-Circuit Protection
- Integrated Thermal Protection
- Available Packages: SOT23-3, SOT89

Applications(产品应用)

- Battery-powered equipment
- Smoke detector and sensor
- Microcontroller Applications
- Smart electric meter



Typical Application (典型应用电路)

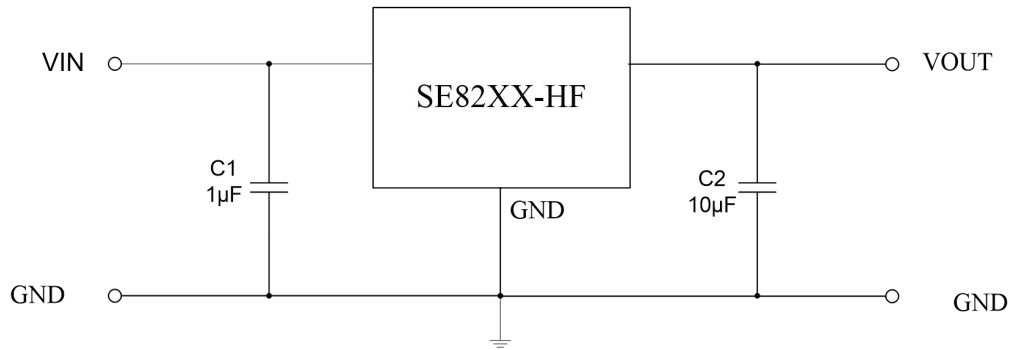

Pin Configuration (管脚排列)

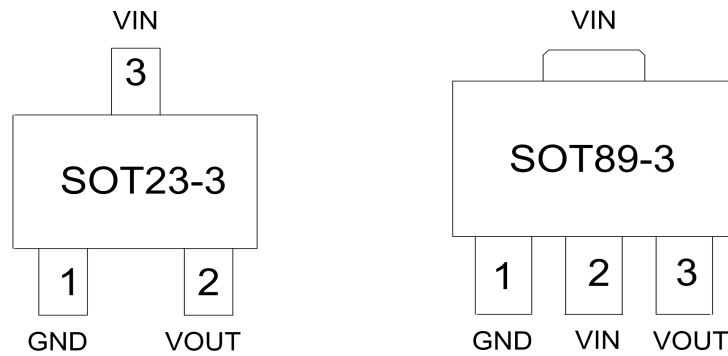

Pin Description (管脚功能描述)

Pin Name	Pin Function Description
VIN	In put pin
VOUT	Out put pin
GND	Ground pin



Functional Block Diagram (功能框图)

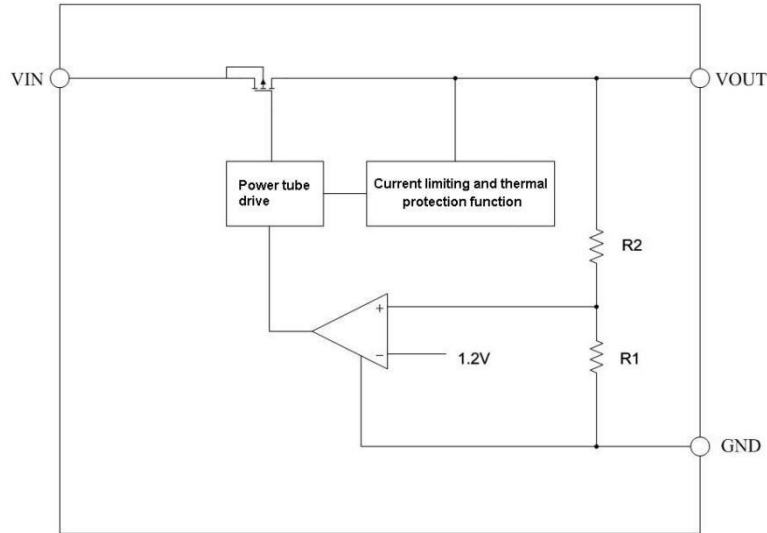

Ordering Information (订货信息)

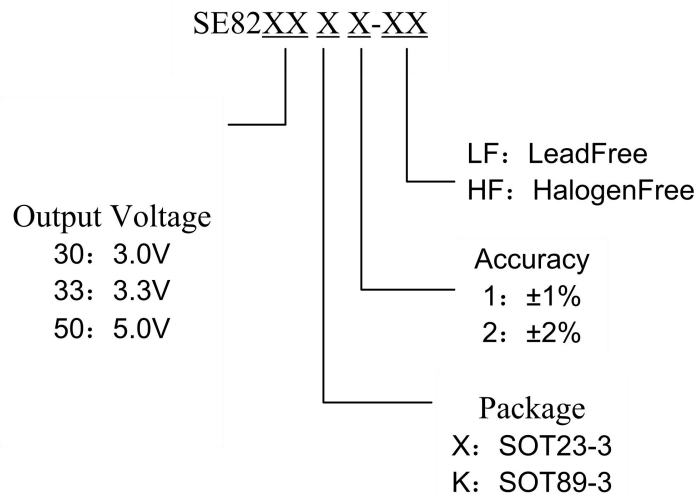



Absolute Maximum Ratings(最大额定参数)

Symbol	Parameter	Value	Units
V_{IN}	Input Supply Voltage	30	V
$V_{OUT}---GND$	Output Voltage TO GND	15	
T_A	Operating Temperature	-40----105	°C
T_{STG}	Storage Temperature	-40---150	
T_J	Maximum Junction Temperature	150	
T_{LEAD}	Lead Temperature (Soldering) 10 seconds	260	
θ_{JA}	Thermal Resistance, Junction-to-Ambient	165(SOT89)	°C/W
		280(SOT23-3)	
P_D	Power Consumption	750(SOT89)	mW
		446(SOT23-3)	

Note :Stresses exceeding the range specified under “Absolute Maximum Ratings” may cause substantial damage to the device. Functional operation of this device at other conditions beyond those listed in the specification is not implied and prolonged exposure to extreme conditions may affect device reliability.

Recommended Operating Conditions(推荐工作条件)

Symbol	Parameter	Maximum	Units
V_{IN}	Input Supply Voltage	24	V
T_A	Operating Temperature	-20----85	°C
T_{LEAD}	Lead Temperature (Soldering) 10 seconds	230	°C



Electrical Characteristics(电气参数)

(TA=25° C, CIN=1uF, VIN=VOUT+2.0V, COUT=10uF, unless otherwise noted)

Symbol	Parameter	Conditions	Min	Typ	Max	Unit
V _{IN}	Input Supply Voltage		2.8		24	V
V _{OUT}	Output Voltage Accuracy	I _{OUT} =10mA	-1%		1%	V
			-2%		2%	V
I _Q	Quiescent Current	V _{IN} =12V, NO Load		2	3	μA
I _{OUT}	Output Current				150	mA
V _{DROP}	Dropout Voltage	I _{OUT} =10mA ΔV _{OUT} = - V _{OUT} *2%		50		mV
		I _{OUT} =100mA ΔV _{OUT} = - V _{OUT} *2%		500		mV
V _{LR}	Load Regulation	1mA ≤ I _{OUT} ≤ 150mA		40		mV
V _{SR}	Line Regulation	I _{OUT} =1mA, V _{IN} =(V _{OUT} +2V) to 24V		0.2		%/V
I _{short}	Short Current			100		mA
T _{SHDN}	Thermal Protection			125		°C



Outline Drawing for SOT-23-3

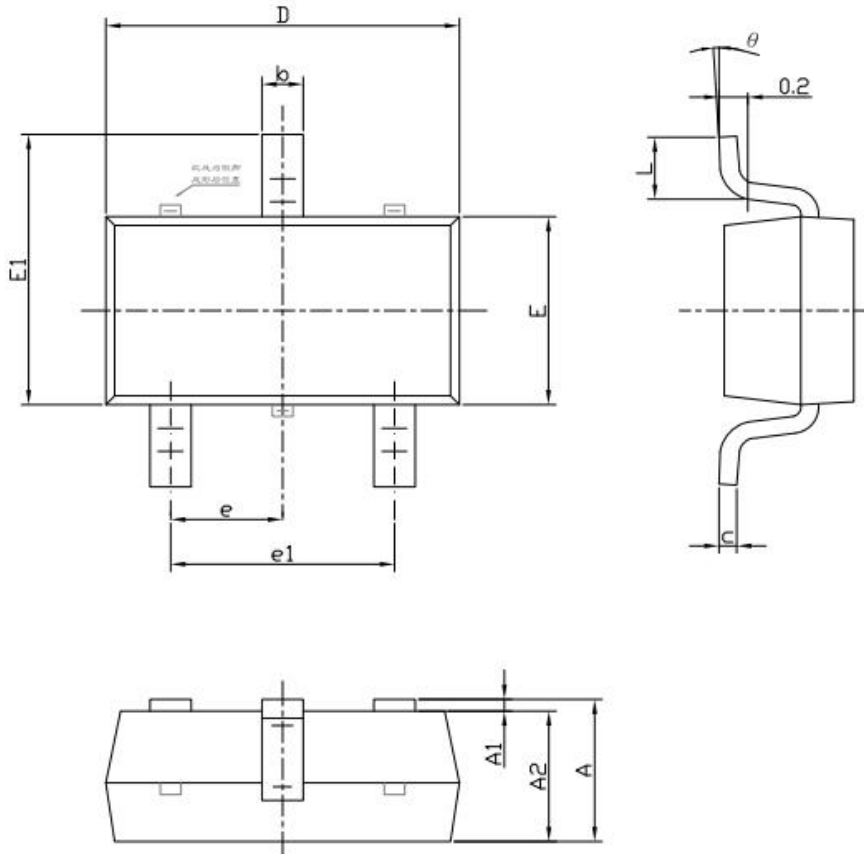

Symbol	Dimensions In Millimeters		Dimensions In Inches	
	Min	Max	Min	Max
A	1.050	1.250	0.041	0.049
A1	0.000	0.100	0.000	0.004
A2	1.050	1.150	0.041	0.045
b	0.300	0.500	0.012	0.020
c	0.100	0.200	0.004	0.008
D	2.820	3.020	0.111	0.119
E	1.500	1.700	0.059	0.067
E1	2.650	2.950	0.104	0.116
e	0.950(BSC)		0.037(BSC)	
e1	1.800	2.000	0.071	0.079
L	0.300	0.600	0.012	0.024
θ	0°	8°	0°	8°



Outline Drawing for SOT-89

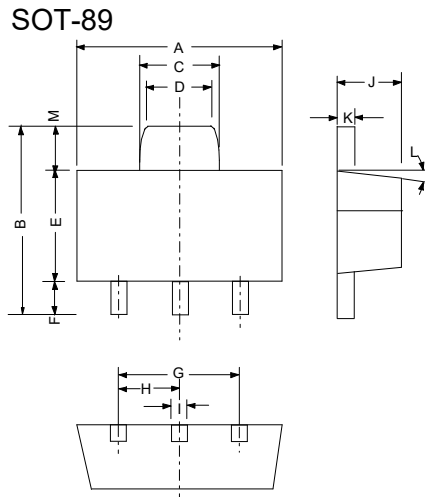

DIM ^N	DIMENSIONS			
	INCHES		MM	
	MIN	MAX	MIN	MAX
A	0.173	0.181	4.400	4.600
B	0.159	0.167	4.050	4.250
C	0.067	0.075	1.700	1.900
D	0.051	0.059	1.300	1.500
E	0.094	0.102	2.400	2.600
F	0.035	0.047	0.890	1.200
G	0.118REF		3.00REF	
H	0.059REF		1.50REF	
I	0.016	0.020	0.400	0.520
J	0.055	0.063	1.400	1.600
K	0.014	0.016	0.350	0.410
L	10°TYP		10°TYP	
M	0.028REF		0.70REF	

联系方式:

北京思旺电子技术有限公司-中国总部

地址: 中国北京市海淀区信息路 22 号上地科技综合楼 B 座二层

邮编: 100085

电话:010-82895700/1/5

传真:010-82895706

Seaward Electronics Corporation – 台湾办事处

2F, #181, Sec. 3, Minguan East Rd,

Taipei, Taiwan R.O.C

电话: 886-2-2712-0307

传真: 886-2-2712-0191

Seaward Electronics Incorporated – 北美办事处

1512 Centre Pointe Dr.

Milpitas, CA95035, USA

电话: 1-408-821-6600

X-ON Electronics

Largest Supplier of Electrical and Electronic Components

Click to view similar products for [LDO Voltage Regulators](#) category:

Click to view products by [Seaward](#) manufacturer:

Other Similar products are found below :

[M38D29FFHP#U1](#) [702103A](#) [717726C](#) [742457H](#) [MP20051DN-LF-Z](#) [R5F111PGGFB#30](#) [AP7363-SP-13](#) [NCP103AMX285TCG](#)
[NCV8664CST33T3G](#) [NCV8752AMX28TCG](#) [L9454](#) [AP7362-HA-7](#) [LX13043CLD](#) [TCR3DF185,LM\(CT](#) [TCR3DF24,LM\(CT](#)
[TCR3DF285,LM\(CT](#) [TCR3DF31,LM\(CT](#) [TCR3DF45,LM\(CT](#) [TLF4949EJ](#) [L9708](#) [L970813TR](#) [030014BB](#) [059985X](#) [EAN61387601](#)
[EAN61573601](#) [NCP121AMX173TCG](#) [NCP4687DH15T1G](#) [NCV8703MX30TCG](#) [701326R](#) [702087BB](#) [755078E](#) [TCR2EN28,LF\(S](#)
[LM1117DT-1.8/NO](#) [LT1086CM#TRPBF](#) [AZ1085S2-1.5TRE1](#) [MAX15101EWL+T](#) [NCV8170AXV250T2G](#) [SCD337BTG](#)
[TCR3DF27,LM\(CT](#) [TCR3DF19,LM\(CT](#) [TCR3DF125,LM\(CT](#) [TCR2EN18,LF\(S](#) [MAX15103EWL+T](#) [TS2937CZ-5.0 C0](#) [MAX8878EUK30-](#)
[T](#) [MAX663CPA](#) [NCV4269CPD50R2G](#) [NCV8716MT30TBG](#) [AZ1117IH-1.2TRG1](#) [MP2013GQ-P](#)