

GENERAL DESCRIPTION

SE87XX series is designed for power-sensitive applications. It includes a precision and high voltage input stage, an ultra-low-power bias current branch, and results in a ultra-low-power and low-dropout linear regulator.

The SE87XX operates from an input voltage of $V_{OUT}+1V$ to 40V, consumes only 2.6 μ A of quiescent current, and offers 1% initial accuracy and SoftStart function. At power startup, the output voltage overshoot is less than 100mV.

The SE87XX regulators is available in standard SOT89-3L, and SOT23-3L packages. Standard products are Pb-free and Halogen-free.

FEATURES

- Input voltage: 4.5V~40V
- Output voltage: 1.8V~5.7V
- Output accuracy: $<\pm 1\%$
- Output current: 100mA (Typ.)
- PSRR: 60dB @ 100Hz
- Quiescent current: 4.2 μ A @ $V_{IN} = 12V$ (Typ.)
- ESD HBM: 3KV
- Recommend capacitor: 10 μ F
- No overshoot from short circuit recovery
- UVLO at 1.8V

APPLICATIONS

- Battery-powered Smoke sensor
- Smoke sensor
- Microcontrollers
- Household appliances and instruments

TYPICAL APPLICATION CIRCUIT

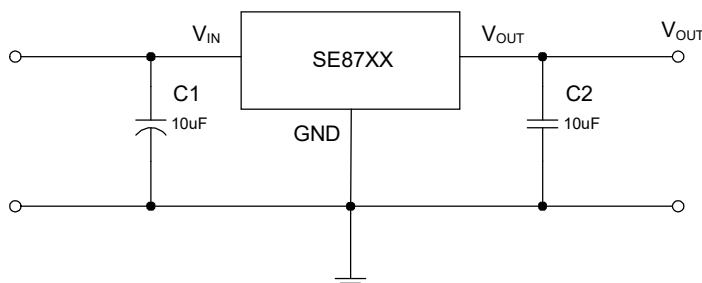

In plugging in application, C_{IN} is recommended to use 10 μ F electrolytic capacitor or 10 μ F MLCC with 2 ohm serial resistors to prevent large input voltage spike when plugging in. See APPLICATION INFORMATION for more information.

PIN CONFIGURATION

(Customer pin assignments are available)

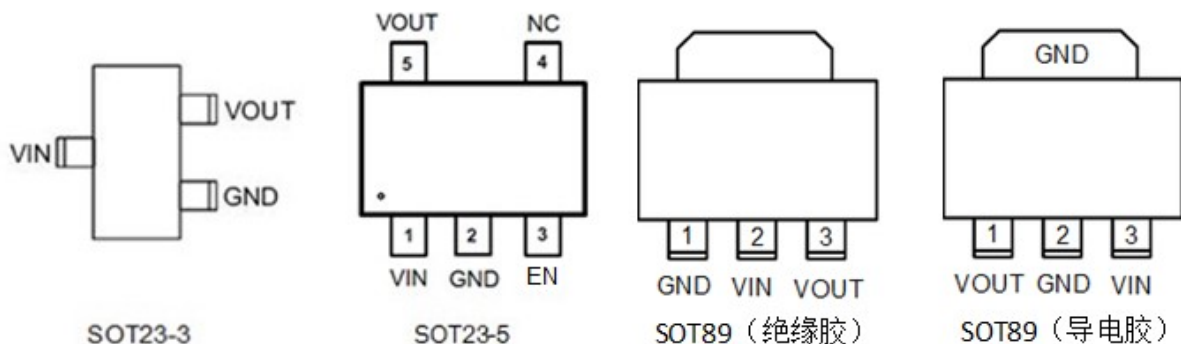

PIN DESCRIPTION

SYMBOL	I/O	DESCRIPTION
GND	Ground	Ground
VIN	Power	Input
VOUT	O	Output

ORDERING INFORMATION

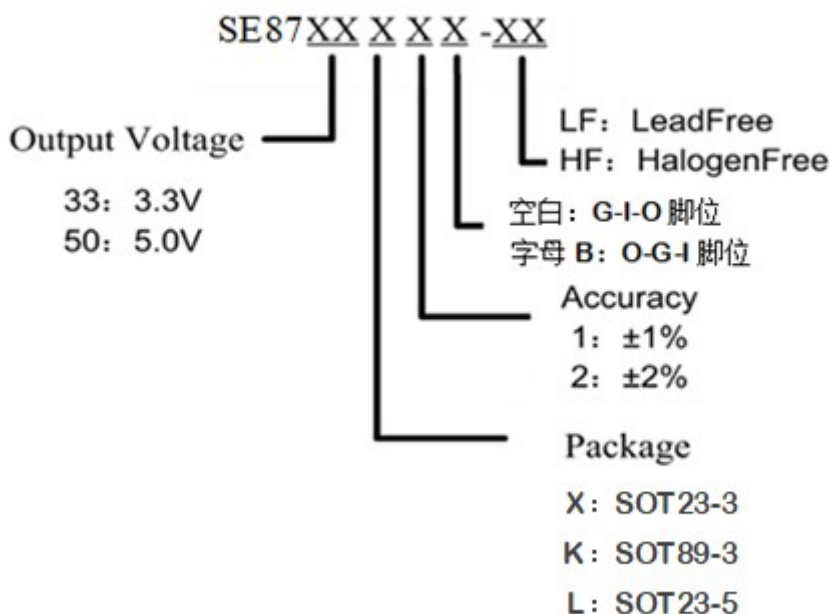

ABSOLUTE MAXIMUM RATINGS (Note)

SYMBOL	ITEMS	VALUE	UNIT
V_{IN}	Input Voltage	-0.3~45	V
V_{OUT}	Output Voltage	-0.3~6.5	V
P_{DMAX}	Power Dissipation	OTP limited	W
T_J	Junction Temperature	-40~150	°C
T_{stg}	Storage Temperature	-55 to 150	°C
T_{solder}	Package Lead Soldering Temperature (10s)	260	°C
ESD MM	Machine Mode	200	V
ESD HBM	Human Body Mode	3000	V
θ_{JA}	Thermal Resistance, Junction-to-Ambient	165 (SOT89)	°C/W
		280 (SOT23)	
P_D	Power Consumption	750 (SOT89)	mW
		250 (SOT23)	

Note: Exceed these limits to damage to the device. Exposure to absolute maximum rating conditions may affect device reliability.

RECOMMENDED OPERATING RANGE

SYMBOL	ITEMS	VALUE	UNIT
V_{IN}	V_{IN} Supply Voltage	4.5 to 40	V
$R_{\theta JA}$	Thermal Resistance on PCB	45	°C/W
T_{OPT}	Operating Temperature	-40 to +105	°C

SIMPLIFIED BLOCK DIAGRAM

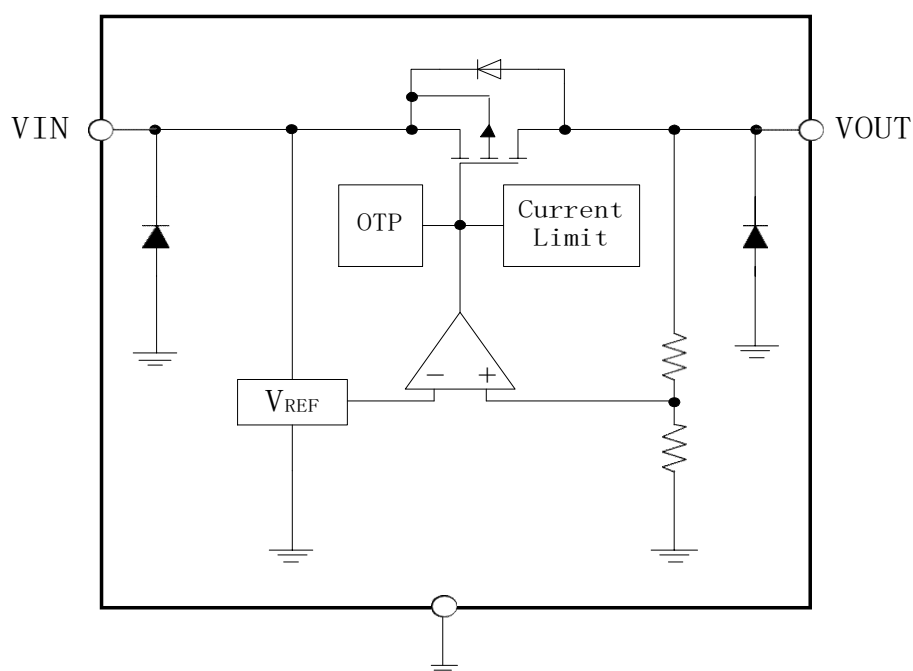

ELECTRICAL CHARACTERISTICS

($V_{IN}=12V$; $T_j=25^{\circ}C$ unless otherwise noted.)

Symbol	Parameter	Conditions	Min	Typ	Max	Unit
V_{IN}	Input Supply Voltage		4.5		40	V
V_{OUT}	Output Voltage Accuracy	$I_{OUT}=10mA$	-1%		1%	V
			-2%		2%	V
I_Q	Quiescent Current			4.5	8	μA
I_{OUT}	Output Current		150	200		mA
V_{DROP}	Dropout Voltage	$I_{OUT}=10mA$ $\Delta V_{OUT} = -V_{OUT} * 2\%$		60		mV
		$I_{OUT}=100mA$ $\Delta V_{OUT} = -V_{OUT} * 2\%$		600		mV
V_{LR}	Load Regulation	$1mA \leq I_{OUT} \leq 100mA$		20		mV
V_{SR}	Line Regulation	$I_{OUT}=1mA$, $V_{IN}=(V_{OUT}+4V)$ to 45V		0.08		%/V
PSRR	Power Supply Rejection Ratio ($V_{in}=10V$, $V_{pp}=0.5V$, $I_{out}=1mA$)	Freq=100Hz		60		dB
		Freq=1KHz		50		dB
		Freq=10KHz		40		dB
I_{LIMIT}	Current Limit	$V_{IN}=(V_{OUT}+1V)$ to 30V $R_{LOAD}=V_{OUT}/1A$		350		mA
T_{SHDN}	Thermal Protection			165		$^{\circ}C$
TC_{VOUT}	Output Voltage Temperature Coefficient	$I_{OUT}=10mA$ $-40^{\circ}C \leq T_{AMB} \leq 100^{\circ}C$		± 100		ppm/ $^{\circ}C$

TYPICAL PERFORMANCE CHARACTERISTICS

$C_{IN} = 10\mu F$, $C_{OUT} = 10\mu F$, $T_{OPT} = 25^{\circ}C$, unless specified otherwise. (SE87XXK2B Package)

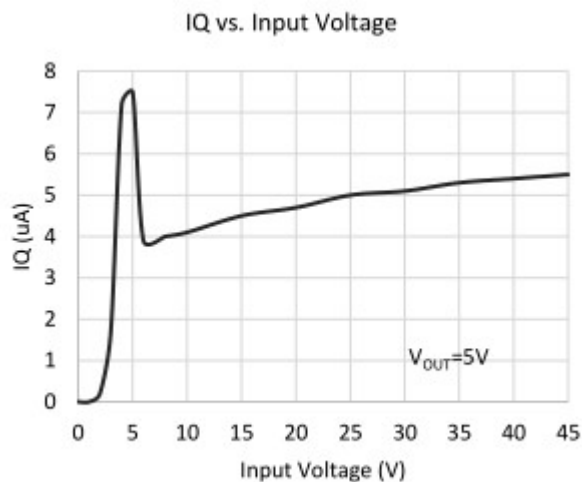
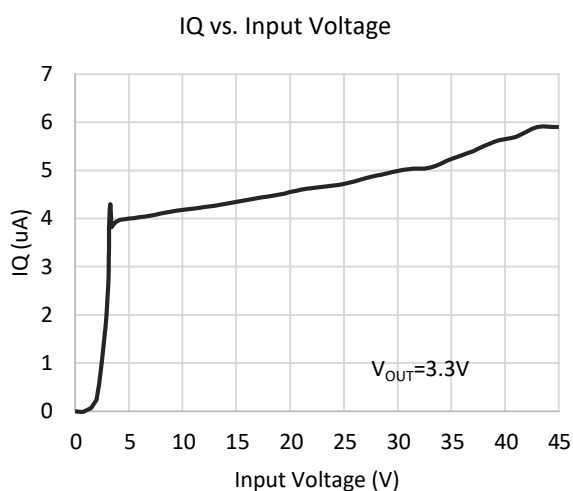

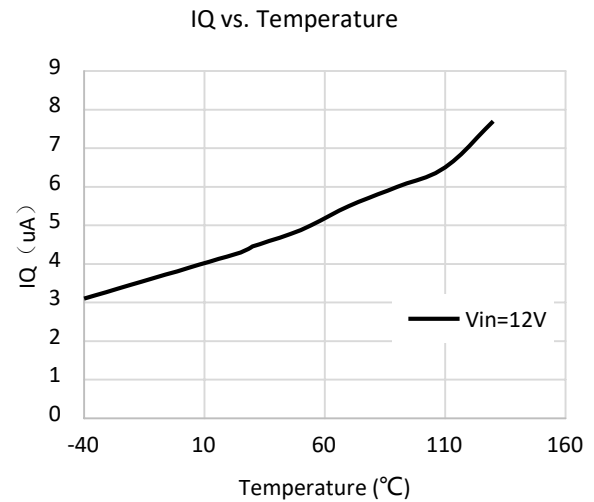
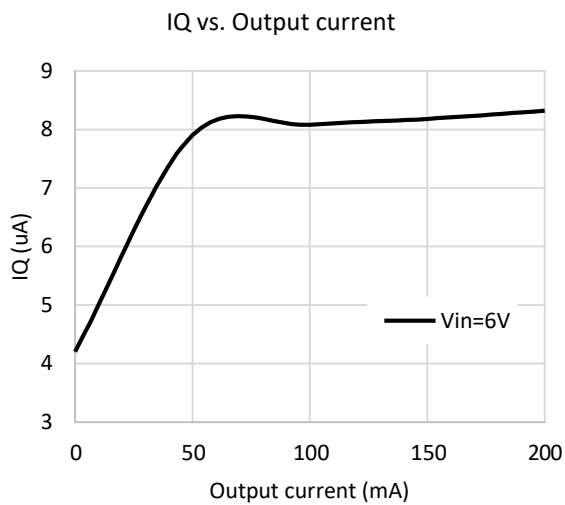
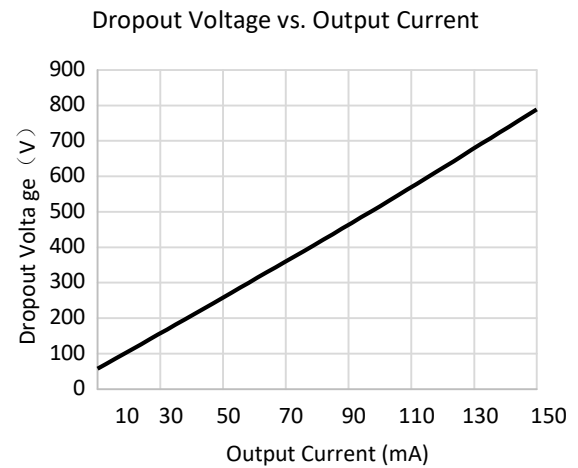
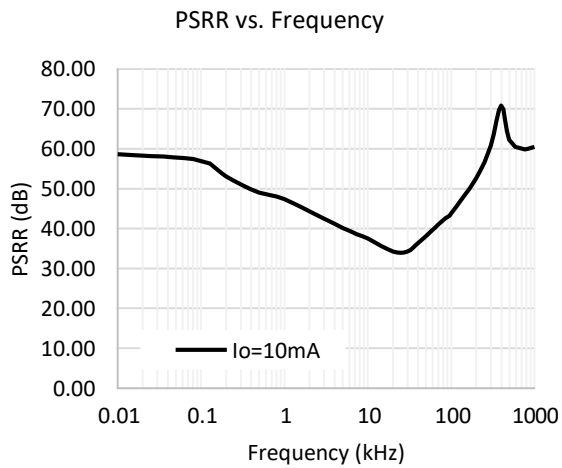
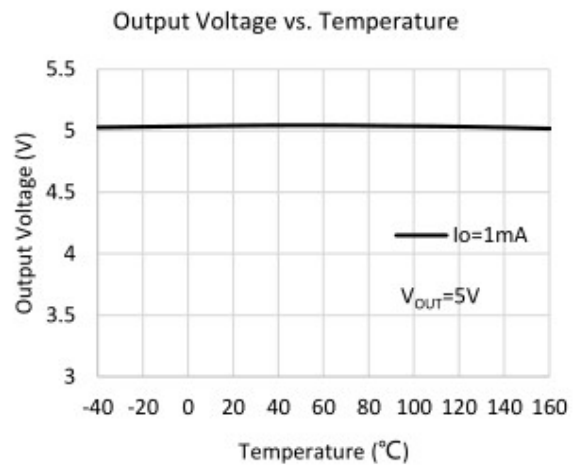
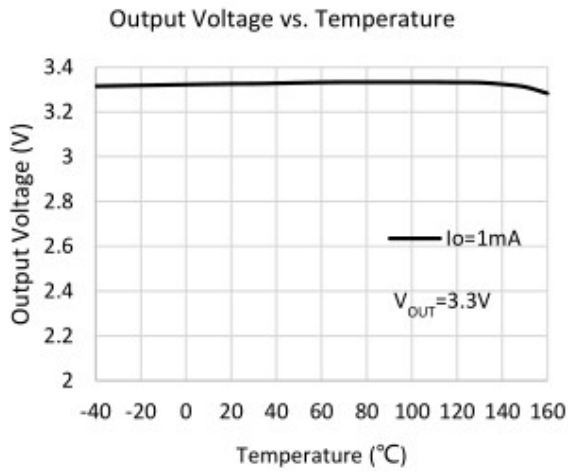

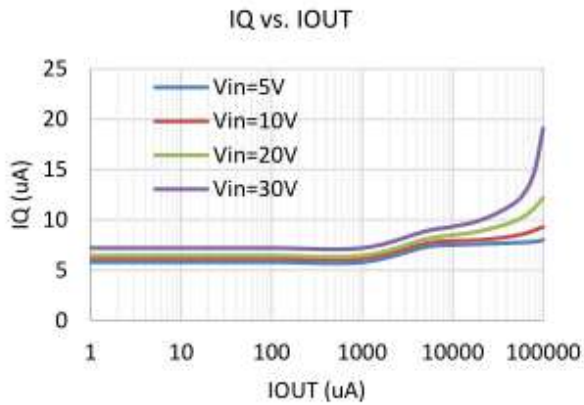

Power ON/OFF

CH1 : V_{IN}

CH2 : V_{OUT}

$V_{IN}=40V$

$I_{OUT}=1mA$

$V_{OUT}=5V$

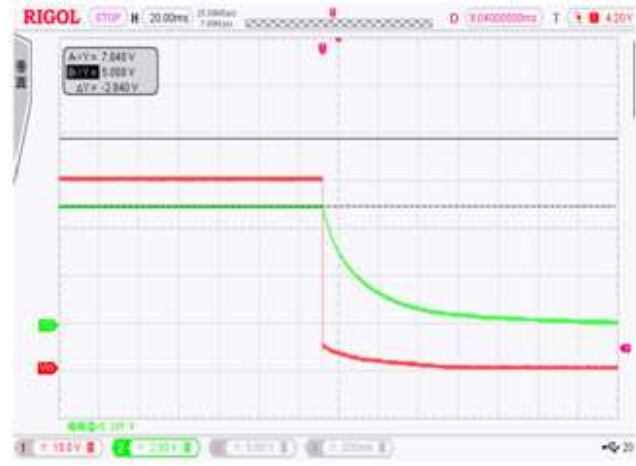

Line Transient

CH1: V_{IN}

CH2 : V_{OUT}

$V_{IN}=6V-12V$

$I_{OUT}=1mA$

$V_{OUT}=5V$



$V_{IN}=6V-12V$

$I_{OUT}=10mA$

$V_{OUT}=5V$



APPLICATION INFORMATION

INPUT CAPACITOR

An input capacitor of $10\mu\text{F}$ is required between the VIN and GND pin. The capacitor shall be placed as close as possible to VIN pin, and the use of electrolytic capacitors is recommended.

OUTPUT CAPACITOR

The recommended is $10\mu\text{F}$ MLCC capacitor. The minimum capacitance for stable and correct operation is $1\mu\text{F}$.

NO-LOAD STABILITY

The SE87XX will remain stable and in regulation with no external load. This is especially important in CMOS RAM keep-alive applications.

TYPICAL CIRCUIT

The following figure shows a typical application circuit for the SE87XX devices. Please keep in mind that in-rush current can push up the Vin overshoot by as much as 50%. For example, when $V_{in}=30\text{V}$, the in-rush caused spike voltage can be as high as 45V. Therefore the voltage rating of C_{in} needs to be higher than 50% of the application.

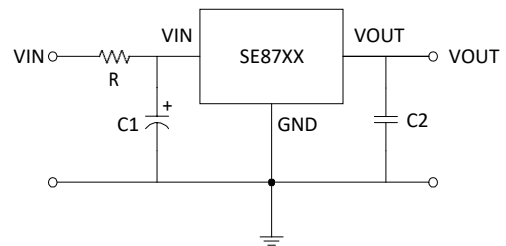

In live insertion application, it is suggested that R, C1 are selected as following:

1. $C1=10\mu\text{F} \sim 100\mu\text{F}$ electrolytic capacitor with maximum voltage greater than 50V, $R=0$
2. If the average current is known, for example at 10mA, then for an input voltage of 20V, the $C1=1\mu\text{F} \sim 10\mu\text{F}$ ceramic or electrolytic with maximum voltage greater than 40V and $R=1\text{K}\Omega$ in the type of 1206 at 1/4W rating can be selected.

PACKAGE OUTLINE

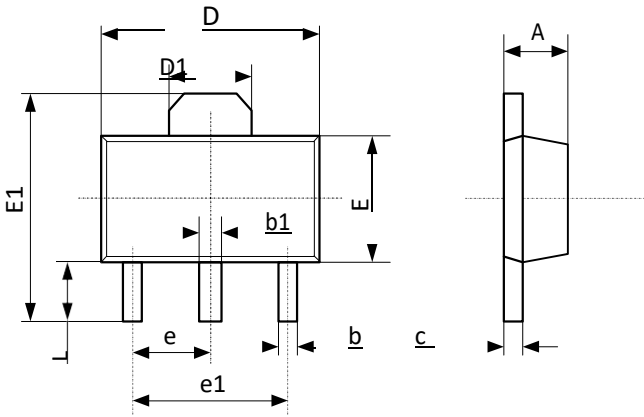
Package	SOT89-3L	Devices per reel	1000Pcs	Unit	mm
Package Dimension:					
					
Symbol	Dimensions In Millimeters		Dimensions In Inches		
	Min	Max	Min	Max	
A	1.400	1.600	0.055	0.063	
b	0.320	0.520	0.013	0.020	
b1	0.400	0.580	0.016	0.023	
c	0.350	0.440	0.014	0.017	
D	4.400	4.600	0.173	0.181	
D1	1.45	1.65	0.057	0.065	
E	2.300	2.600	0.091	0.102	
E1	3.940	4.250	0.155	0.167	
e	1.500 TYP		0.060 TYP		
e1	3.000 TYP		0.118 TYP		
L	0.900	1.200	0.035	0.047	

PACKAGE OUTLINE

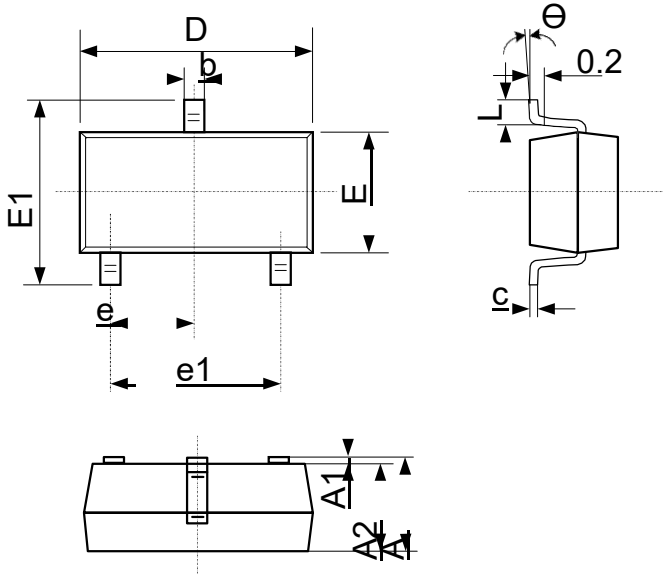
Package	SOT23-3L	Devices per reel	3000Pcs	Unit	mm
Package Dimension:					
					
Symbol	Dimensions In Millimeters		Dimensions In Inches		
	Min	Max	Min	Max	
A	1.050	1.250	0.041	0.049	
A1	0.000	0.100	0.000	0.004	
A2	1.050	1.150	0.041	0.045	
b	0.300	0.500	0.012	0.020	
c	0.100	0.200	0.004	0.008	
D	2.820	3.020	0.111	0.119	
E	1.500	1.700	0.059	0.067	
E1	2.650	2.950	0.104	0.116	
e	0.950(BSC)		0.037(BSC)		
e1	1.800	2.000	0.071	0.079	
L	0.300	0.600	0.012	0.024	
θ	0°	8°	0°	8°	

PACKAGE OUTLINE

Package	SOT23-5L	Devices per reel	3000Pcs	Unit	mm
---------	----------	------------------	---------	------	----

Package Dimension:

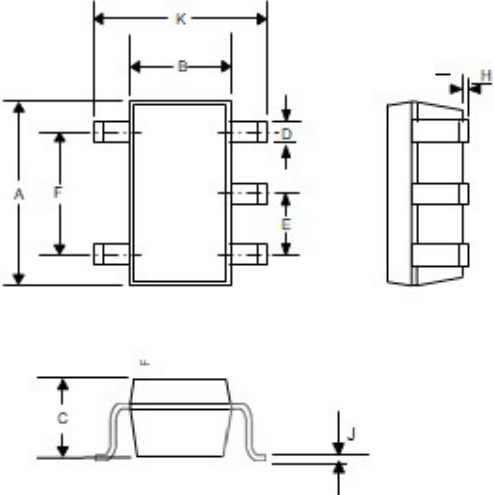

DIM ^N	INCHES		MM	
	MIN	MAX	MIN	MAX
A	0.110	0.120	2.80	3.05
B	0.059	0.070	1.50	1.75
C	0.036	0.051	0.90	1.30
D	0.014	0.020	0.35	0.50
E	-	0.037	-	0.95
F	-	0.075	-	1.90
H	-	0.006	-	0.15
J	0.0035	0.008	0.090	0.20
K	0.102	0.118	2.60	3.00

Customer Support
Seaward Electronics Incorporated – China

Section B, 2nd Floor, ShangDi Scientific Office Complex, #22 XinXi Road

Haidian District, Beijing 100085, China

Tel: 86-10-8289-5700/01/05

Fax: 86-10-8289-5706

Email: sales@seawardinc.com.cn

Seaward Electronics Incorporated – North America

1512 Centre Pointe Dr.

Milpitas, CA95035, USA

Tel: 1-650-444-0713

X-ON Electronics

Largest Supplier of Electrical and Electronic Components

Click to view similar products for [Linear Voltage Regulators](#) category:

Click to view products by [Seaward](#) manufacturer:

Other Similar products are found below :

[LV5684PVD-XH](#) [MCDTSA6-2R](#) [L7815ACV-DG](#) [LV56801P-E](#) [UA7805CKC](#) [714954EB](#) [ZMR500QFTA](#) [BA033LBSG2-TR](#)

[NCV78M05ABDTRKG](#) [LV5680P-E](#) [L79M05T-E](#) [L78LR05D-MA-E](#) [NCV317MBTG](#) [NTE7227](#) [MP2018GZD-33-P](#) [MP2018GZD-5-P](#)

[LV5680NPVC-XH](#) [ZTS6538SE](#) [UA78L09CLP](#) [UA78L09CLPR](#) [CAT6221-PPTD-GT3](#) [MC78M09CDTRK](#) [NCV51190MNTAG](#)

[BL1118CS8TR1833](#) [BL8563CKETR18](#) [BL8077CKETR33](#) [BL9153-33CC3TR](#) [BL9161G-15BADRN](#) [BL9161G-28BADRN](#)

[BRCO7530MMC](#) [CJ7815B-TFN-ARG](#) [LM317C](#) [GM7333K](#) [GM7350K](#) [XC6206P332MR](#) [HT7533](#) [LM7912S/TR](#) [LT1764S/TR](#) [LM7805T](#)

[LM338T](#) [LM1117IMP-3.3/TR](#) [HT1117AM-3.3](#) [HT7550S](#) [AMS1117-3.3](#) [HT7150S](#) [78L12](#) [HT7550](#) [HT7533-1](#) [HXY6206I-2.5](#) [HT7133](#)