



General Description

The SE8801 is a very low dropout three-terminal regulator and specifically designed for today's electricity meter applications. There are two distinct requirements for the power supplies for the electricity meters. The first requirement is low power consumption. The second is low noise. Most of the power supplies in the market could only satisfy one requirement, but not both of them at the same time. The SE8801 is now the first IC in the market that is able to satisfy both requirements. The SE8801 uses a very unique design to achieve very low power consumption while providing a very low noise power output for electricity meter applications.

Features

- Output voltage of 3.3/4.3/5.0V/5.7 (Typ.)
- Low quiescent Current
- Over-current/Over-temperature Protection.
- Minimum external components.
- Output voltage tolerances of 4.3V $\pm 1\%$
- Output voltage tolerances of 3.3V/5.0V/5.7V $\pm 2\%$
- ESD rating is 2KV (Per MIL-STD-883D)
- Input Voltage up to 30V
- Operating Junction Temperature from -40°C to $+125^{\circ}\text{C}$

Pin Configuration

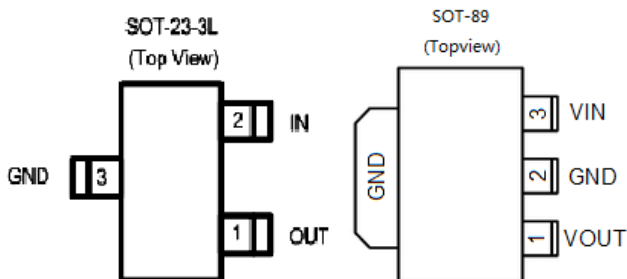

Applications

- Electricity meter.
- Networking Equipments where low noise and low power consumption is required.

Typical Application

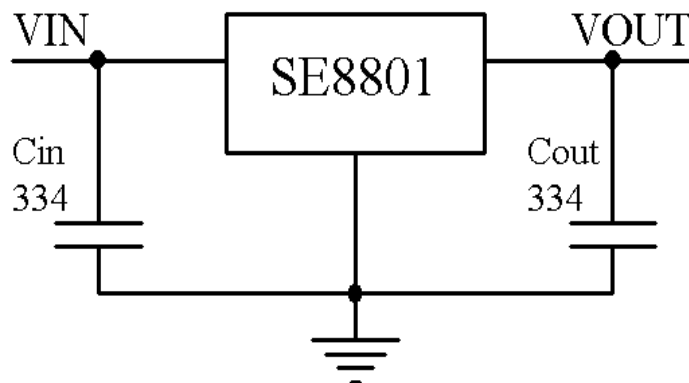



Functional Block Diagram

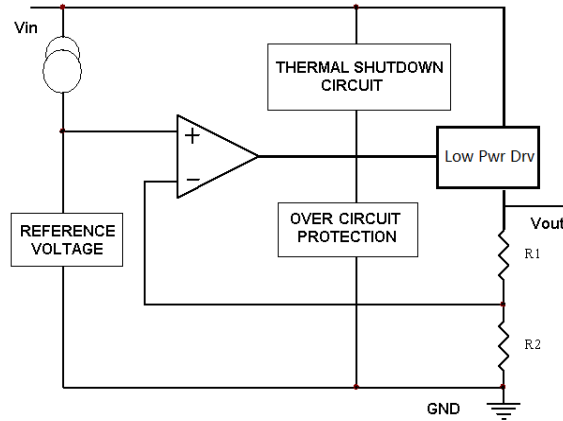

Ordering Information

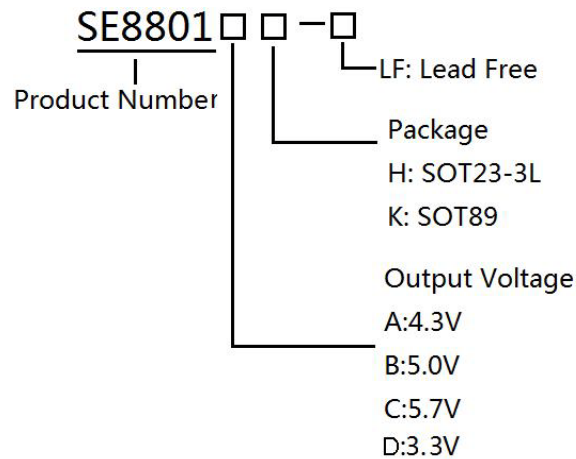

Marking Information

Part Number	Marking Information	Package	Remarks
SE8801BH	801x [●]	SOT-23-3L	The last character: the batch number.
SE8801AK	SE8801A YYWW-LF	SOT-89	A: 4.3V
SE8801BK	SE8801B YYWW-LF		B: 5.0V
SE8801CK	SE8801C YYWW-LF		C: 5.7V
SE8801DK	SE8801D YYWW-LF		D: 3.3V
			LF : Lead Free YYWW: Production batch



Absolute Maximum Rating

Parameter	Symbol	Maximum	Units
Power dissipation@25°C: SE8801H(SOT-23-3L) SE8801K(SOT-89)	P_D	0.25 0.45	W
Input Voltage	V_{IN}	-0.3~30	V
Operating Junction Temperature Range	T_J	-40 to +125	°C
Thermal Resistance SE8801H(SOT-23-3L) SE8801K(SOT-89)	θ_{JA}	150 95	°C/W
Lead Temperature (Soldering) 10 seconds	T_{LEAD}	260 ± 5	°C
Storage Temperature	T_{STG}	-65 to +150	°C
ESD (HBM) Susceptibility	V_{ESD}	2	KV

Note: 1) Thermal resistance test board Size: 5mm*5mm*1.6mm, $T_a=25^\circ\text{C}$;

Recommended Operating Conditions

Parameter	Symbol	Value	Units
Supply Input Voltage	V_{IN}	7.0 to +25	V
Junction Temperature	T_J	-40 to +85	°C

Electrical Characteristics

$V_{IN} = 8\text{V}$; $I_{OUT} = 10\text{mA}$; $C_{IN} = C_{OUT} = 1\mu\text{F}$; $T_J = 25^\circ\text{C}$; unless otherwise specified

Symbol	Parameter	Conditions	SE8801			Unit
			Min	Typ	Max	
V_O	Output Voltage	$I_{OUT} = 10\text{mA}$	- 1%	4.3	+ 1%	V
			- 2%	3.3	+ 2%	V
			- 2%	5.0	+ 2%	V
			- 2%	5.7	+ 2%	V
ΔV_O	Line Regulation	$7\text{V} \leq V_{IN} \leq 20\text{V}$	--	0.07	--	%/V
ΔV_O	Load Regulation	$1\text{mA} \leq I_O \leq 50\text{mA}$	--	50	--	mV



I_Q	Quiescent Current		--	0.65	--	mA
ΔI_Q	Quiescent Current Change	$7V \leq V_{IN} \leq 20V$	--	0.32	--	mA
		$1mA \leq I_O \leq 50mA$	--	-0.17	--	mA
Vdrop	Dropout Voltage	$\Delta V_O = -2\%$	-	0.8	--	V
$\Delta V_{IN} / \Delta V_{OUT}$	Ripple Rejection	f = 120Hz, C _{IN} =C _{OUT} =0.33uF 8V ≤ V _{IN} ≤ 16V	--	55	--	dB
I_{PK}	Peak Output Current	V _{in} =8V	50	60	--	mA
		V _{in} =15V	90	100	--	
$\Delta V_O / \Delta T$	Average Output Voltage Tempco	I _O = 10mA	--	0.10	--	mV/°C
T _{OTP}	Thermal Protection Temperature		--	130	--	°C
V _{IN} (Min)	Minimum Value of Input Voltage Required to Maintain Line Regulation	I _O = 10mA	5.8	6.2	--	V



Typical Performance Characteristic

$V_{IN} = 8V$, $I_{OUT} = 10mA$, $C_{IN} = C_{OUT} = 0.33\mu F$, $T_J = 25^\circ C$, unless specified otherwise.

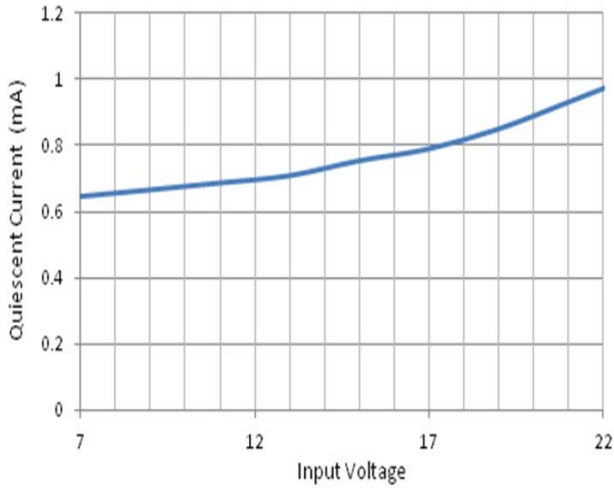

Quiescent Current VS Input Voltage

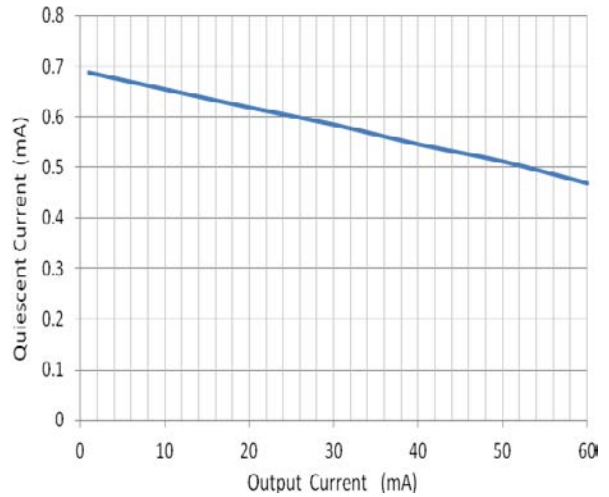

Quiescent Current VS Output Current

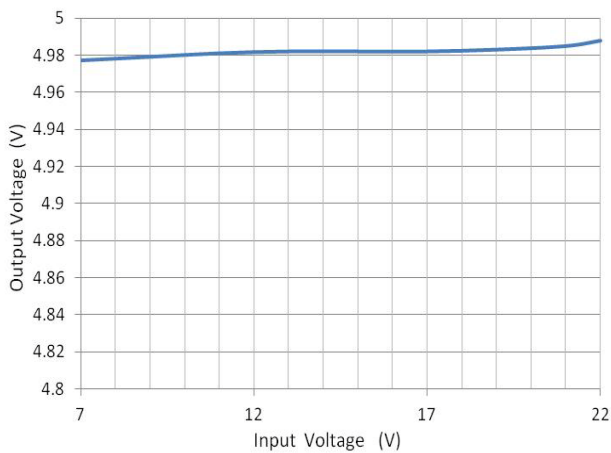

Output Voltage VS Input Voltage

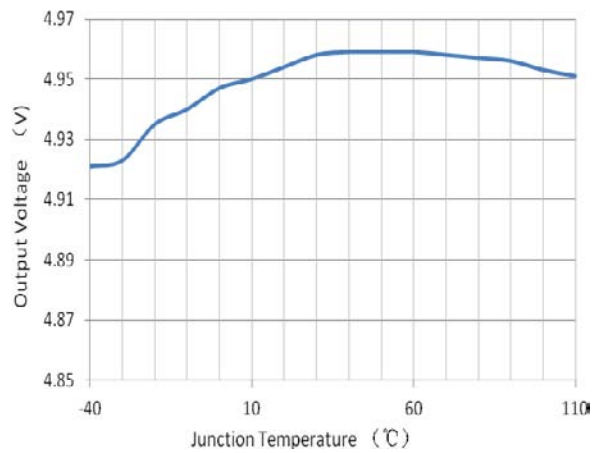

Output Voltage VS Junction Temperature

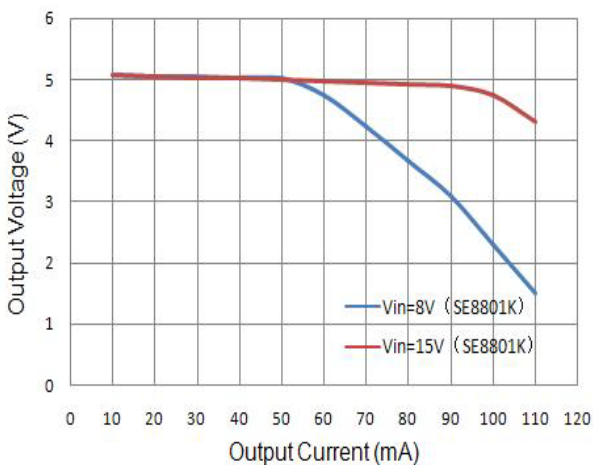

Output Voltage VS Output Current

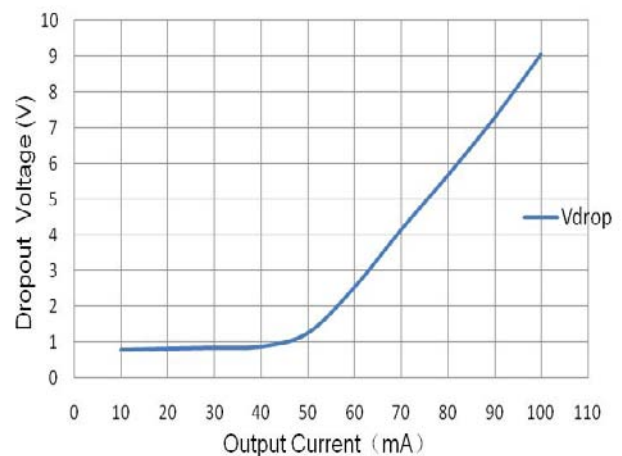

Dropout Voltage VS Output Current



Outline Drawing SOT-23

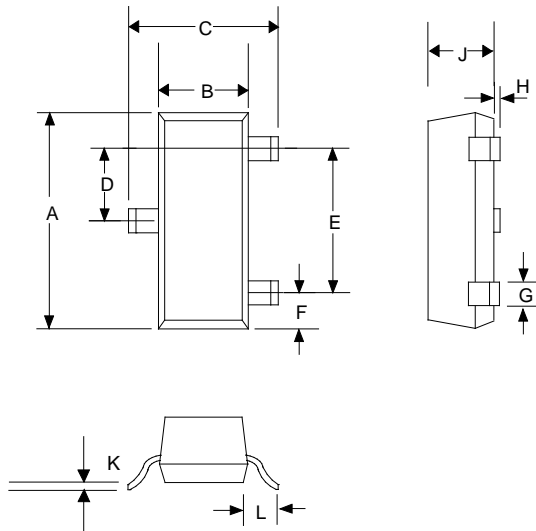

DIMENSIONS				
DIM ^N	INCHES		MM	
	MIN	MAX	MIN	MAX
A	0.110	0.120	2.80	3.04
B	0.047	0.055	1.20	1.40
C	0.083	0.104	2.10	2.64
D	0.035	0.040	0.89	1.03
E	0.070	0.080	1.78	2.05
F	0.018	0.024	0.45	0.60
G	0.015	0.020	0.37	0.51
H	0.0005	0.004	0.013	0.10
J	0.034	0.040	0.887	1.02
K	0.003	0.007	0.085	0.18
L	-	0.027	-	0.69

Outline Drawing SOT-89

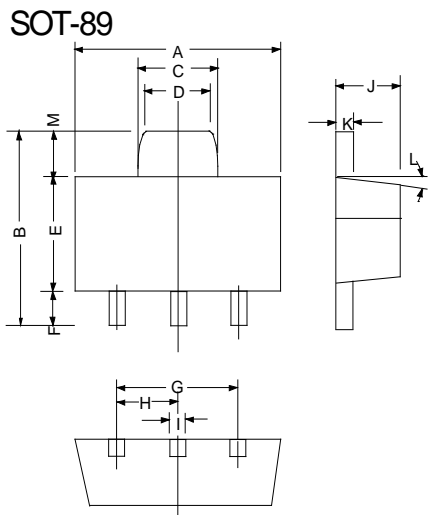

DIMENSIONS				
DIM ^N	INCHES		MM	
	MIN	MAX	MIN	MAX
A	0.173	0.181	4.400	4.600
B	0.159	0.167	4.050	4.250
C	0.067	0.075	1.700	1.900
D	0.051	0.059	1.300	1.500
E	0.094	0.102	2.400	2.600
F	0.035	0.047	0.890	1.200
G	0.118REF		3.00REF	
H	0.059REF		1.50REF	
I	0.016	0.020	0.400	0.520
J	0.055	0.063	1.400	1.600
K	0.014	0.016	0.350	0.410
L	10°TYP		10°TYP	
M	0.028REF		0.70REF	



联系方式:

北京思旺电子有限公司-中国总部

地址: 中国北京市海淀区信息路 22 号上地科技综合楼 B 座二层

邮编: 100085

电话:010-82895700/1/5

传真:010-82895706

Seaward Electronics Corporation – 台湾办事处

2F, #181, Sec. 3, Minguan East Rd,

Taipei, Taiwan R.O.C

电话: 886-2-2712-0307

传真: 886-2-2712-0191

Seaward Electronics Incorporated – 北美办事处

1512 Centre Pointe Dr.

Milpitas, CA95035, USA

电话: 1-408-821-6600

X-ON Electronics

Largest Supplier of Electrical and Electronic Components

Click to view similar products for [LDO Voltage Regulators](#) category:

Click to view products by [Seaward](#) manufacturer:

Other Similar products are found below :

[AP7363-SP-13](#) [L79M05TL-E](#) [AP7362-HA-7](#) [PT7M8202B12TA5EX](#) [TCR3DF185,LM\(CT](#) [TCR3DF45,LM\(CT](#) [TLE4473G V52](#) [059985X](#)
[NCP4687DH15T1G](#) [701326R](#) [NCV8170AXV250T2G](#) [AP7315-25W5-7](#) [AP2111H-1.2TRG1](#) [ZLDO1117QK50TC](#) [AZ1117ID-ADJTRG1](#)
[TCR3DG12,LF](#) [MIC5514-3.3YMT-T5](#) [SCD7912BTG](#) [NCP154MX180270TAG](#) [SCD33269T-5.0G](#) [NCV8170BXV330T2G](#)
[NCV8170BMX330TCG](#) [NCV8170AMX120TCG](#) [NCP706ABMX300TAG](#) [NCP153MX330180TCG](#) [NCP114BMX075TCG](#) [MC33269T-3.5G](#)
[CAT6243-ADJCMT5T](#) [TCR3DG33,LF](#) [TCR4DG35,LF](#) [TAR5S15U\(TE85L,F\)](#) [TAR5S18U\(TE85L,F\)](#) [TCR3UG19A,LF](#) [TCR4DG105,LF](#)
[MPQ2013AGG-5-P](#) [NCV8170AMX360TCG](#) [TLE4268GSXUMA2](#) [NCP715SQ15T2G](#) [MIC5317-3.0YD5-T5](#) [NCV563SQ18T1G](#)
[NCP715MX30TBG](#) [NCV8702MX25TCG](#) [NCV8170BXV120T2G](#) [MIC5317-1.2YD5-T5](#) [NCV8170AMX150TCG](#) [NCV8170BMX150TCG](#)
[AP2213D-3.3TRG1](#) [NCV8170BMX120TCG](#) [NCV8170BMX310TCG](#) [NCV8170BMX360TCG](#)