

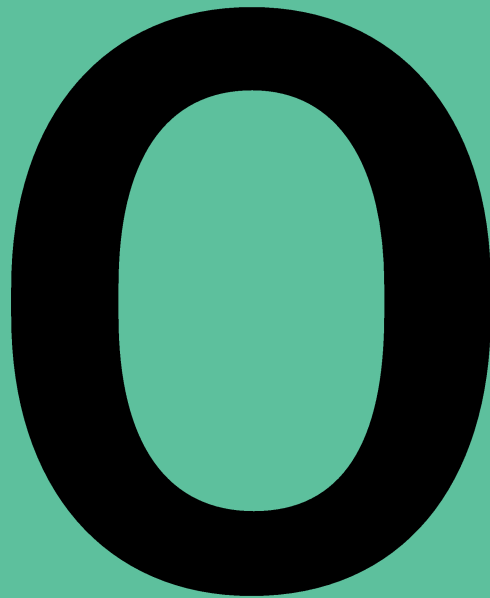

SAMSUNG
ARTIK[™] Modules



ARTIK 053 Starter Kit HW Guide

TABLE OF CONTENTS

TABLE OF CONTENTS	2
LIST OF FIGURES	3
LIST OF TABLES	4
VERSION HISTORY	5
INTRODUCTION	6
OVERVIEW	6
<i>BOARD INTERFACES</i>	6
<i>SIGNAL AND HEADER BLOCK DIAGRAM</i>	7
POWER CONFIGURATION AND OPTIONS	8
<i>POWER CONFIGURATION (CON705 HEADER)</i>	8
<i>USB 2.0 (CON700 HEADER)</i>	8
<i>DC POWER JACK (CON712 HEADER)</i>	9
<i>BATTERY POWER (CON706 HEADER)</i>	9
BUTTONS AND LEDs.....	10
<i>STARTER KIT BUTTONS</i>	10
<i>STARTER KIT LEDs</i>	10
ARTIK 053 I/O SIGNAL BREAK-OUT	11
<i>ARDUINO SHIELD INTERFACE 1 AND 2 (CON708-CON709 HEADERS)</i>	11
<i>ARDUINO SHIELD INTERFACE RESET AND ADC (CON710-CON711 HEADER)</i>	12
<i>ARTIK 053 I/O SIGNAL BREAK-OUT-1 (CON703 HEADER)</i>	13
<i>ARTIK 053 I/O SIGNAL BREAK-OUT-2 (CON704 HEADER)</i>	13
JTAG INTERFACE	14
<i>JTAG (CON707 HEADER)</i>	14
STARTER KIT BOARD MECHANICAL DIMENSIONS.....	15
INTERPOSER BOARD DESCRIPTION.....	16
<i>CON701 HEADER SIGNALS</i>	17
<i>CON702 HEADER SIGNALS</i>	18
INTERPOSER BOARD MECHANICAL DIMENSIONS.....	19
HANDLING GUIDE	20
LEGAL INFORMATION	21

LIST OF FIGURES

Figure 1. Board interfaces	6
Figure 2. Signal and header block diagram	7
Figure 3. Power settings jumper location	8
Figure 4. USB 2.0 interface connector location.....	8
Figure 5. DC Jack connector location.....	9
Figure 6. Battery connector location	9
Figure 7. Switch locations.....	10
Figure 8. LED locations.....	10
Figure 9. Arduino connectors location.....	11
Figure 10. Reset and ADC connector location.....	12
Figure 11. 053 Signal break-out 2 location	13
Figure 12. 053 Signal break-out 1 location	13
Figure 13. JTAG connector location	14
Figure 14. JTAG to SWD cable and adapter	14
Figure 15. Mechanical Dimensions ARTIK 053 Starter Kit.....	15
Figure 16. Interposer to Starter Board connectors	16
Figure 17. Interposer connector location	17
Figure 18. Interposer connector location.....	18
Figure 19. Mechanical Dimensions Interposer Board	19

LIST OF TABLES

Table 1. Power Configuration (CON705 Header).....	8
Table 2. USB2.0 (CON700 Header)	8
Table 3. DC POWER JACK (CON712 HEADER).....	9
Table 4. Battery Power (CON706 Header)	9
Table 5. Button descriptions	10
Table 6. LED descriptions	10
Table 7. Arduino Shield 1 (CON708 Header).....	11
Table 8. Arduino Shield 2 (CON709 Header).....	11
Table 9. Arduino Shield Reset (CON710).....	12
Table 10. Arduino Shield ADC (CON711).....	12
Table 11. ARTIK 053 I/O Signal Break-out 1 (CON703 Header).....	13
Table 12. ARTIK 053 I/O Signal Break-out 2 (CON704 Header).....	13
Table 13. JTAG (CON707).....	14
Table 14. CON400 signal description	16
Table 15. CON401 signal description	16
Table 16. CON701 signal description	17
Table 17. CON702 signal description	18

VERSION HISTORY

Revision	Date	Description	Maturity
V1.0	5/5/2017	First release	Release

INTRODUCTION

The Samsung ARTIK™ 053 Starter Kit provides a development platform for the Samsung ARTIK 053 Module. This document describes Starter Kit button and LED usage, I/O pinout, and power connections. For information about starting development, see the “ARTIK 053 Getting Started Guide”. For more information about the ARTIK 053 Module, see the “ARTIK 053 Datasheet”.

OVERVIEW

BOARD INTERFACES

The ARTIK 053 Starter Kit consists of a Starter Kit Board, an Interposer Board, and an ARTIK 053 Module. The ARTIK 053 Module is soldered to the Interposer Board which serves as a carrier for the ARTIK 053 Module. The Interposer Board plugs into the Starter Kit Board. *Figure 1* shows an overview of its debug and I/O interface headers. Subsequent sections show the header interfaces in greater detail.

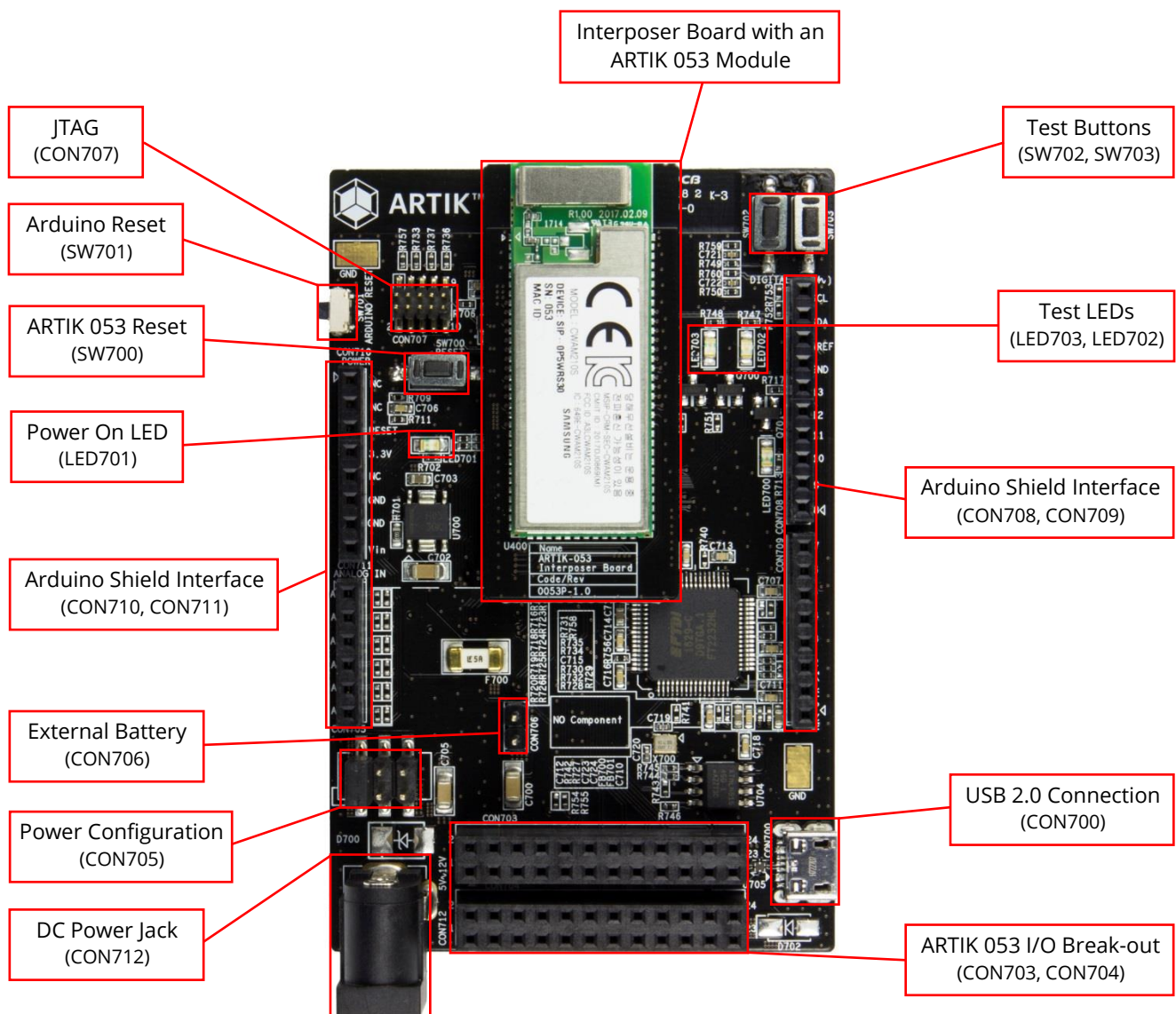

Figure 1. Board interfaces

SIGNAL AND HEADER BLOCK DIAGRAM

Figure 2 shows the block diagram of how the signals and headers of the ARTIK 053 Starter Kit are connected. For more information on the ARTIK 053 Module, consult the ARTIK 053 Module Datasheet.

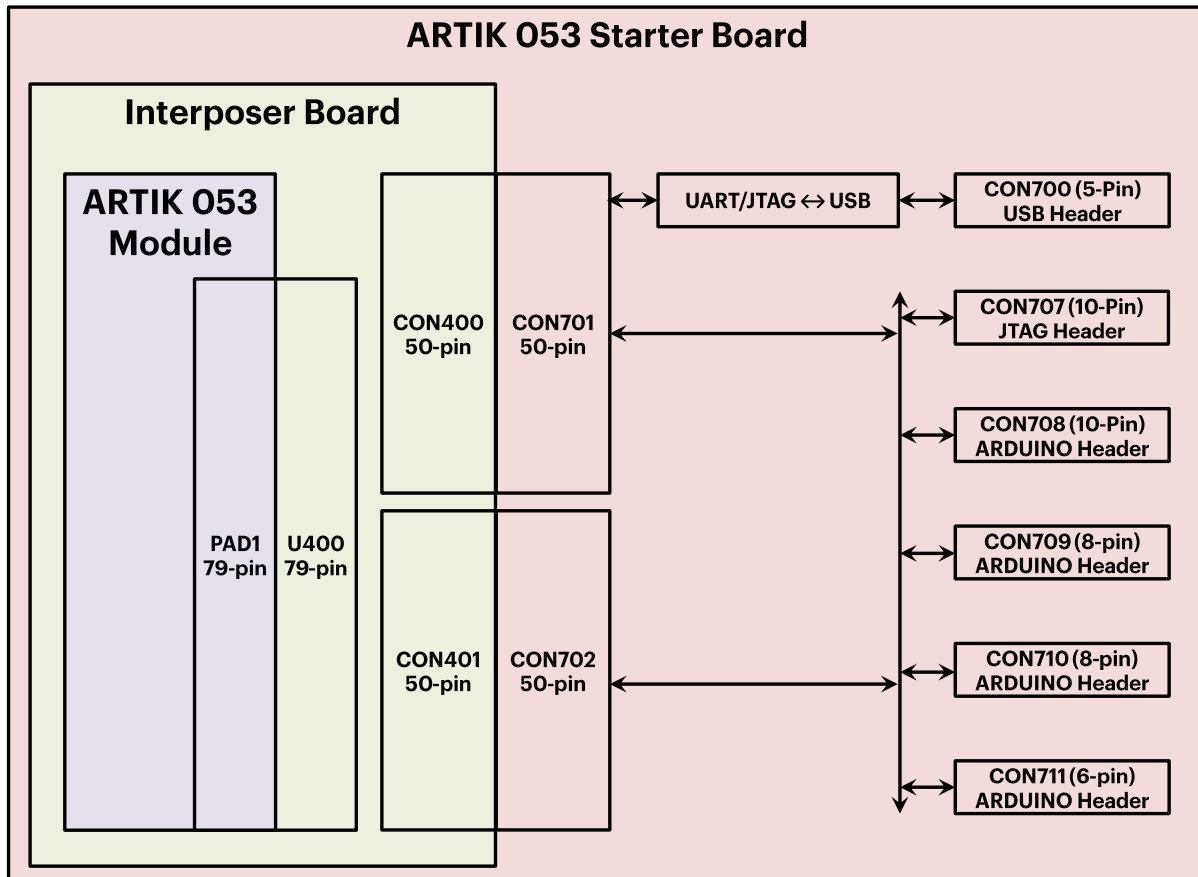

Figure 2. Signal and header block diagram

POWER CONFIGURATION AND OPTIONS

POWER CONFIGURATION (CON705 HEADER)

Power to the ARTIK 053 Starter Kit can be sourced from the USB (default) connector, a 5-12V DC Jack or alternate 5.6-6.4V battery power. *Table 1* shows the jumper settings to select each of the power sources.

Table 1. Power Configuration (CON705 Header)

Pin Number	Description	Comment
1 - 2	VCC_USB5P0	USB Connector Power Source
3 - 4	DCJack	DC Jack Power Source
5 - 6	Battery	External Battery Power Source

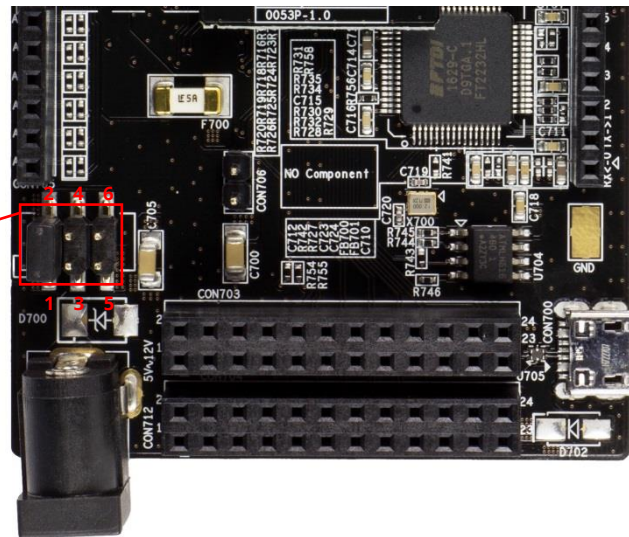

Power Configuration (CON705)

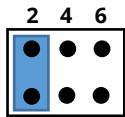

USB Connector Power (Default)

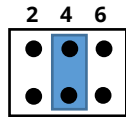

DC Power Jack

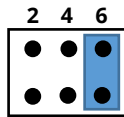

External Battery Power

Figure 3. Power settings jumper location

USB 2.0 (CON700 HEADER)

Table 2. USB2.0 (CON700 Header)

Pin Number	Signal	Description
1	VBUS	VCC_USB5P0 Power
2	D-	Data Minus
3	D+	Data Plus
4	NC	Not Connected
5	GND	Ground
6	GND	Ground
7	GND	Ground
8	GND	Ground
9	GND	Ground
10	GND	Ground
11	GND	Ground

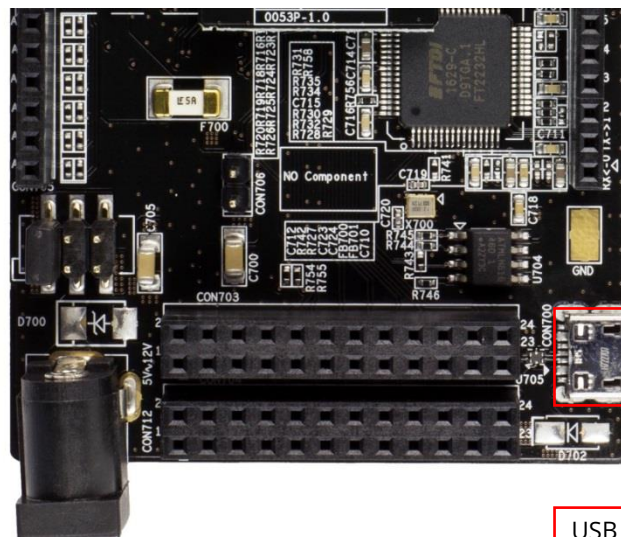

USB 2.0 Connection (CON700)

Figure 4. USB 2.0 interface connector location

DC POWER JACK (CON712 HEADER)

Table 3. DC POWER JACK (CON712 HEADER)

Pin Number	Description	Comment
1	VCC	5V-12V DC power
2	GND	Ground
3	GND	Ground

DC Power Jack (CON712)

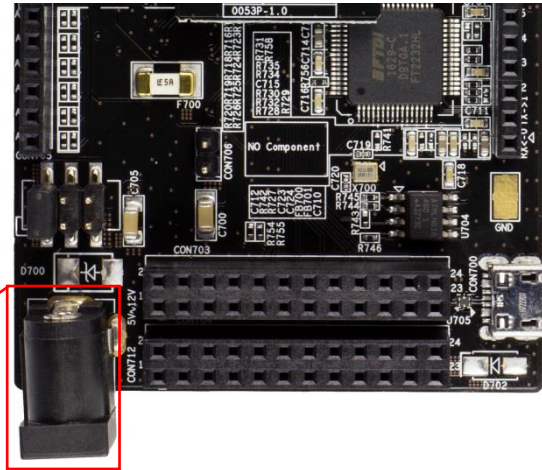

Figure 5. DC Jack connector location

BATTERY POWER (CON706 HEADER)

Pins are provided for connecting an alternative external power source with CON706. [Table 4](#) and [Figure 6](#) show the details.

Table 4. Battery Power (CON706 Header)

Pin Number	Description	Comment
1	Plus (Square pad)	5V-12V External Battery Power. Example, 4 AA batteries
2	GND (Round pad)	Ground

External Battery (CON706)

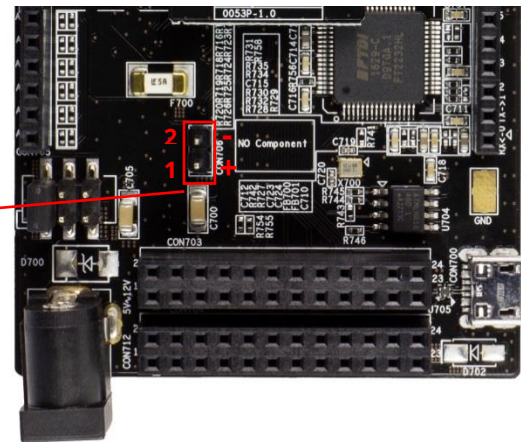

Figure 6. Battery connector location

BUTTONS AND LEDs

This section describes the buttons and LEDs that are available on the Starter Kit board.

STARTER KIT BUTTONS

Table 5. Button descriptions

Button Name	Description	Comment
SW700	ARTIK 053 Reset Button	Connects signal XRESET_N to GND on CON702 (pin 1 and 21). See Table 17 for more details.
SW701	Arduino Reset Button	A reset signal on Arduino interface. The reset signal is part of CON710. See Table 9 for more details.
SW702	Test Button 2	When pressed, SW702 connects signal XGPIO13 to GND. Can be used for application specific input.
SW703	Test Button 1	When pressed, SW703 connects signal XGPIO15 to GND. Can be used for application specific input.

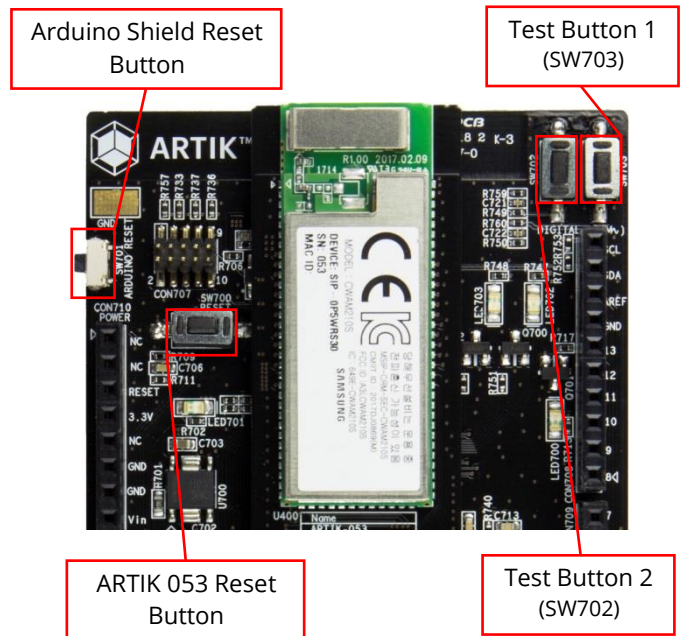

Figure 7. Switch locations

STARTER KIT LEDs

Table 6. LED descriptions

LED Name	Description	Comment
LED700	Arduino Shield LED	This red LED is illuminated from pin 6 of Arduino Shield 1 Header CON708. Is used by Arduino Shield applications. See Table 7 for more details.
LED701	ARTIK 053 Power	This red LED is illuminated whenever Starter Kit board power is applied.
LED702	Test LED 1	This blue LED is connected to signal XGPIO20. Can be used for application specific output.
LED703	Test LED 2	This red LED is connected to signal XGPIO16. Can be used for application specific output.

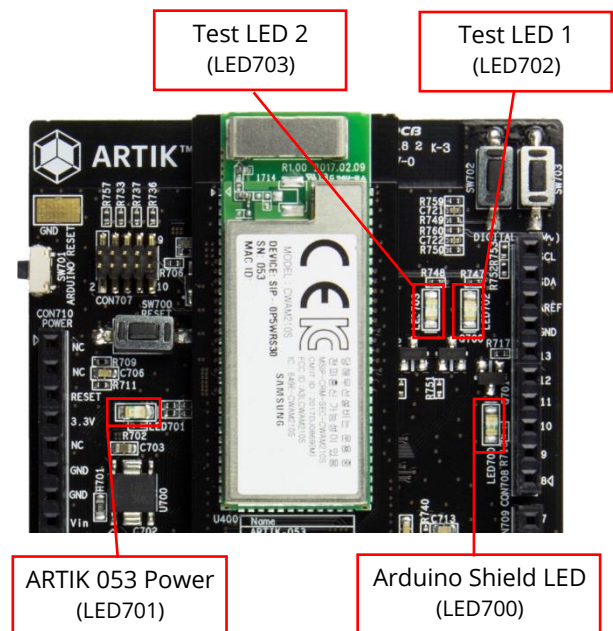

Figure 8. LED locations

ARTIK 053 I/O SIGNAL BREAK-OUT

ARDUINO SHIELD INTERFACE 1 AND 2 (CON708-CON709 HEADERS)

CON708 and CON709 contain the standard Arduino® Due Shield interface. Some of the Shield signals are the identical functionality from the ARTIK 053 I/O signals, and are reused for the same operation in the Shield interface. Therefore, when not used as Shield interface signals, these pins give access to the ARTIK 053 functionality instead. The '*' note indicates the different Arduino/ARTIK signal names for the same or different functionality. Those signals that don't a '*' note are ARTIK specific. Details are shown in *Figure 9*, *Table 7* and *Table 8*.

Table 7. Arduino Shield 1 (CON708 Header)

Pin Number	Description
10	SCL1 - XI2C0_SCL*
9	SDA1 - XI2C0_SDA*
8	AREF - Not Connected**
7	GND - GND*
6	D13 - XSPI1_CLK*
5	D12 - XSPI1_MISO*
4	D11 - XSPI1_MOSI*
3	D10 - XSPI1_CSN*
2	D9 - XPWMOUT_4*
1	D8 - XGPIO21*

Table 8. Arduino Shield 2 (CON709 Header)

Pin Number	Description
8	D7 - XGPIO19*
7	D6 - XPWMOUT_2*
6	D5 - XPWMOUT_1*
5	D4 - XGPIO18*
4	D3 - XPWMOUT_0*
3	D2 - XGPIO17*
2	TX0 - XUART0_TXD*
1	RX0 - XUART0_RXD*

* Arduino Shield functionality - ARTIK 053 functionality.
 ** Arduino Shield specific.

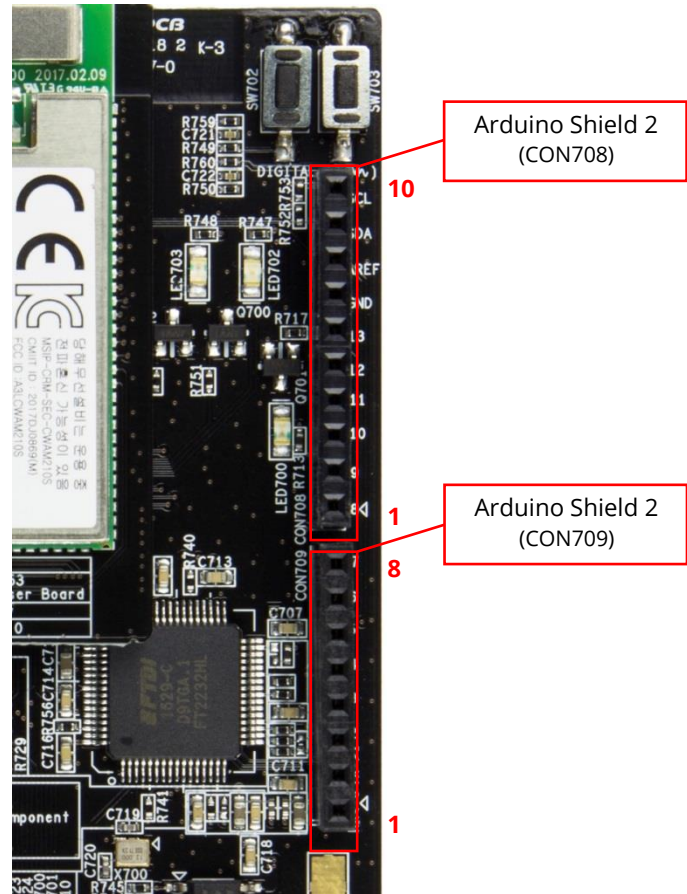

Figure 9. Arduino connectors location

ARDUINO SHIELD INTERFACE RESET AND ADC (CON710-CON711 HEADER)

CON710 and CON711 carry the standard Arduino® Due Shield interface. Some of the Shield signals are the identical functionality from the ARTIK 053 I/O signals, and are reused for the same operation in the Shield interface. Therefore, when not used as Shield interface signals, these pins give access to the ARTIK 053 functionality instead. The ‘*’ note indicates the different Arduino/ARTIK signal names for the same functionality. Those signals that don’t a ‘*’ note are either ARTIK specific. Details are shown in *Figure 10*, *Table 7* and *Table 8*.

Table 9. Arduino Shield Reset (CON710)

Pin Number	Description
1	Not Used
2	IOREF - Not Connected**
3	RESET**
4	VCC_EXT3P3 - VCC_EXT3P3*
5	5V - Not Connected*
6	GND / GND*
7	GND / GND*
8	VIN - Not Connected**

Table 10. Arduino Shield ADC (CON711)

Pin Number	Description
1	A0 - XADC0AIN_0*
2	A1 - XADC0AIN_1*
3	A2 - XADC0AIN_2*
4	A3 - XADC0AIN_3*
5	GP60 - XGPIO23*
6	GP61 - XGPIO22*

* Arduino Shield functionality - ARTIK 053 functionality.
 ** Arduino Shield specific.

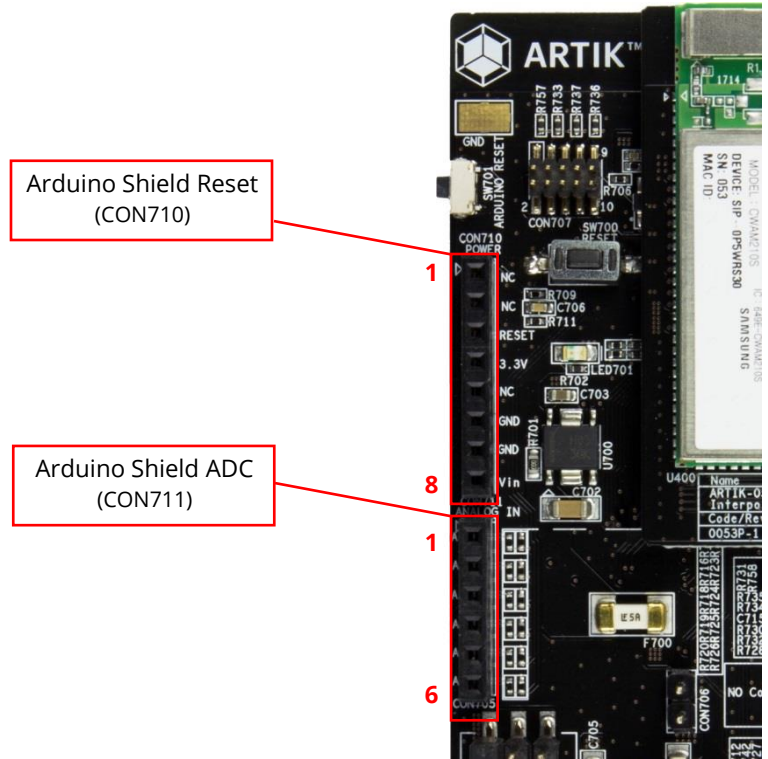

Figure 10. Reset and ADC connector location

ARTIK 053 I/O SIGNAL BREAK-OUT-1 (CON703 HEADER)

CON703 header signals can be found in [Table 11](#). CON703 and CON704 bring out the remaining ARTIK 053 I/O functionality that isn't brought out by the Arduino interface headers.

Table 11. ARTIK 053 I/O Signal Break-out 1 (CON703 Header)

Pin Number	Description	Pin Number	Description
1	XPWMOUT_1	2	VCC_EXT3P3
3	XPWMOUT_2	4	Not Connected
5	XPWMOUT_3	6	Not Connected
7	XPWMOUT_0	8	XI2C1_SCL
9	XUART1_RXD	10	XI2C1_SDA
11	XUART1_TXD	12	GND
13	XGPIO26	14	VCC_EXT3P3
15	XGPIO25	16	XSPI0_CLK
17	XGPIO24	18	XSPI0_CS
19	XGPIO23	20	XSPI0_MISO
21	XGPIO22	22	XSPI0_MOSI
23	XEINT0	24	GND

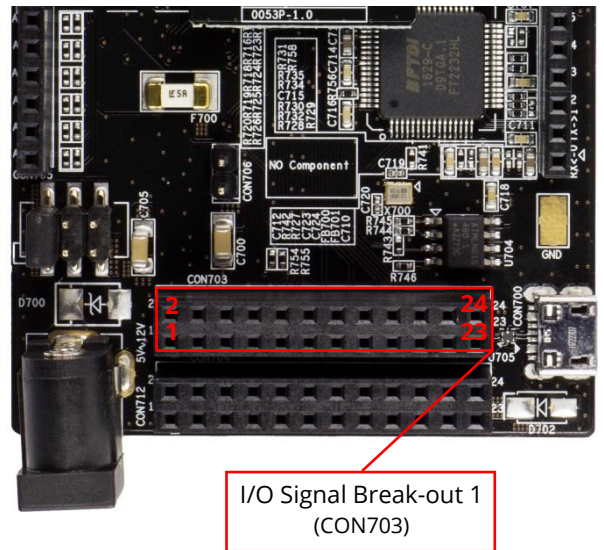

Figure 11. 053 Signal break-out 2 location

ARTIK 053 I/O SIGNAL BREAK-OUT-2 (CON704 HEADER)

CON704 header signals can be found in [Table 12](#). CON703 and CON704 bring out the remaining ARTIK 053 I/O functionality that isn't brought out by the Arduino interface headers.

Table 12. ARTIK 053 I/O Signal Break-out 2 (CON704 Header)

Pin Number	Description	Pin Number	Description
1	XPWMTOUT_4	2	VCC_EXT3P3
3	XPWMTOUT_5	4	XUART2_RXD
5	XEINT2	6	XUART2_TXD
7	XEINT1	8	XUART3_RXD
9	XGPIO12	10	XUART3_TXD
11	XGPIO10	12	GND
13	XGPIO9	14	VCC_EXT3P3
15	XGPIO11	16	XGPIO4
17	XGPIO8	18	XGPIO5
19	XGPIO2	20	XGPIO6
21	XGPIO1	22	XGPIO7
23	XGPIO3	24	GND

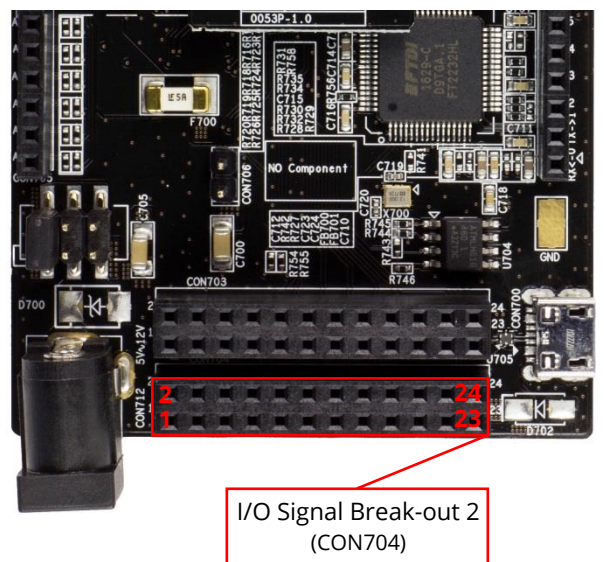

Figure 12. 053 Signal break-out 1 location

JTAG INTERFACE

JTAG (CON707 HEADER)

CON707 provides a JTAG interface that can be used with trace and debugging equipment. Connector detail is described in [Table 13](#) and [Figure 13](#). [Figure 14](#) shows a JTAG to SWD interface cable/adapter to convert from the mini-JTAG connector to a common SWD connector used by many trace/debug instruments. The cable/adapter set shown is available from [Adafruit®](#).

Table 13. JTAG (CON707)

Pin Number	Description	Pin Number	Description
1	VCC_EXT3P3	2	XJTAG_TMS
3	GND	4	XJTAG_TCK
5	GND	6	XJTAG_TDO
7	NC	8	XJTAG_TDI
9	GND	10	XJTAG_TRST_N

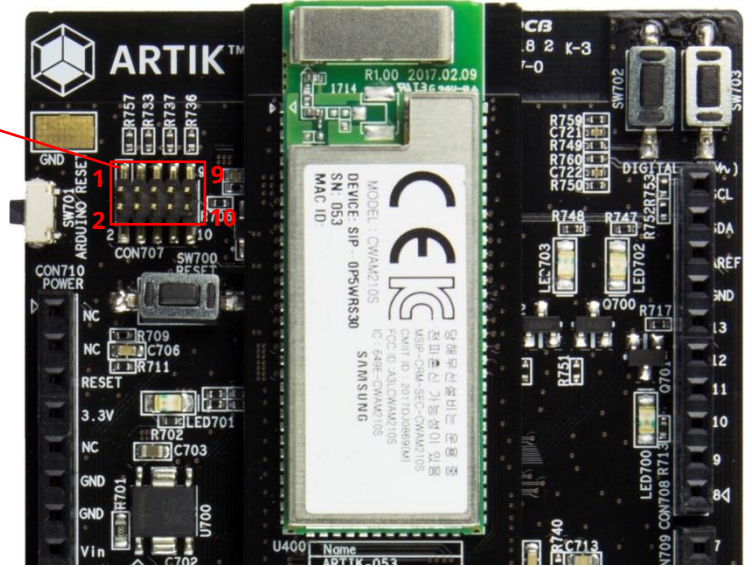

Figure 13. JTAG connector location

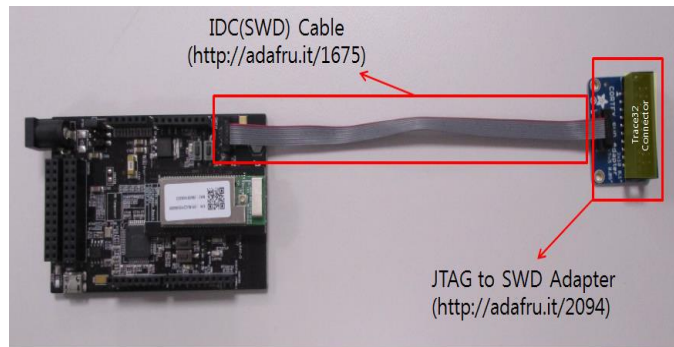

Figure 14. JTAG to SWD cable and adapter

STARTER KIT BOARD MECHANICAL DIMENSIONS

Figure 15 shows the mechanical dimensions of the ARTIK 053 Starter Kit Board.

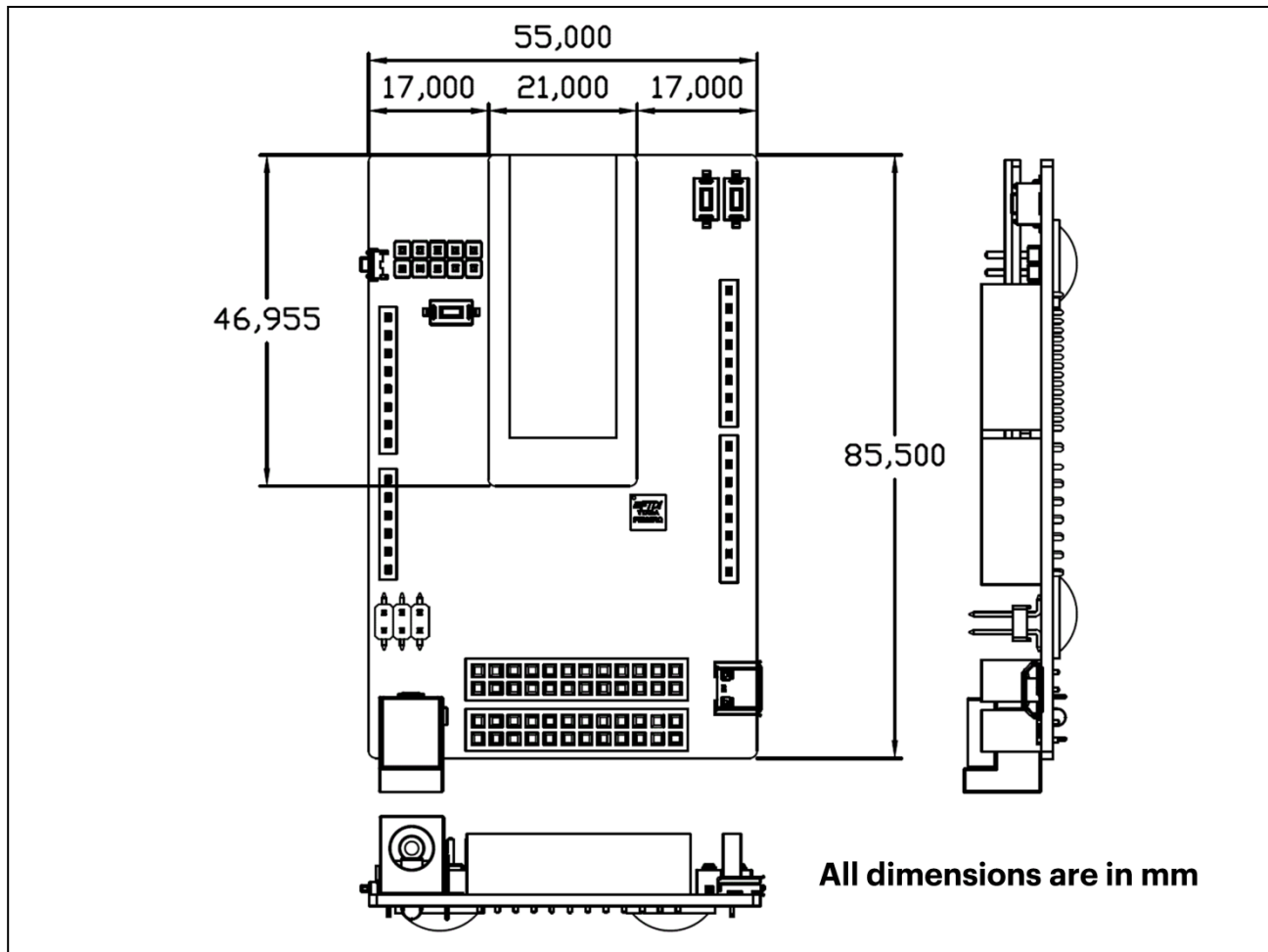

Figure 15. Mechanical Dimensions ARTIK 053 Starter Kit

INTERPOSER BOARD DESCRIPTION

The Interposer Board is the bridge between the Starter Board and the ARTIK 053 Module, with the ARTIK 053 Module soldered directly to the top of the Interposer Board. Interposer connectors CON400 and CON401 on the Interposer Board are connected to Interposer connectors CON701 and CON702 on the Starter Board.

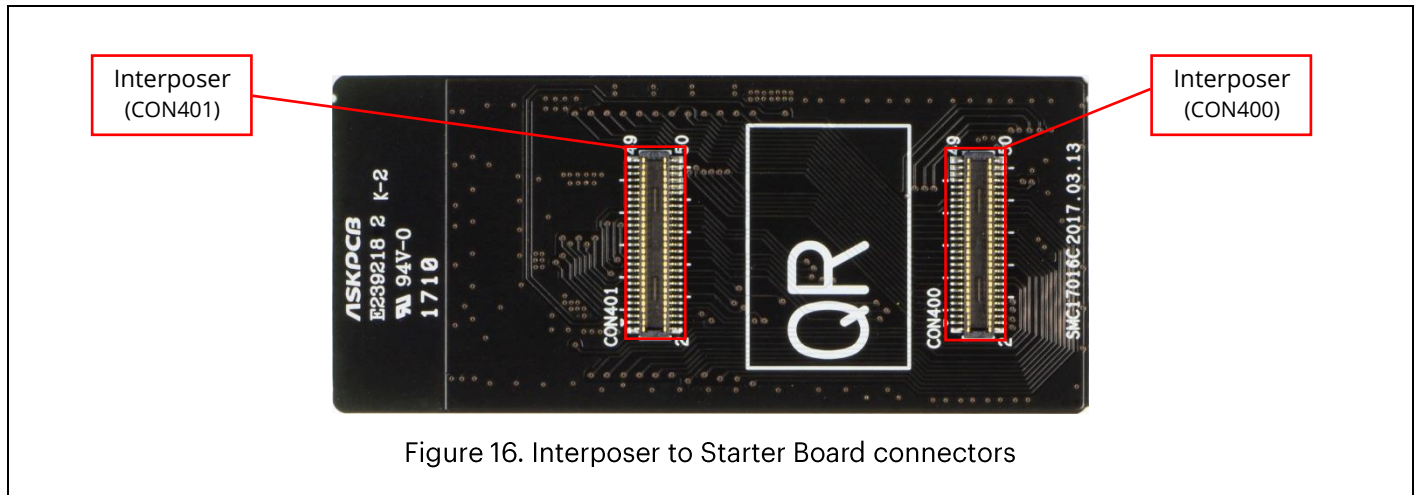

Figure 16. Interposer to Starter Board connectors

Table 14. CON400 signal description

Connector CON400			
Pin Name	Description	Pin Name	Description
1	XGPIO26	2	XSPI1_CSN
3	XGPIO25	4	XSPI1_MOSI
5	XGPIO24	6	XSPI1_CLK
7	XGPIO21	8	XSPI1_MISO
9	XGPIO19	10	GND
11	XGPIO18	12	Not Connected
13	XGPIO17	14	XGPIO3
15	XGPIO14	16	XGPIO1
17	XGPIO13	18	GND
19	XGPIO16	20	XGPIO5
21	XGPIO15	22	XGPIO4
23	XGPIO20	24	XGPIO2
25	GND	26	XGPIO7
27	XADC0AIN_0	28	XGPIO8
29	XADC0AIN_1	30	XGPIO6
31	XADC0AIN_2	32	GND
33	XADC0AIN_3	34	XGPIO11
35	GND	36	XGPIO9
37	XGPIO23	38	XGPIO10
39	XGPIO22	40	XGPIO12
41	Not Connected	42	GND
43	Not Connected	44	XUART3_TXD
45	GND	46	XUART3_RXD
47	GND	48	GND
49	GND	50	GND

Table 15. CON401 signal description

Connector CON401			
Pin Name	Description	Pin Name	Description
1	XRESET_N	2	XUART2_TXD
3	XJTAG_TMS	4	XUART2_RXD
5	XJTAG_TDI	6	XUART1_RXD
7	XJTAG_TCK	8	XUART1_TXD
9	XJTAG_TDO	10	GND
11	XJTAG_TRST_N	12	XSPI0_CLK
13	GND	14	XSPI0_MOSI
15	XEINT0	16	XSPI0_CS
17	XEINT2	18	XSPI0_MISO
19	XEINT1	20	GND
21	PWR_RST	22	XUART0_RXD
23	XI2C0_SCL	24	XUART0_TXD
25	XI2C0_SDA	26	GND
27	XI2C1_SCL	28	XPWM3_OUT
29	XI2C1_SDA	30	XPWM2_OUT
31	GND	32	XPWM5_OUT
33	XDEBUG_TXD	34	XPWM0_OUT
35	XDEBUG_RXD	36	XPWM1_OUT
37	Not Connected	38	XPWM4_OUT
39	Not Connected	40	Not Connected
41	Not Connected	42	GND
43	DC_5V_12V	44	GND
45	DC_5V_12V	46	GND
47	DC_5V_12V	48	GND
49	DC_5V_12V	50	GND

CON701 HEADER SIGNALS

The following signals as depicted in *Table 16* can be found on connector 701. This connector, together with CON702 connects the ARTIK 053 Module with the Interposer Board.

Table 16. CON701 signal description

Connector CON701 (CON400 on Interposer)			
Pin Name	Description	Pin Name	Description
1	XGPIO26	2	XSPI1_CSN
3	XGPIO25	4	XSPI1_MOSI
5	XGPIO24	6	XSPI1_CLK
7	XGPIO21	8	XSPI1_MISO
9	XGPIO19	10	GND
11	XGPIO18	12	Not Connected
13	XGPIO17	14	XGPIO3
15	XGPIO14	16	XGPIO1
17	XGPIO13	18	GND
19	XGPIO16	20	XGPIO5
21	XGPIO15	22	XGPIO4
23	XGPIO20	24	XGPIO2
25	GND	26	XGPIO7
27	XADC0AIN_0	28	XGPIO8
29	XADC0AIN_1	30	XGPIO6
31	XADC0AIN_2	32	GND
33	XADC0AIN_3	34	XGPIO11
35	GND	36	XGPIO9
37	XGPIO23	38	XGPIO10
39	XGPIO22	40	XGPIO12
41	Not Connected	42	GND
43	Not Connected	44	XUART3_TXD
45	GND	46	XUART3_RXD
47	GND	48	GND
49	GND	50	GND

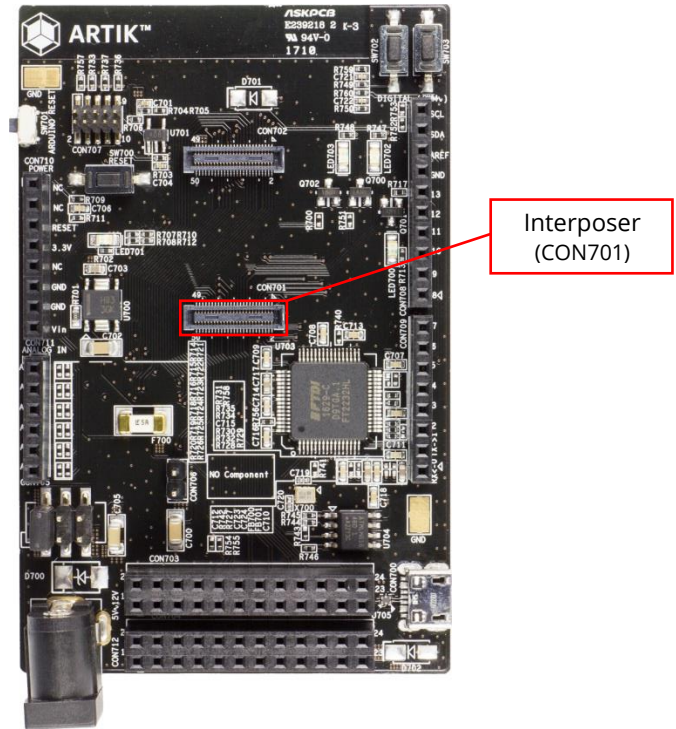

Figure 17. Interposer connector location

When mounting an ARTIK 053 Module on the Starter Board, make certain that you orient the ARTIK 053 Module such that the ARTIK 053 Module Antenna structure is closest to the Samsung “ARTIK™” logo located on the Starter Board. See *Figure 1* for details.

CON702 HEADER SIGNALS

The following signals as depicted in [Table 17](#) can be found on connector 702. This connector, together with CON701 connects the ARTIK 053 Module with the Interposer Board.

Table 17. CON702 signal description

Connector CON702 (CON401 on Interposer)			
Pin Name	Description	Pin Name	Description
1	XRESET_N	2	XUART2_TXD
3	XJTAG_TMS	4	XUART2_RXD
5	XJTAG_TDI	6	XUART1_RXD
7	XJTAG_TCK	8	XUART1_TXD
9	XJTAG_TDO	10	GND
11	XJTAG_TRST_N	12	XSPI0_CLK
13	GND	14	XSPI0_MOSI
15	XEINT0	16	XSPI0_CS
17	XEINT2	18	XSPI0_MISO
19	XEINT1	20	GND
21	PWR_RST	22	XUART0_RXD
23	XI2C0_SCL	24	XUART0_TXD
25	XI2C0_SDA	26	GND
27	XI2C1_SCL	28	XPWM3_OUT
29	XI2C1_SDA	30	XPWM2_OUT
31	GND	32	XPWM5_OUT
33	XDEBUG_TXD	34	XPWM0_OUT
35	XDEBUG_RXD	36	XPWM1_OUT
37	XADC4	38	XPWM4_OUT
39	XADC5	40	Not Connected
41	Not Connected	42	GND
43	DC_5V_12V	44	GND
45	DC_5V_12V	46	GND
47	DC_5V_12V	48	GND
49	DC_5V_12V	50	GND

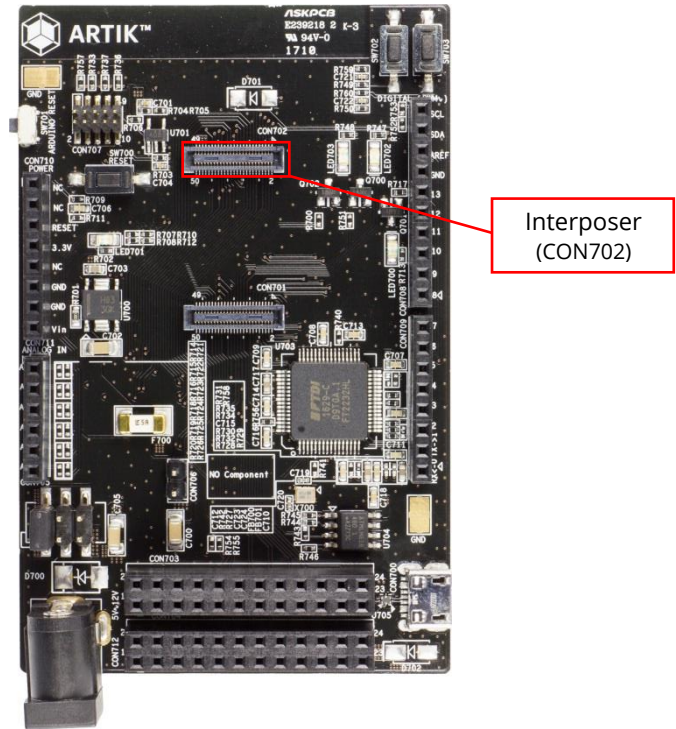

Figure 18. Interposer connector location

When mounting an ARTIK 053 Module on the Starter Board, make certain that you orient the ARTIK 053 Module such that the ARTIK 053 Module Antenna structure is closest to the Samsung “ARTIK™” logo located on the Starter Board. See [Figure 1](#) for details.

INTERPOSER BOARD MECHANICAL DIMENSIONS

Figure 19 shows the mechanical dimensions of the ARTIK 053 Interposer Board.

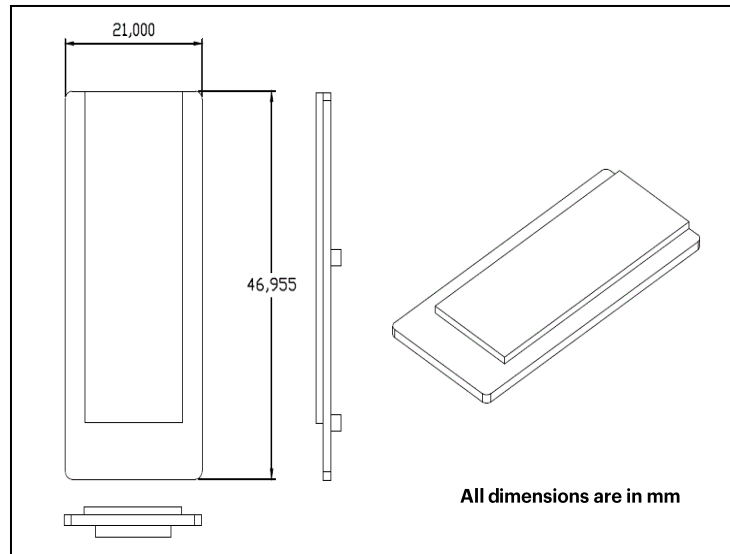

Figure 19. Mechanical Dimensions Interposer Board

HANDLING GUIDE

Precaution against Electrostatic Discharge

Ensure the ARTIK 053 Starter Kit is protected against static electricity.

Contamination

Do not expose the ARTIK 053 Starter Kit to dust, dirt, or adhesives.

Temperature/Humidity

The ARTIK 053 Starter Kit is sensitive to:

- Environment
- Temperature
- Humidity

High temperature or humidity deteriorates the characteristics of ARTIK 053 Starter Kit, avoid such conditions.

Mechanical Shock

Do not to apply excessive mechanical shock or force to the ARTIK 053 Starter Kit.

Chemical

Do not expose the ARTIK 053 Starter Kit to chemicals. Exposure to chemicals causes deterioration or corrosion of the ARTIK 053 Starter Kit.

EMS (Electro Magnetic Susceptibility)

Strong electromagnetic waves or magnetic fields may affect the characteristics of the ARTIK 053 Starter Kit.

LEGAL INFORMATION

INFORMATION IN THIS DOCUMENT IS PROVIDED IN CONNECTION WITH THE SAMSUNG ARTIK™ DEVELOPMENT KIT AND ALL RELATED PRODUCTS, UPDATES, AND DOCUMENTATION (HEREINAFTER “SAMSUNG PRODUCTS”). NO LICENSE, EXPRESS OR IMPLIED, BY ESTOPPEL OR OTHERWISE, TO ANY INTELLECTUAL PROPERTY RIGHTS IS GRANTED BY THIS DOCUMENT. THE LICENSE AND OTHER TERMS AND CONDITIONS RELATED TO YOUR USE OF THE SAMSUNG PRODUCTS ARE GOVERNED EXCLUSIVELY BY THE SAMSUNG ARTIK™ DEVELOPER LICENSE AGREEMENT THAT YOU AGREED TO WHEN YOU REGISTERED AS A DEVELOPER TO RECEIVE THE SAMSUNG PRODUCTS. EXCEPT AS PROVIDED IN THE SAMSUNG ARTIK™ DEVELOPER LICENSE AGREEMENT, SAMSUNG ELECTRONICS CO., LTD. AND ITS AFFILIATES (COLLECTIVELY, “SAMSUNG”) ASSUMES NO LIABILITY WHATSOEVER, INCLUDING WITHOUT LIMITATION CONSEQUENTIAL OR INCIDENTAL DAMAGES, AND SAMSUNG DISCLAIMS ANY EXPRESS OR IMPLIED WARRANTY, ARISING OUT OF OR RELATED TO YOUR SALE, APPLICATION AND/OR USE OF SAMSUNG PRODUCTS INCLUDING LIABILITY OR WARRANTIES RELATED TO FITNESS FOR A PARTICULAR PURPOSE, MERCHANTABILITY, OR INFRINGEMENT OF ANY PATENT, COPYRIGHT, OR OTHER INTELLECTUAL PROPERTY RIGHT.

SAMSUNG RESERVES THE RIGHT TO CHANGE PRODUCTS, INFORMATION, DOCUMENTATION AND SPECIFICATIONS WITHOUT NOTICE. THIS INCLUDES MAKING CHANGES TO THIS DOCUMENTATION AT ANY TIME WITHOUT PRIOR NOTICE. THIS DOCUMENTATION IS PROVIDED FOR REFERENCE PURPOSES ONLY, AND ALL INFORMATION DISCUSSED HEREIN IS PROVIDED ON AN “AS IS” BASIS, WITHOUT WARRANTIES OF ANY KIND. SAMSUNG ASSUMES NO RESPONSIBILITY FOR POSSIBLE ERRORS OR OMISSIONS, OR FOR ANY CONSEQUENCES FROM THE USE OF THE DOCUMENTATION CONTAINED HEREIN.

Samsung Products are not intended for use in medical, life support, critical care, safety equipment, or similar applications where product failure could result in loss of life or personal or physical harm, or any military or defense application, or any governmental procurement to which special terms or provisions may apply.

This document and all information discussed herein remain the sole and exclusive property of Samsung. All brand names, trademarks and registered trademarks belong to their respective owners. For updates or additional information about Samsung ARTIK™, contact the Samsung ARTIK™ team via the Samsung ARTIK™ website at www.artik.io.

Copyright © 2017 Samsung Electronics Co., Ltd.

All rights reserved. No part of this publication may be reproduced, stored in a retrieval system, or transmitted in any form or by any means, electric or mechanical, by photocopying, recording, or otherwise, without the prior written consent of Samsung Electronics.

SAMSUNG ELECTRONICS RESERVES THE RIGHT TO CHANGE PRODUCTS, INFORMATION AND SPECIFICATIONS WITHOUT NOTICE. Products and specifications discussed herein are for reference purposes only. All information discussed herein is provided on an "AS IS" basis, without warranties of any kind. This document and all information discussed herein remain the sole and exclusive property of Samsung Electronics. No license of any patent, copyright, mask work, trademark or any other intellectual property right is granted by one party to the other party under this document, by implication, estoppel or other-wise. Samsung products are not intended for use in life support, critical care, medical, safety equipment, or similar applications where product failure could result in loss of life or personal or physical harm, or any military or defense application, or any governmental procurement to which special terms or provisions may apply. For updates or additional information about Samsung products, contact your nearest Samsung office. All brand names, trademarks and registered trademarks belong to their respective owners.

X-ON Electronics

Largest Supplier of Electrical and Electronic Components

Click to view similar products for [Development Boards & Kits - ARM category](#):

Click to view products by [Seeed Studio manufacturer](#):

Other Similar products are found below :

[SAFETI-HSK-RM48](#) [PICOHOBBITFL](#) [CC-ACC-MMK-2443](#) [TWR-MC-FRDMKE02Z](#) [EVALSPEAR320CPU](#) [EVB-SCMIMX6SX](#)
[MAX32600-KIT#](#) [TMDX570LS04HDK](#) [TXSD-SV70](#) [OM13080UL](#) [EVAL-ADUC7120QSPZ](#) [OM13082UL](#) [TXSD-SV71](#)
[YGRPEACHNORMAL](#) [OM13076UL](#) [PICODWARFFL](#) [YR8A77450HA02BG](#) [3580](#) [32F3348DISCOVERY](#) [ATTINY1607](#) [CURIOSITY](#)
[NANO](#) [PIC16F15376](#) [CURIOSITY NANO BOARD](#) [PIC18F47Q10](#) [CURIOSITY NANO](#) [VISIONSTK-6ULL V.2.0](#) [80-001428](#) [DEV-17717](#)
[EAK00360](#) [YR0K77210B000BE](#) [RTK7EKA2L1S00001BE](#) [MAX32651-EVKIT#](#) [SLN-VIZN-IOT](#) [LV18F V6 DEVELOPMENT SYSTEM](#)
[READY FOR AVR BOARD](#) [READY FOR PIC BOARD](#) [READY FOR PIC \(DIP28\)](#) [EVB-VF522R3](#) [AVRPLC16 V6 PLC SYSTEM](#)
[MIKROLAB FOR AVR XL](#) [MIKROLAB FOR PIC L](#) [MINI-AT BOARD - 5V](#) [MINI-M4 FOR STELLARIS](#) [MOD-09.Z](#) [BUGGY +](#)
[CLICKER 2 FOR PIC32MX + BLUETOOT](#) [1410](#) [LETS MAKE PROJECT PROGRAM. RELAY PIC](#) [LETS MAKE - VOICE](#)
[CONTROLLED LIGHTS](#) [LPC-H2294](#) [DSPIC-READY2 BOARD](#) [DSPIC-READY3 BOARD](#) [MIKROBOARD FOR ARM 64-PIN](#)
[MIKROLAB FOR AVR](#)