

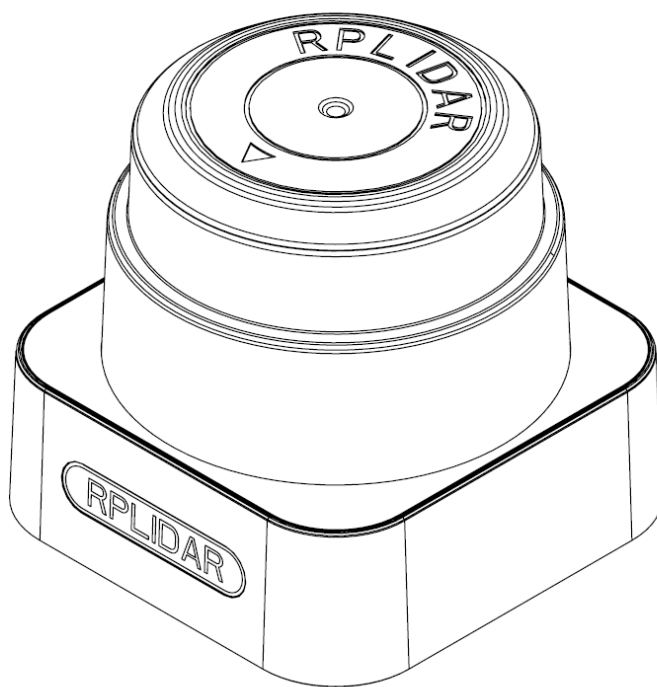
# RPLIDAR S1

Low Cost 360 Degree Laser Range Scanner

## Introduction and Datasheet

Model: S1

9.2K



<b>CONTENTS</b> .....	<b>1</b>
<b>INTRODUCTION</b> .....	<b>3</b>
SYSTEM CONNECTION .....	4
MECHANISM.....	4
SAFETY AND SCOPE .....	6
DATA OUTPUT.....	6
HIGH SPEED SAMPLING PROTOCOL AND COMPATIBILITY .....	7
APPLICATION SCENARIOS.....	7
<b>SPECIFICATION</b> .....	<b>8</b>
MEASUREMENT PERFORMANCE .....	8
LASER POWER SPECIFICATION.....	8
OPTICAL WINDOW.....	8
COORDINATE SYSTEM DEFINITION OF SCANNING DATA .....	9
COMMUNICATION INTERFACE .....	10
MISC.....	12
<b>SELF-PROTECTION AND STATUS DETECTION</b> .....	<b>13</b>
<b>SDK AND SUPPORT</b> .....	<b>14</b>
<b>MECHANICAL DIMENSIONS</b> .....	<b>15</b>
<b>REVISION HISTORY</b> .....	<b>16</b>
<b>APPENDIX</b> .....	<b>17</b>
IMAGE AND TABLE INDEX .....	17



The RPLIDAR S1 is the next generation low cost 360 degree 2D laser scanner (LIDAR) solution developed by SLAMTEC. It can take up to 9200 samples of laser ranging per second with high rotation speed. And equipped with SLAMTEC patented OPTMAG technology, it breakouts the life limitation of traditional LIDAR system so as to work stably for a long time.

The system can perform 2D 360-degree scan within a 40-meter range. The generated 2D point cloud data can be used in mapping, localization and object/environment modeling.

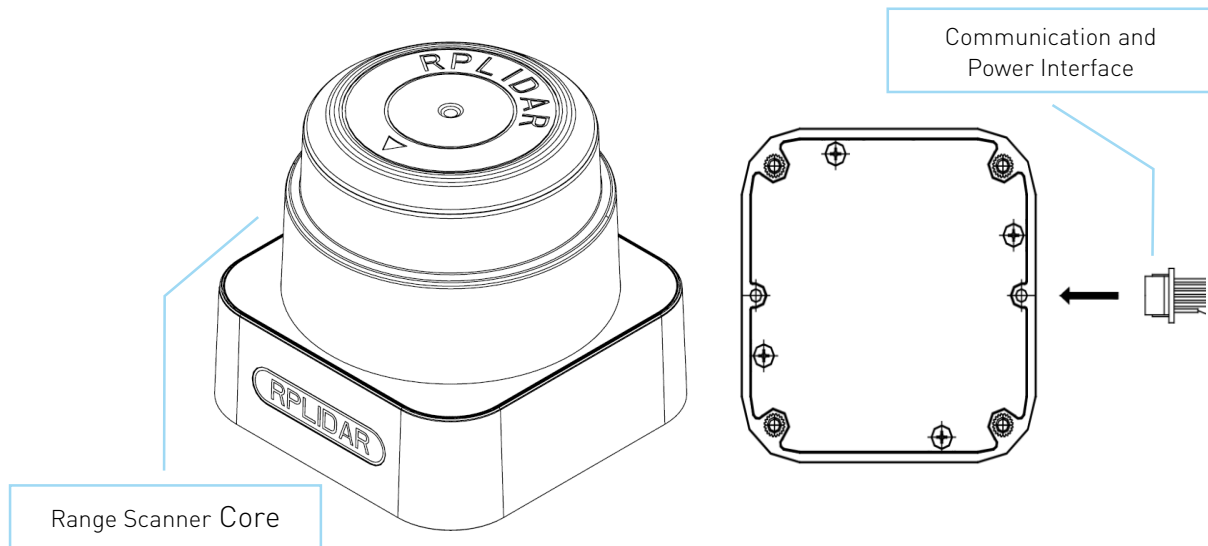
Compared with RPLIDARs in other series, RPLIDAR S1 has a more stable performance when detecting objects in long distance, objects in white or black alternatively and objects under direct sunlight, which is ideal for map building in the outdoor environment within a 40-meter ranging radius. Therefore, it can be widely applied in many consumer-oriented business scenarios.

The typical scanning frequency of RPLIDAR S1 is 10Hz(600rpm), and the frequency can be freely adjusted within the 8-15Hz range according to the specific requirements. With the 10Hz scanning frequency, the sampling rate is 9.2kHz and the angular resolution is 0.391°.

Due to the improvements in SLAMTEC hardware operating performance and related algorithm, RPLIDAR S1 works well in all kinds of indoor environment and outdoor environment with direct sunlight. Meanwhile, before leaving the factory, every RPLIDAR S1 has passed the strict testing to ensure the laser output power meet the eye-safety standard of IEC-60825 Class 1.

## System connection

The RPLIDAR S1 consists of a range scanner core and the mechanical powering part which makes the core rotate at a high speed. When it functions normally, the scanner will rotate and scan clockwise. And users can get the range scan data via the communication interface of the RPLIDAR and control the start, stop and rotating speed of the rotate motor via PWM.



*Figure 1-1 RPLIDAR S1 System Composition*

The RPLIDAR S1 comes with a rotation speed detection and adaptive system. The system will adjust the angular resolution automatically according to the actual rotating speed. And there is no need to provide complicated power system for RPLIDAR S1. In this way, the simple power supply schema saves the BOM cost. If the actual speed of the RPLIDAR is required, the host system can get the related data via communication interface.

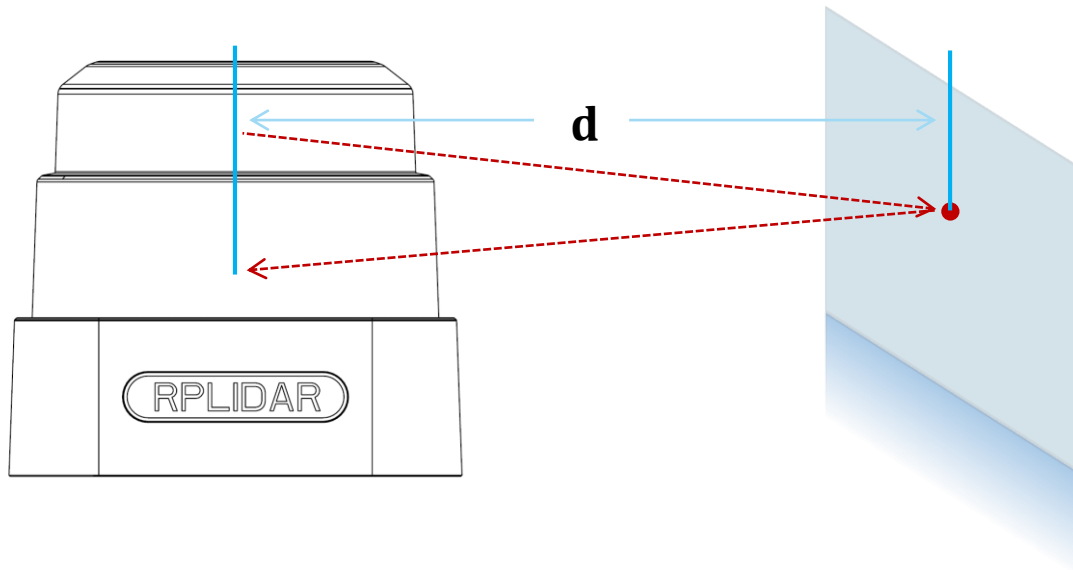
The detailed specification about power and communication interface can be found in the following sections.

## Mechanism

The RPLIDAR S1 is based on laser flight-of-time (TOF) ranging principle and adopts the high-speed laser acquisition and processing hardware developed by SLAMTEC. The system ranges more than 9200 times per second.

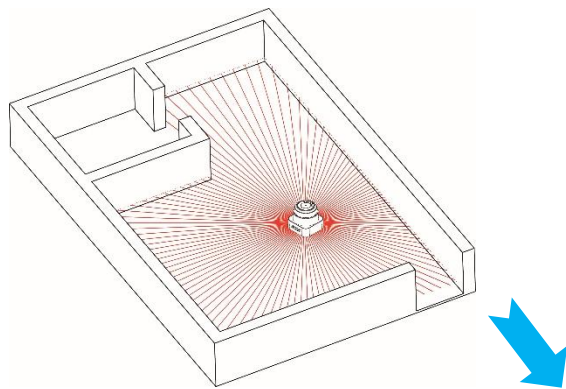
During every ranging process, the RPLIDAR emits modulated infrared laser signal and the laser signal is then reflected by the object to be detected. The returning signal is then sampled by laser acquisition system in RPLIDAR and the DSP

embedded in RPLIDAR starts processing the sample data and outputs distance value and angle value between object and RPLIDAR S1 via communication interface.

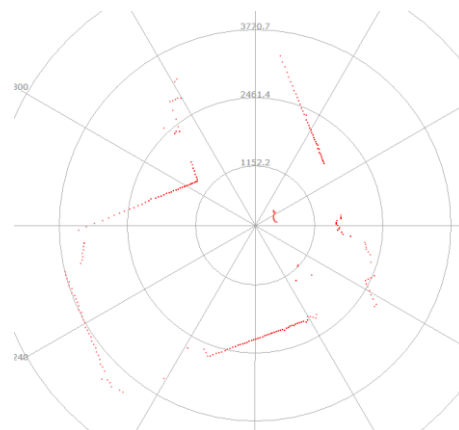


*Figure 1-2 The RPLIDAR S1 Working Schematic*

When drove by the motor system, the range scanner core will rotate clockwise and perform the 360-degree scan for the current environment.



\*Note: The LIDAR scan image is not directly relative to the environment showed here. Illustrative purpose only.



*Figure 1-3 The Obtained Environment Map from RPLIDAR S1 Scanning*

Class I

## Safety and Scope

The RPLIDAR S1 system uses a low power infrared laser as its light source, and drives it by using modulated pulse. The laser emits light in a very short time frame which can ensure its safety to human and pet, and it reaches Class I laser safety standard. Complies with 21 CFR 1040.10 and 1040.11 except for deviations pursuant to Laser Notice No. 50, dated June 24, 2007.

**Caution:** Use of controls or adjustments or performance of procedures other than those specified herein may result in hazardous radiation exposure.

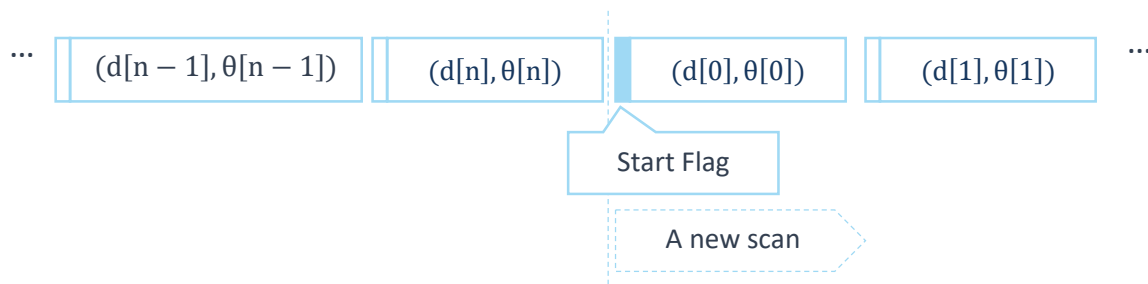
The modulated laser can effectively avoid the interference from ambient light and sunlight during ranging scanning process, which makes RPLIDAR S1 work excellent in all kinds of indoor environment and outdoor environment without sunlight.

## Data Output

During the working process, the RPLIDAR will output the sampling data via the communication interface. And each sample point data contains the information in the following table. If you need detailed data format and communication protocol, please contact SLAMTEC.

Data Type	Unit	Description
Distance	mm	Current measured distance value between the rotating core of the RPLIDAR and the sampling point
Heading	degree	Current heading angle of the measurement
Start Flag	(Bool)	Flag of a new scan
Checksum		The Checksum of RPLIDAR return data

*Figure 1-4 The RPLIDAR S1 Sample Point Data Information*



*Figure 1-5 The RPLIDAR S1 Sample Point Data Frames*

The RPLIDAR S1 outputs sampling data continuously and it contains the sample point data frames in the above figure. Host systems can configure output format and stop RPLIDAR by sending stop command. For detailed operations please contact SLAMTEC.

## High Speed Sampling Protocol and Compatibility

The RPLIDAR S1 adopts the newly extended high Speed sampling protocol for outputting the 9200 times per second laser range scan data. Users are required to update the matched SDK or modify the original driver and use the new protocol for the 9200 times per second mode of RPLIDAR S1. Please check the related protocol documents for details.

## Application Scenarios

The RPLIDAR can be used in the following application scenarios:

- General robot navigation and localization
- Environment scanning and 3D re-modeling
- Service robot or industrial robot working for long hours
- Home service /cleaning robot navigation and localization
- General simultaneous localization and mapping (SLAM)
- Smart toy's localization and obstacle avoidance

## Measurement Performance

### ● For Model S1 Only

Item	Detail
Application Scenarios	Ideal for both outdoor and indoor environments with reliable resistance to daylight.
Distance Range	White object: 40 meters Black object: 10 meters
Sample Rate	9.2kHz
Scan Rate	Typical value: 10 Hz (adjustable between 8 Hz-15 Hz)
Angular Resolution	Typical value: 0.391 °(0.313 °-0.587 ° depends on Scan Rate)
Communication Interface	TTL UART
Communication Speed	256000 bps
Accuracy	±5cm
Resolution	3cm

*Figure 2-1 RPLIDAR S1 Performance*

Note: \* means the accuracy of the full range under white diffuse surface.

## Laser Power Specification

### ● For Model S1 Only

Item	Unit	Min	Typical	Max	Comments
Laser wavelength	Nanometer(nm)	895	905	915	Infrared Light Band
Laser power	Milliwatt (W)	-	28	-	Peak power
Pulse length	Microsecond(ns)	-	10	-	-
Laser Safety Class	-	-	IEC-60825 Class 1	-	-

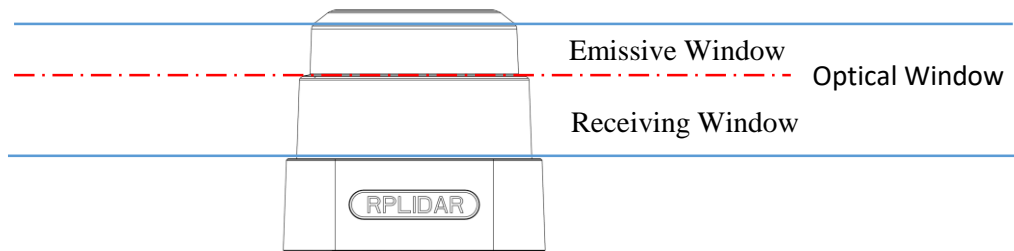
*Figure 2-2 RPLIDAR S1 Optical Specification*

## Optical Window

To make the RPLIDAR S1 working normally, please ensure proper space to be left for its emitting and receiving laser lights when designing the host system. The obscuring of the host system for the ranging window will impact the performance and resolution of RPLIDAR S1. If you need cover the RPLIDAR S1 with translucent



materials or have other special needs, please contact SLAMTEC about the feasibility.

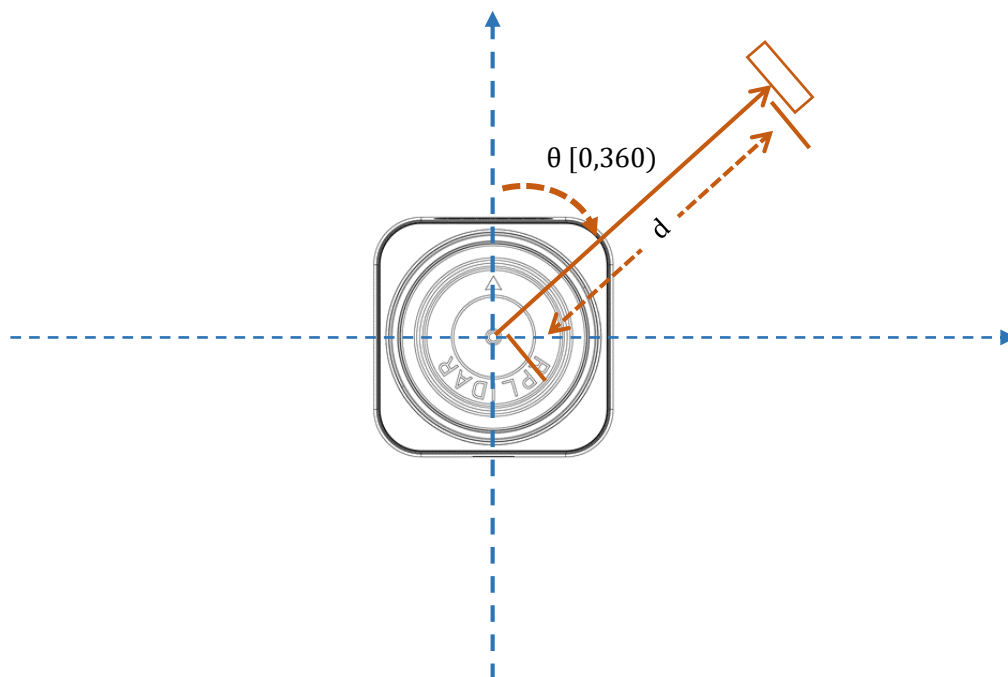


*Figure 2-3 RPLIDAR S1 Optical Window*

You can check the Mechanical Dimensions chapter for detailed window dimensions.

## Coordinate System Definition of Scanning Data

The RPLIDAR S1 adopts coordinate system of the left hand. The dead ahead of the sensors is the x axis of the coordinate system; the origin is the rotating center of the range scanner core. The rotation angle increases as rotating clockwise. The detailed definition is shown in the following figure:



*Figure 2-4 RPLIDAR S1 Scanning Data Coordinate System Definition*

## Communication interface

The RPLIDAR S1 uses separate 5V DC power for powering the range scanner core and the motor system. And the standard RPLIDAR S1 uses SH1.0-6P female receptacle and interface lead as communication interface. Detailed interface definition is shown in the following figure:

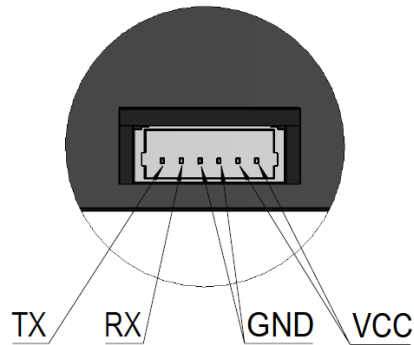


Figure 2-5 RPLIDAR S1 Female Receptacle Definition



Figure 2-6 RPLIDAR S1 Interface Lead Schematic Diagram

Color	Signal Name	Type	Description	Min	Typical	Max
Brown	VCC	Power	Total Power	4.8V	5V	5.5V
Purple						
Orange	GND	Power	GND	0V	0V	0V
Yellow						
Green	RX	Input	Serial port input of the scanner core	0V	3.3V	3.5V
Blue	TX	Output	Serial port output of the scanner core	0V	3.3V	3.5V

Figure 2-7 RPLIDAR S1 External Interface Signal Definition

## Power Supply Interface

RPLIDAR S1 takes the only external power to power the range scanner core and the motor system which make the core rotate. To make the RPLIDAR S1 work normally, the host system needs to ensure the output of the power and meet its requirements of the power supply ripple.

### ● For Model S1 Only

Item	Unit	Min	Typical	Max	Remark
Power Voltage	V	4.8	5	5.5	If the voltage exceeds the max value, it may damage the core
Power Ripple	Voltage mV	-	20	50	High ripple may cause the core working failure.
System Current	Start mA	-	1400	1500	The system startup requires relatively higher current.
Power Current	mA	TBD	40	50	5V Power, power off
		TBD	350	500	5V Power, power on

Figure 2-8 RPLIDAR S1 Power Supply Specification

## Data communication interface

The RPLIDAR S1 takes the 3.3V-TTL serial port (UART) as the communication interface. The table below shows the transmission speed and the protocol standard.

Item	Unit	Min	Typical	Max	Comments
Band rate	bps	-	256000	-	-
Working mode	-	-	8N1	-	8n1
Output high voltage	Volt (V)	2.9	-	3.5	Logic High
Output low voltage	Volt (V)	-	-	0.4	Logic Low

Input high voltage	Volt (V)	1.6*	-	3.5	Logic High
Input low voltage	Volt (V)	-0.3	-	0.4	Logic Low

*Figure 2-9 RPLIDAR S1 Serial Port Interface Specifications*

Note: the RX input signal of S1 is current control type. In order to ensure the reliable signal identification inside the system, the actual control node voltage of this pin will not be lower than 1.6v.

## Scanner Motor Control

The RPLIDAR S1 is embedded with a closed motor control system which realize accurate rotating speed control. Users can control the start, the stop and the rotating rate by sending protocol commands to RPLIDAR. However, the motor can't start and stop alone, its working state depends on the laser scan operation.

## MISC

### ● For Model S1 Only

Item	Unit	Min	Typical	Max	Comments
Weight	Gram (g)	TBD	105	TBD	
Working range	temperature	Degree Celsius (°C)	-10	25	50
Storage range	temperature	Degree Celsius (°C)	TBD	TBD	TBD

*Figure 2-10 RPLIDAR S1 MISC Specification*

To ensure the laser of RPLIDAR always working in the safety range and avoid any other damage caused by device, the RPLIDAR comes with laser power detection and sensor healthy check feature. It will shut down the laser and stop working automatically when any of the following errors has been detected.

- Scan speed of Laser scanner system is unstable
- Scan speed of Laser scanner system is too slow
- Laser signal sensor works abnormally

The host systems can check the status of the RPLIDAR S1 via the communication interface and restart the RPLIDAR S1 to try to recover work from error.

To facilitate the usage of RPLIDAR S1 in the product development and speed up the development cycle for users, SLAMTEC has provided the **Framegrabber** plugin in RoboStudio for testing and debugging as well as the SDK available under Windows, x86 Linux and Arm Linux. Please contact SLAMTEC for detail information.

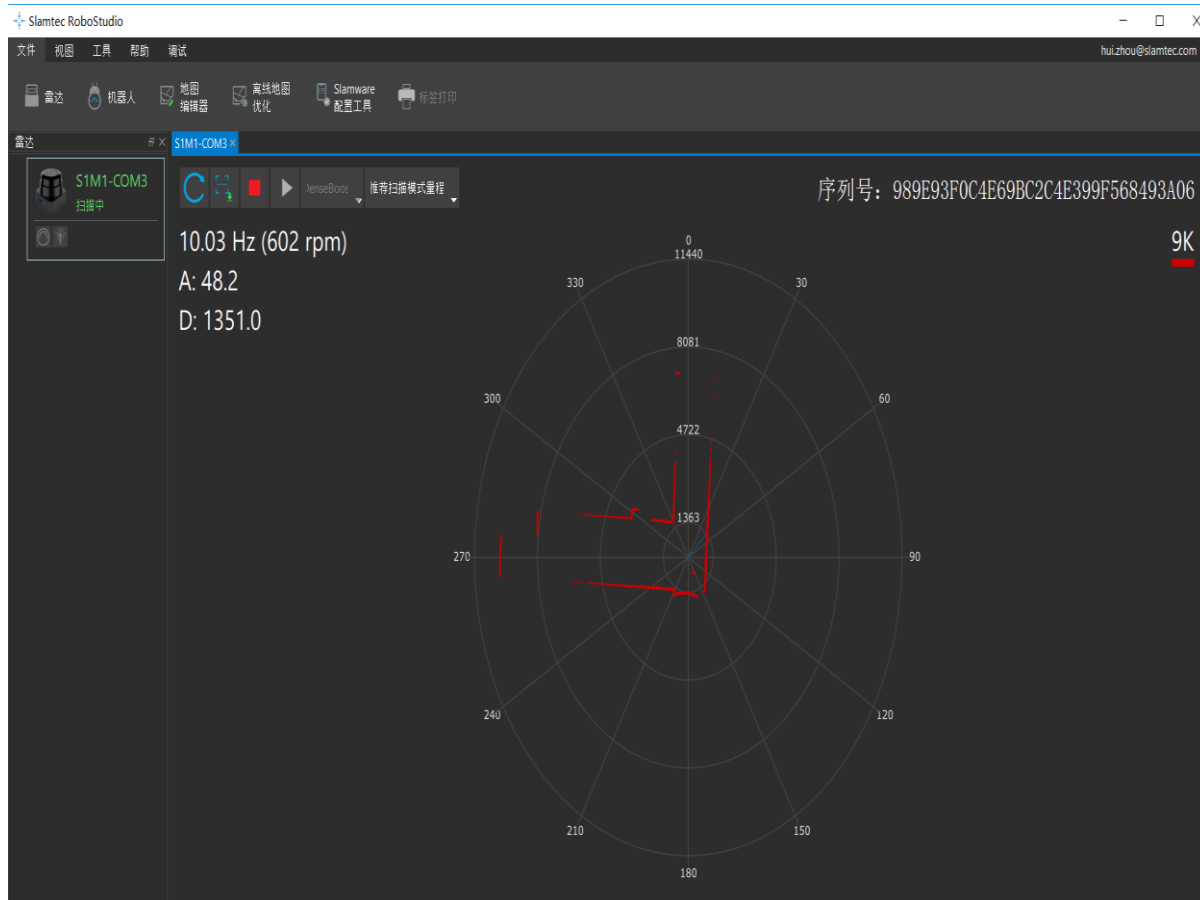


Figure 4-1 the Framegrabber Plugin in RoboStudio

The mechanical dimensions of the RPLIDAR S1 are shown as below:

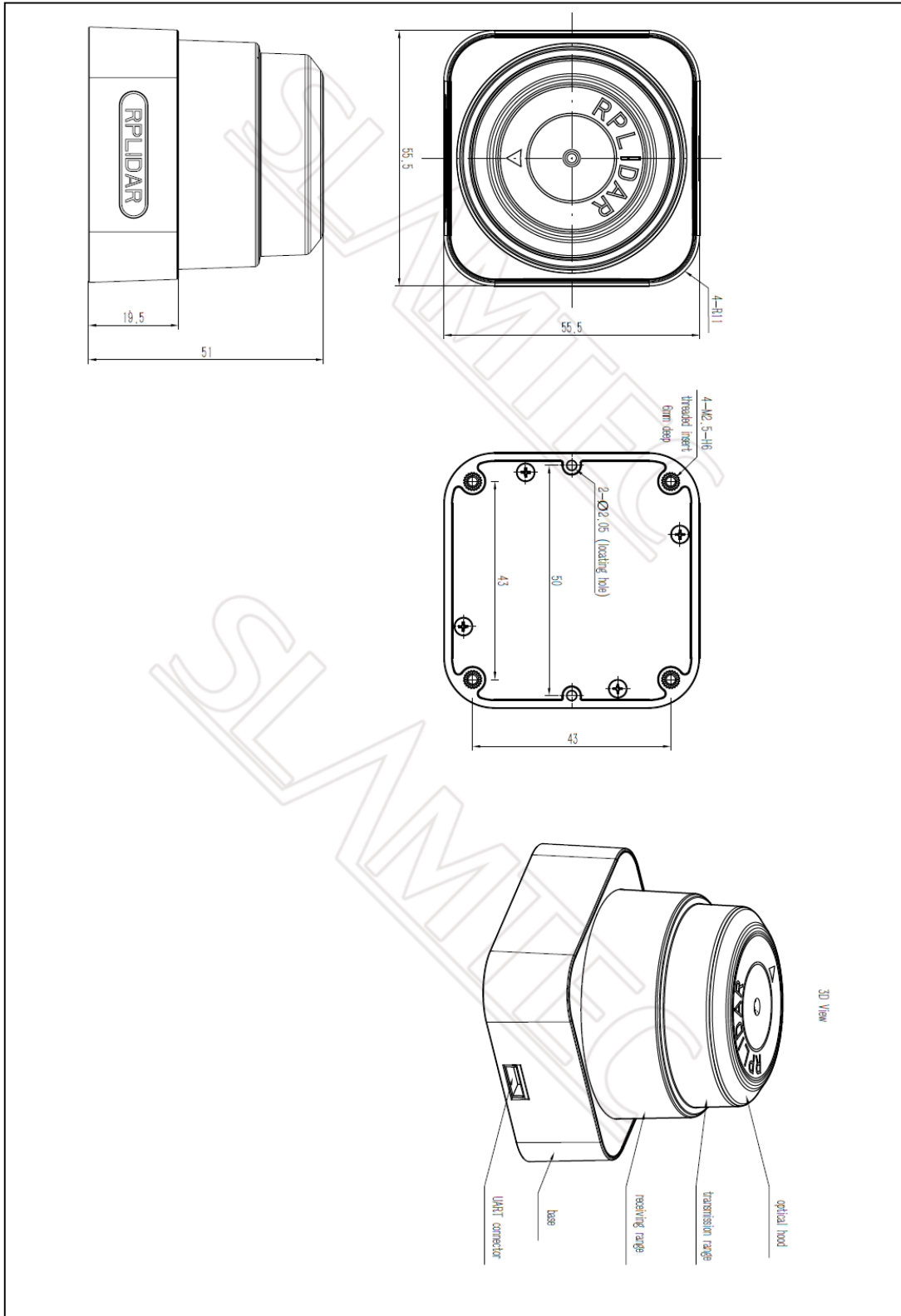


Figure 5-1 RPLIDAR S1 Mechanical Dimensions

Note: the 4 M2.5 screws in the bottom should be no longer than 4mm, or the internal module would be damaged.

Date	Version	Description
2019-3-7	1.0	Initial version for S1



## Image and Table Index

FIGURE 1-1 RPLIDAR S1 SYSTEM COMPOSITION.....	4
FIGURE 1-2 THE RPLIDAR S1 WORKING SCHEMATIC .....	5
FIGURE 1-3 THE OBTAINED ENVIRONMENT MAP FROM RPLIDAR S1 SCANNING .....	6
FIGURE 1-4 THE RPLIDAR S1 SAMPLE POINT DATA INFORMATION.....	6
FIGURE 1-5 THE RPLIDAR S1 SAMPLE POINT DATA FRAMES.....	7
FIGURE 2-1 RPLIDAR S1 PERFORMANCE.....	8
FIGURE 2-2 RPLIDAR S1 OPTICAL SPECIFICATION .....	8
FIGURE 2-3 RPLIDAR S1 OPTICAL WINDOW .....	9
FIGURE 2-4 RPLIDAR S1 SCANNING DATA COORDINATE SYSTEM DEFINITION.....	9
FIGURE 2-5 RPLIDAR S1 FEMALE RECEPTACLE DEFINITION .....	10
FIGURE 2-6 RPLIDAR S1 INTERFACE LEAD SCHEMATIC DIAGRAM.....	10
FIGURE 2-7 RPLIDAR S1 EXTERNAL INTERFACE SIGNAL DEFINITION.....	11
FIGURE 2-8 RPLIDAR S1 POWER SUPPLY SPECIFICATION .....	11
FIGURE 2-9 RPLIDAR S1 SERIAL PORT INTERFACE SPECIFICATIONS .....	12
FIGURE 2-10 RPLIDAR S1 MISC SPECIFICATION.....	12
FIGURE 4-1 THE FRAMEGRABBER PLUGIN IN ROBOSTUDIO.....	14
FIGURE 5-1 RPLIDAR S1 MECHANICAL DIMENSIONS.....	15

Manufacturer: SHANGHAI SLAMTEC CO., LTD.

Address: D-501 Shengyin Tower, 666 Shengxia Rd., Shanghai, China

Made in China

## X-ON Electronics

Largest Supplier of Electrical and Electronic Components

*Click to view similar products for [Development Boards & Kits - ARM category](#):*

*Click to view products by [Seeed Studio manufacturer](#):*

Other Similar products are found below :

[SAFETI-HSK-RM48](#) [PICOHOBBITFL](#) [CC-ACC-MMK-2443](#) [TWR-MC-FRDMKE02Z](#) [EVALSPEAR320CPU](#) [EVB-SCMIMX6SX](#)  
[MAX32600-KIT#](#) [TMDX570LS04HDK](#) [TXSD-SV70](#) [OM13080UL](#) [EVAL-ADUC7120QSPZ](#) [OM13082UL](#) [TXSD-SV71](#)  
[YGRPEACHNORMAL](#) [OM13076UL](#) [PICODWARFFL](#) [YR8A77450HA02BG](#) [3580](#) [32F3348DISCOVERY](#) [ATTINY1607](#) [CURIOSITY](#)  
[NANO](#) [PIC16F15376](#) [CURIOSITY NANO BOARD](#) [PIC18F47Q10](#) [CURIOSITY NANO](#) [VISIONSTK-6ULL V.2.0](#) [80-001428](#) [DEV-17717](#)  
[EAK00360](#) [YR0K77210B000BE](#) [RTK7EKA2L1S00001BE](#) [MAX32651-EVKIT#](#) [SLN-VIZN-IOT](#) [LV18F V6 DEVELOPMENT SYSTEM](#)  
[READY FOR AVR BOARD](#) [READY FOR PIC BOARD](#) [READY FOR PIC \(DIP28\)](#) [EVB-VF522R3](#) [AVRPLC16 V6 PLC SYSTEM](#)  
[MIKROLAB FOR AVR XL](#) [MIKROLAB FOR PIC L](#) [MINI-AT BOARD - 5V](#) [MINI-M4 FOR STELLARIS](#) [MOD-09.Z](#) [BUGGY +](#)  
[CLICKER 2 FOR PIC32MX + BLUETOOT](#) [1410](#) [LETS MAKE PROJECT PROGRAM. RELAY PIC](#) [LETS MAKE - VOICE](#)  
[CONTROLLED LIGHTS](#) [LPC-H2294](#) [DSPIC-READY2 BOARD](#) [DSPIC-READY3 BOARD](#) [MIKROBOARD FOR ARM 64-PIN](#)  
[MIKROLAB FOR AVR](#)