

FRDM-KL25Z User's Manual

2012-09-24

Rev. 1.0

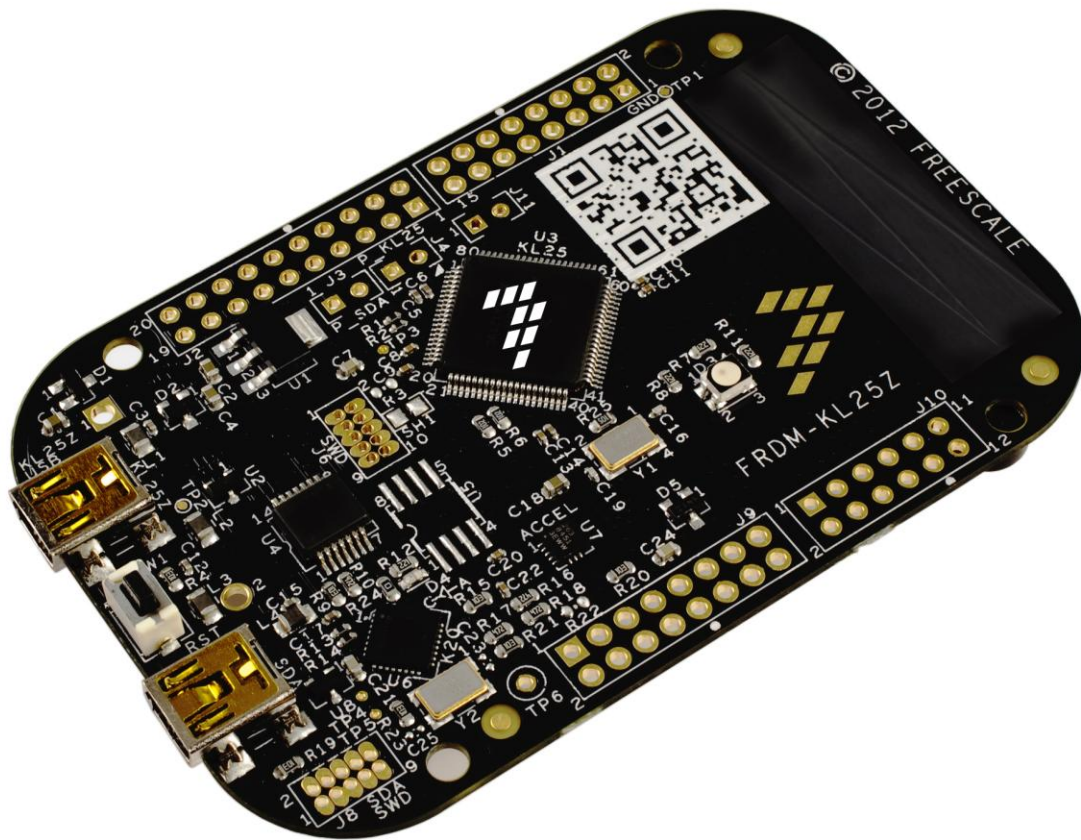

Table of Contents

1 Overview	3
2 Reference Documents	3
3 Getting Started	3
4 FRDM-KL25Z Hardware Overview	4
5 FRDM-KL25Z Hardware Description	5
5.1 Power Supply.....	5
5.2 Serial and Debug Adapter (OpenSDA)	7
5.2.1 Debug Interface.....	7
5.2.2 Virtual Serial Port.....	8
5.3 KL25Z Microcontroller	8
5.3.1 Clock Source	9
5.3.2 USB Interface.....	9
5.3.3 Serial Port	9
5.3.4 Reset.....	9
5.3.5 Debug.....	10
5.4 Capacitive Touch Slider.....	10
5.5 3-axis Accelerometer.....	10
5.6 RGB LED.....	10
5.7 Input/Output Connectors.....	11
5.8 Arduino Compatibility	12

1 Overview

The Freescale Freedom development platform is a set of software and hardware tools for evaluation and development. It is ideal for rapid prototyping of microcontroller-based applications. The Freescale Freedom KL25Z hardware, FRDM-KL25Z, is a simple, yet sophisticated design featuring a Kinetis L series microcontroller, the industry's first microcontroller built on the ARM® Cortex™-M0+ core.

FRDM-KL25Z can be used to evaluate the KL1 and KL2 Kinetis L series devices. It features a KL25Z128VLK, a KL2 family device boasting a max operating frequency of 48MHz, 128KB of flash, a full-speed USB controller, and loads of analog and digital peripherals. The FRDM-KL25Z hardware is form-factor compatible with the Arduino™ R3 pin layout, providing a broad range of expansion board options. The on-board interfaces include an RGB LED, a 3-axis digital accelerometer, and a capacitive touch slider.

The FRDM-KL25Z is the first hardware platform to feature the Freescale open standard embedded serial and debug adapter known as OpenSDA. This circuit offers several options for serial communications, flash programming and run-control debugging.

2 Reference Documents

The table below provides a list of reference documents for the FRDM-KL25Z hardware. All of these documents are available online at www.freescale.com/FRDM-KL25Z.

Table 1. FRDM-KL25Z Reference Documents

Filename	Description
<i>FRDM-KL25Z Quick Start Package</i>	Quick Start Guide and supporting files for getting started with the FRDM-KL25Z.
<i>FRDM-KL25Z User's Manual</i>	This document—overview and detailed information for the FRDM-KL25Z hardware.
<i>FRDM-KL25Z Pinouts</i>	Spreadsheet of pin connections for all MCU pins. Includes pinout for the I/O headers, Arduino R3 compatibility chart, and OpenSDA MCU pinout.
<i>FRDM-KL25Z Schematics</i>	PDF schematics for the FRDM-KL25Z hardware
<i>FRDM-KL25Z Design Package</i>	Zip file containing all design source files for the FRDM-KL25Z hardware
<i>OpenSDA User's Guide</i>	Overview and instructions for use of the OpenSDA embedded debug circuit

3 Getting Started

Refer to the *FRDM-KL25Z Quick Start Package* for step-by-step instructions for getting started with the FRDM-KL25Z. See the **Jump Start Your Design** section on www.freescale.com/FRDM-KL25Z for the Quick Start Package and software lab guides.

4 FRDM-KL25Z Hardware Overview

The features of the FRDM-KL25Z include:

- MKL25Z128VLK4 in an 80 LQFP package
- Capacitive touch slider
- MMA8451Q accelerometer
- Tri-color (RGB) LED
- Flexible power supply options – USB, coin cell battery, external source
- Battery-ready, power-measurement access points
- Easy access to MCU I/O via Arduino™ R3 compatible I/O connectors
- Programmable OpenSDA debug interface with multiple applications available including:
 - Mass storage device flash programming interface
 - P&E Debug interface provides run-control debugging and compatibility with IDE tools
 - CMSIS-DAP interface: new ARM standard for embedded debug interface
 - Data logging application

Figure 1 shows a block diagram of the FRDM-KL25Z design. The primary components and their placement on the hardware assembly are pointed out in Figure 2.

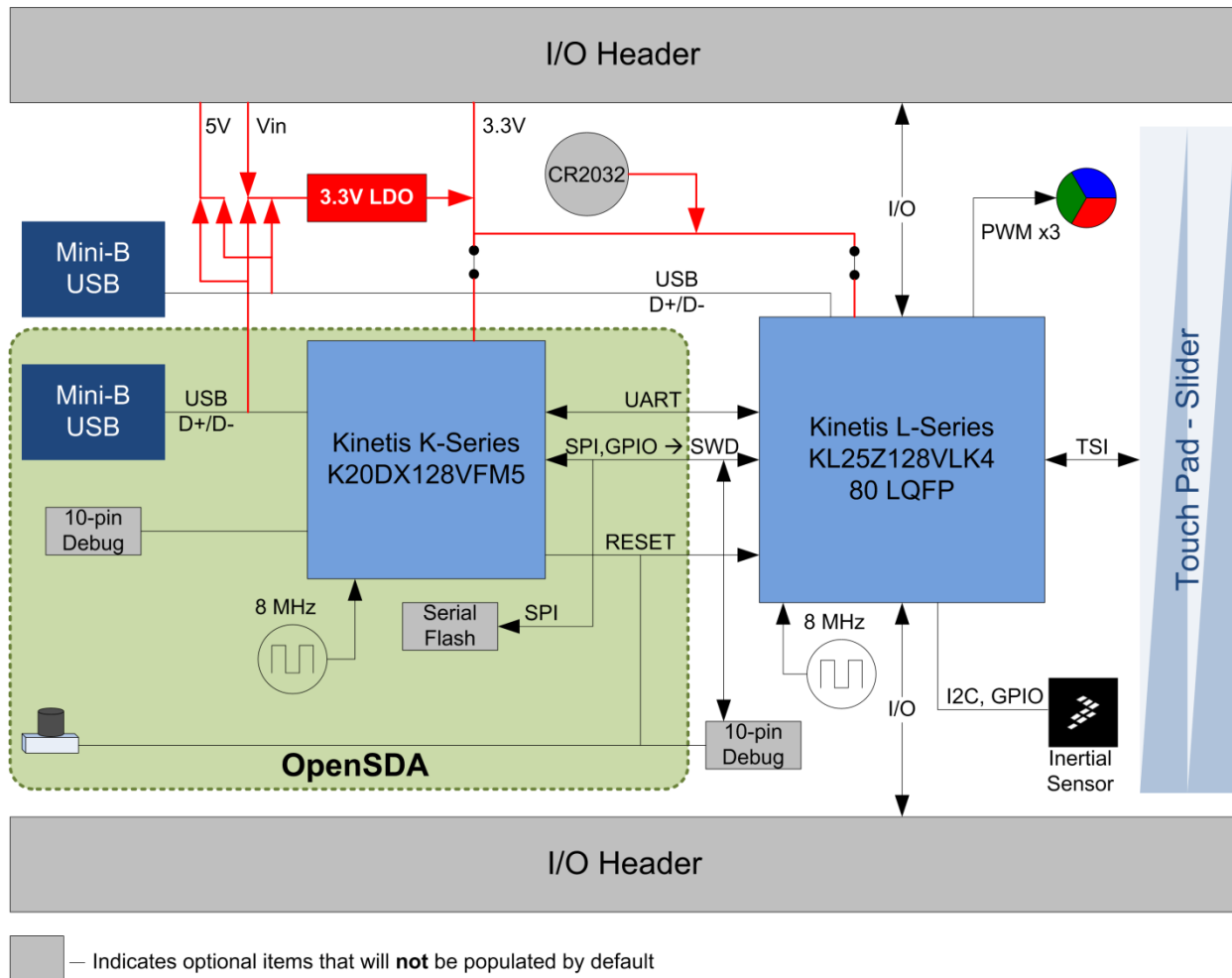

Figure 1. FRDM-KL25Z Block Diagram

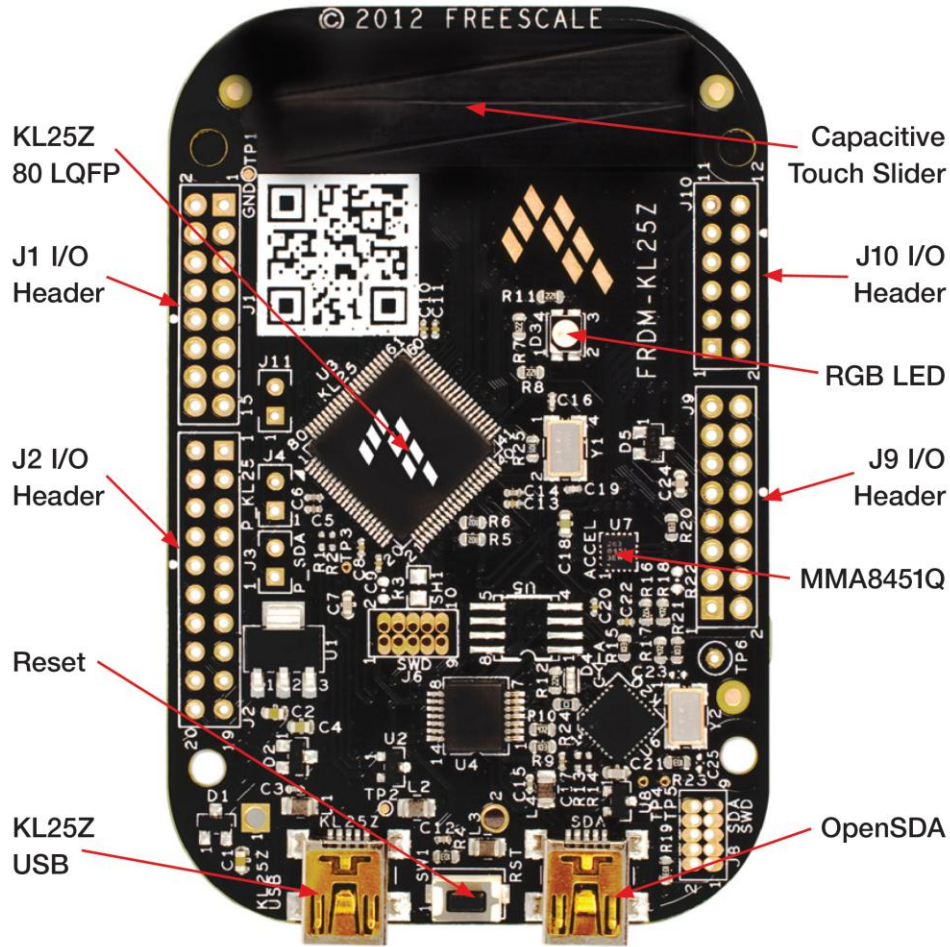

Figure 2. FRDM-KL25Z Feature Call-outs

5 FRDM-KL25Z Hardware Description

5.1 Power Supply

There are multiple power supply options on the FRDM-KL25Z. It can be powered from either of the USB connectors, the V_{IN} pin on the I/O header, an on-board coin cell battery, or an off-board 1.71-3.6V supply from the 3.3V pin on the I/O header. The USB and V_{IN} supplies are regulated on-board using a 3.3V linear regulator to produce the main power supply. The other two sources are not regulated on-board. Table 2 provides the operational details and requirements for the power supplies.

Table 2. Power Supply Requirements

Supply Source	Valid Range	OpenSDA Operational?	Regulated on-board?
OpenSDA USB (J7)	5V	Yes	Yes
KL25Z USB (J5)	5V	No	Yes
V_{IN} Pin	4.3-9V	No	Yes
3.3V Pin	1.71-3.6V	No	No
Coin Cell Battery	1.71-3.6V	No	No

Note that the OpenSDA circuit is only operational when a USB cable is connected and supplying power to J7. However, protection circuitry is in place to allow multiple sources to be powered at once.

Figure 3 shows the schematic drawing for the power supply inputs and the on-board voltage regulator.

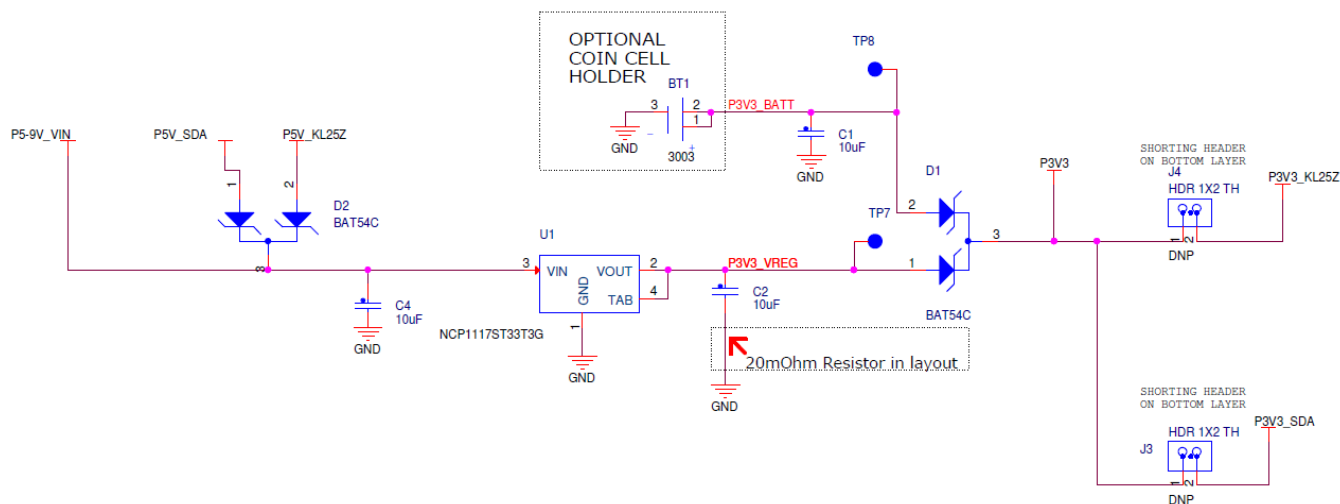

Figure 3. Power Supply Schematic

Table 3. FRDM-KL25Z Power Supplies

Power Supply Name	Description
P5-9V_VIN	Power supplied from the V_{IN} pin of the I/O headers (J9 pin 16).
P5V_SDA	Power supplied from the OpenSDA USB connector (J7). A Schottky diode provides back drive protection.
P5V_KL25Z	Power supplied from the KL25Z USB connector (J5). A Schottky diode provides back drive protection.
P3V3_VREG	Regulated 3.3V supply. Sources power to the P3V3 supply rail through a back drive protection Schottky diode. ¹
P3V3_BATT	Coin cell battery supply voltage. Sources power to the P3V3 supply rail through a back drive protection Schottky diode.
P3V3	Main supply rail for the FRDM-KL25Z assembly. May be sourced from P3V3_VREG, P3V3_BATT, or directly from the I/O headers (J9 pin 8)
P3V3_KL25Z	KL25Z MCU supply. Header J4 provides a convenient means for energy consumption measurements. ²
P3V3_SDA	OpenSDA circuit supply. Header J3 provides a convenient means for energy consumption measurements. ²
P5V_USB	Nominal 5V supplied to the I/O headers (J9 pin 10). Sourced from either the P5V_KL25Z or P5V_OSDA supply through a back drive protection Schottky diode.

NOTES:

1) By default the linear regulator, U1, is a 3.3V output regulator. However, this is a common footprint that would allow the user to modify the assembly to utilize an

alternative device such as a 1.8V or 2.5V regulator. The KL25Z microcontroller has an operating range of 1.71V to 3.6V.

2) J3 and J4 are not populated by default. The two pins of these headers are shorted together by a trace on the bottom layer of the PCB. To measure the energy consumption of either the KL25Z or the OpenSDA MCU, the trace between these pins must first be cut. A current probe or a shunt resistor and voltage meter can then be applied to measure the energy consumption on these rails.

5.2 Serial and Debug Adapter (OpenSDA)

OpenSDA is an open-standard serial and debug adapter. It bridges serial and debug communications between a USB host and an embedded target processor as shown in Figure 4. The hardware circuit is based on a Freescale Kinetis K20 family microcontroller (MCU) with 128 KB of embedded flash and an integrated USB controller. OpenSDA features a mass storage device (MSD) bootloader, which provides a quick and easy mechanism for loading different OpenSDA Applications such as flash programmers, run-control debug interfaces, serial-to-USB converters, and more. Refer to the *OpenSDA User's Guide* for more details.

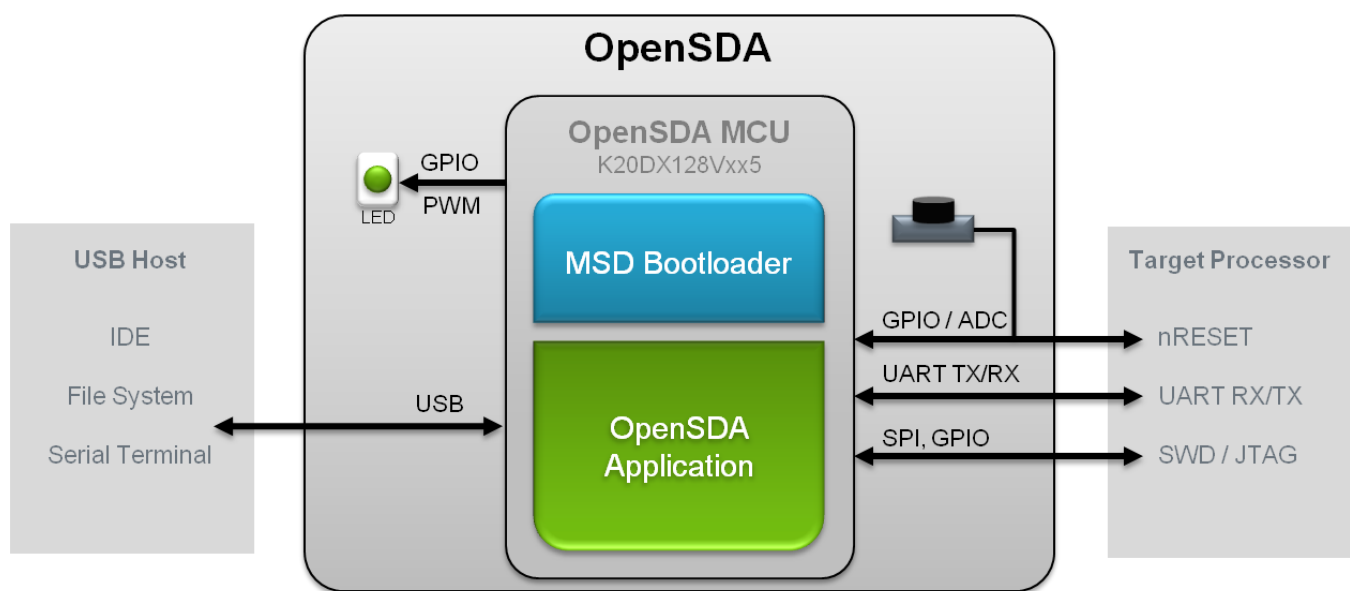

Figure 4. OpenSDA High-Level Block Diagram

OpenSDA is managed by a Kinetis K20 MCU built on the ARM® Cortex™-M4 core. The OpenSDA circuit includes a status LED (D4) and a pushbutton (SW1). The pushbutton asserts the Reset signal to the KL25Z target MCU. It can also be used to place the OpenSDA circuit into Bootloader mode. SPI and GPIO signals provide an interface to either the SWD debug port of the KL25Z. Additionally, signal connections are available to implement a UART serial channel. The OpenSDA circuit receives power when the USB connector J7 is plugged into a USB host.

5.2.1 Debug Interface

Signals with SPI and GPIO capability are used to connect directly to the SWD of the KL25Z. These signals are also brought out to a standard 10-pin (0.05") Cortex Debug connector (J6). It is possible to isolate the KL25Z MCU from the OpenSDA circuit and use J6 to connect to an off-board MCU. To

accomplish this, cut the trace on the bottom side of the PCB that connects J11 pin 1 to J11 pin 2. This will disconnect the SWD_CLK pin to the KL25Z so that it will not interfere with the communications to an off-board MCU connected to J6.

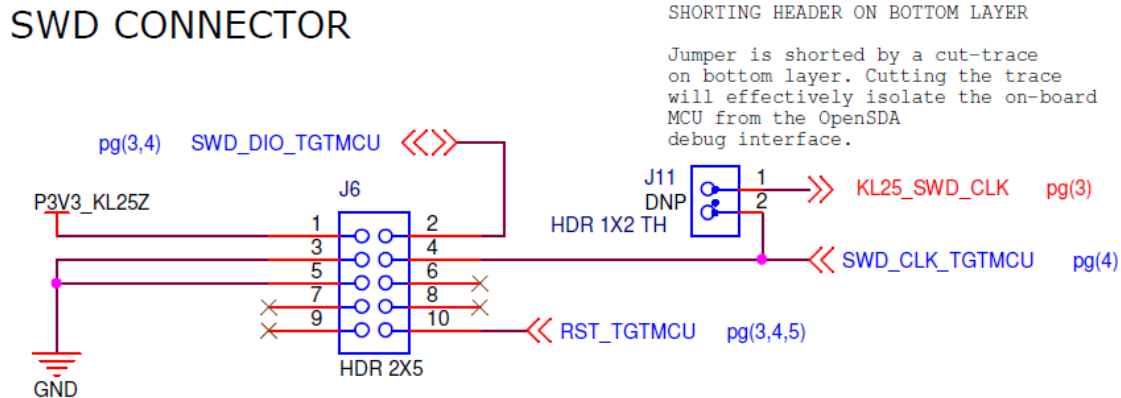

Figure 5. SWD Debug Connector

Note that J6 is not-populated by default. A Samtec FTSH-105-02-F-D or compatible connector can be added to the J6 through-hole connector. A mating cable, such as a Samtec FFSD IDC cable, can then be used to connect from the OpenSDA of the FRDM-KL25Z to an off-board SWD connector.

5.2.2 Virtual Serial Port

A serial port connection is available between the OpenSDA MCU and pins PTA1 and PTA2 of the KL25Z. Several of the default OpenSDA Applications provided by Freescale, including the MSD Flash Programmer and the P&E Debug Application, provide a USB Communications Device Class (CDC) interface that bridges serial communications between the USB host and this serial interface on the KL25Z.

5.3 KL25Z Microcontroller

The target microcontroller of the FRDM-KL25Z is the KL25Z128VLK4, a Kinetis L series device in an 80 LQFP package. The KL25Z MCU features include:

- 32-bit ARM Cortex-M0+ core
 - up to 48 MHz operation
 - Single-cycle fast I/O access port
- Memories
 - 128 KB flash
 - 16 KB SRAM
- System integration
 - Power management and mode controllers
 - Low-leakage wakeup unit
 - Bit manipulation engine for read-modify-write peripheral operations
 - Direct memory access (DMA) controller
 - Computer operating properly (COP) Watchdog timer
- Clocks
 - Clock generation module with FLL and PLL for system and CPU clock generation

- 4 MHz and 32 kHz internal reference clock
- System oscillator supporting external crystal or resonator
- Low-power 1kHz RC oscillator for RTC and COP watchdog
- Analog peripherals
 - 16-bit SAR ADC w/ DMA support
 - 12-bit DAC w/ DMA support
 - High speed comparator
- Communication peripherals
 - Two 8-bit Serial Peripheral Interfaces (SPI)
 - USB dual-role controller with built-in FS/LS transceiver
 - USB voltage regulator
 - Two I²C modules
 - One low-power UART and two standard UART modules
- Timers
 - One 6-channel Timer/PWM module
 - Two 2-channel Timer/PWM modules
 - 2-channel Periodic Interrupt Timer (PIT)
 - Real time clock (RTC)
 - Low-power Timer (LPT)
 - System tick timer
- Human-Machine Interfaces (HMI)
 - General purpose input/output controller
 - Capacitive touch sense input interface hardware module

5.3.1 Clock Source

The Kinetis KL2 microcontrollers feature an on-chip oscillator compatible with three ranges of input crystal or resonator frequencies: 32-40 kHz (low freq. mode), 3-8 MHz (high freq. mode, low range) and 8-32 MHz (high freq. mode, high range). The KL25Z128 on the FRDM-KL25Z is clocked from an 8 MHz crystal.

5.3.2 USB Interface

The Kinetis KL2 microcontrollers feature a dual-role USB controller with on-chip full-speed and low-speed transceivers. The USB interface on the FRDM-KL25Z is configured as a full-speed USB device. J5 is the USB connector for this interface.

5.3.3 Serial Port

The primary serial port interface signals are PTA1 and PTA2. These signals are connected to both the OpenSDA and to the J1 I/O connector.

5.3.4 Reset

The PTA20/RESET signal on the KL25Z128 is connected externally to a pushbutton, SW1, and also to the OpenSDA circuit. The reset button can be used to force an external reset event in the target MCU. The reset button can also be used to force the OpenSDA circuit into bootloader mode. Please refer to section 5.2, Serial and Debug Adapter (OpenSDA), for more details.

5.3.5 Debug

The sole debug interface on all Kinetis L Series devices is a Serial Wire Debug (SWD) port. The primary controller of this interface on the FRDM-KL25Z is the onboard OpenSDA circuit (see section 5.2). However, an unpopulated 10-pin (0.05") Cortex Debug connector, J6, provides access to the SWD signals. The Samtec FTSH-105-02-F-D or compatible connectors can be added to the J6 through-hole debug connector to allow for an external debug cable to be connected.

5.4 Capacitive Touch Slider

Two Touch Sense Input (TSI) signals, TSI0_CH9 and TSI0_CH10, are connected to capacitive electrodes configured as a touch slider. Freescale's Touch Sense Software (TSS) provides a software library for implementing the capacitive touch slider.

5.5 3-axis Accelerometer

A Freescale MMA8451Q low-power, three-axis accelerometer is interfaced through an I²C bus and two GPIO signals as shown in Table 4 below. By default, the I²C address is 0x1D (SA0 pulled high).

Table 4. Accelerometer Signal Connections

MMA8451Q	KL25Z128
SCL	PTE24
SDA	PTE25
INT1	PTA14
INT2	PTA15

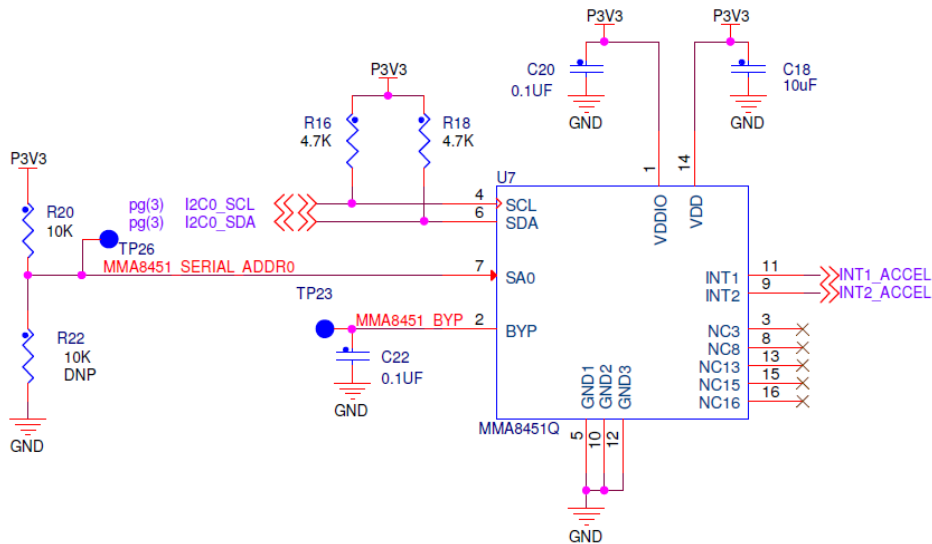

Figure 6. MMA8451Q Schematic Diagram

5.6 RGB LED

Three PWM-capable signals are connected to a red, green, blue LED, D3. The signal connections are shown in Table 5 below.

Table 5. RGB LED Signal Connections

RGB LED	KL25Z128
Red Cathode	PTB18
Green Cathode	PTB19
Blue Cathode	PTD1 ¹

NOTE:

1) PTD1 is also connected to the I/O header on J2 pin 10 (also known as D13).

RGB LED FEATURE

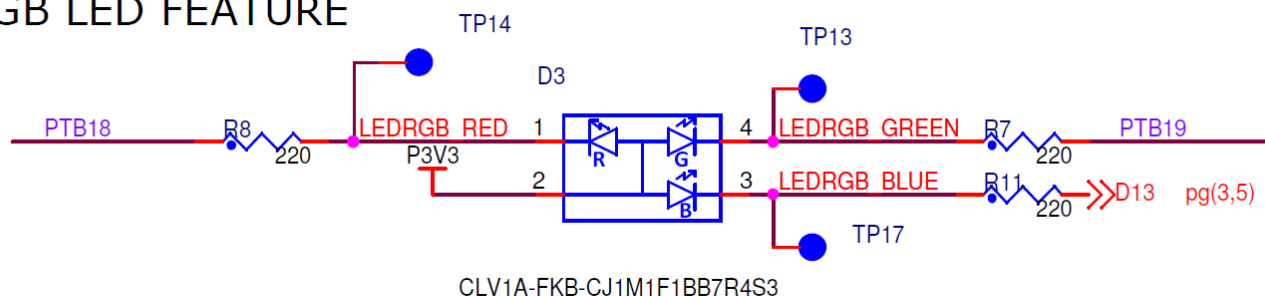
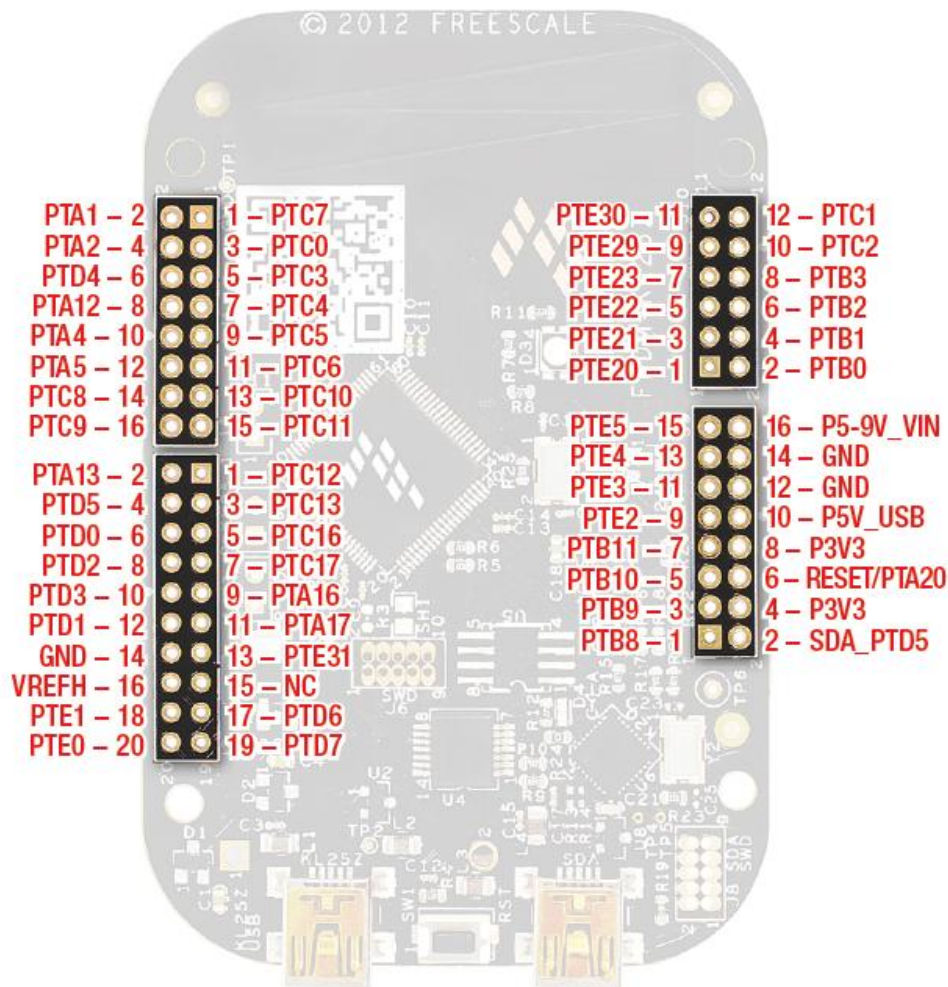

Figure 7. RGB LED Schematic Diagram

5.7 Input/Output Connectors

The KL25Z128VLK4 microcontroller is packaged in an 80-pin LQFP. Some pins are utilized in on-board circuitry, but many are directly connected to one of four I/O headers.

The pins on the KL25Z microcontroller are named for their general purpose input/output port pin function. For example, the 1st pin on Port A is referred to as PTA1. The I/O connector pin names are given the same name as the KL25Z pin connected to it, where applicable.



Note that all pinout data is available in spreadsheet format in *FRDM-KL25Z Pinouts*. See the Reference Documents section for details.

5.8 Arduino Compatibility

The I/O headers on the FRDM-KL25Z are arranged to allow compatibility with peripheral boards (known as shields) that connect to Arduino™ and Arduino-compatible microcontroller boards. The outer rows of pins (the even numbered pins) on the headers share the same mechanical spacing and placement as the I/O headers on the Arduino Revision 3 (R3) standard.

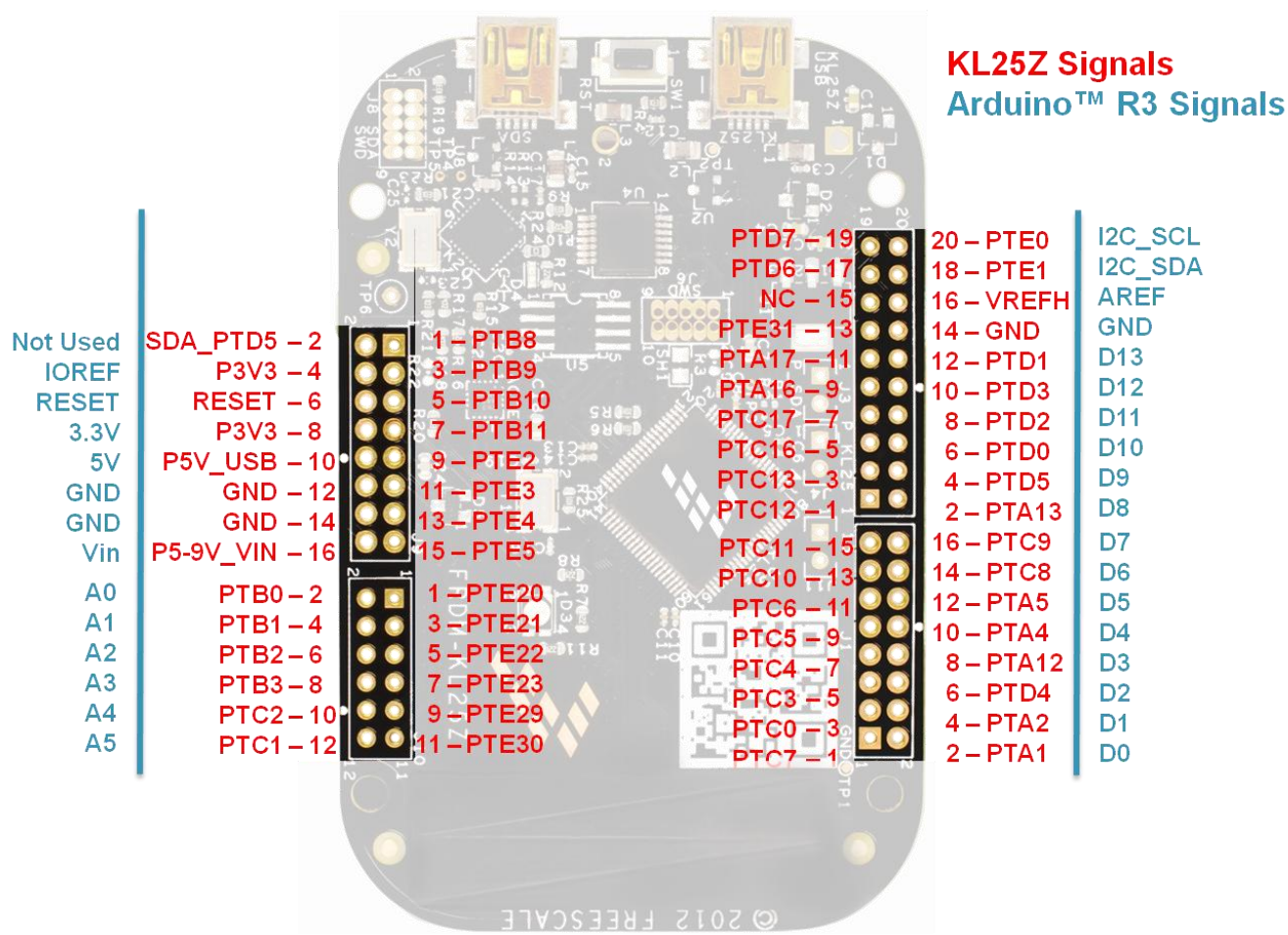

Refer to the *FRDM-KL25Z Pinouts* spreadsheet for a compatibility chart showing how all the functions of the KL25Z signals on the I/O connectors map to the pin functions available on the Arduino Uno R3.

How to Reach Us:

Home Page:
freescale.com

Web Support:
freescale.com/support

Information in this document is provided solely to enable system and software implementers to use Freescale products. There are no express or implied copyright licenses granted hereunder to design or fabricate any integrated circuits or integrated circuits based on the information in this document.

Freescale reserves the right to make changes without further notice to any products herein. Freescale makes no warranty, representation or guarantee regarding the suitability of its products for any particular purpose, nor does Freescale assume any liability arising out of the application or use of any product or circuit, and specifically disclaims any and all liability, including without limitation consequential or incidental damages. "Typical" parameters that may be provided in Freescale data sheets and/or specifications can and do vary in different applications and actual performance may vary over time. All operating parameters, including "Typicals", must be validated for each customer application by customer's technical experts. Freescale does not convey any license under its patent rights nor the rights of others. Freescale sells products pursuant to standard terms and conditions of sale, which can be found at the following address:
<http://www.reg.net/v2/webservices/Freescale/Docs/TermsandConditions.htm>

Freescale, the Freescale logo, Altivec, C-5, CodeTest, CodeWarrior, ColdFire, C_Ware, Energy Efficient Solutions logo, Kinetis, mobileGT, PowerQUICC, Processor Expert, QorIQ, Qorriva, StarCore, Symphony, and VortiQa are trademarks of Freescale Semiconductor, Inc., Reg. U.S. Pat. & Tm. Off. Airfast, BeeKit, BeeStack, ColdFire+, CoreNet, Flexis, MadniV, MXC, Platform in a Package, QorIQ Qonverge, QUICC Engine, Ready Play, SafeAssure, SMARTMOS, TurboLink, Vybrid, and Xtrinsic are trademarks of Freescale Semiconductor, Inc. All other product or service names are the property of their respective owners.



© Freescale Semiconductor, Inc. 2012. All rights reserved.

FRDMKL25ZUM
Rev. 0.90
2012-09-24

X-ON Electronics

Largest Supplier of Electrical and Electronic Components

Click to view similar products for [Development Boards & Kits - ARM category](#):

Click to view products by [Seeed Studio manufacturer](#):

Other Similar products are found below :

[SAFETI-HSK-RM48](#) [PICOHOBBITFL](#) [CC-ACC-MMK-2443](#) [TWR-MC-FRDMKE02Z](#) [EVALSPEAR320CPU](#) [EVB-SCMIMX6SX](#)
[MAX32600-KIT#](#) [TMDX570LS04HDK](#) [TXSD-SV70](#) [OM13080UL](#) [EVAL-ADUC7120QSPZ](#) [OM13082UL](#) [TXSD-SV71](#)
[YGRPEACHNORMAL](#) [OM13076UL](#) [PICODWARFFL](#) [YR8A77450HA02BG](#) [3580](#) [32F3348DISCOVERY](#) [ATTINY1607](#) [CURIOSITY](#)
[NANO](#) [PIC16F15376](#) [CURIOSITY NANO BOARD](#) [PIC18F47Q10](#) [CURIOSITY NANO](#) [VISIONSTK-6ULL V.2.0](#) [80-001428](#) [DEV-17717](#)
[EAK00360](#) [YR0K77210B000BE](#) [RTK7EKA2L1S00001BE](#) [MAX32651-EVKIT#](#) [SLN-VIZN-IOT](#) [ETTUS USRP B200MINI](#) [USB-202](#)
[MULTIFUNCTION DAQ DEVICE](#) [USB-205 MULTIFUNCTION DAQ DEVICE](#) [ALLTHINGSTALK LTE-M RAPID DEV. KIT](#) [LV18F V6](#)
[DEVELOPMENT SYSTEM](#) [READY FOR AVR BOARD](#) [READY FOR PIC BOARD](#) [READY FOR PIC \(DIP28\)](#) [EVB-VF522R3](#)
[AVRPLC16 V6 PLC SYSTEM](#) [MIKROLAB FOR AVR XL](#) [MIKROLAB FOR PIC L](#) [MINI-AT BOARD - 5V](#) [MINI-M4 FOR STELLARIS](#)
[MOD-09.Z](#) [BUGGY + CLICKER 2 FOR PIC32MX + BLUETOOT](#) [1410](#) [LETS MAKE PROJECT PROGRAM. RELAY PIC](#) [LETS MAKE -](#)
[VOICE CONTROLLED LIGHTS](#) [LPC-H2294](#)