



Robovie-X

ASSEMBLY MANUAL

ver.1.11b

Vstone

0. INTRODUCTION

READ FIRST

Thank you for purchasing our bipedal robot assembly kit “Robovie-X.” The Manual describes assembly of the robot and handling of its accessories. Read it thoroughly to assemble the Product with care.

- The Product is an assembly kit. It may not be able to exhibit its intended performance depending on how you assemble it. If you cannot assemble it properly, utilize our support services. For details, see Page 71 “9. INQUIRIES ABOUT TROUBLES, MISSING PARTS, DAMAGE, ETC.”

- Assembly and operation of the Product assumes use of a personal computer (hereinafter, to be referred to as the PC). The Manual and other accompanying manuals have been prepared, assuming that you are familiar with basic operation of the PC. Note that we cannot answer any questions or inquiries about operation of the PC or Windows.

***The specifications are subject to change without prior notice due to improvement or enhanced performance.**

PRECAUTIONS PRIOR TO ASSEMBLY

- Note that the Product is an assembly kit and does not always assure robot operations after its assembly.
- When you use, assemble or store the Product and its parts, make sure that there are not infants around you. The Product comes with small parts. Care should be taken so that they will not swallow them by mistake.
- The Product is not a toy. When it is operated by a child, his/her parent must be present to watch.
- Do not wet the Product or its part, or use/store them at high humidity or in an environment where due condensation may occur.
- Use the tools with utmost care paid to safety.
- Do not disassemble or remodel servo motors and PC boards because they are precision electronic parts. Neglect of this may cause a trouble or a resultant electric shock or fire.
- Care should be taken not to allow conductive foreign substances into contact with the PC boards.
 - As the terminals of the PC boards are exposed, they can be easily short-circuited by conductive foreign substances (metals, water, etc.). Short-circuit could result in a PC board failure or ignition of the battery or wiring.
- When you adjust or operate the Product after its assembly, it may move in an unexpected way in the nature of the assembly it. It may tumble or drop to injure you or get damaged. Secure sufficient work space and operate. Handle the Product with utmost care because it may catch your finger while operating.
- Connect the connectors securely, paying attention to their polarity. Neglect of this could cause a trouble or fire.
- Do not allow the cables to be caught when assembling. Catching of the cable could cause snapping or short-circuit.
- When disconnecting a cable, hold its plug and connector.

If it is disconnected by holding its cord, an electric shock or fire may be caused by snapping or short-circuit.
- For handling of the battery and battery charger, be sure to observe the instructions described in the Instruction Manual, Robovie-X Assembly Manual and Robovie-X Software Reference.

1. CONTENTS

0. INTRODUCTION	1
1. CONTENTS	3
2. UTENSILS REQUIRED	4
3. ACCESSORIES	5
3-1. Major Parts	5
3-2. List of Parts Used	6
4. CHARGER AND BATTERY	11
4-1. Precautions for Handling	11
4-2. Charging Method	12
5. PRELIMINARY KNOWLEDGE PRIOR TO ASSEMBLY	13
5-1. Servo Motor Origin	13
5-2. Screws and Precautions for Screwing	14
6. SETTING OF SERVO MOTOR ORIGIN	15
7. ASSEMBLY	18
7-1. Assembling the Right Arm	21
7-2. Assembling the Left Arm	23
7-3. Assembling the Right Leg	25
7-4. Assembling the Left Leg	31
7-5. Assembling the Body	37
7-6. Mounting the Arms and Legs to the Body	44
7-7. Checking the Movable Ranges	54
7-8. Wiring and Mounting the Head Armor	58
7-9. Mounting the Body Armor	64
7-10. Pasting the Sole Tape	69
8. INSTALLATION OF BATTERY	70
9. INQUIRIES ABOUT TROUBLES, MISSING PARTS, DAMAGE, ETC.	71
APPENDIX: EXTENSION OF FUNCTIONS	72

2. UTENSILS REQUIRED

The following utensils are required for assembly and operation of the Product.
Prepare them in advance.

•PC (Personal Computer)

CPU: Pentium 3 or later (1 GHz or more recommended)
RAM: 128 MB
OS: Windows 2000/XP/Vista
Screen size: XGA or above
Interface: USB
Should be equipped with a CD-ROM drive.

•Tools

- Cutting pliers (used in "7-5. Assembling the Body, Step 15" on Page 43)
- Scissors (used in "7-10. Pasting the Sole Tape" on Page 69)
- Screwdrivers
 - No. 1 Phillips screwdriver (handle diameter = 1 cm or more)
 - No. 0 and No. 1 Phillips precision screwdrivers



Precision Screwdrivers

Other Useful Utensils

Regular screwdrivers, tweezers, towel, Scotch tape, screw container

3. ACCESSORIES

3-1. Major Parts

The following outlines the specifications of the main parts included in the Product.

Servo motor VS-S092J

Dimensions : 38 x 19 x 38.5mm
Torque:9.2kg cm
Speed:0.11S/60 °
Weight:42g
Max. operating range:180 °
Max. voltage: 4 V to 9 V (7.4 V measured)
Control method:PWM



Small CPU board for the robot VS-RC003HV

Dimensions:52x48(44)x13mm
Weight:21g
Servo motor output:30ch
Audio output:2W
Corresponding voltage 5 V to 16 V
Interface with PC:USB (HID)
Corresponding controller: Game pad, ProBo
Extension port:IXBUS x1



Battery

Nickel metal hydride battery
1,400 mAh, 5 cells (6.0 V)



(Option)

Gyro sensor/acceleration sensor extension board VS-IX001

Dimensions: 25 x 30mm
Mounted sensors: 2-axis gyro sensor
3-axis acceleration sensor

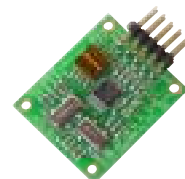

3-2. List of Parts Used

Check if all the component parts are included.

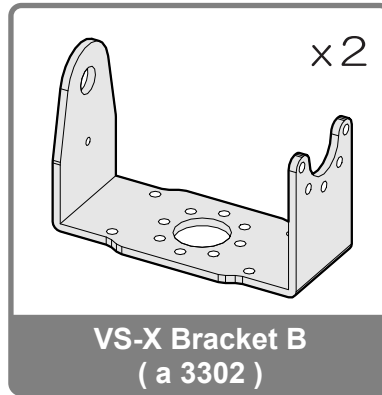
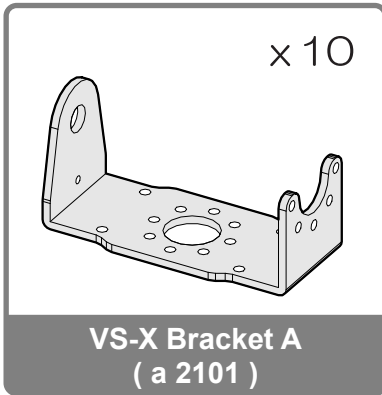

* Note that the brackets A and B are very similar to each other.

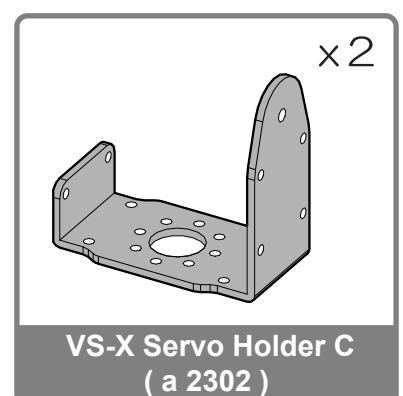
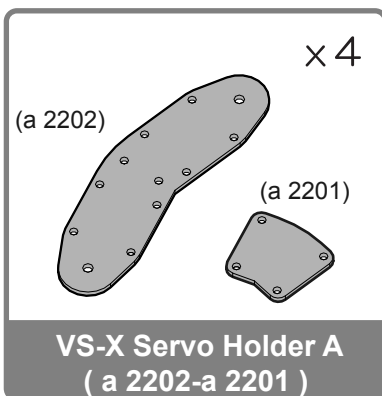
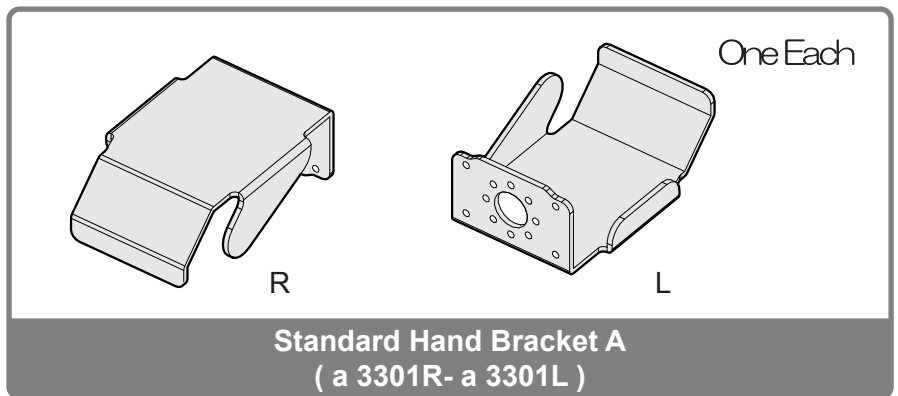
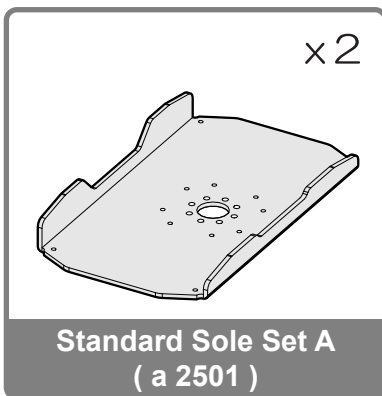
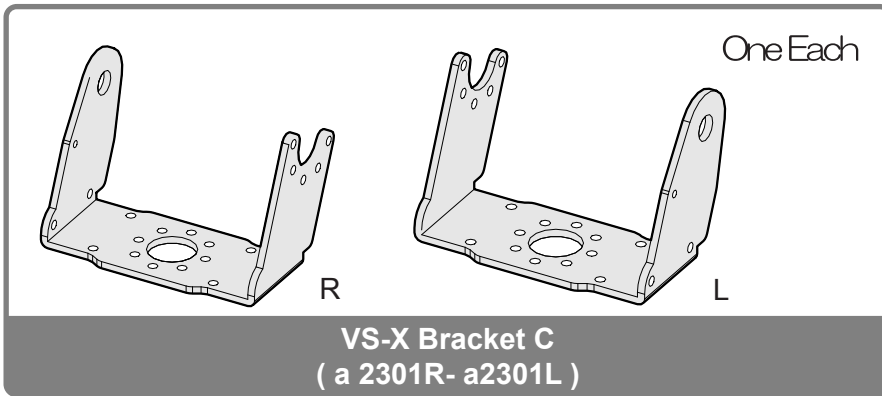

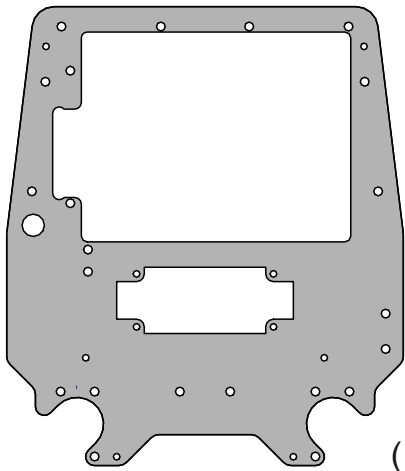

(a 1101)

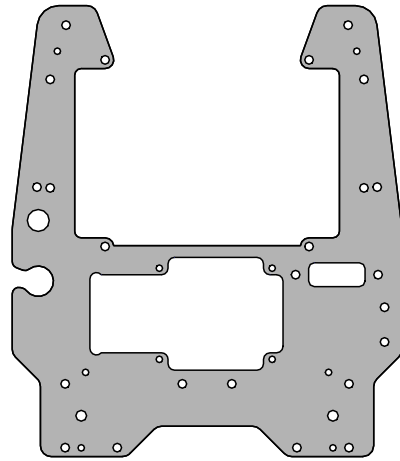

(a 1102)

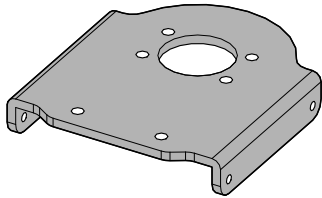

(a 1103) ※

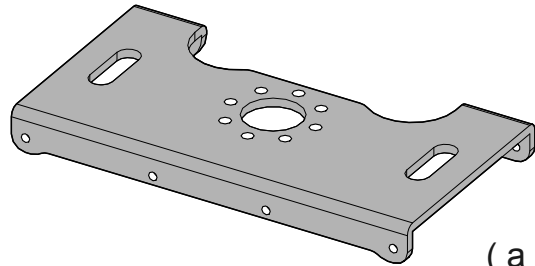

(a 1104) □

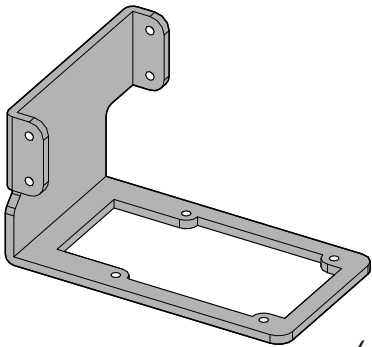

(a 1107)

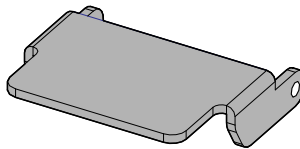

(a 1106)

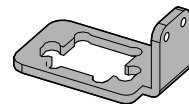

(a 1105)

VS-X Standard Body Set

One Each

※ (a 1103) x 2

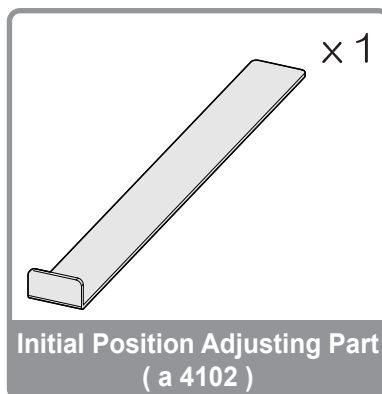

Initial Position Adjusting Part
(a 4102)

One Each

Front of Head

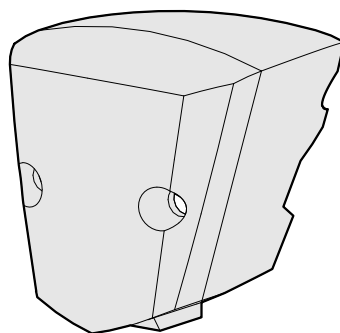

Rear of Head

Front Head Armor

Rear Head Armor

One Each

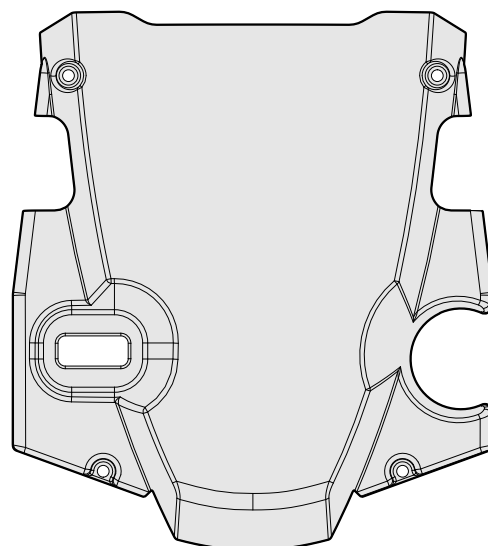
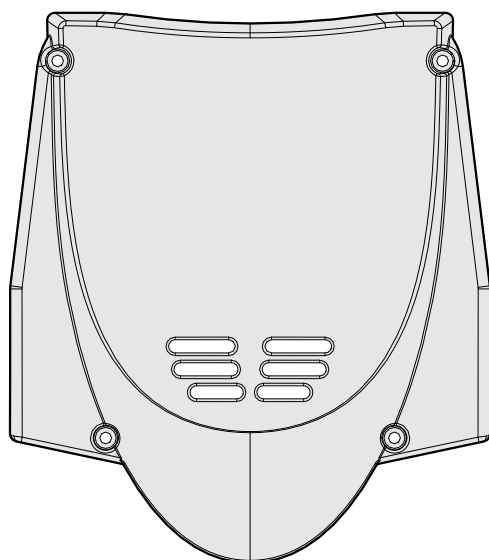

Front Body Armor

Rear Body Armor

× 1



Decal

Major Parts

x 1



CPU Board
VS-RC003HV

x 1



USB Cable

x 1



Power Cable

x 1



Battery

x 1



Charger

x 10



Long Cable 40cm

x 7



Short Cable 15cm

Servo Motor VS-S092J

x 25



Servo Horn

x 1



Game Pad
Conversion Connector

x 1





Speaker

x 2



LED Board
VS-LED1

(Optional Part)



This part allows the robot to automatically balance itself to prevent tumbling.

Gyro Sensor/Acceleration Sensor Extension Board
VS-IX001

x 1



Sole Tape

Screws

M2-3 × 62*
(3)



Screw A
M2-3 Flat Pan Head

M2-4 T × 54
(3)



Screw F
M2-4 Flat Head Tapping

M2-5 T × 134
(4)



Screw E
M2-5 Flat Head Tapping

M2-4 B × 12
(1)



Screw G
M2-4 Bind Tapping

M3-5 × 16
(1)



Screw C
M3-5 Flat Pan Head Cap

M3-8 T × 17
(1)



Screw H
M3-8 Flat Head Tapping

- T** Tapping screw
- B** Bind tapping screw
- S** Spacer□

M2-3 S × 2



Spacer A
M2-3 (Hexagonal Spacer)

M2-5 × 4



Spacer B
M2-5 (Hexagonal Spacer)

× 1



Urea Resin

× 1



Urea Resin Nut

× 14



Friction Rubber

× 16
(1)



Bush

× 2



DURACON Washer

× 18
(2)



Binding Band

× 18
(2)



Binding Band Washer

× : Denotes the required quantity.
Parenthesized is the number of spare parts.

The Product includes the total of both.
*Four of them are for the optional part.

4. CHARGER AND BATTERY

4-1. Precautions for Handling

Mishandling of the charger and battery may cause a liquid leak, ignition, trouble or injury. Prior to using them, read the following precautions carefully.

- Store them beyond child's reach.

- Check the polarity of the battery to connect it.
- Never short-circuit the battery.

(If the battery is stored together with a metal or a conductive substance, it may be damaged by the conductive substance due to certain disturbance, resulting in short-circuit. When carrying them together, put the battery in a separate case.)

- Do not wet or put the battery in water or sea water.

- Do not use or store the battery in a high-temperature, high-humidity place.
- Do not leave the battery for a long time, connected to the robot.

After using, be sure to turn off the switch of the robot.

- If the battery is not used, remove it from the robot and store it in a place with normal temperature (0 to 30°C) and low humidity.

- Charge the battery at its temperature of 0 to 40°C. It is dangerous if the temperature exceeds 40°C. Cool the battery with a cooling device.

- If you notice abnormal heat generation, foul smell or smoke while charging, stop charging immediately.

- If you notice abnormal heat generation, foul smell or smoke while using the battery, turn off the switch immediately and remove the battery from the robot.

- If you notice a liquid leak from the battery or its discoloration, deformation, foul smell or other abnormality, do not use it.

- If the battery cannot be fully charged after the specified charging time, stop charging.

- After charging is completed, disconnect the battery immediately from the charger.

- Do not throw the battery into fire, heat it or deform it.

- Do not disassemble or remodel the battery.

- Do not peel off or damage the coating tube of the battery.

- Do not remodel a connector, etc.

- Use the charger only for the purpose of charging.

- Never use the charger as a DC power source.

- If the battery liquid gets into the eye, rinse it fully with clean tap water immediately and consult a medical doctor.

- If the battery liquid adheres to the skin or clothing, rinse them fully with clean tap water immediately.

- The battery is basically accompanied by danger. As it could lead to a fire, do not leave it while it is charged.

- Do not connect the fully charged battery to the charger.

- The nickel metal hydride battery may be out of service as a battery, once the voltage of each cell is 1 V or less (5 V or less for this battery because it has 5 cells).

If it is charged in this condition, it may be damaged.

The battery voltage may drop to 5 V or less momentarily while it is operating, but it is no problem, just a voltage drop due to the running current.

4-2. Charging Method

The battery is used at the time of assembly. Start charging prior to assembly.
(Charging is completed in a couple of hours.)

<Recheck>

- Use only the accompanying charger for the Robovie-X battery.
- Do not charge the battery near any combustible or inflammable substances.
- Do not leave the battery while it is being charged.
- **Do not connect the fully charged battery to the charger.**
- If you notice foul smell or abnormal heat generation, unplug the power source immediately and disconnect the battery.
When this is done, be careful not to get burnt.

•Utensils required: Charger, conversion connector, battery

- 1. Plug a Robovie-X exclusive conversion connector to the charger.



- 2. **Connect the AC plug of the rechargeable battery to a plug socket and connect the battery, paying attention to the polarity.**

- 3. A red lamp is lit up, starting charging.



- 4. Once the battery is fully charged, a green lamp will be lit up, automatically switching to **trickle charging***.

At this point, disconnect the battery from the charger.

- 5. Once charging is completed, be sure to disconnect the battery connector and the AC plug from the plug socket.

Features of Battery (Nickel Metal Hydride Rechargeable Battery)

- Natural discharge (self-discharge)

A battery discharge naturally as time passes, even if it is not used. If it is not used for a long time, it may completely discharge, running out of service. If not used for a long time, store it fully charged. Measure its voltage from time to time to ensure that its voltage is not 5 V or less. (Check every couple of months.) The voltage can be measured with included software "RobovieMaker2."

- Memory effect

When using the robot, the battery may run out in a short time, even if it is fully charged. If the nickel metal hydride battery is frequently recharged (top-up charging) before its recharged capacity is used up, it may show an out-of-battery phenomenon, even if it still has a remaining capacity. This is called a memory effect.

In order to prevent this effect, it is recommended to charge the battery after using up its capacity.

The memory effect can be controlled by refresh charging (charging after discharging) after using several times. If you feel that the battery capacity is lower, use it up to the last (until the battery voltage will be 5 V to 6 V).

Trickle charging*

A charging method to always run a minute electric current, separated from the load, in order to compensate for natural discharge of the battery.

5. PRELIMINARY KNOWLEDGE PRIOR TO ASSEMBLY

5-1. Servo Motor Origin

A servo motor has an important rule and concept concerning its mounting. If it is mounted in a wrong way, the robot will not move correctly. When assembling the servo motor, read this page thoroughly.

The servo motor is controlled by the CPU and can be programmed by the user to freely run. The servo motor VS-S092J used for the Product has frame mounting holes in the top and back covers, into which a frame is mounted. Then, mount a servo horn to an output shaft (power supplied shaft), followed by the frame there, to use it as the robot's joint. A movable range of the robot's joint depends on this mounting of the servo horn.

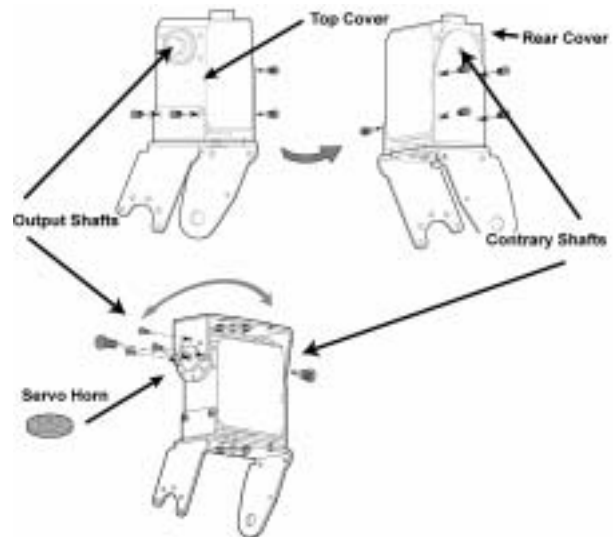

Neutral Mark

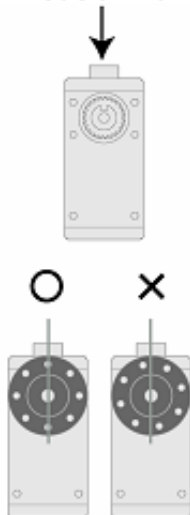

The servo motor has its movable range. The VS-S092J used for the Product moves within a range of about 180° , that is from -90° to $+90^\circ$.*

The central position of 0° is called the "origin." If you look at the servo motor, you can see a concave mark on the output shaft. This is called a **"neutral mark."** When the servo motor is at the origin, the neutral mark is basically located almost directly above. (see the left figure).

However, each servo motor has a slight angle discrepancy. Even if the angle of the origin is sent from the CPU board to the servo motor, it may be slightly dislocated from the origin. Assuming that the origin position based on a signal from the CPU board is correct, this robot uses software to adjust an error produced in the actual servo motor. (An error adjusting method is described later.)

In the following description, **"origin" is used as the "origin set by the CPU board."** In addition to this, an error also results from wrong mounting of the servo horn. There are 8 holes in the servo horn. The parts such as the frame are assembled into them to transmit the power to the robot. A servo horn mounting angle to the origin is important in order to set a movable range of the joint more accurately.

As a test, push in the servo horn so that a hole in the servo horn will be located at the origin of the servo motor (directly above). It should be slightly dislocated from the origin position. It is because the servo horn is not properly aligned with the serration which conveys rotation of the servo motor to the servo horn. There are intentionally 23 serration teeth on the circumference. If the number is increased or decreased by 3 teeth, the hole position in the servo horn differs delicately. Try each hole in the servo horn one after another until it is located at the most accurate angle to the origin (directly above). **There should be a hole which allows the servo horn to be located almost directly above. At the time of assembly, be sure to carry out this work. If the origin is not accurately set, the robot cannot move successfully in motions, such as getting up, which require an accurate movable range.** (This assembly work almost requires a hole in the servo horn to be located directly above. If it is required to be mounted at a different position, however, we will instruct you to that effect.)

When mounting the servo horn to the output shaft, do not allow the servo motor's output shaft to be rotated.

*An operating angle differs depending on the type of the servo motor.

5-2. Screws and Precautions for Screwing

• Types and Notation of Screws

M2 indicates that a thread diameter is 2 mm, and M3 indicates 3 mm.

A number following “-” indicates the length (mm) of threads.

Flat pan head and flat head indicate the shape of screw head. **Tapping screws refer to the screws with rough thread pitches and are mainly used for fixing the resin (servo horn, servo motor cover, servo motor output shaft).** Non-tapping screws are used for the areas where ordinary threads have been cut (metal parts).

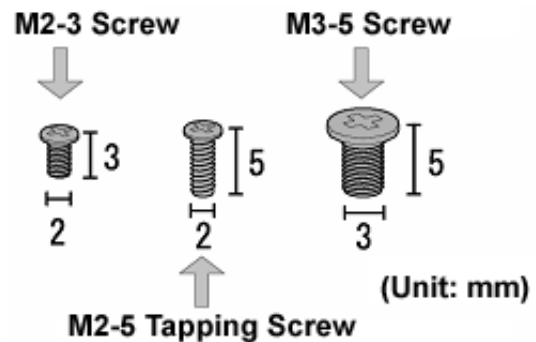

Note that if the tapping screws and ordinary ones are confused with each other, the parts will be damaged.

As the tapping screws are used for fixing the resin, the tapped holes are damaged by tightening them hard or putting them into the holes at a slant. Put the screws into the objective material perpendicularly and stop tightening them when all the threads have entered into the tapped holes.

Even when using ordinary screws to fix the objective material made of soft metal such as aluminum, the tapped holes are damaged by tightening them too much.

• Screws and Screwdrivers

Be sure to use appropriate screwdrivers to turn the screws. They may be turned with a different size of screwdriver, but the threads could be damaged.

No. 0 Phillips precision screwdriver: M2 screws (other than M2-4 bind tapping screws)

No. 1 Phillips precision screwdriver: M2-4 bind tapping screws, M3-5 screws

No. 1 Phillips screwdriver: M3-8 tapping screws

• Precautions for Using the Servo Horn to Fix the Parts

The frame of Robovie-X has been flexibly designed so that it can be changed into different forms. For this reason, two frames may be combined together for use. In this case, the servo horn is mainly used to assemble.

When this is done, **be sure to hold the horn from below and screw in the vertical direction.** The parts are almost mutually fixed by tightening one screw. Remember to tighten the remaining screws, holding the horn from below.

Do not tighten the screws too hard because the servo horn is made of resin. Threads are damaged by tightening too hard.



Use of Screw Locking Agent

Once you start moving the robot, its screws may be loosened. A “screw locking agent” is often used to prevent loosening of the screws, but its anaerobic and vinyl acetate properties tend to melt the resin. Use it only for the areas where metals parts are mutually screwed.

Do not use it for locking the screws of the output shaft and the servo horn.

When using an anaerobic screw locking agent, “medium strength” is recommended.



Locktite

6. SETTING OF SERVO MOTOR ORIGIN

- Utensils Required
CPU, USB cable, recharged battery, power connector, accessory CD

Note:

- Work with the CPU on an insulator.

(A pink-colored cushioning material, in which the CPU was contained, is an insulator.)

- When disconnecting a connector connected to the CPU, hold the connector itself, not a cable.

Procedure

1. Setting up the PC

Seeing "2. INSTALLATION OF SOFTWARE" on Page 3 and "3. CONNECTION OF CPU BOARD TO PC"

on Page 5 of the "Robovie-X Software Reference," install Robovie-Maker2 and make it recognize the CPU.

2. Connect servo motor to the CPU.

Connect to the connector encircled in red so that a gray cable will be located inside.

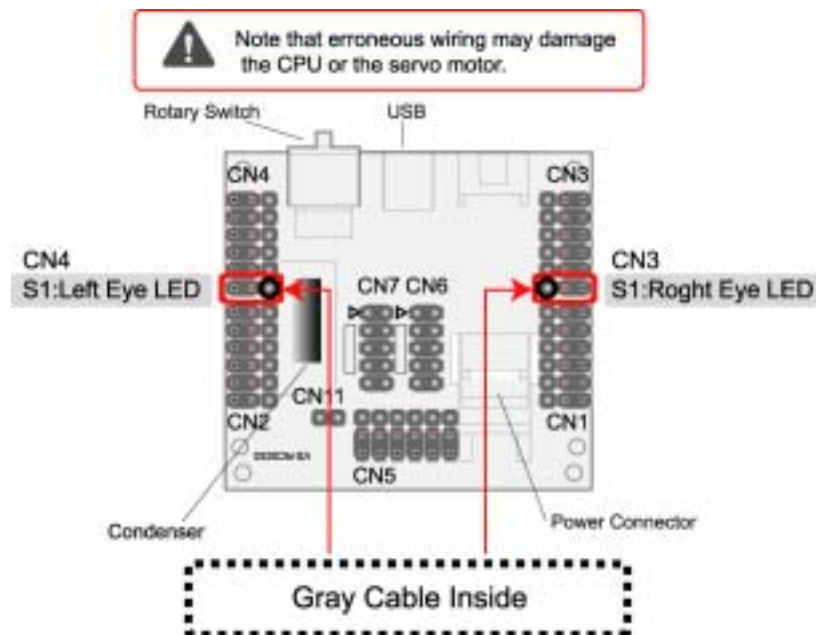

3. Connect the battery to the CPU.

Attach the power connector to the CPU. (A clicking sound is heard.)

Confirm that the switch has been turned off (to the battery side).

Connect the battery to the power connector.

4. Use the USB cable to connect the CPU to the PC.

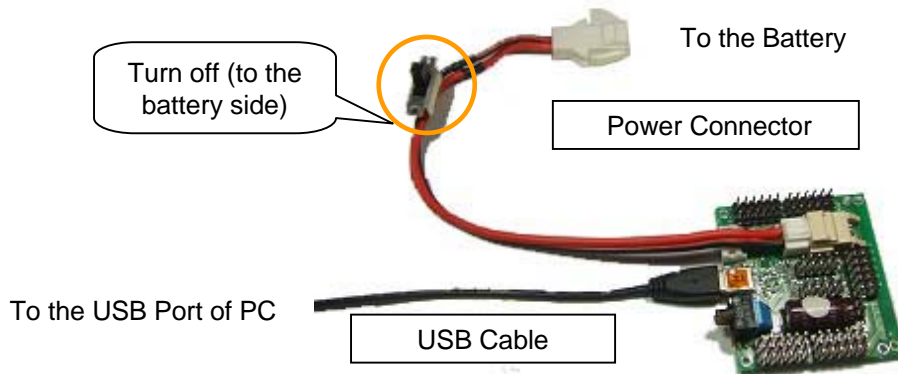

5. Start Robovie-Maker 2.



Tool Bar

The tool bar is available for the operational steps implemented in the rest of the procedure.

6. Press the communication button  on the tool bar.
Confirm that the following window appears.



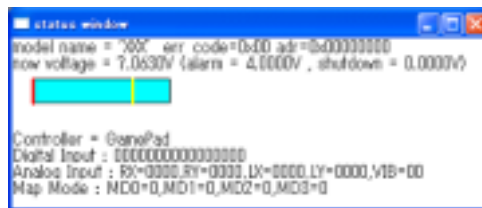

7. Turn on the Power switch (to the CPU side).
Confirm that an indication of a voltage gauge exceeds a yellow line.



8. Press the servo motor ON/OFF button  to turn on the servo motor.
The servo motor is activated.
Confirm that the neutral marks of all the servo motors are located almost directly above the servo motors.
(There are individual errors.)
See “5-1. Servo Motor Origin” on Page 13.

9. Seeing Step 2, replace the servo motor to do this operation for all the servo motors.
Note: Pay attention to the polarity. The gray cable should be located inside.
Erroneous wiring may damage the CPU and the servo motor.

10. Press the servo motor ON/OFF button  to turn off the servo motors.
Press the communication button  to end communication.

11. Terminate Robovie-Maker2.

12. Turn off the switch and disconnect the battery.
When disconnecting the battery and the power connector, hold down an upper claw and hold a connector to pull out.

13. Disconnect the CPU from the PC.
Disconnect the servo motors from the CPU

Now, you are ready to assemble.

7. ASSEMBLY

•Precautions

- Use appropriate screwdrivers.

No. 0 Phillips precision screwdriver: M2 screws (other than M2-4 bind tapping screws)

No. 1 Phillips precision screwdriver: M2-4 bind tapping screws, M3-5 screws

No. 1 Phillips screwdriver: M3-8 tapping screws

- Care should be taken not to confuse the types of screws.

The M2-4 and M2-5 tapping screws are very similar. Note that if the M2-5 tapping screws are used on the servo horn side of the output shaft, the robot may go out of order.

- There are two kinds of servo motors with different lengths of cables. Use those with longer cables, unless otherwise specified.

- When fitting the servo horn into the servo motor, do so several times so that it will be located at an accurate angle to the origin. Otherwise, the robot's joint may not move to the desired position, failing to successfully replay motions.

Assembly procedure

Assemble the robot in the following order:

- (1) Assembling the right arm
- (2) Assembling the left arm
- (3) Assembling the right leg
- (4) Assembling the left leg
- (5) Assembling the body
- (6) Mounting the arms and legs to the body
- (7) Checking the movable ranges
- (8) Mounting the head armor / Wiring
- (9) Mounting the body armor
- (10) Pasting the Sole Tape

Servo Motor Mounting Positions

Name of Axes

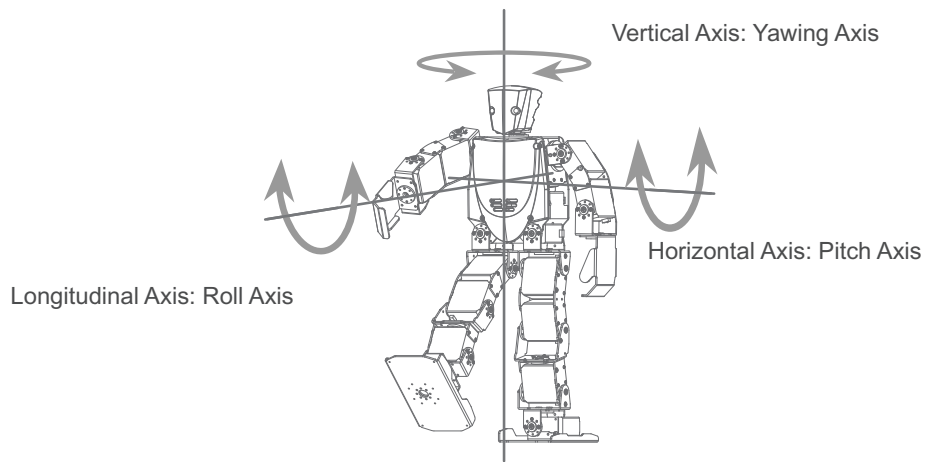

CN5

S3: Head Yawing Axis

CN3

S6: Right Shoulder Pitch Axis

S5: Right Shoulder Roll Axis

S4: Right Elbow Roll Axis

S3:

S2:

S1: Right Eye LED

CN4

S6: Left Shoulder Pitch Axis

S5: Left Shoulder Roll Axis

S4: Left Elbow Roll Axis

S3:

S2:

S1: Left Eye LED

CN1

S6:

S5: Right Thigh Roll Axis

S4: Right Thigh Pitch Axis

S3: Right Below Knee Pitch Axis

S2: Right Ankle Pitch Axis

S1: Right Ankle Roll Axis

CN2

S6:

S5: Left Thigh Roll Axis

S4: Left Thigh Pitch Axis

S3: Left Below Knee Pitch Axis

S2: Left Ankle Pitch Axis

S1: Left Ankle Roll Axis

(S) : Use a short cable

Notation of Icons

! Requires attention.

T Tapping screw

B Bind tapping screw

S Spacer

No notation: Ordinary screw

Notation Screws

M2-3 Screw A,
M2-3 Flat Pan Head

M3-5 Screw C,
M3-5 Flat Pan Head Cap

M2-4 T Screw F,
M2-4 Flat Head Tapping

M3-8 T Screw H,
M3-8 Flat Head Tapping

M2-5 T Screw E,
M2-5 Flat Head Tapping

M2-3 S Spacer A,
M2-3 (Hexagonal Spacer)

M2-4 B Screw G,
M2-4 Bind Tapping

M2-5 S Spacer B,
M2-5 (Hexagonal Spacer)

Example of Assembling the Servo Motor and the Frame

-1. Mount the servo horn accurately.

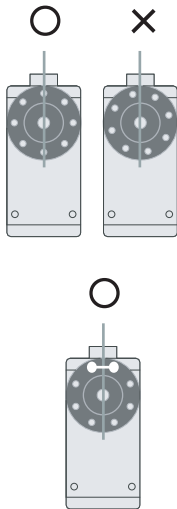

A middle point of two holes may be aligned with the origin.
(Thigh pitch axis)

-2. Mount a bush and a free horn to the contrary axis.

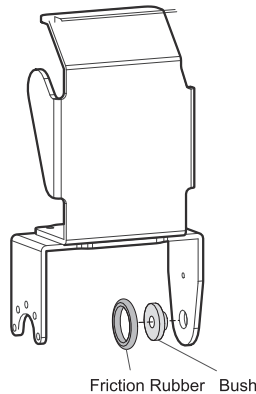

Friction Rubber Bush

-3. Mount the frame in the indicated direction.

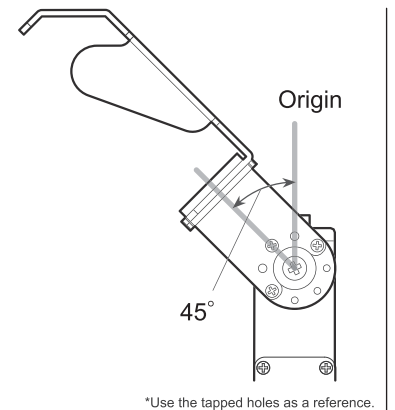

*Use the tapped holes as a reference.

[Frame Mounting Position against the Origin]

-4. Mount the frame to the servo horn with M2-4 tapping screws.

! Be careful not to confuse them with M2-5 tapping screws.

-5. Fix the output shaft with an M3-8 tapping screw.

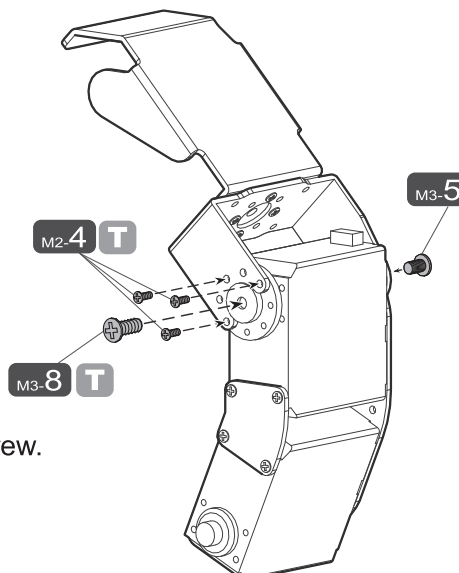

-6. Fix the contrary axis with an M3-5 screw.

7-1 Assembling the Right Arm

Prepare the required parts.

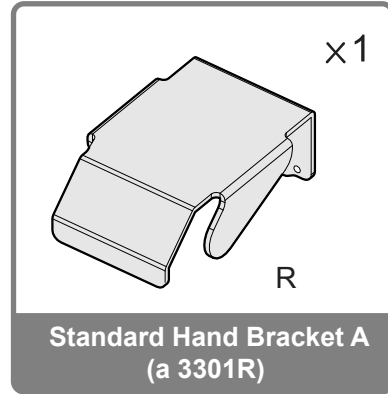
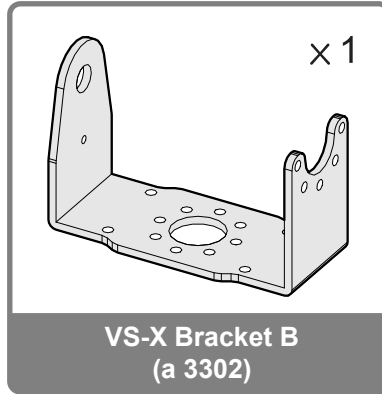
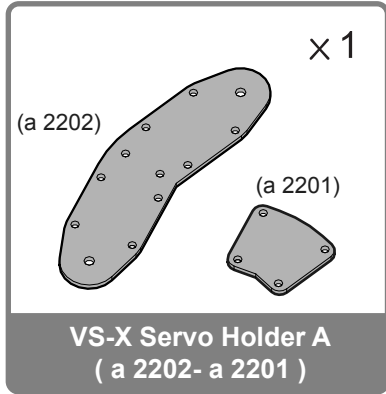

*This is not a VS-X bracket A.

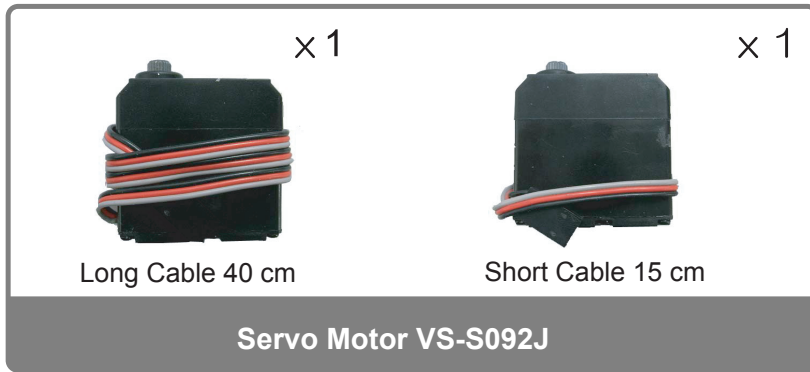

*Confusion of M2-4 and M2-5 screws may damage the robot.

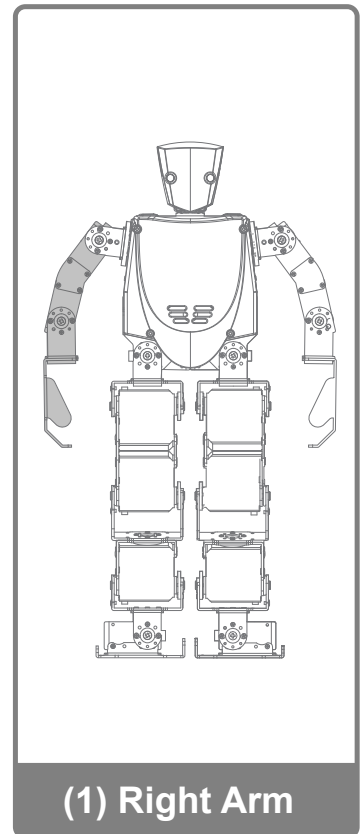
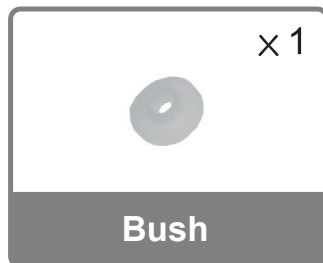
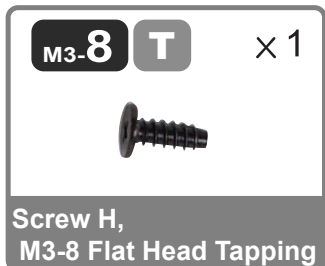

01. Assembling the Right Wrist

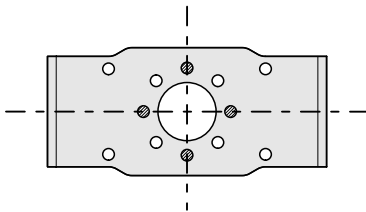
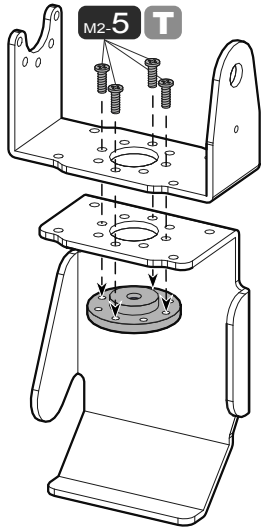

⊙ :Screwing spot

02. Assembling the Upper Right Arm

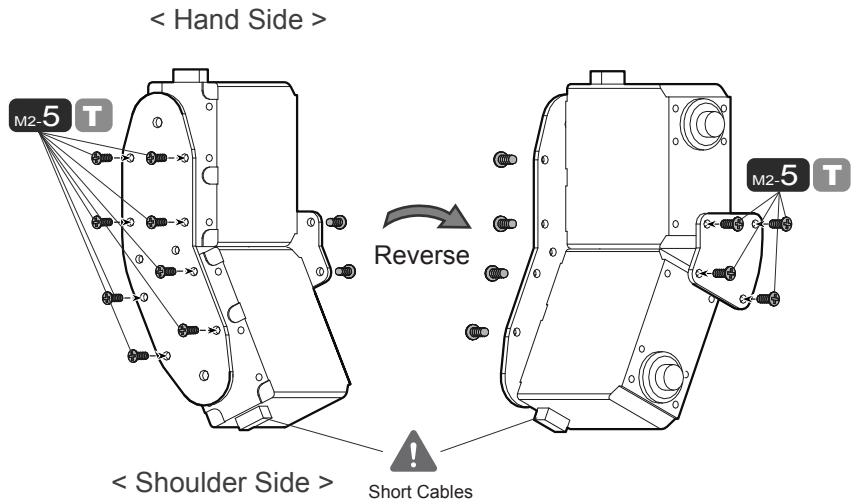

03. Mounting the Right Elbow Roll Axis

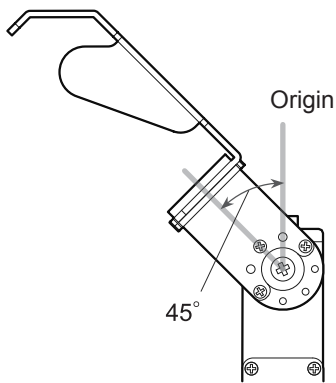
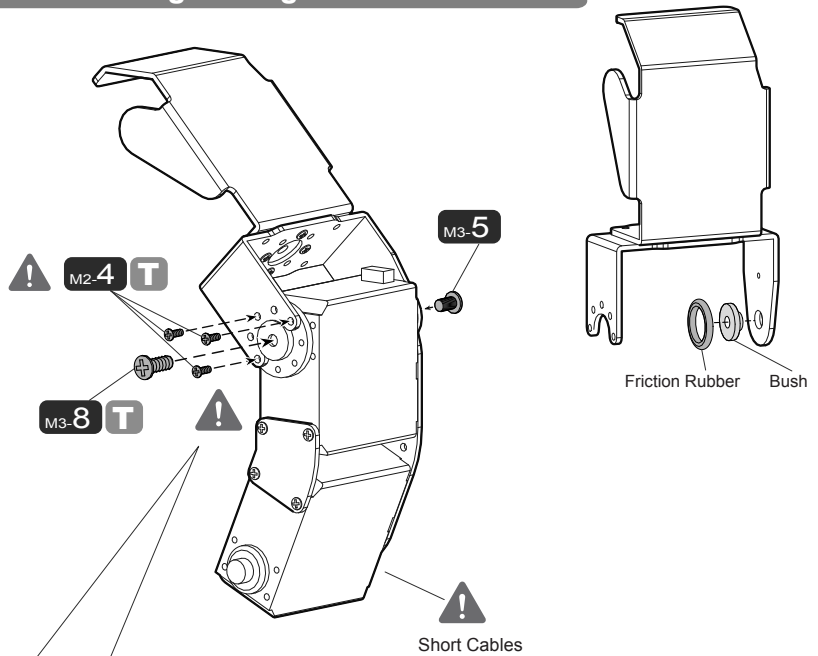

*Use the tapped holes as a reference.

< Frame Mounting Position against the Origin >

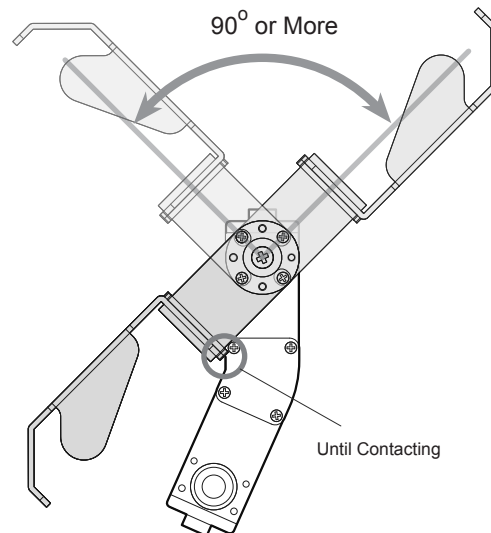

Checking the Movable Range

7-2 Assembling the Left Arm

Prepare the required parts.

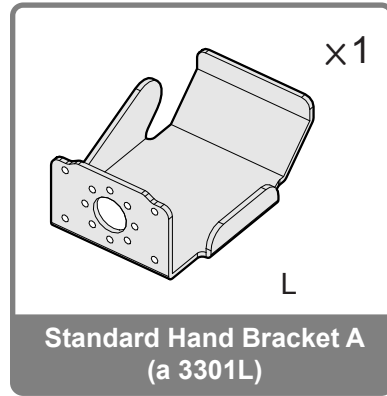
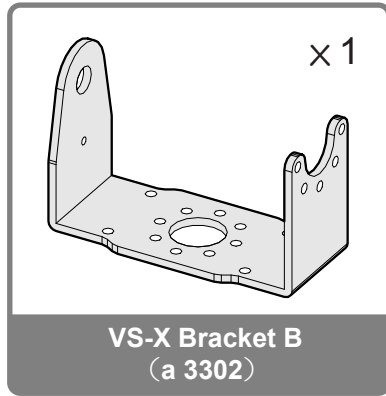
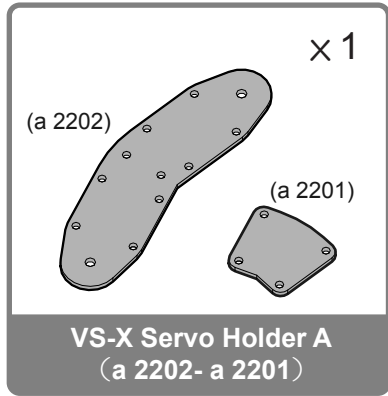

*This is not a VS-X bracket A.



*Confusion of M2-4 and M2-5 screws may damage the robot.

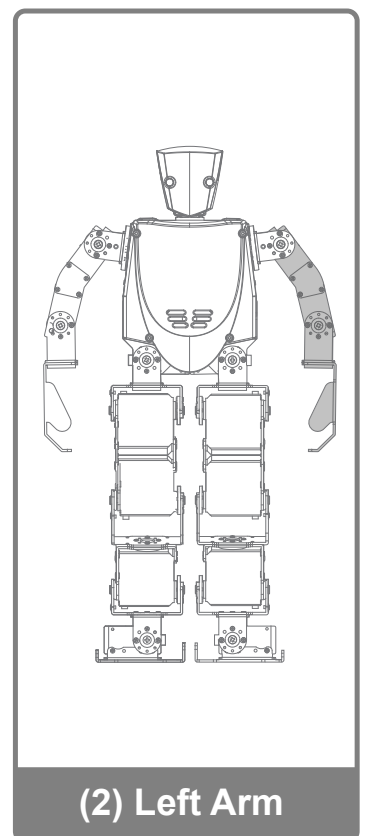
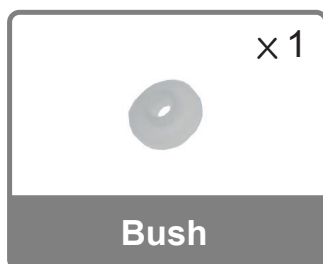
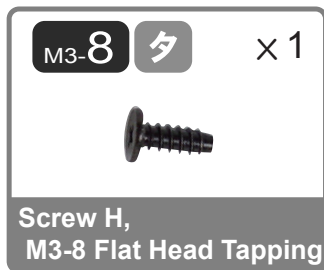
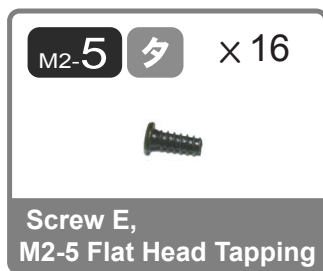
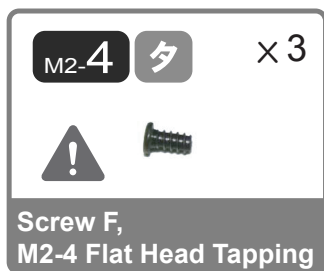

01. Assembling the Left Wrist

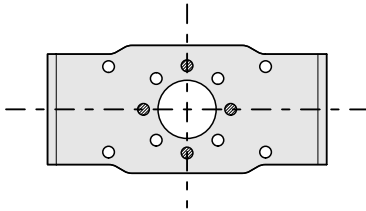
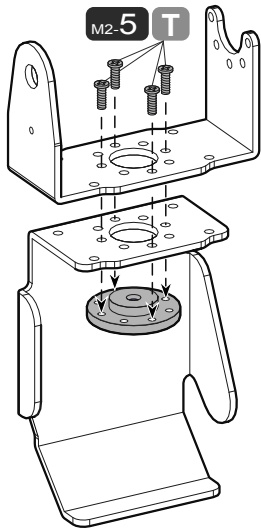

⊗ Screwing spot

02. Assembling the Upper Left Arm

<Hand Side>

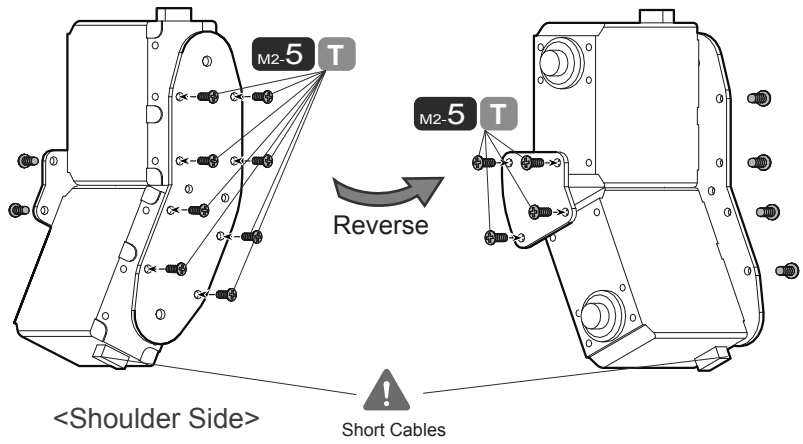

03. Mounting the Left Elbow Roll Axis

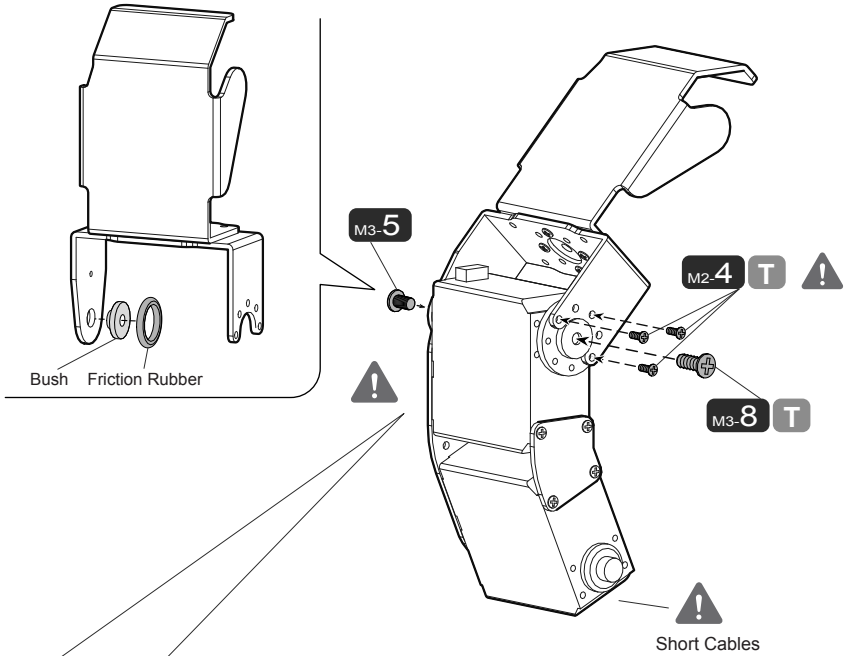

Origin

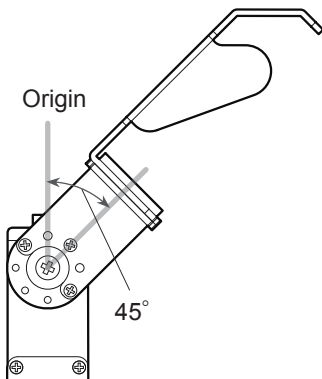

*Use the tapped holes as a reference.

<Frame Mounting Position against the Origin>

90° or More

Until Contacting

Checking the Movable Range

7-3 Assembling the Right Leg

Prepare the required parts.

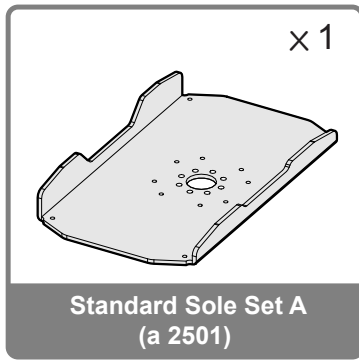
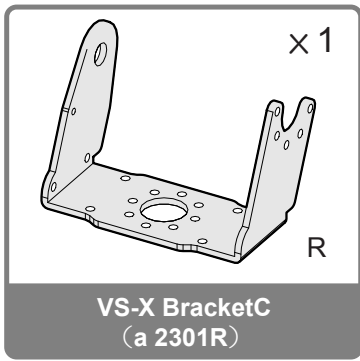
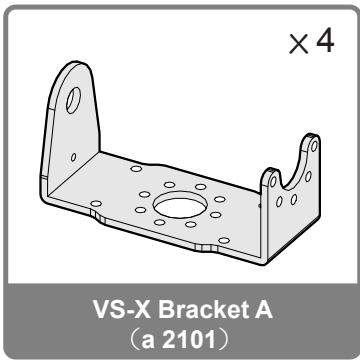

*This is not a VS-X bracket B.

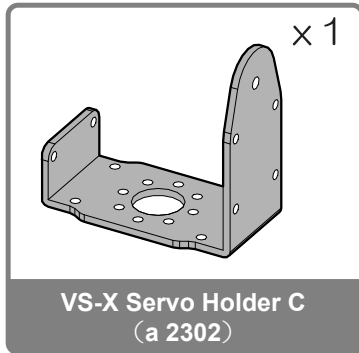
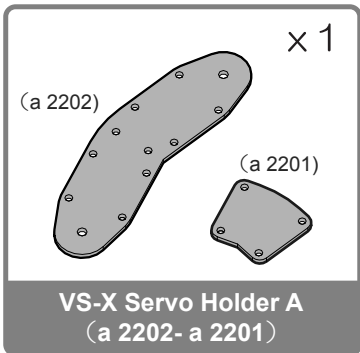

*Confusion of M2-4 and M2-5 screws may damage the robot.

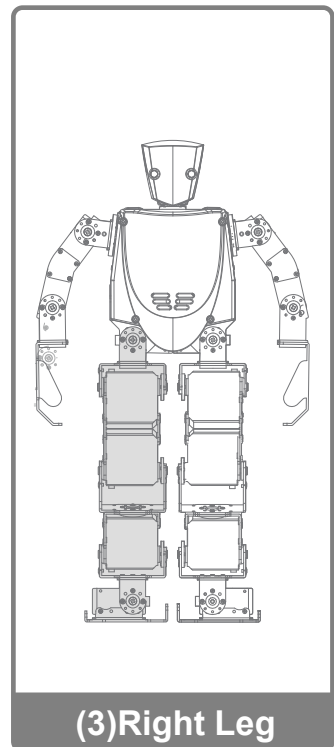
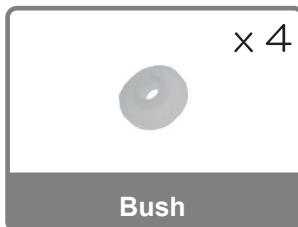
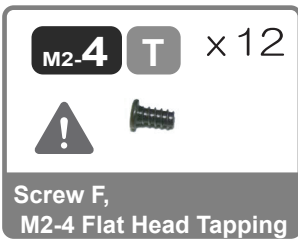

01. Assembling the Right Sole

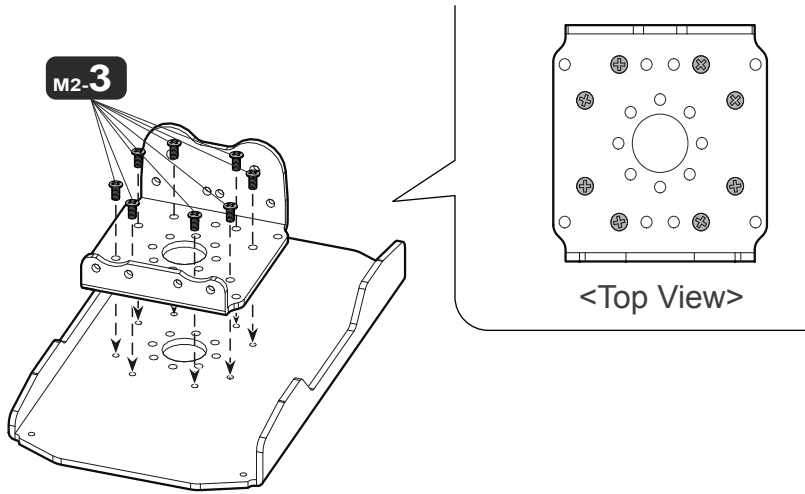

02. Mounting the Servo to the Right Sole

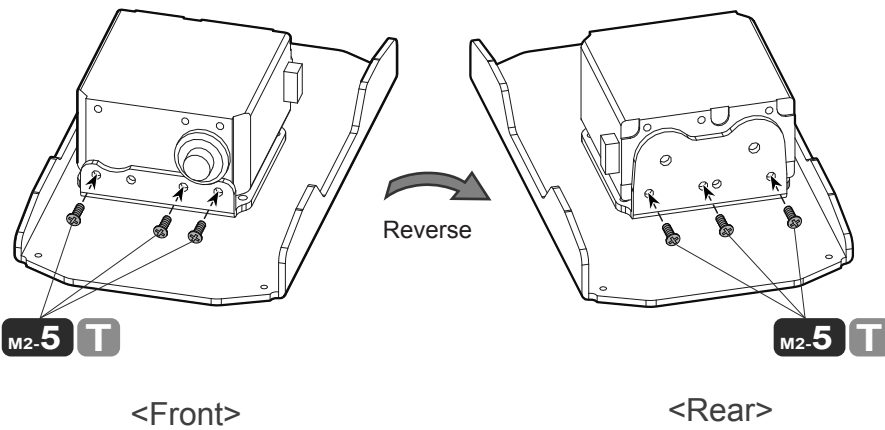

03. Assembling the Orthogonal Parts

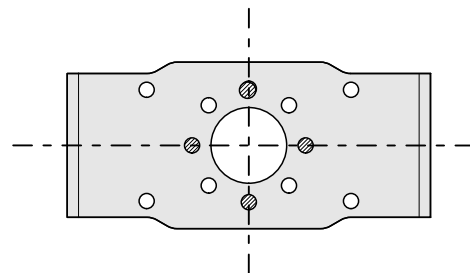
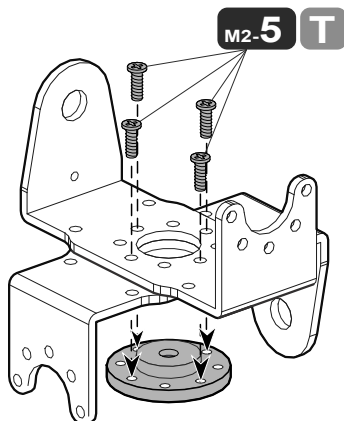

● : Screwing spot

⚠ Pay attention to the assembling direction.

04. Mounting the Right Ankle Roll Axis

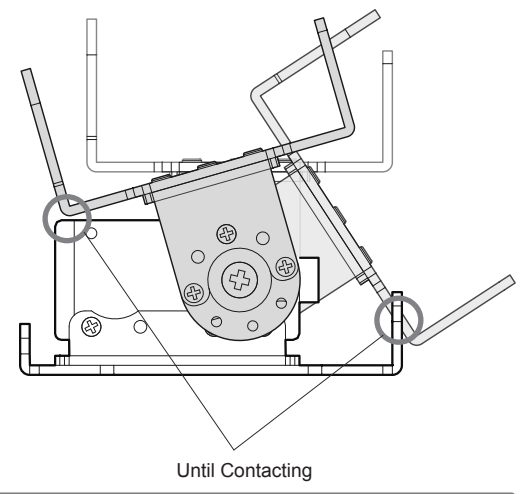
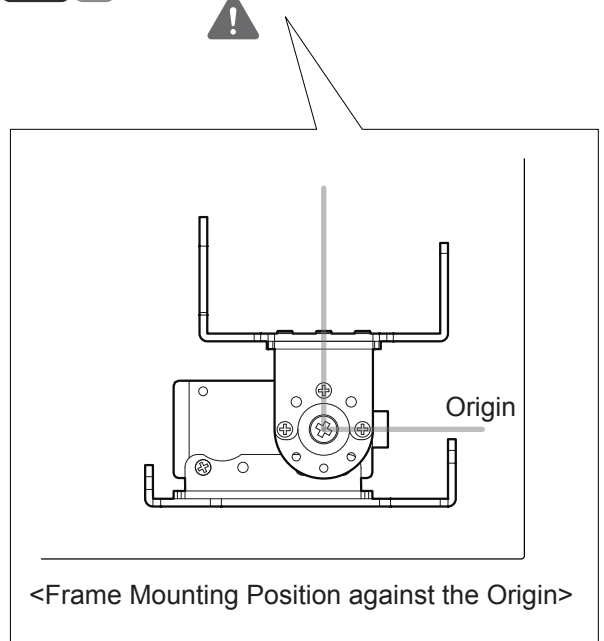
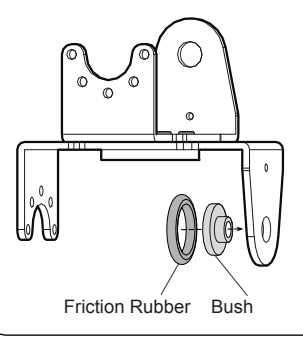
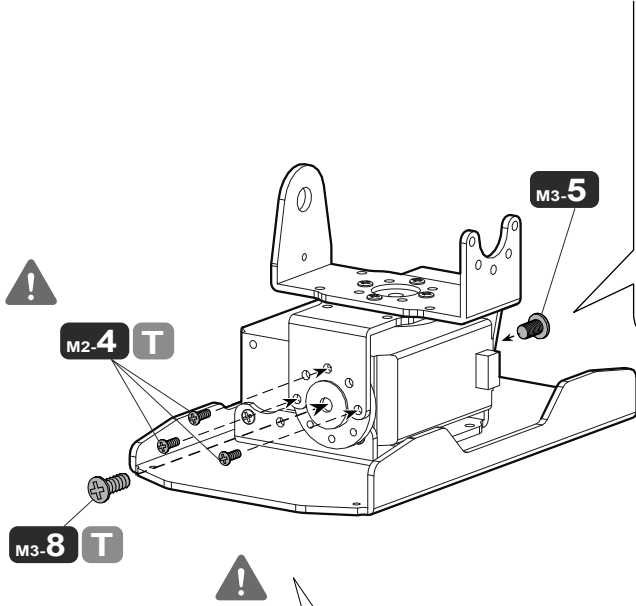

Checking the Movable Range

05. Assembling the Right Below Knee Parts - 1

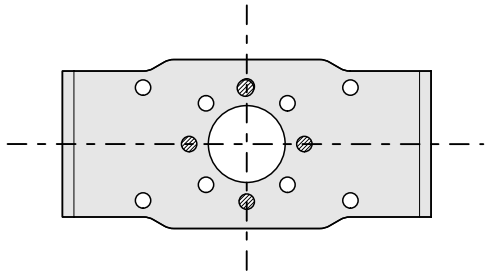
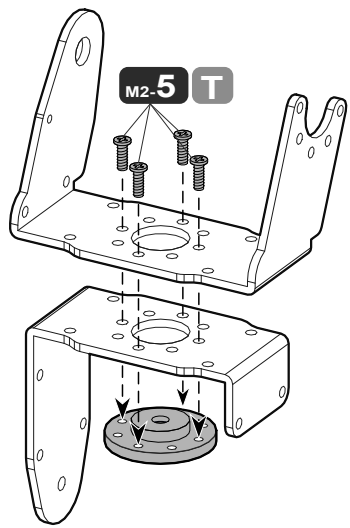

● : Screwing spot

06. Assembling the Right Below Knee Parts - 2

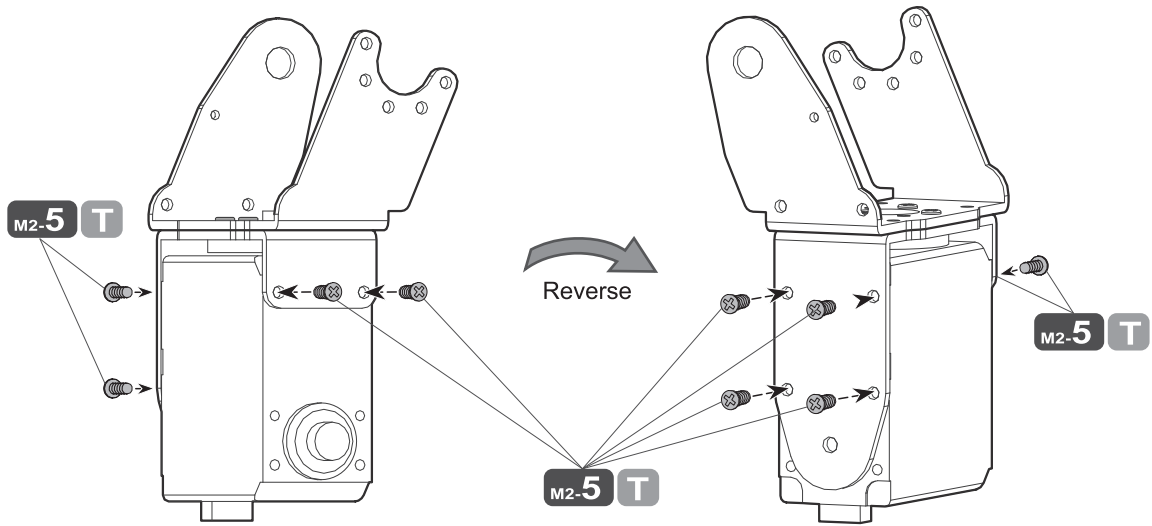

07. Mounting the Right Ankle Pitch Axis

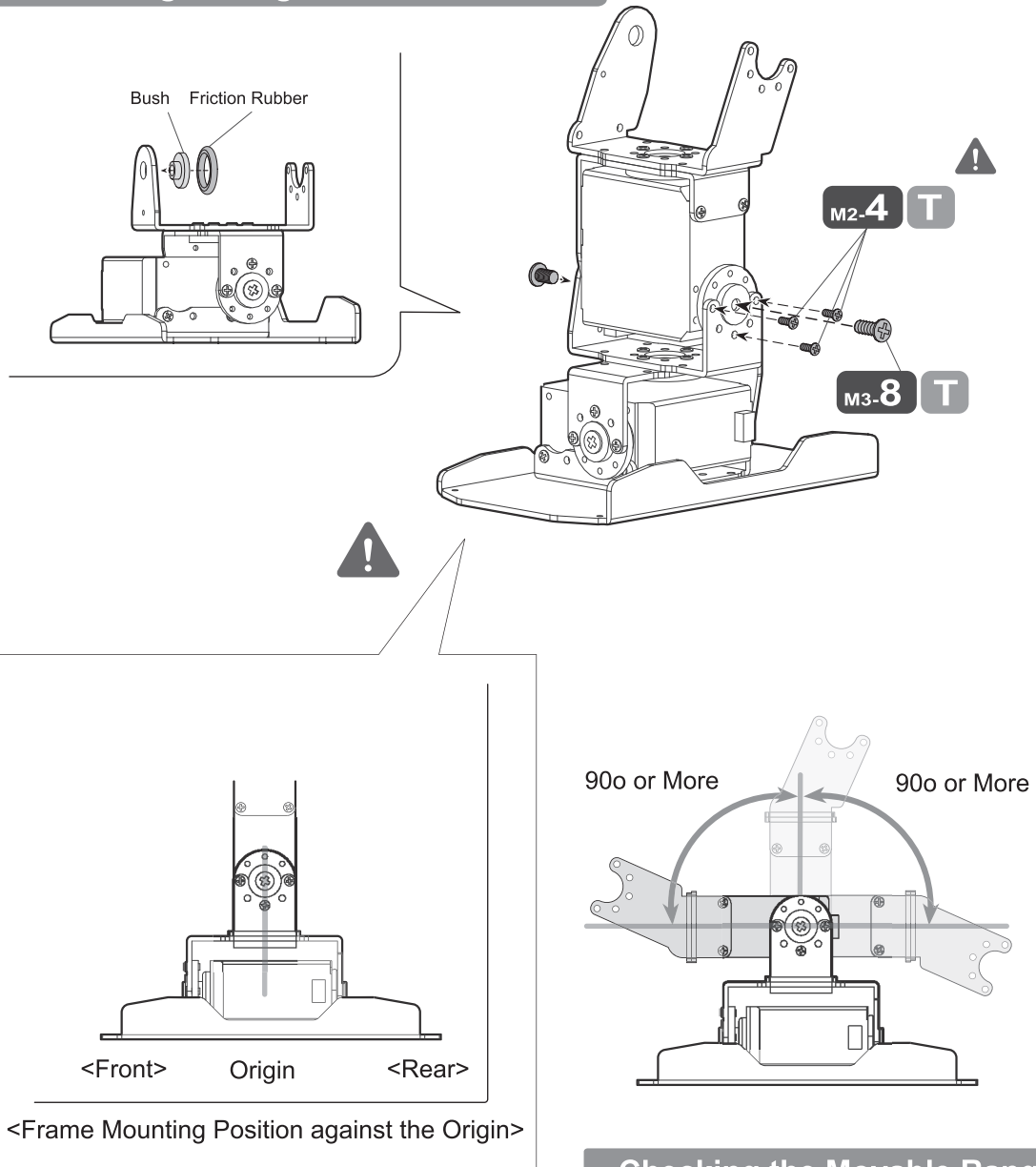

08. Assembling the Right Thigh

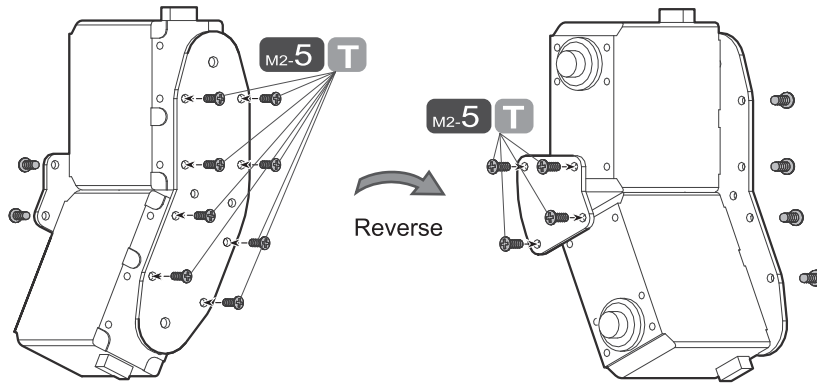

09. Mounting the Right Below Knee Pitch Axis

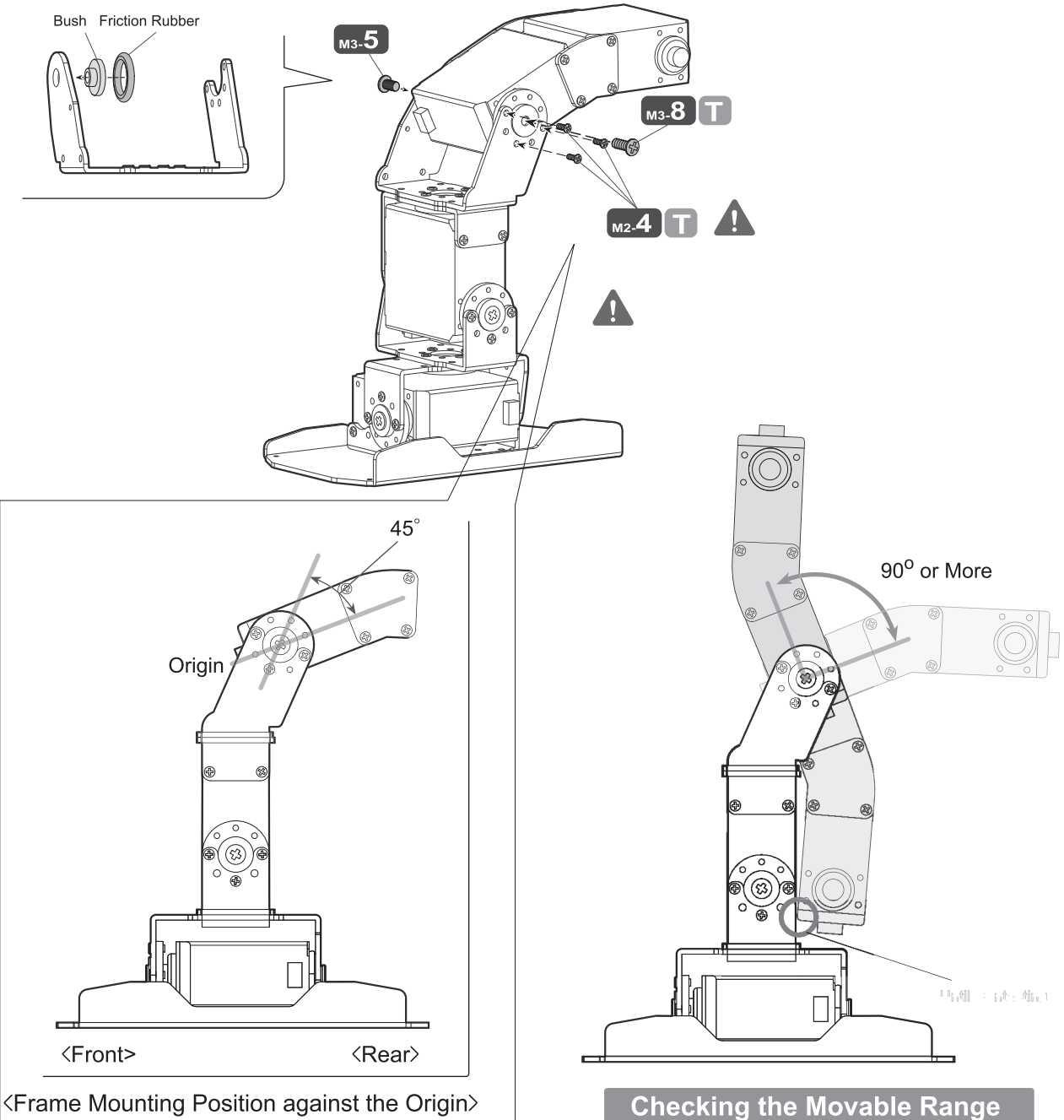

10. Assembling the Orthogonal Parts

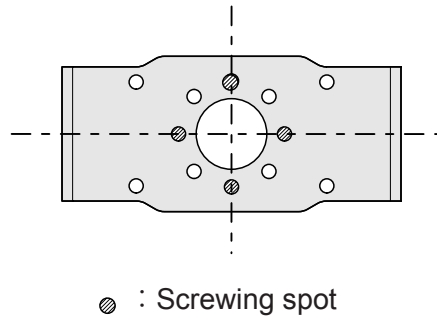
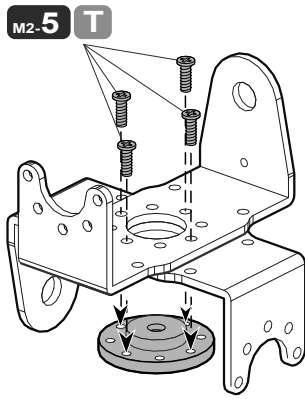

⚠ Pay attention to the assembling direction.

11. Assembling the Right Th

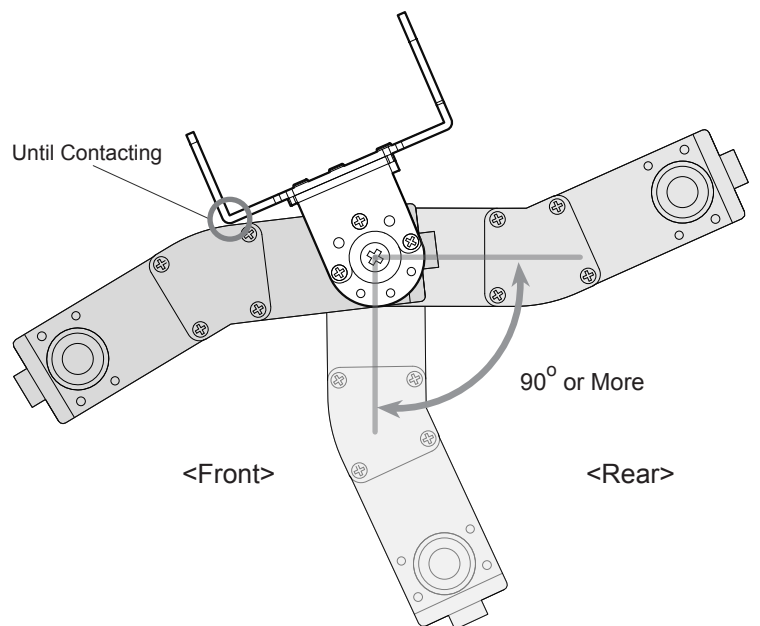
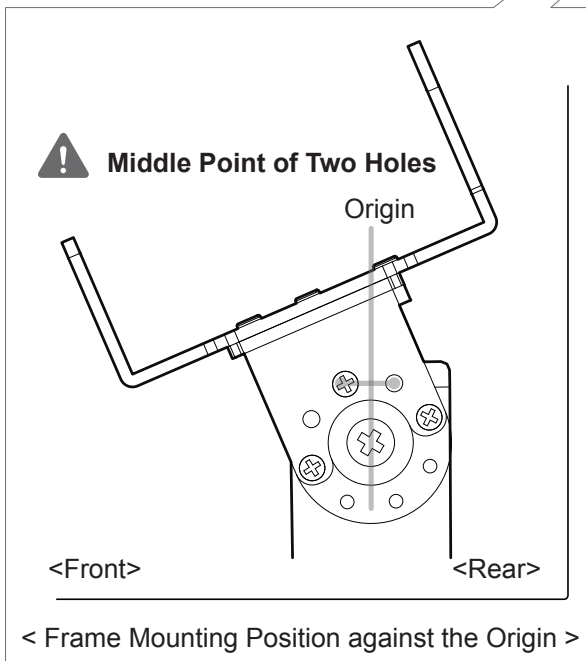
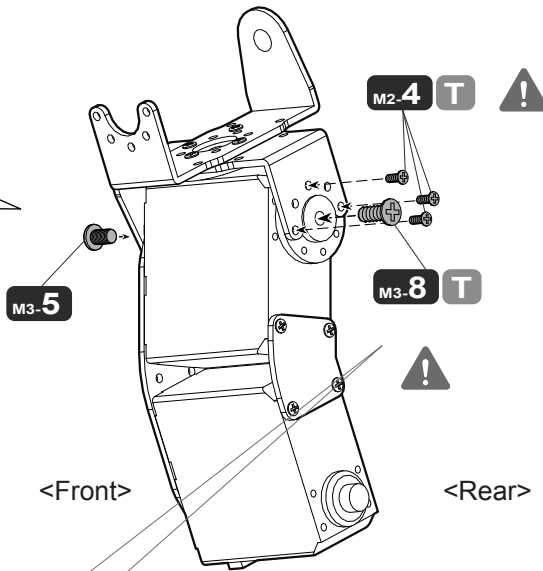
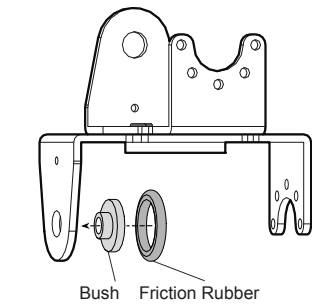

Checking the Movable Range

7-4 Assembling the Left Leg

Prepare the required parts.

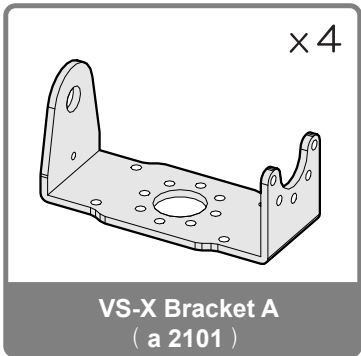

*This is not a VS-X bracket B.

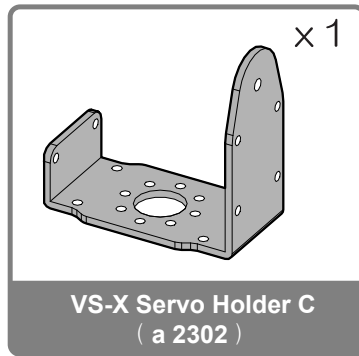
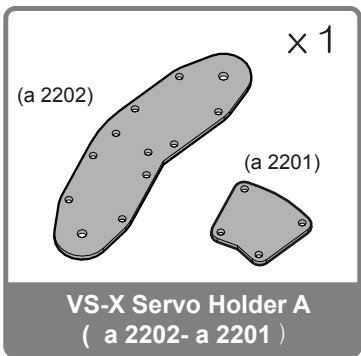
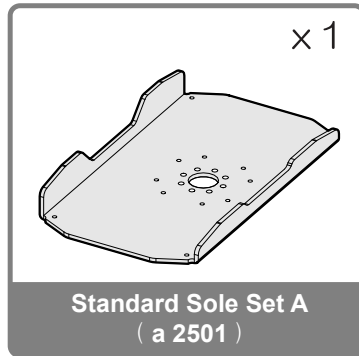
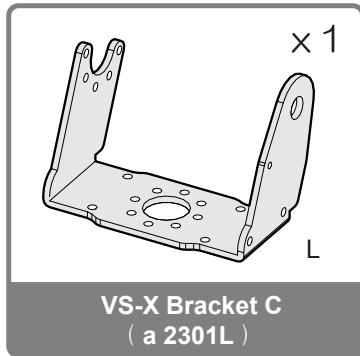

*Confusion of M2-4 and M2-5 screws may damage the robot.

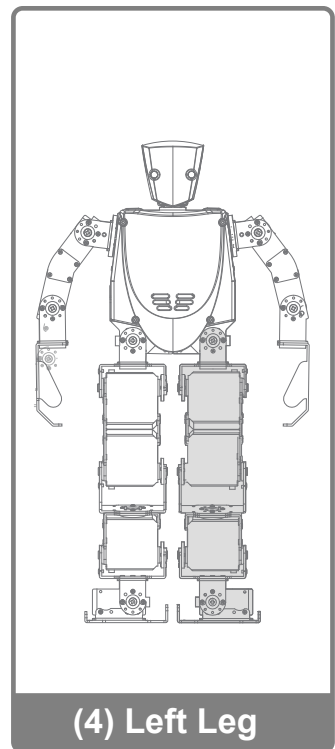
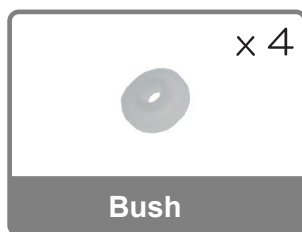
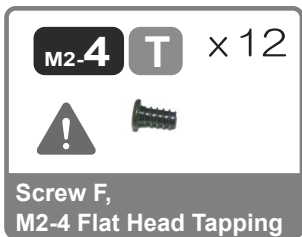
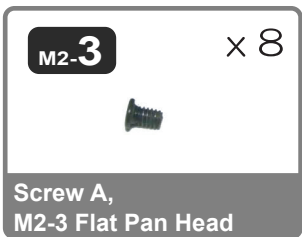

01. Assembling the Left Sole

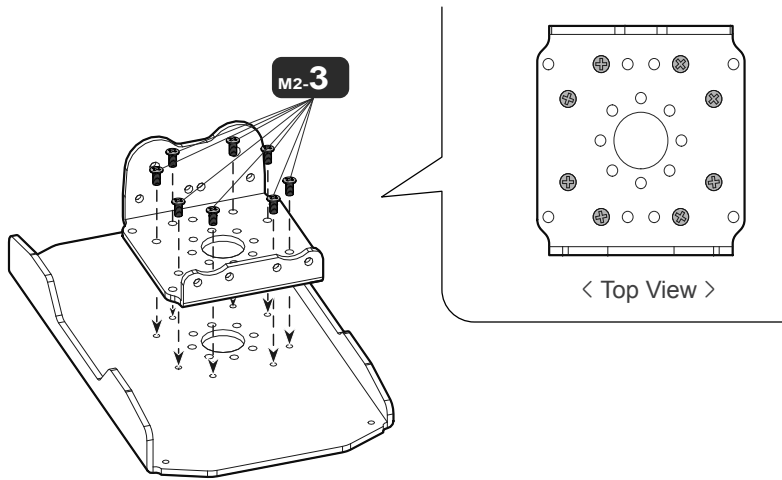

02. Mounting the Servo to the Left Sole

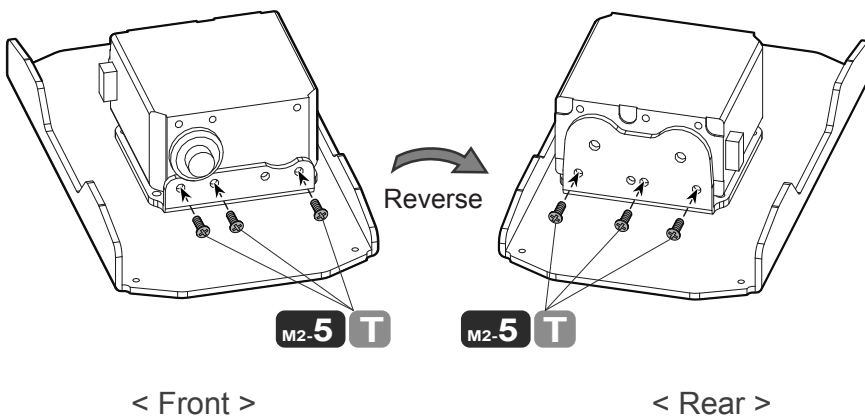

03. Assembling the Orthogonal Parts

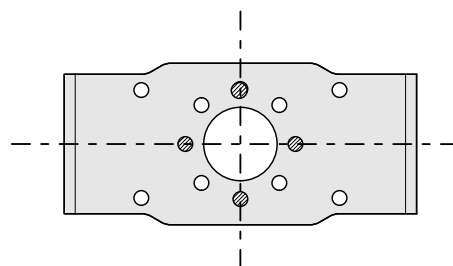
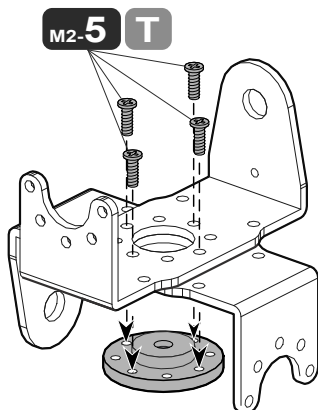

● : Screwing spot

! Pay attention to the assembling direction.

04. Mounting the Left Ankle Roll Axis

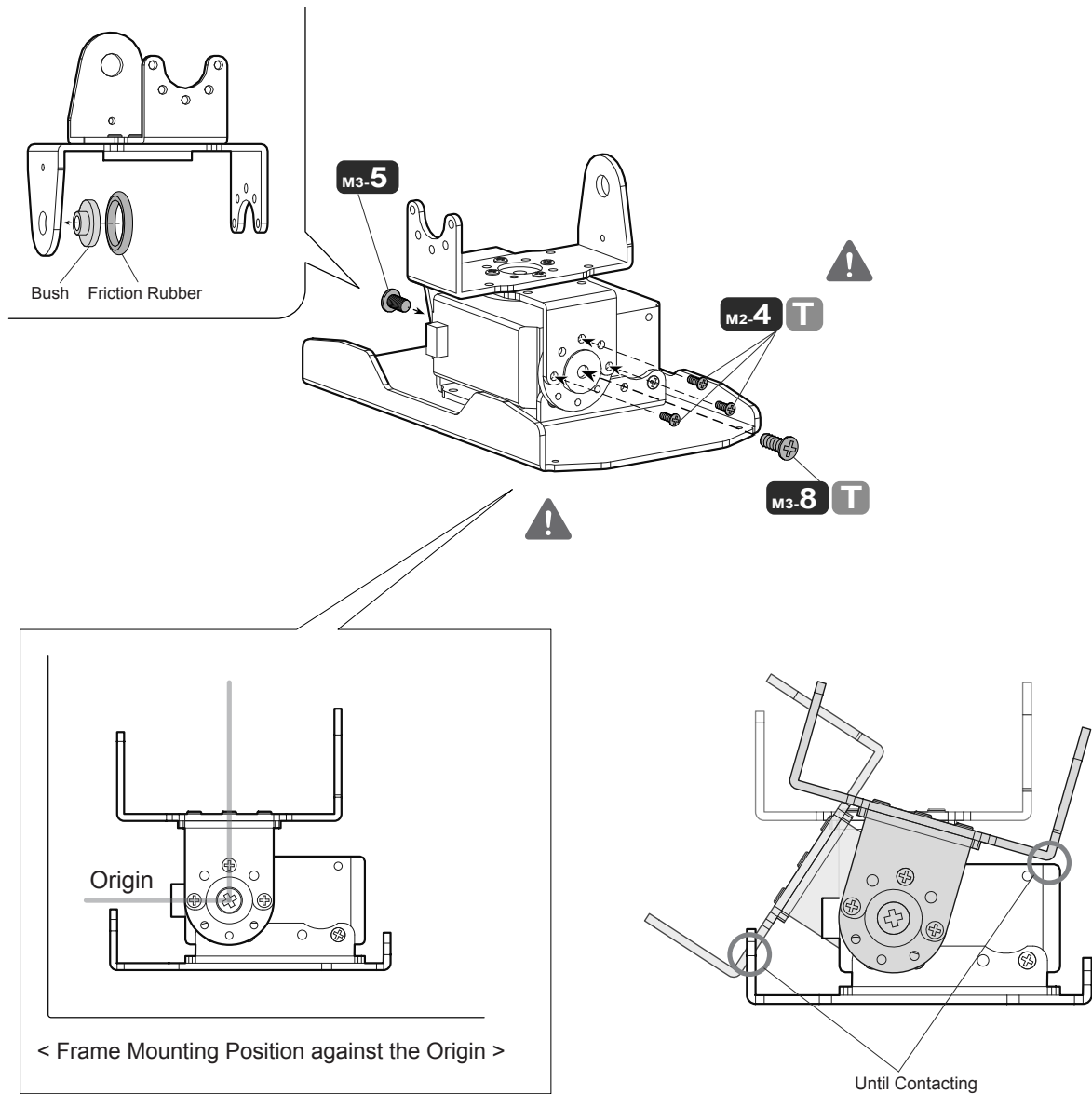

Checking the Movable Range

05. Assembling the Left Below Knee Parts - 1

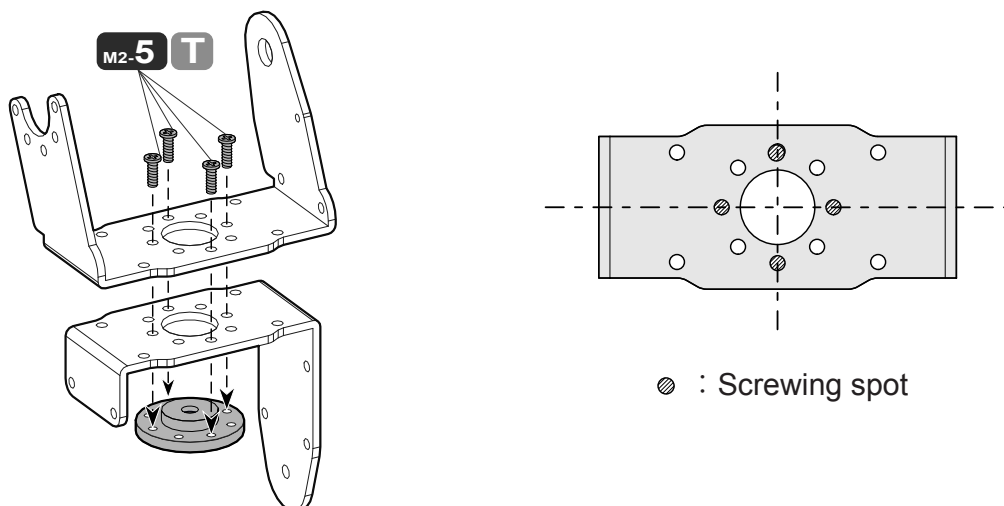

06. Assembling the Left Below Knee Parts - 2

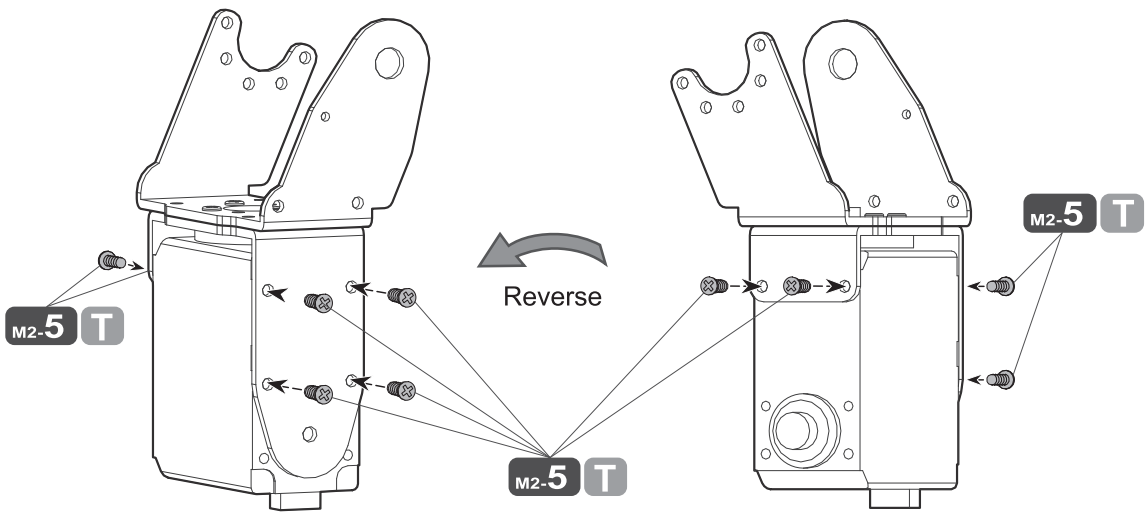

07. Mounting the Left Ankle Pitch Axis

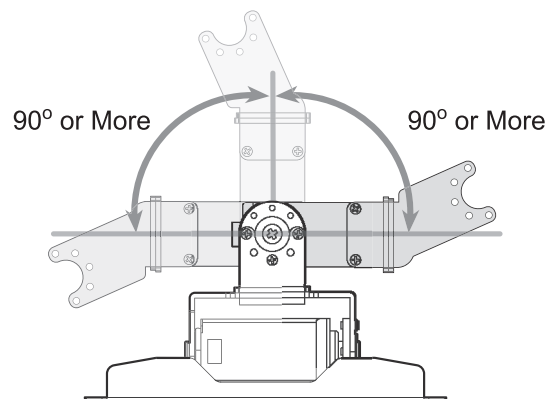
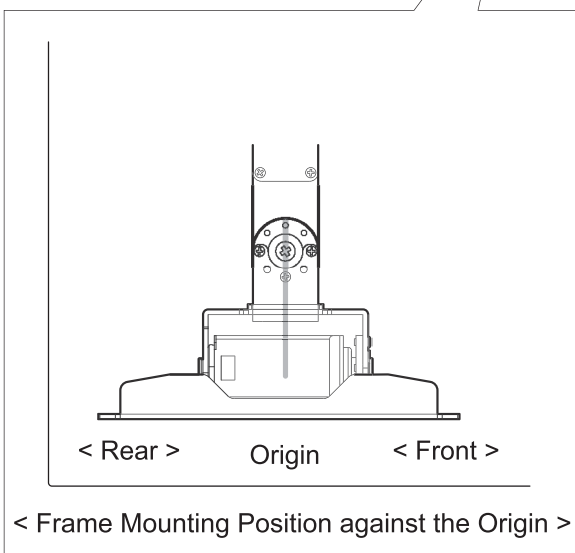
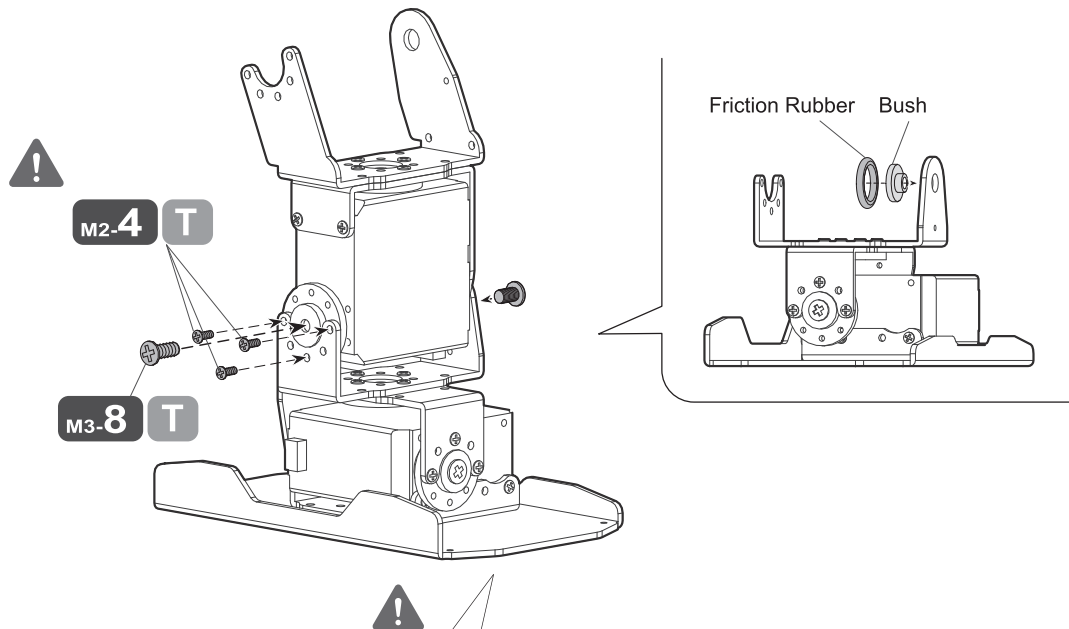

Checking the Movable Range

08. Assembling the Left Thigh

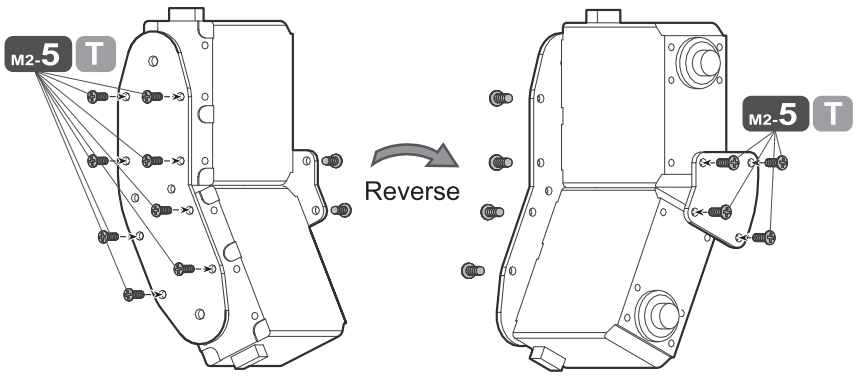

09. Mounting the Left Below Knee Pitch Axis

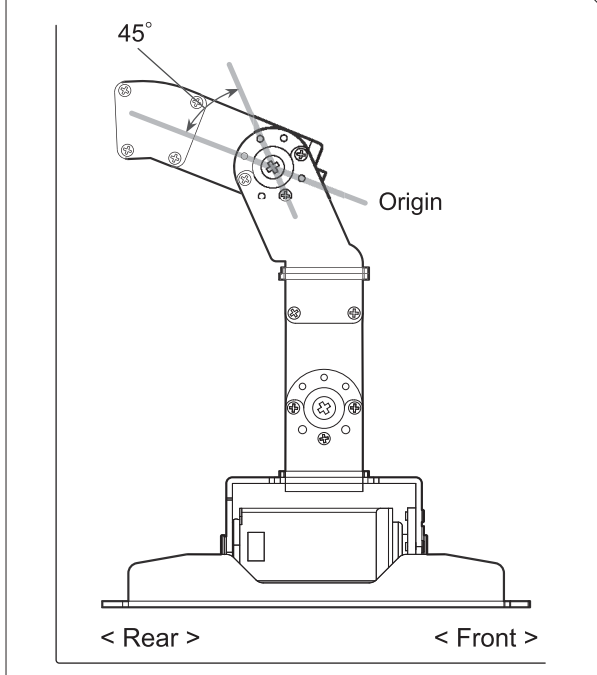
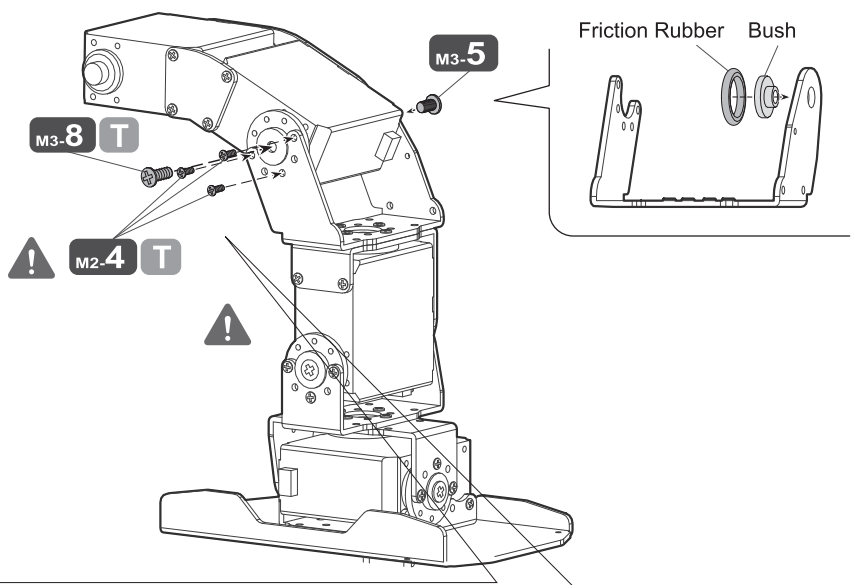

< Frame Mounting Position against the Origin >

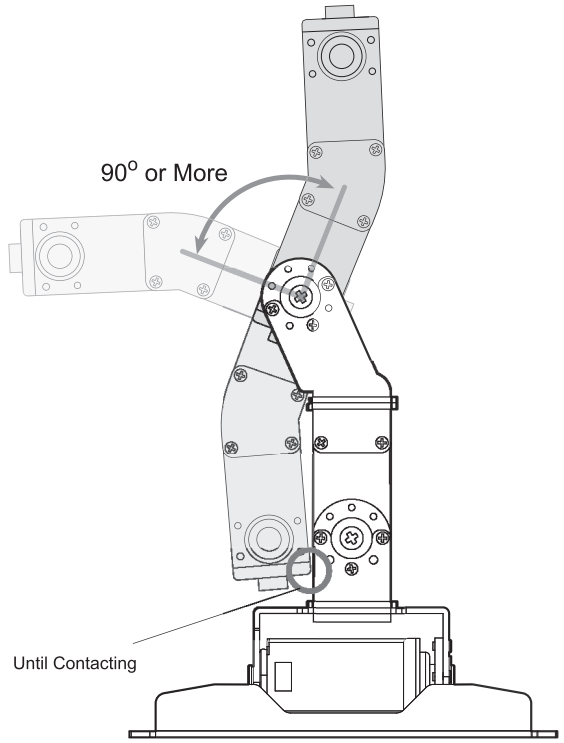

Checking the Movable Range

10. Assembling the Orthogonal Parts

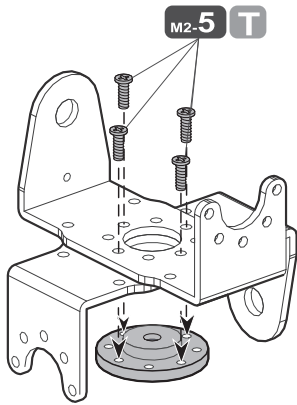

! Pay attention to the assembling direction.

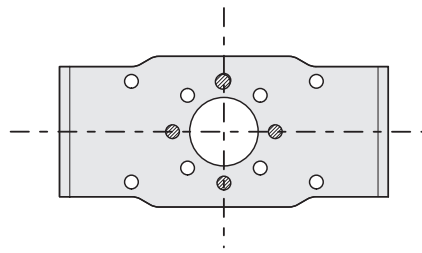

☉ : Screwing spot

11. Assembling the Left Thigh Pitch Axis

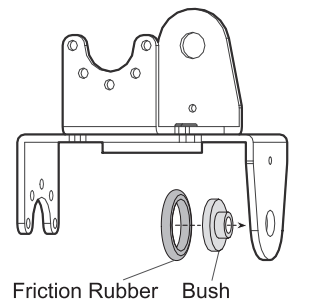
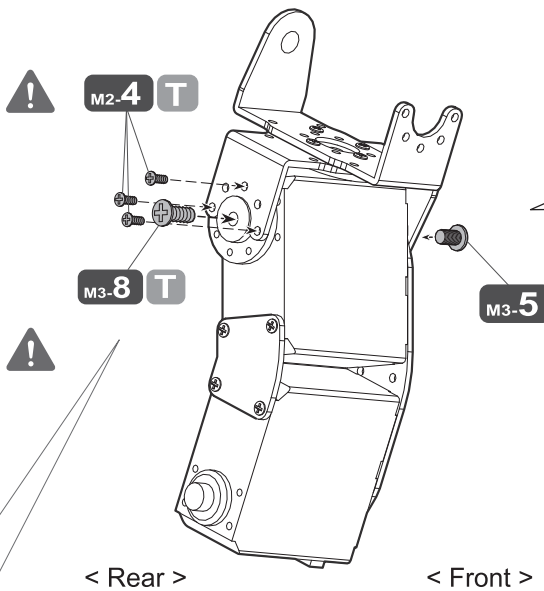

Friction Rubber Bush

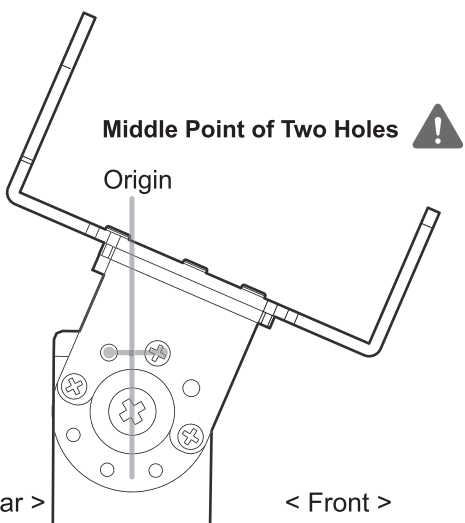

< Frame Mounting Position against the Origin >

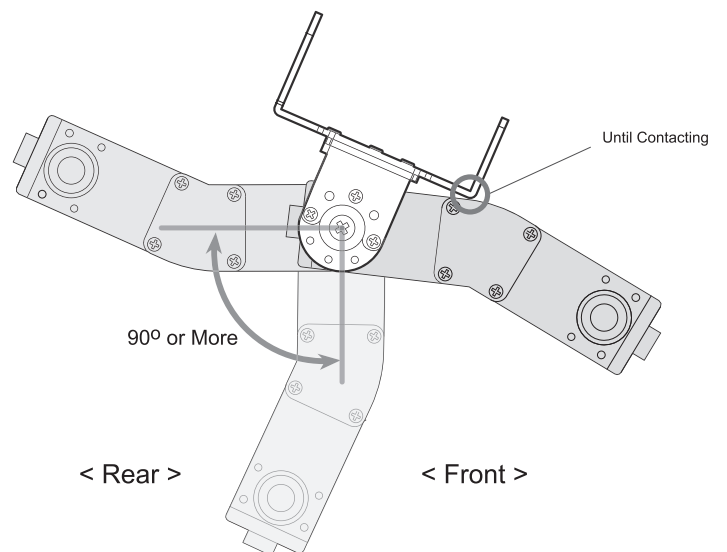

Checking the Movable Range

7-5 Assembling the Body

Prepare the required parts.

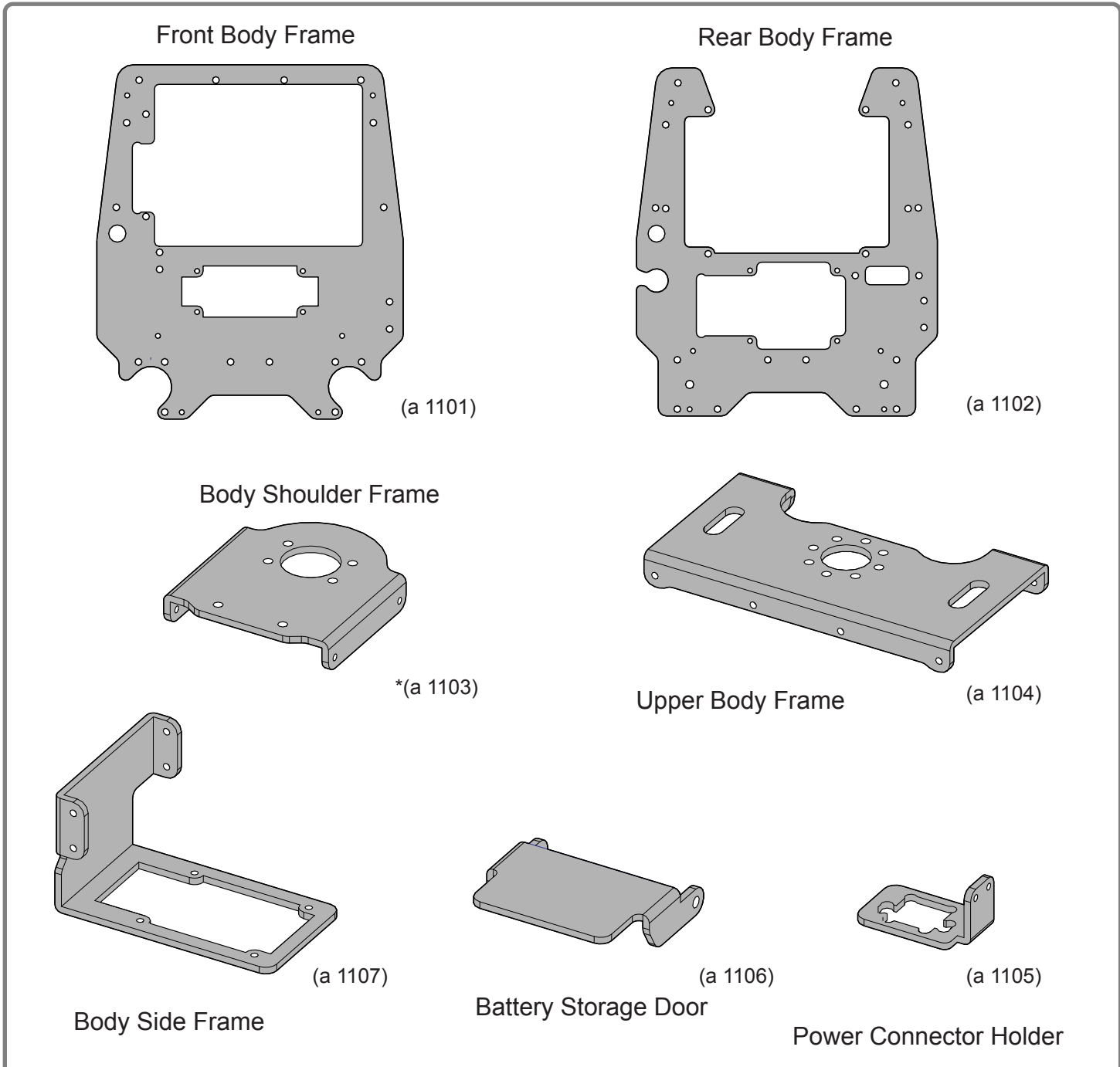

VS-X Standard Body Set

 x0
 x5
Servo Motor VS-S092J □

 x1
Servo Horn

One Each
 *(a 1103) x 2
 (To Be Continued)

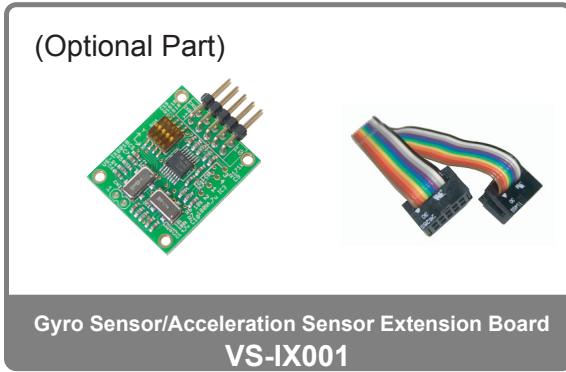
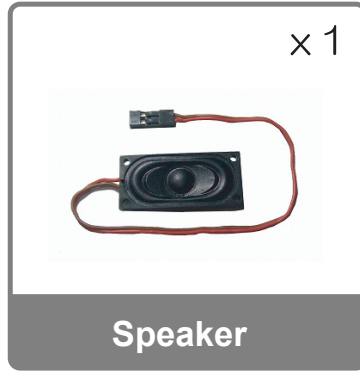
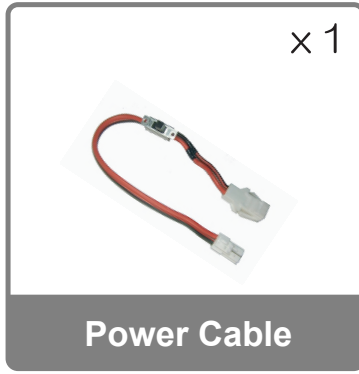
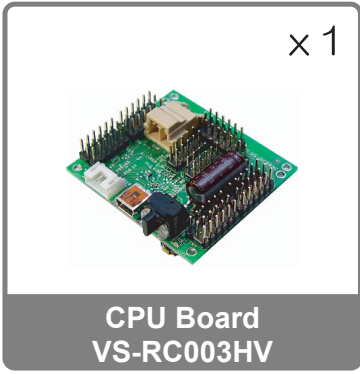

*Confusion of M2-4 and M2-5 screws may damage the robot.

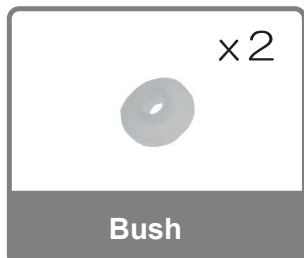
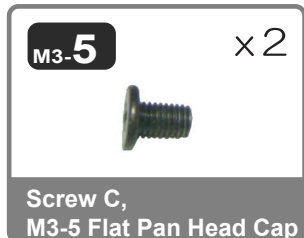
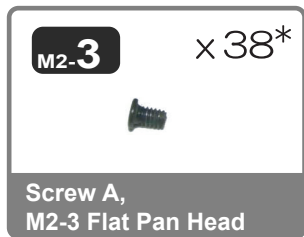

*Four of them are for the optional part.

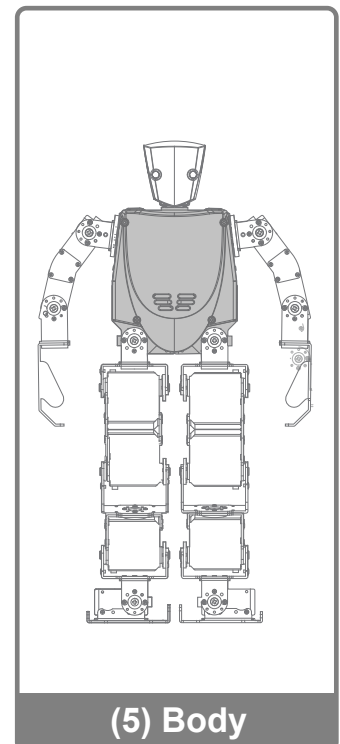

(Continued from Previous page)

01. Assembling the Upper Body

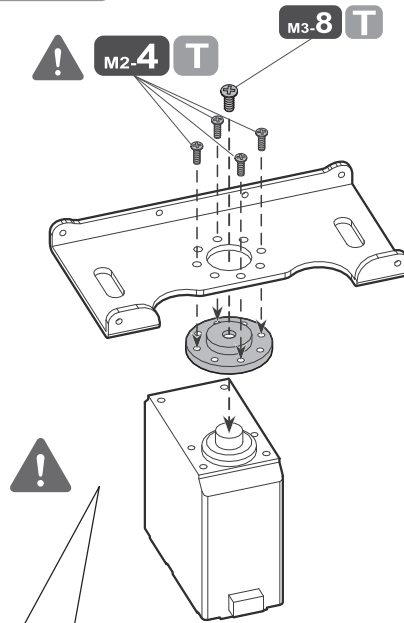

< Front >

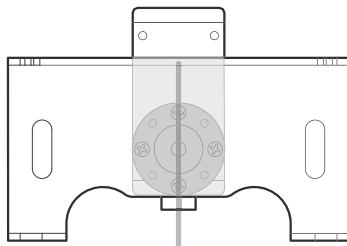

< Rear >

Origin

< Mounting Position against the Origin >

90° or More

90° or More

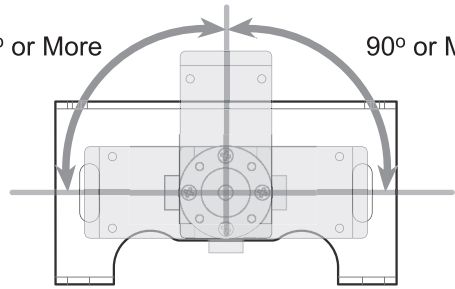

Checking the Movable Range

02. Mounting the Thigh Roll Axis

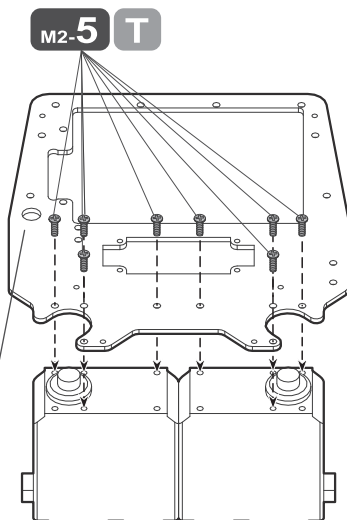

! Be careful not to confuse the front and back of the frame. Mount the frame so that this hole will be located on the right side of the robot.

03. Mounting the Upper Body

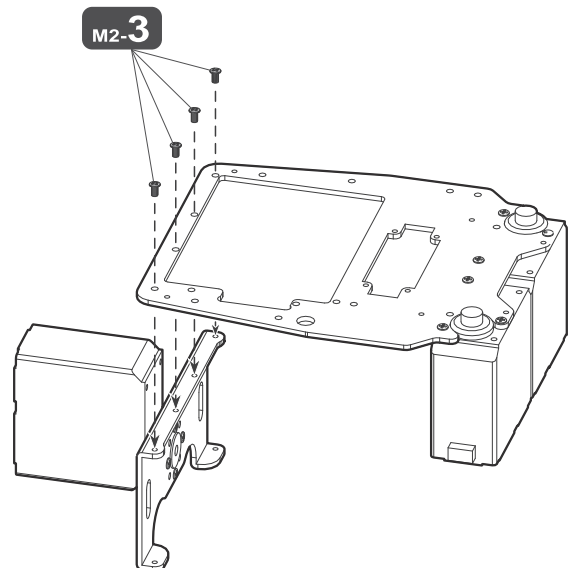

04. Mounting the Power Connector Holder

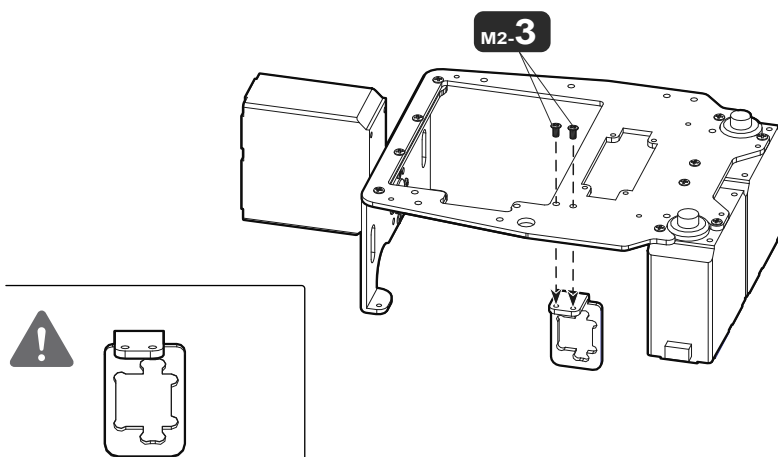

<Pay attention to the mounting direction.>

05. Mounting the Game Pad Conversion Connector

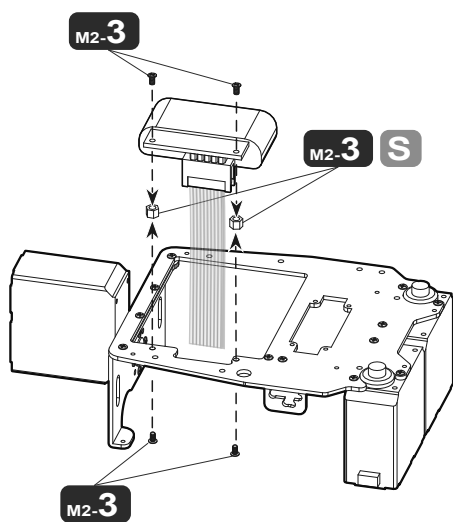

10-Core Connector Mounting Position

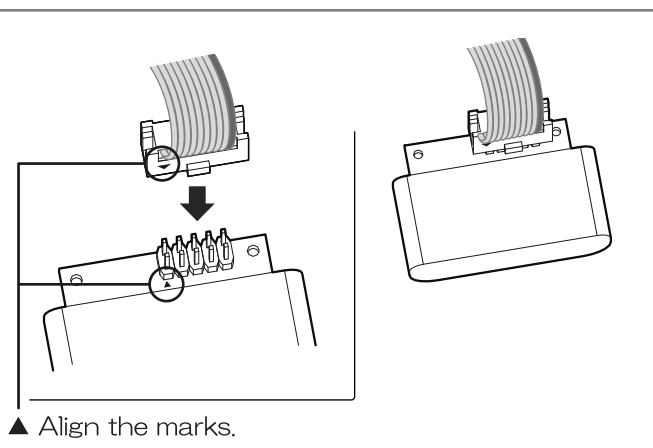

06. Assembling the Shoulder

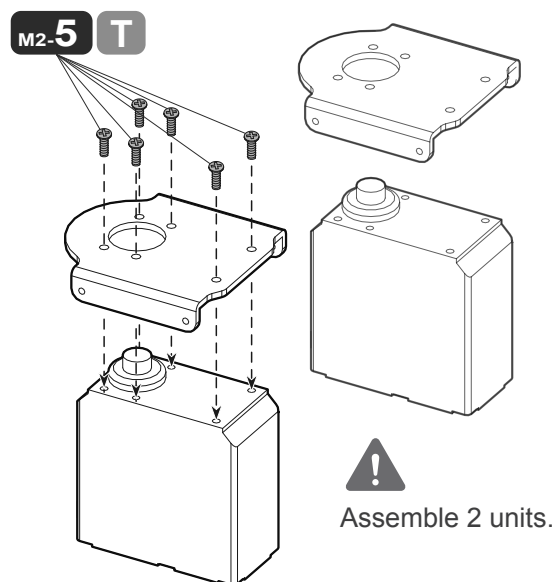

07. Assembling the Shoulder

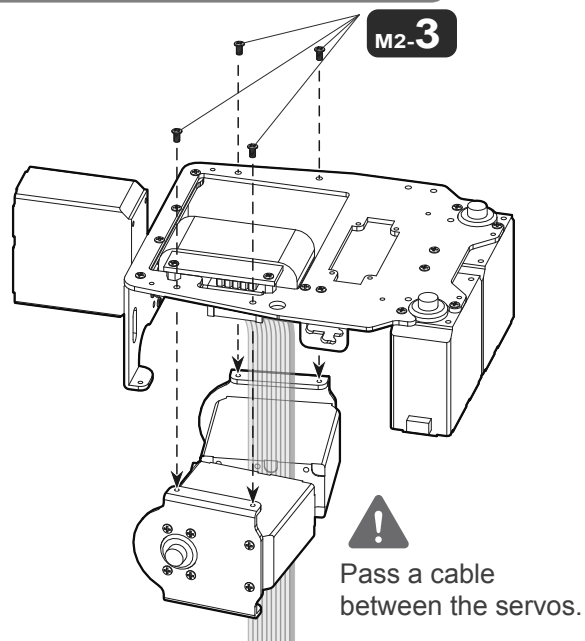

08. Mounting the Speaker

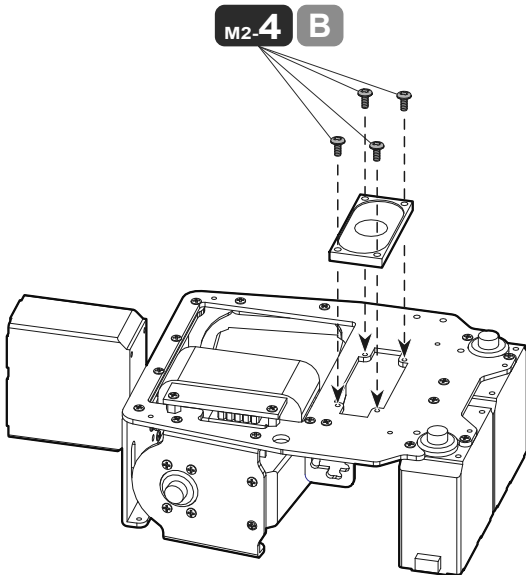

Mounting the Gyro Sensor (Optional)

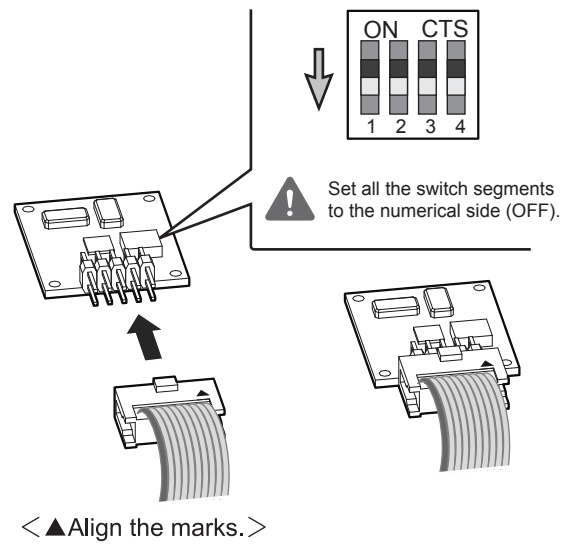

09. Mounting the Body Side Frame

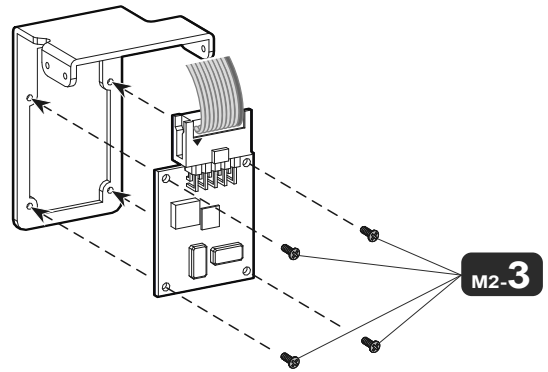
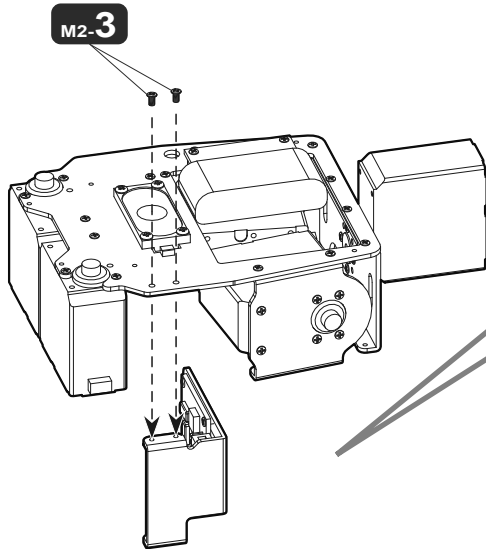

(Optional Part)

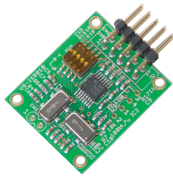

The robot automatically balances itself to prevent tumbling.

*When you purchase the Product alone
Prepare an IXBUS connection cable at the length of 12 cm.
For both connectors, align a brown cable with "▲" and crimp them
so that the cable will be located on the "▲" mark side.
For details, see Reference Material
"IXBUS Connection Cable Preparation Manual.pdf."

Gyro Sensor/Acceleration Sensor Extension Board
VS-IX001

10. Mounting the Spacer to the CPU

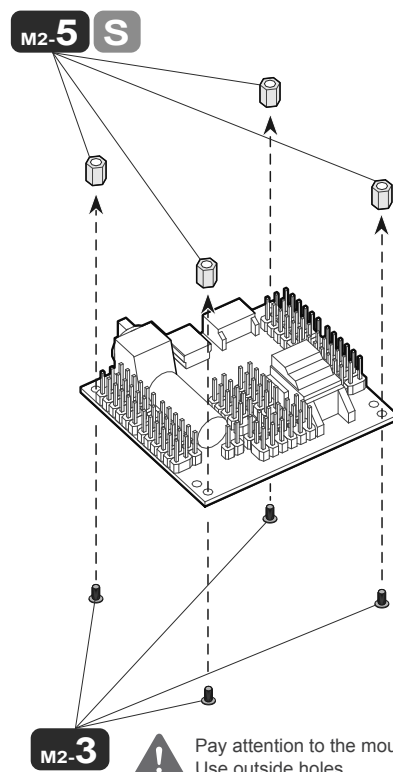

11. Connecting the Power Cable

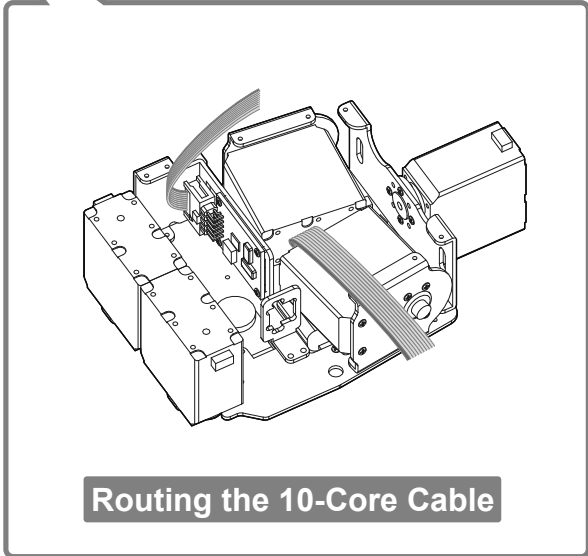
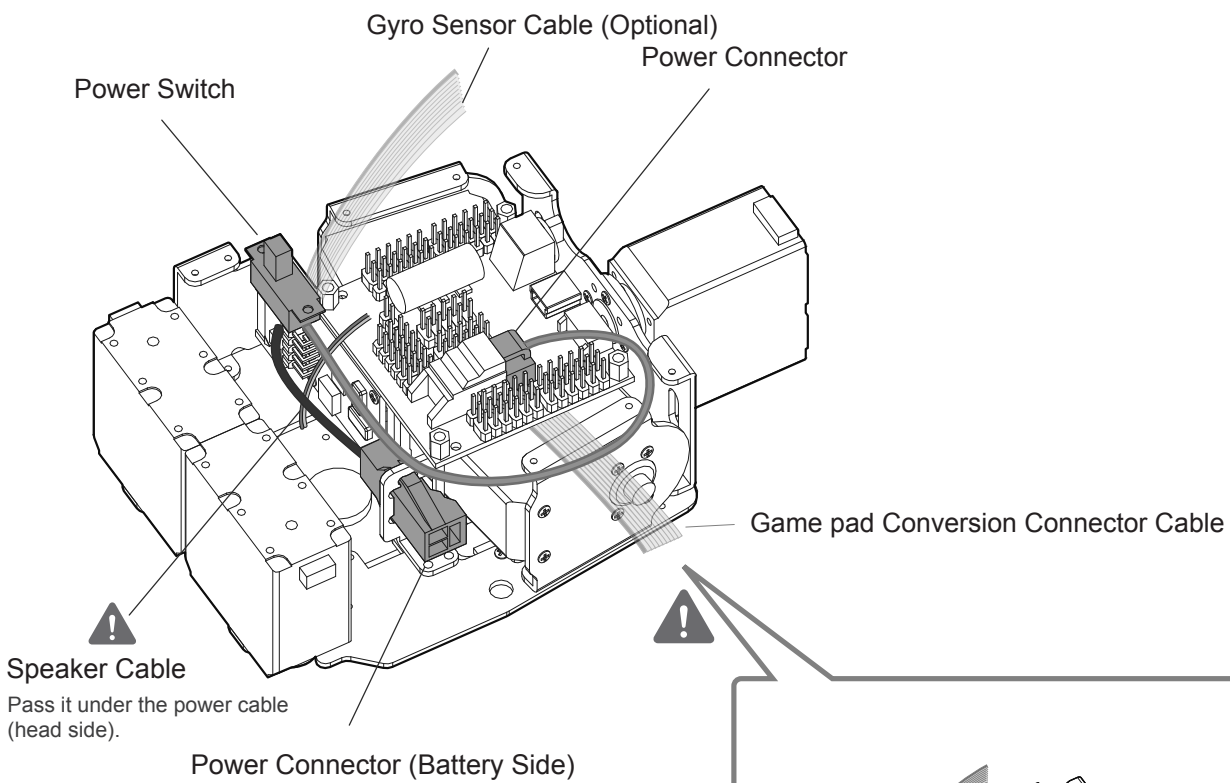

12. Mounting the Switch

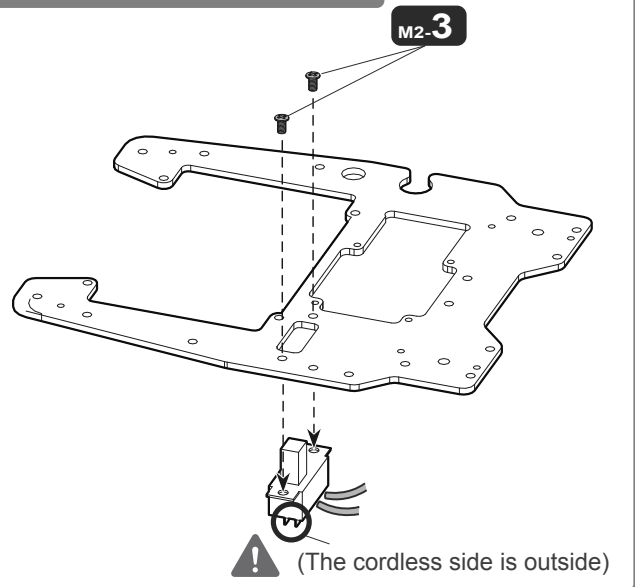

13. Mounting the CPU

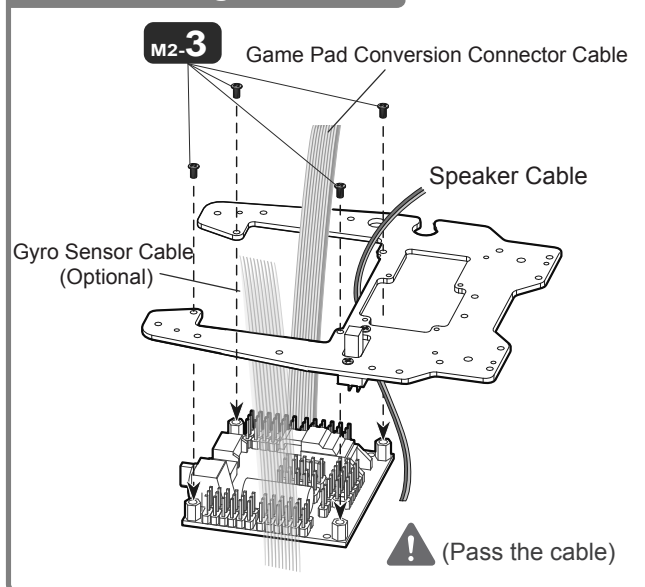

14. Mounting the Rear Frame

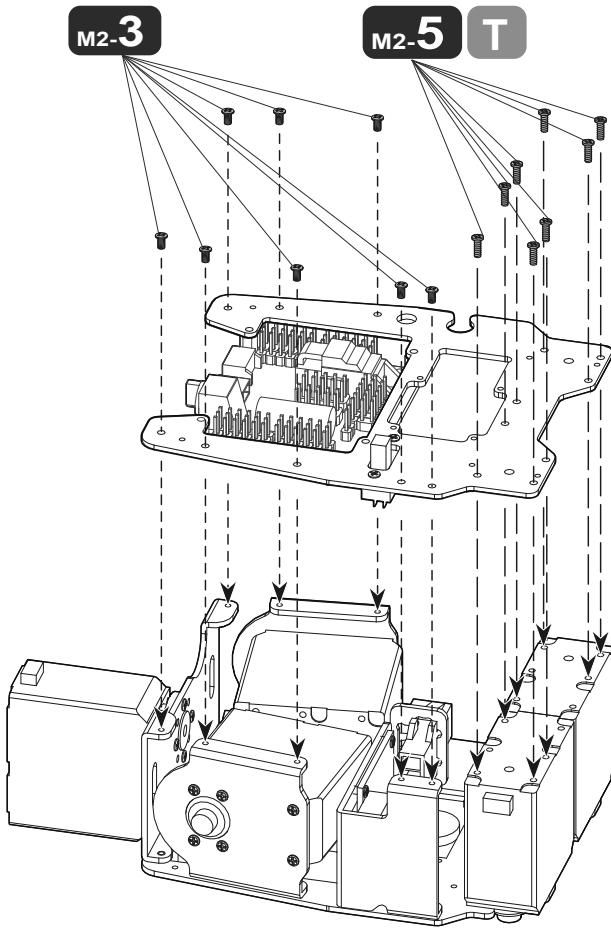

Lead out shoulder pitch axis cables from the top and thigh roll axis cables from the bottom.

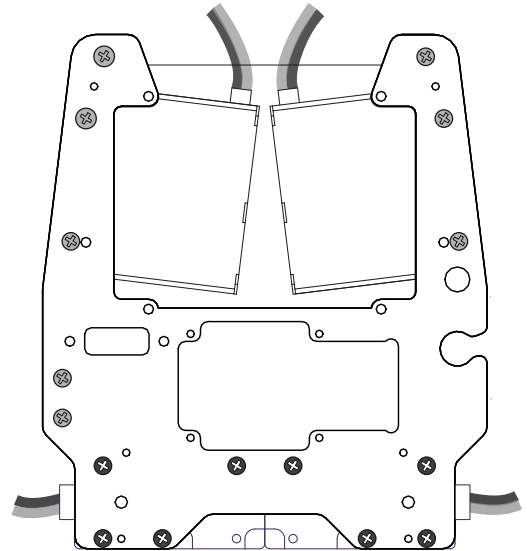

Ensure that the power cable is not caught between the CPU and the servo motor.

< Top View >

15. Mounting the Battery Storage Door

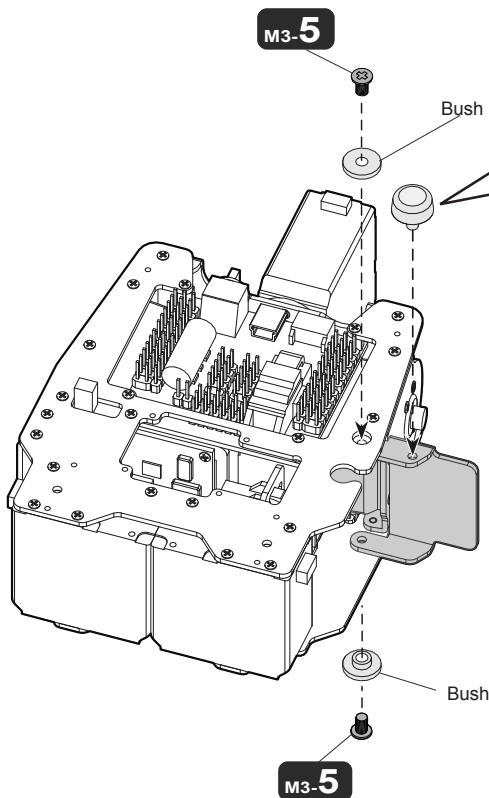

Secure firmly with cutting pliers so that it will not come off.



Urea Resin Screw



Nut for Urea Resin Screw



The grooved side is upward.

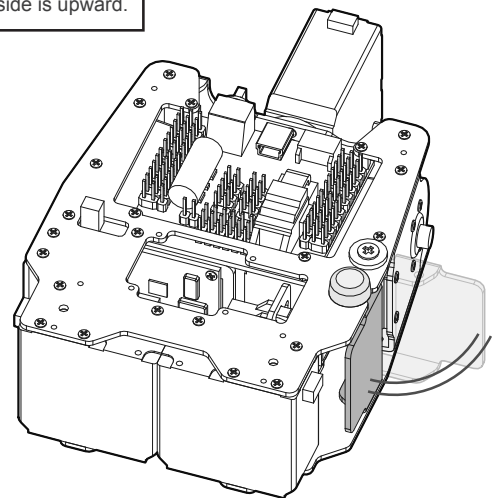

The shoulder is opened and closed depending on tightness of the urea resin screw.

7-6. Mounting the Arms and Legs to the Body (1)

Mounting the Right Arm

Prepare the required parts.

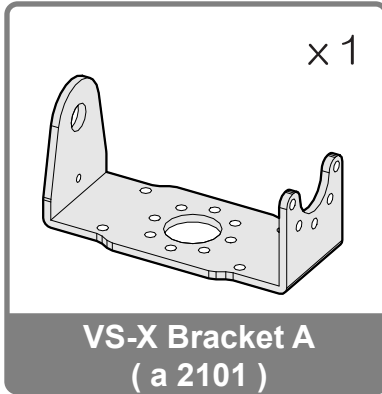

*This is not a VS-X bracket B.



*Confusion of M2-4 and M2-5 screws may damage the robot.

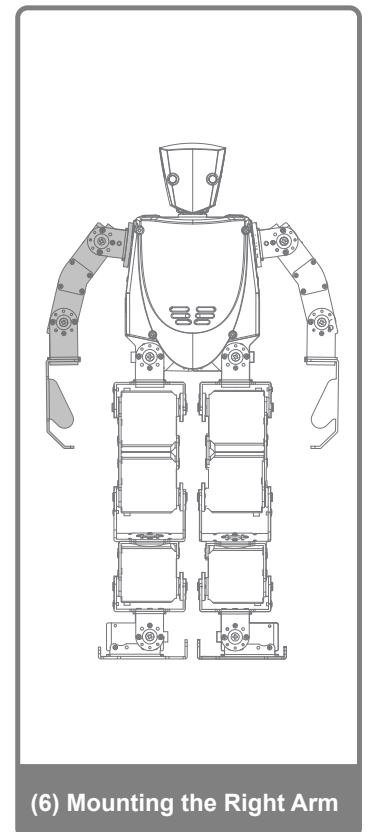
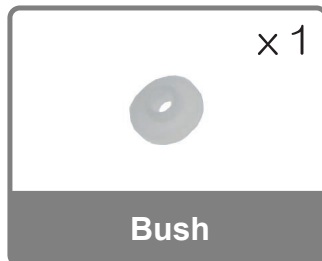
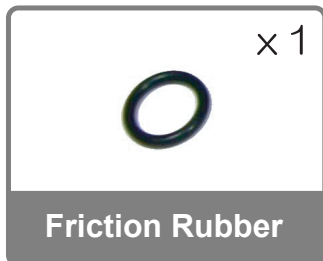

01. Mounting the Right Arm - 1

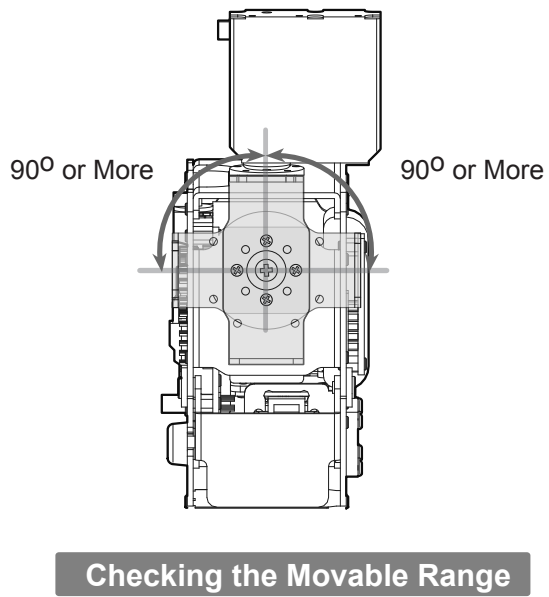
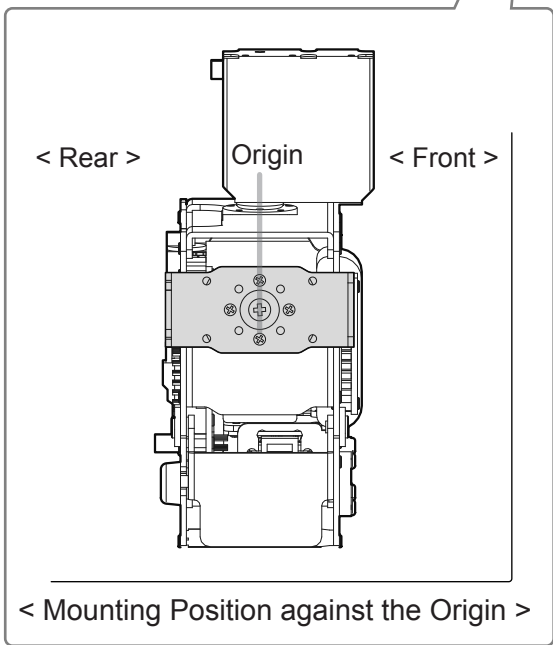
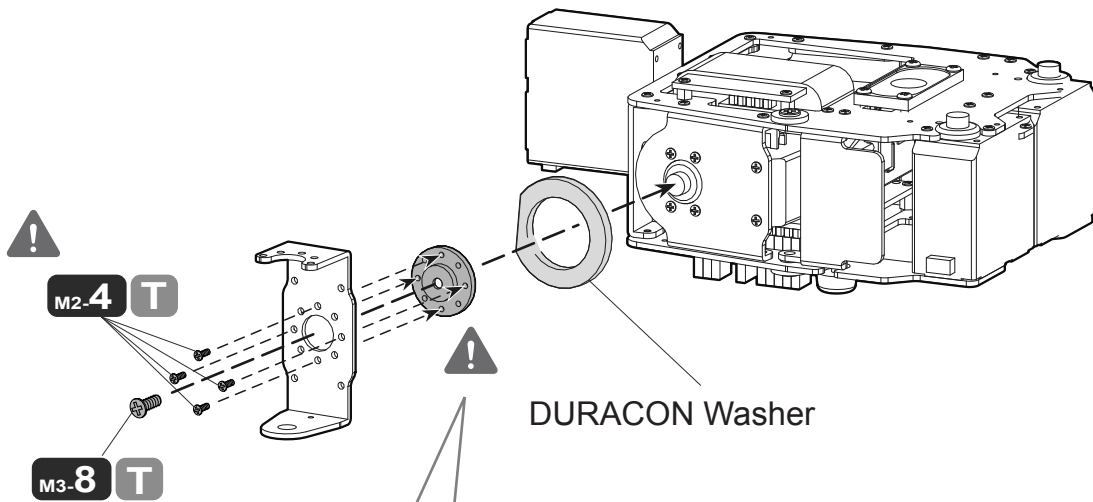

02. Mounting the Right Arm - 2

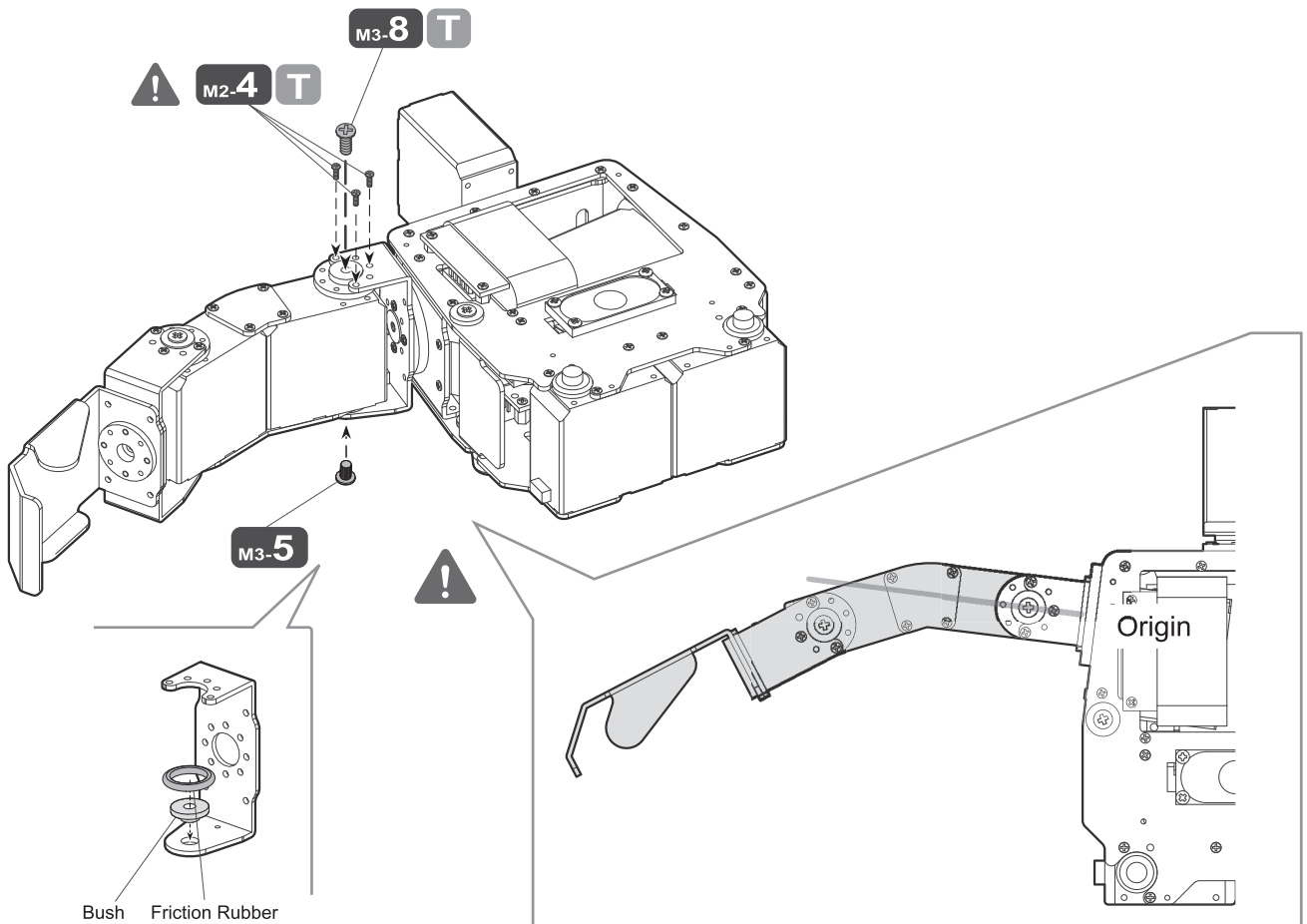

< Mounting Position against the Origin >

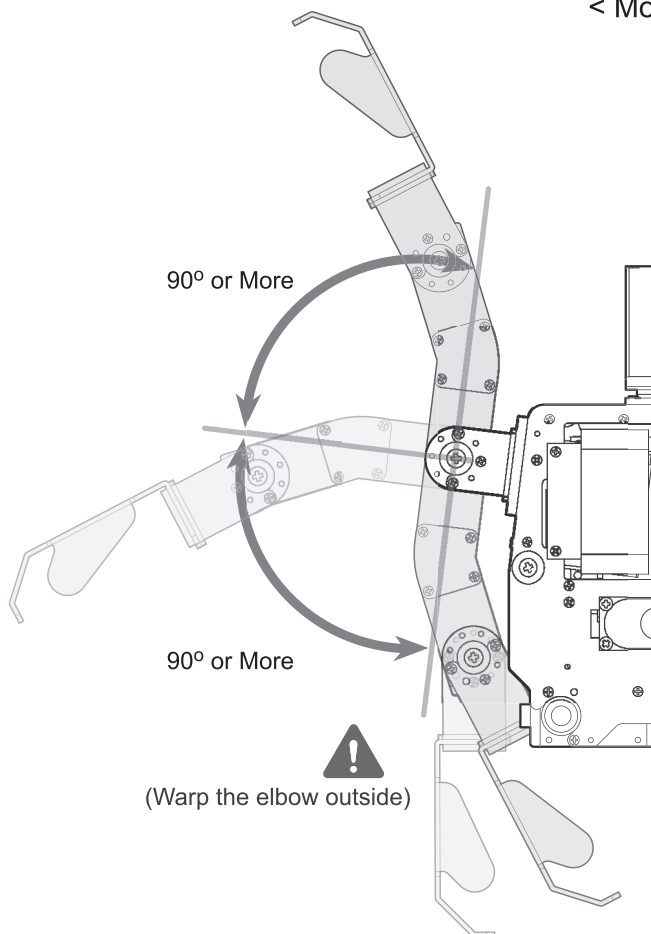

Checking the Movable Range

Mounting the Left Arm

Prepare the required parts.

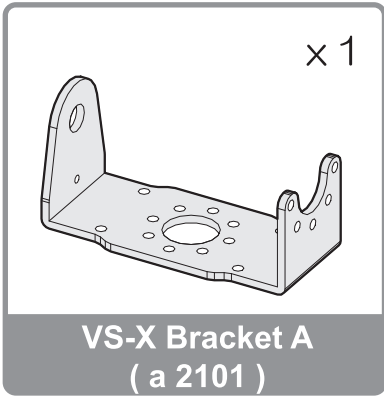

*This is not a VS-X bracket B.



*Confusion of M2-4 and M2-5 screws may damage the robot.

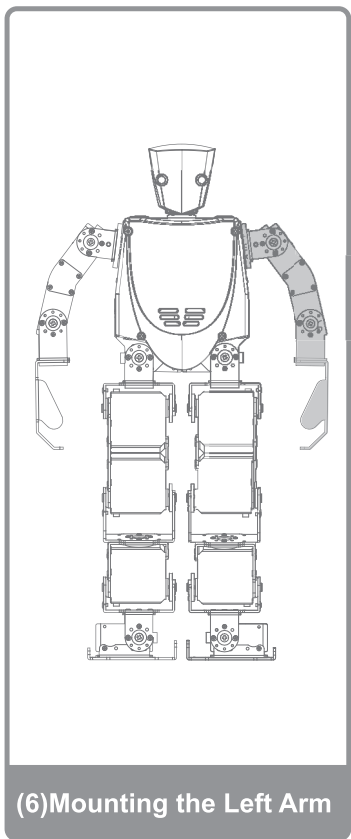
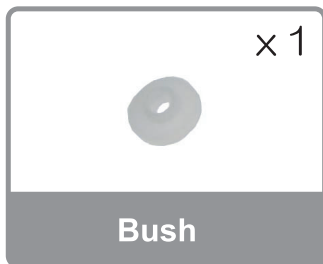
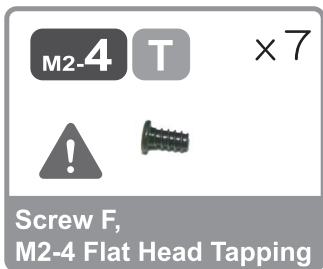

01. Mounting the Left Arm - 1

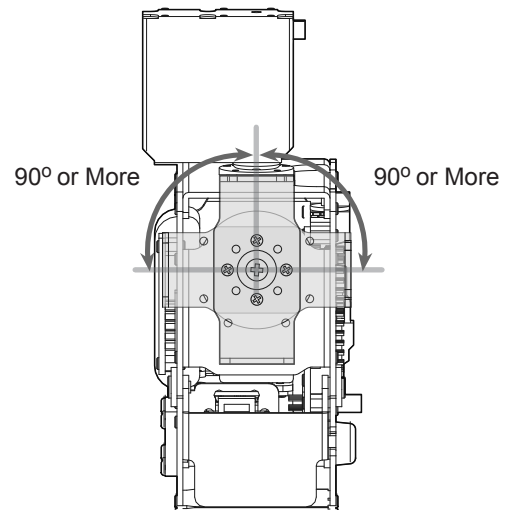
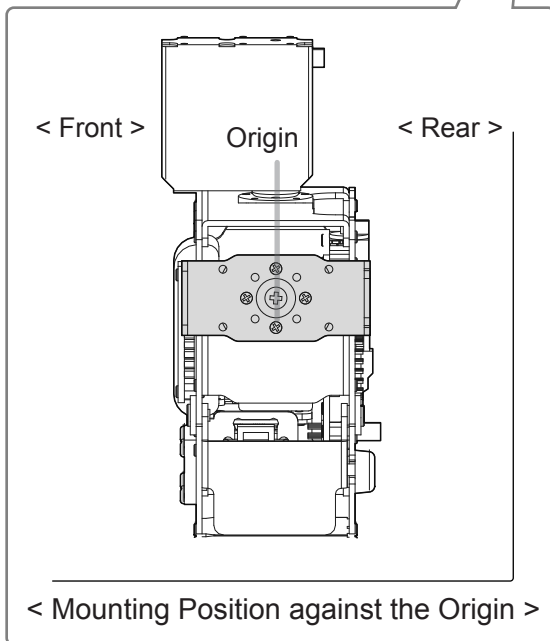
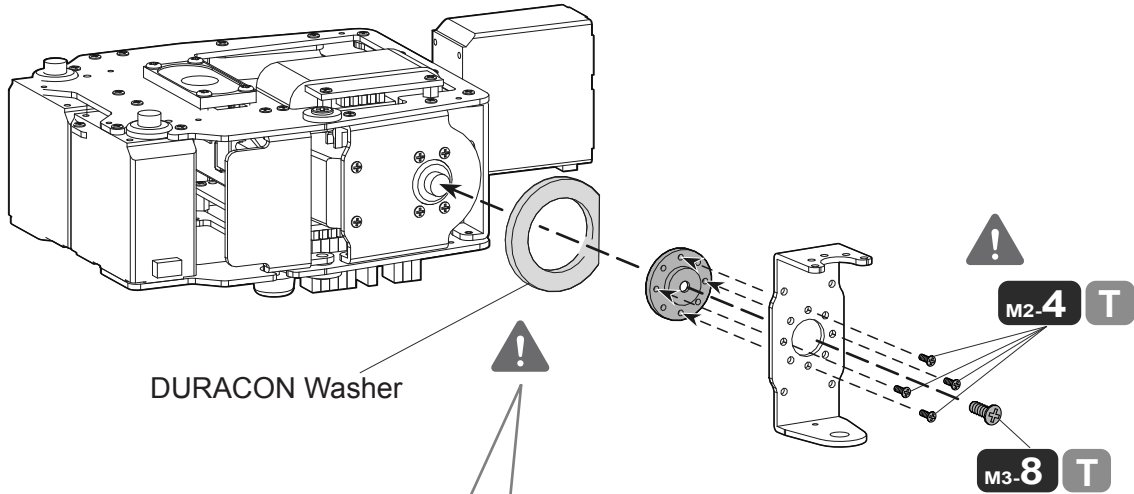

Checking the Movable Range

02. Mounting the Left Arm - 2

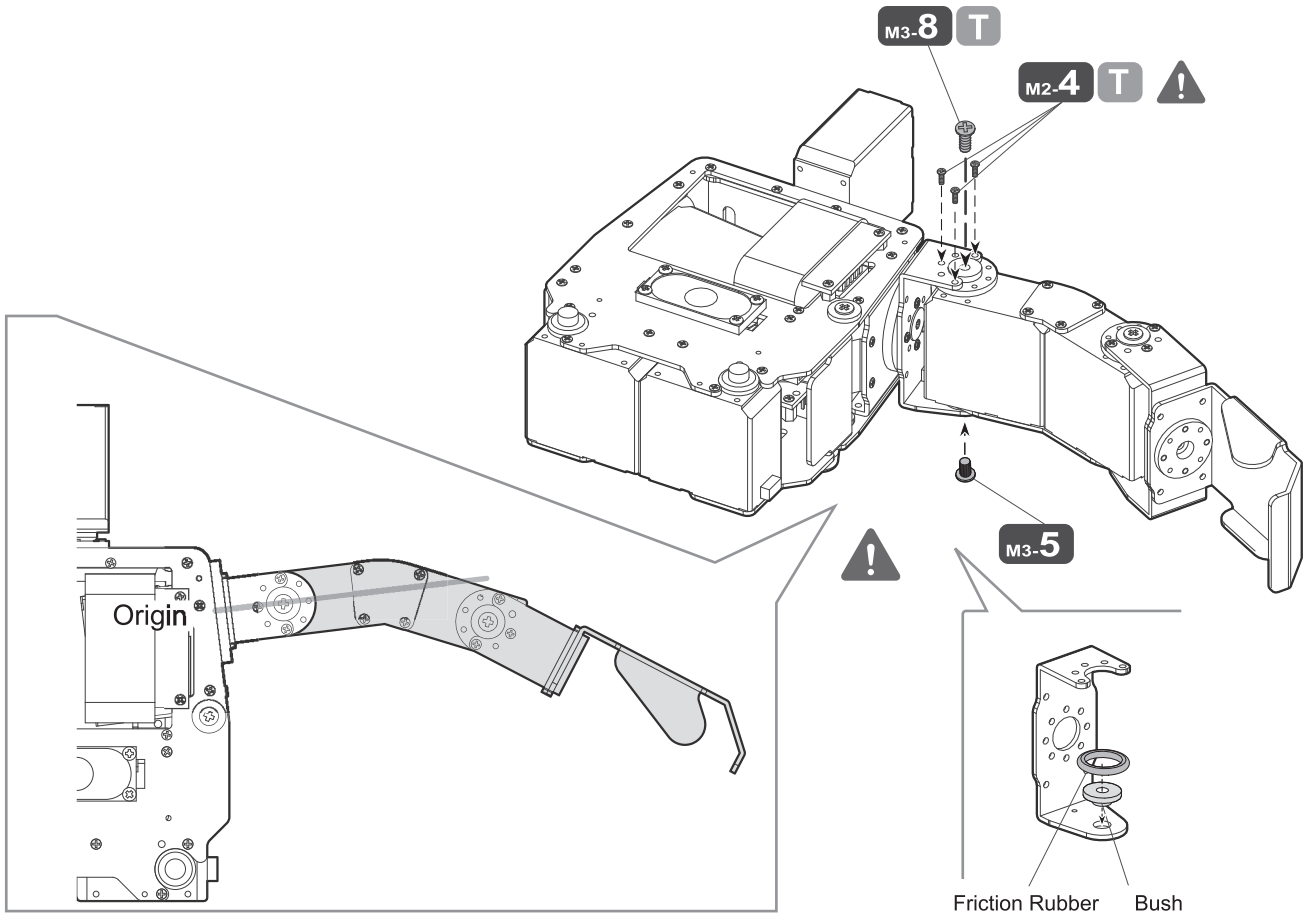

< Mounting Position against the Origin >

Checking the Movable Range

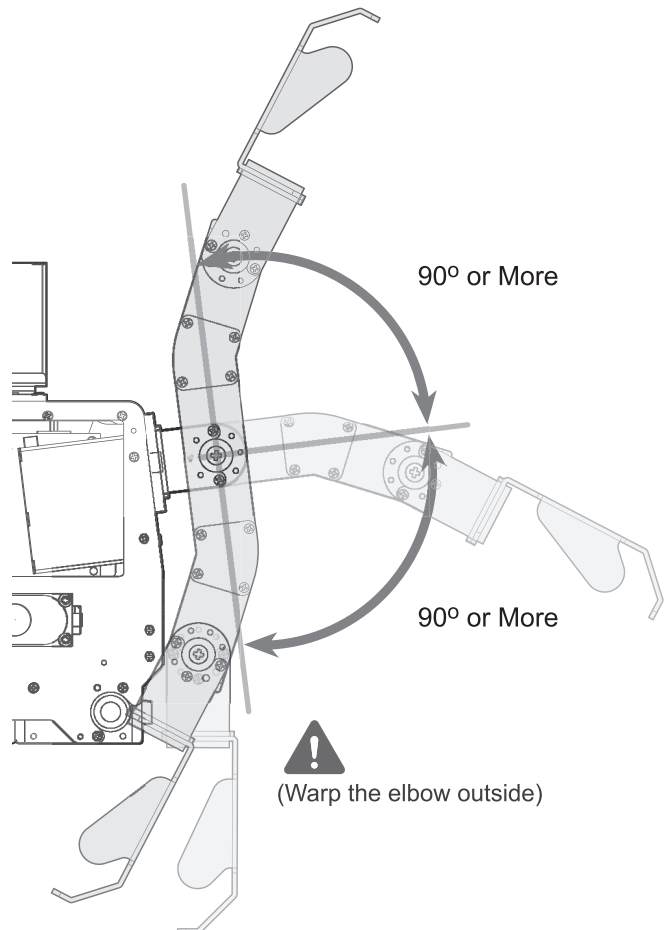

Mounting the Right Leg

Prepare the required parts.



*Confusion of M2-4 and M2-5 screws may damage the robot.

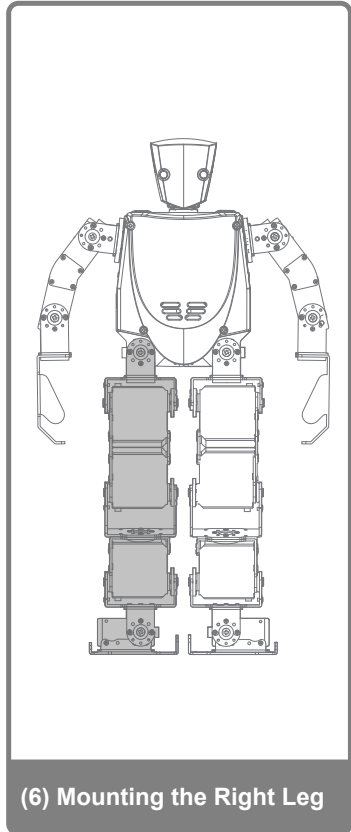
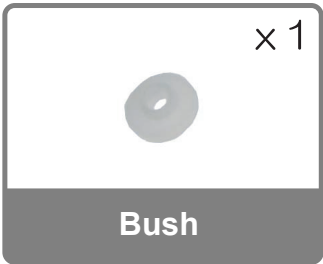
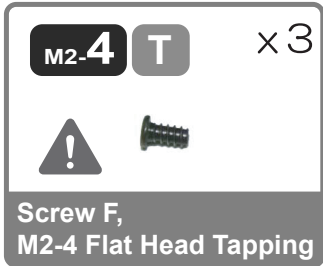

01. Mounting the Right Leg

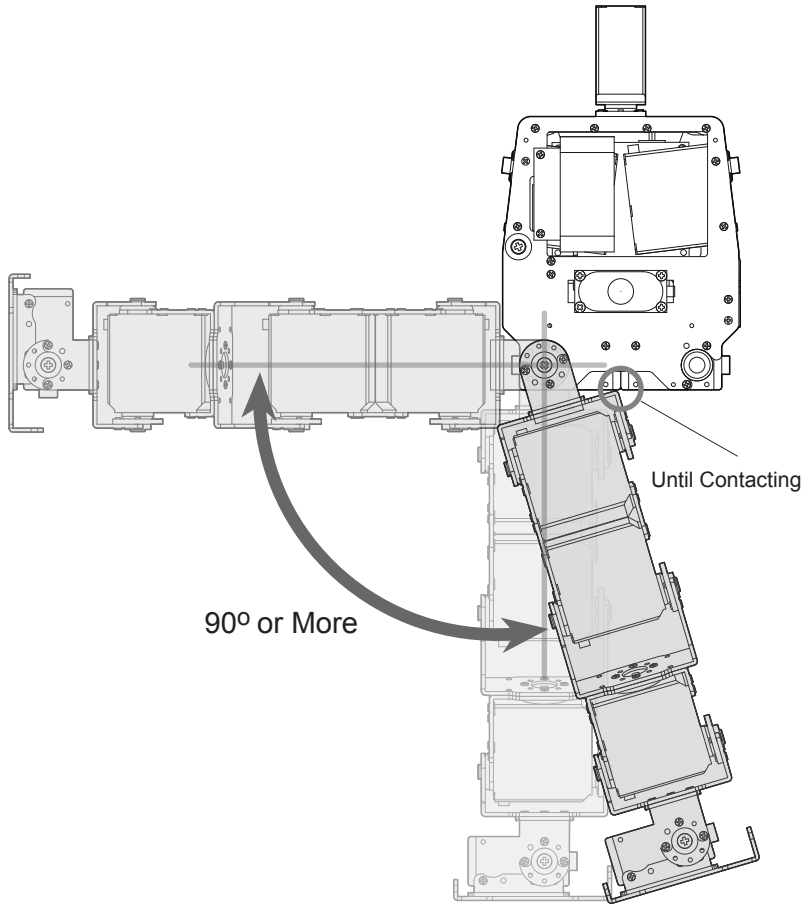
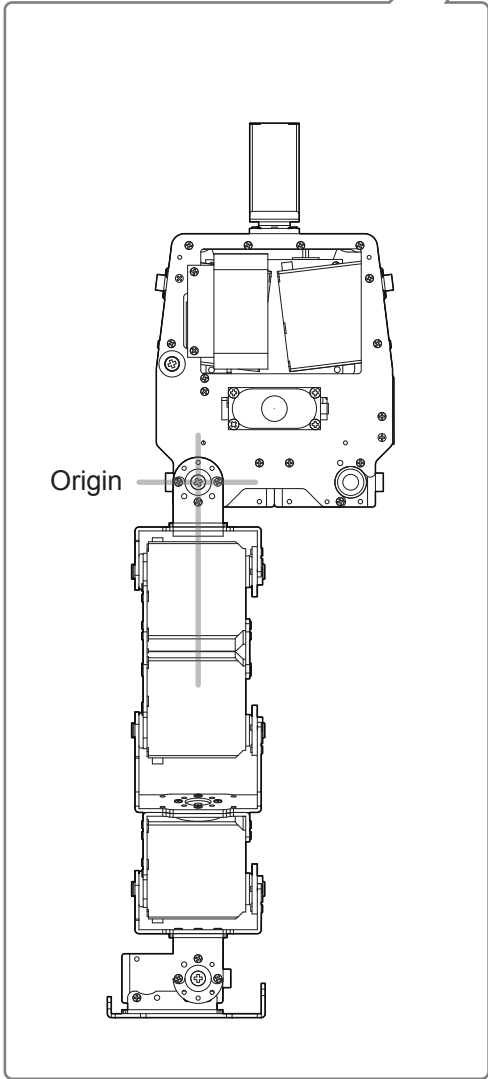
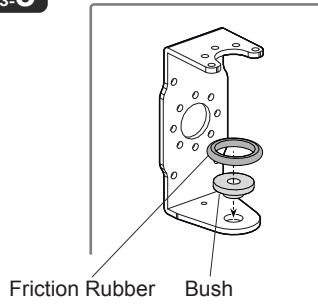
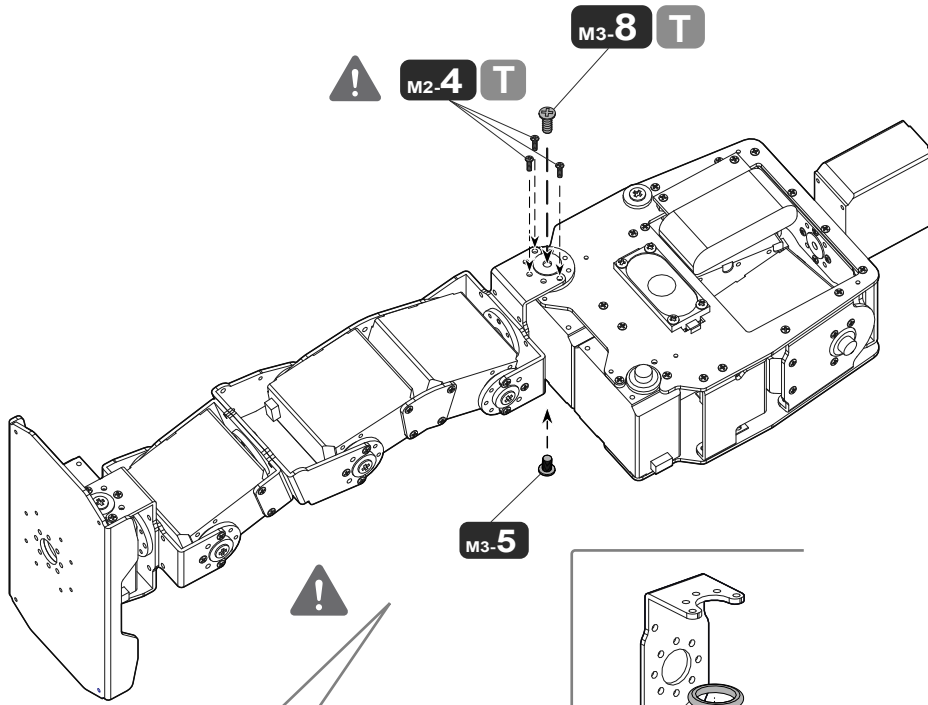

< Mounting Position against the Origin >

Checking the Movable Range

7-6. Mounting the Arms and Legs to the Body (4)

Mounting the Left Leg

Prepare the required parts.



*Confusion of M2-4 and M2-5 screws may damage the robot.

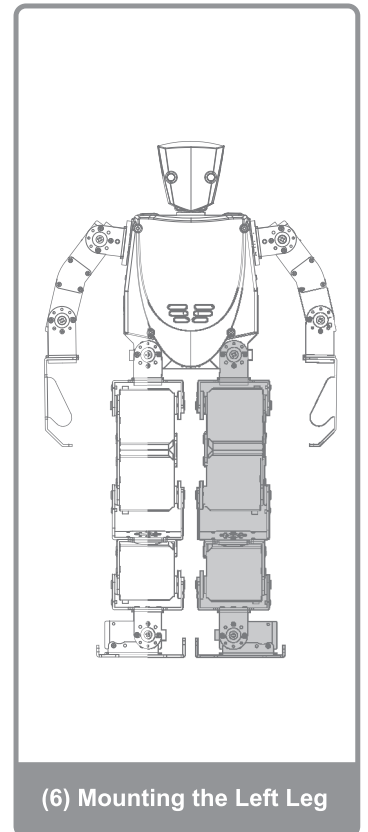
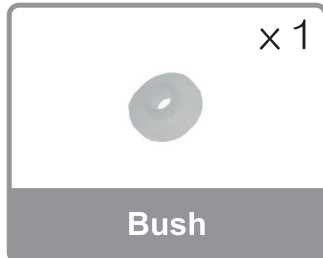
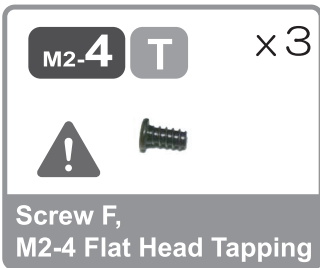

01. Mounting the Left Leg

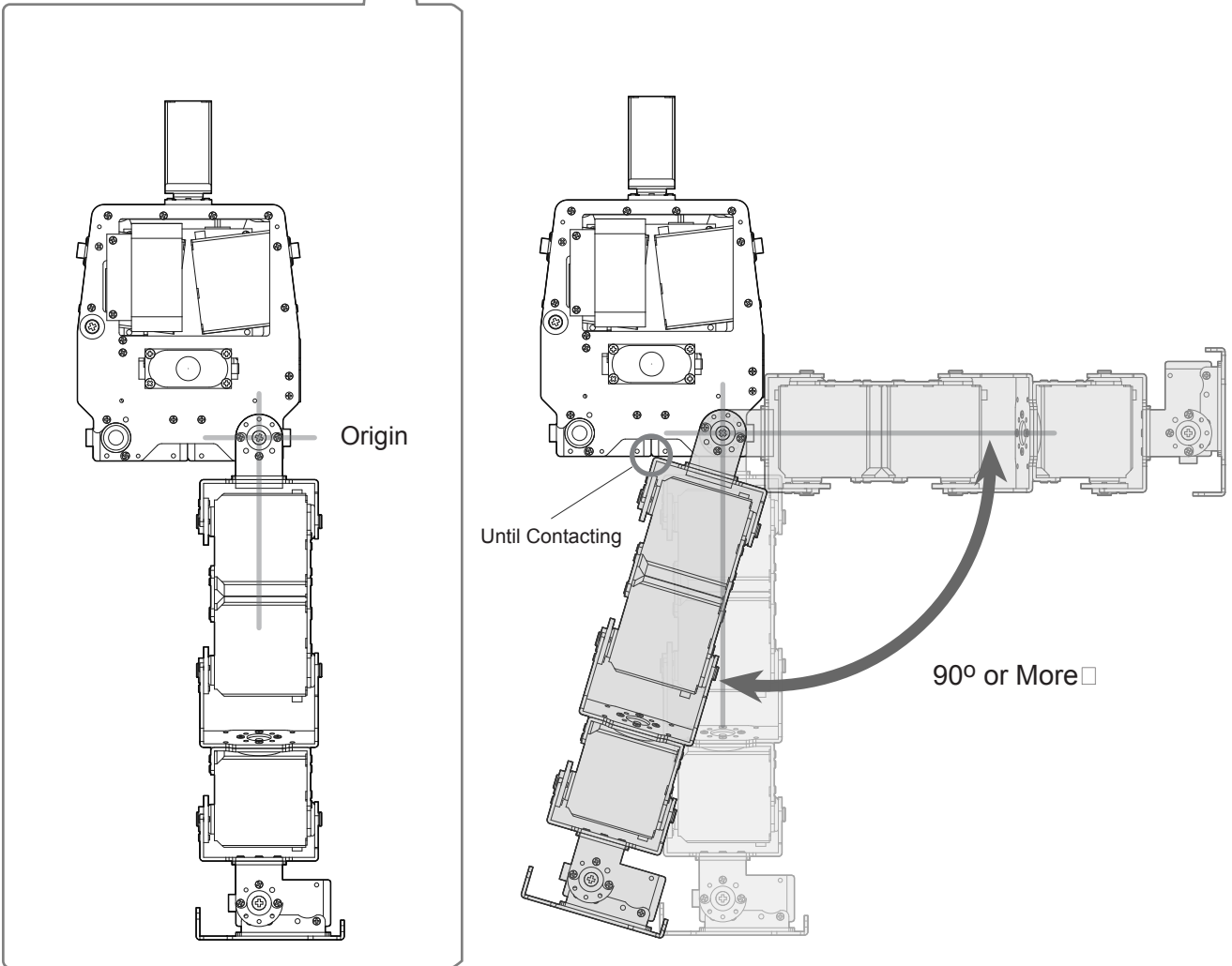
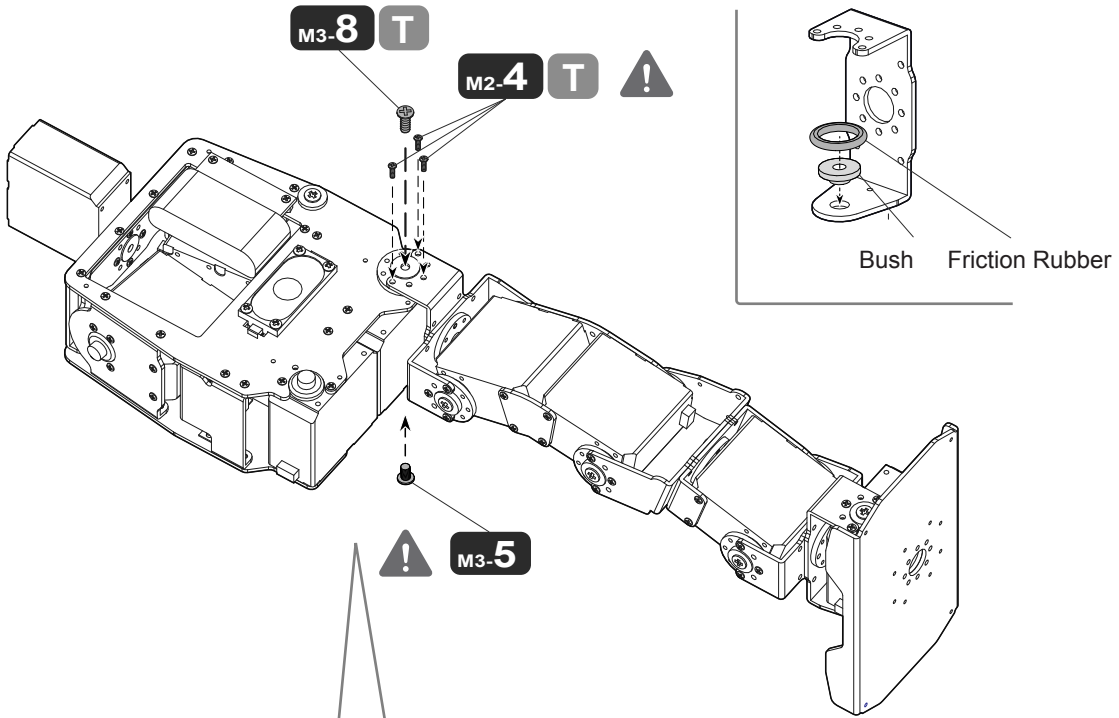

< Mounting Position against the Origin >

Checking the Movable Range

7-7. Checking the Movable Ranges (1)

Head and Right Arm

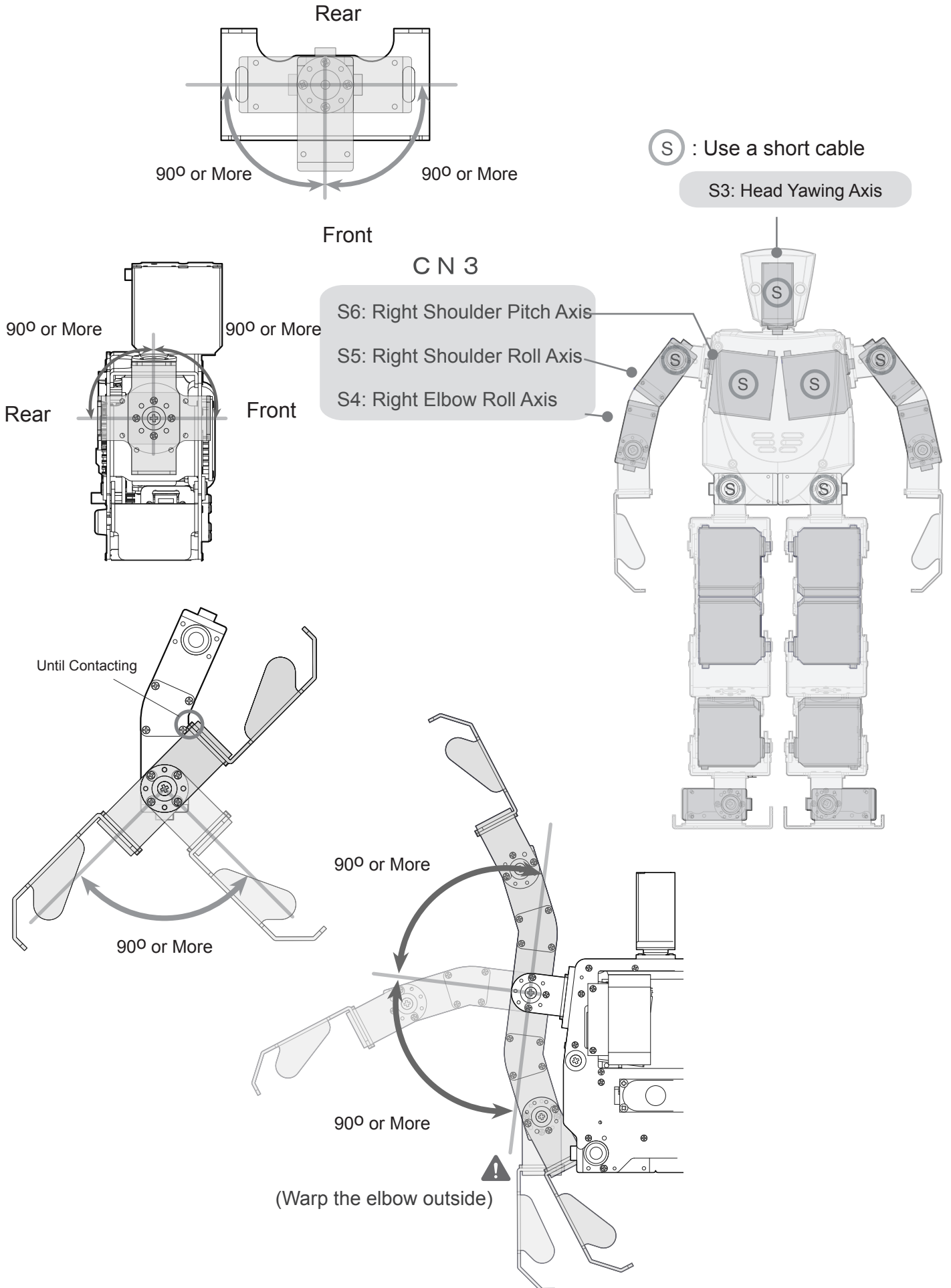

7-7. Checking the Movable Ranges (2)

Left Arm

C N 4

S6: Left Shoulder Pitch Axis

S5: Left Shoulder Roll Axis

S4: Left Elbow Roll Axis

Front

Rear

90° or More

90° or More

Until Contacting

90° or More

90° or More

90° or More



(Warp the elbow outside)

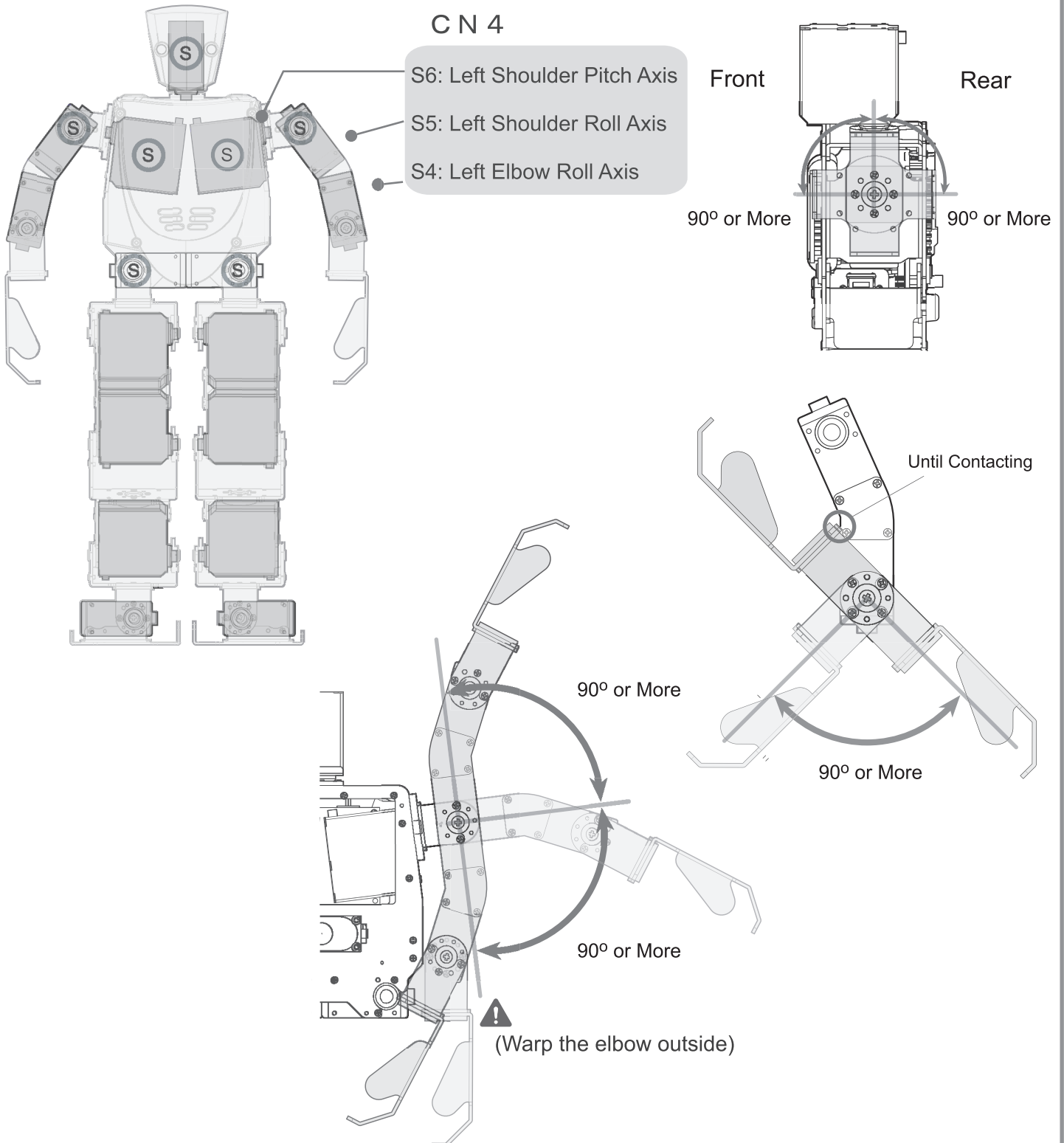

7-7. Checking the Movable Ranges (3)

Right Leg

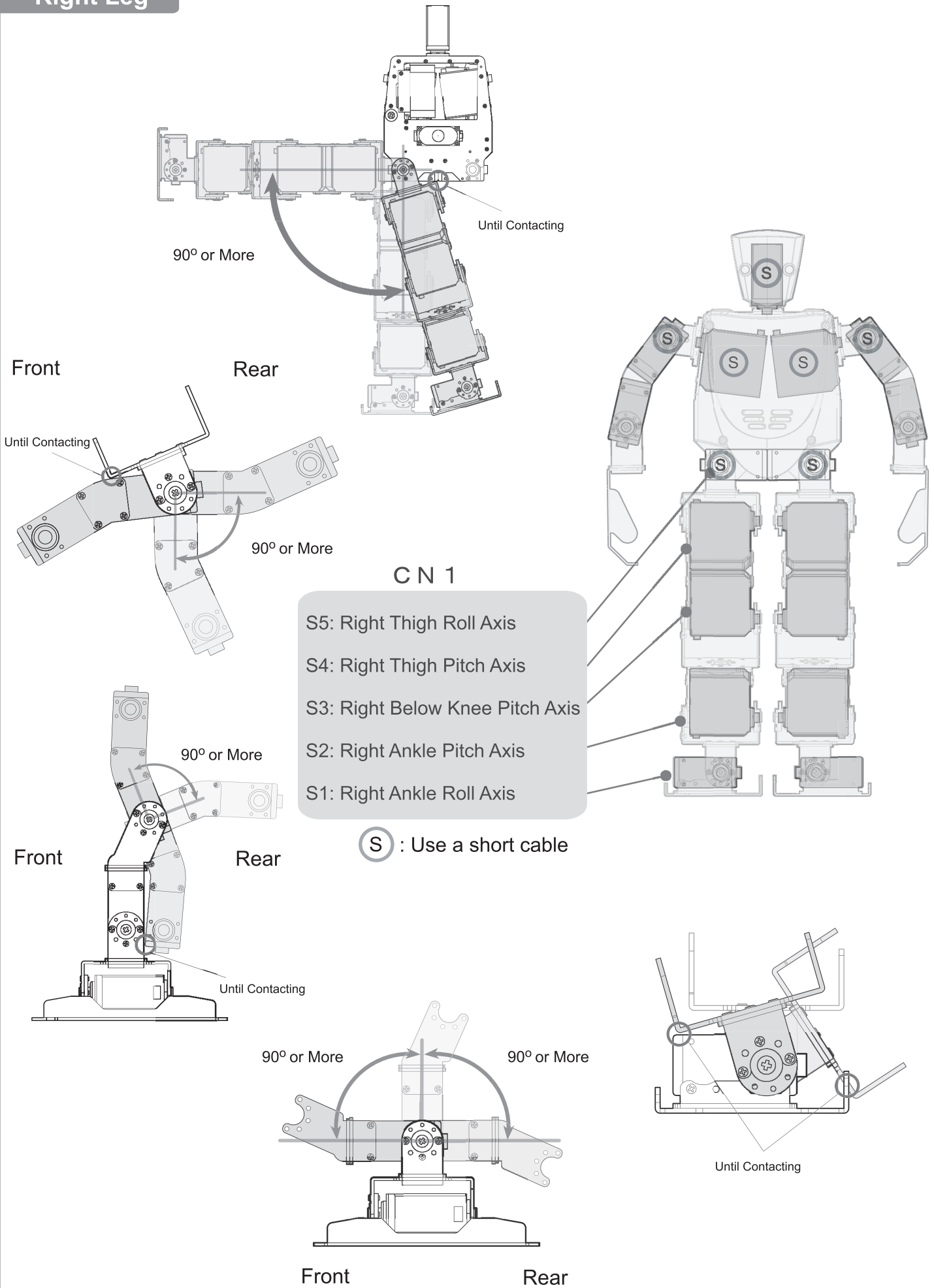

7-7. Checking the Movable Ranges (4)

Left Leg

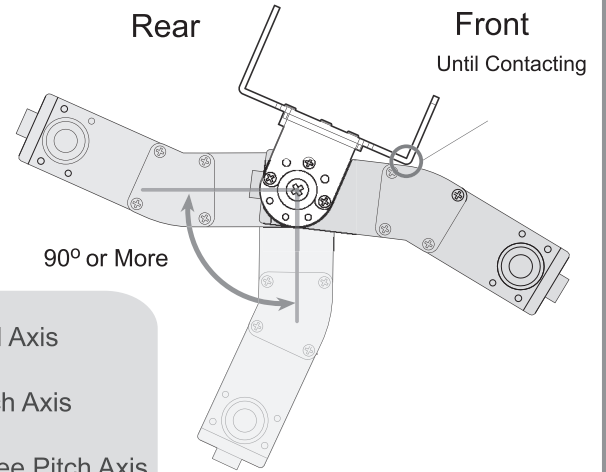
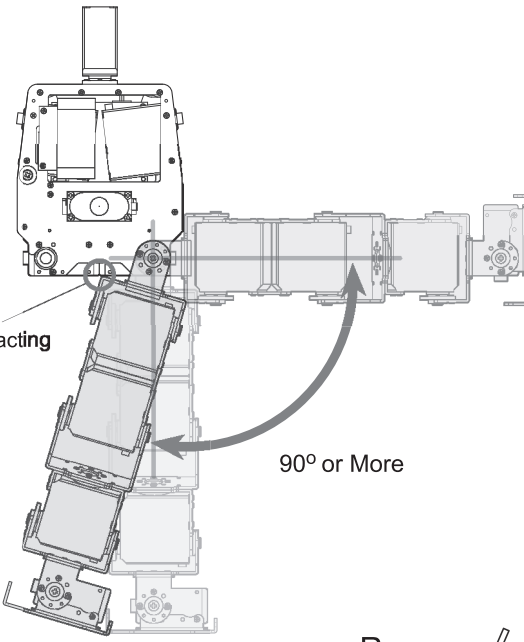
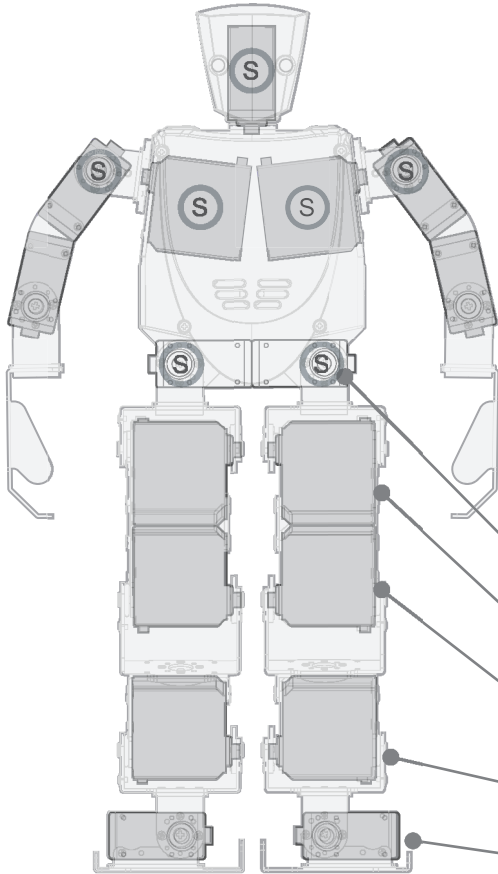

C N 2

- S5: Left Thigh Roll Axis
- S4: Left Thigh Pitch Axis
- S3: Left Below Knee Pitch Axis
- S2: Left Ankle Pitch Axis
- S1: Left Ankle Roll Axis

(S) :Use a short cable

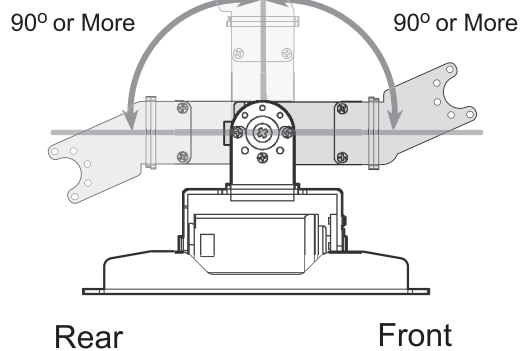
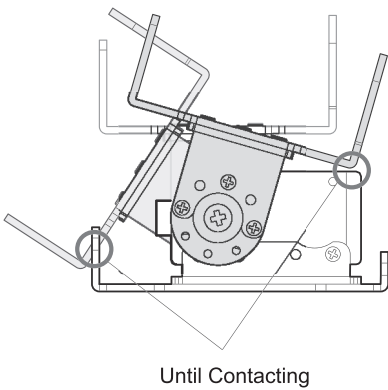
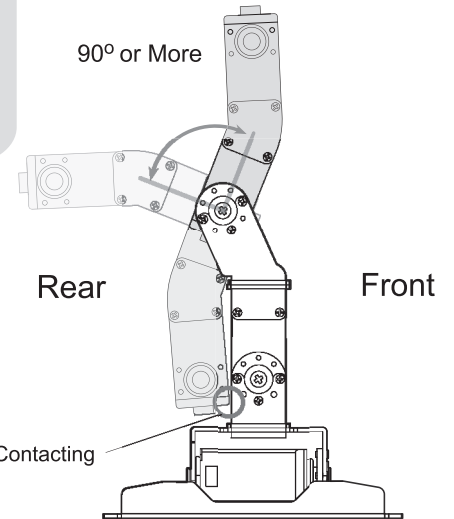

7-8. Wiring and Mounting the Head Armor (1)

Wiring

Prepare the required parts.

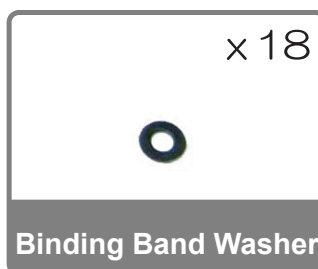

It is recommended to mark the connectors so that you can easily tell where they should be used.

01. Wiring the Arms

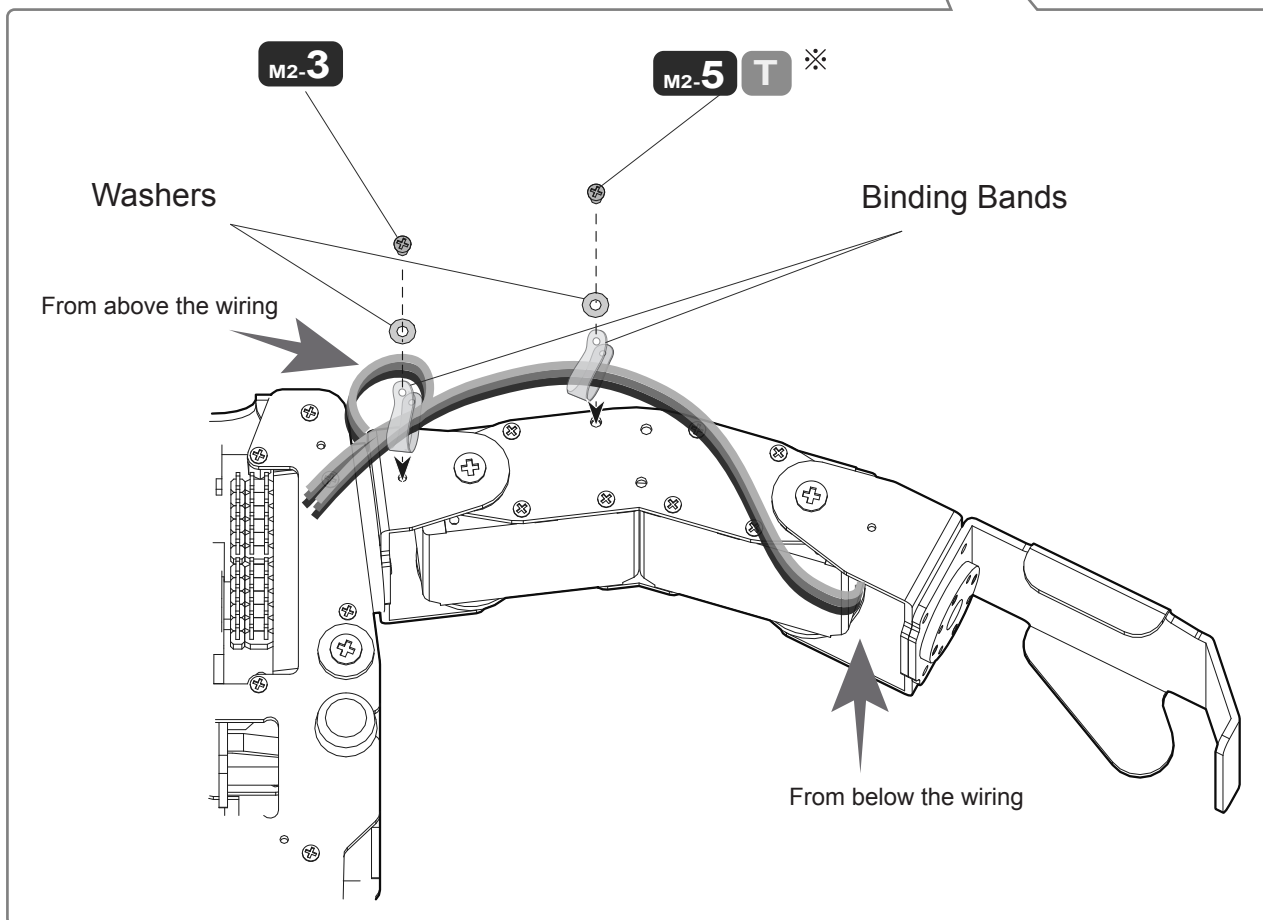
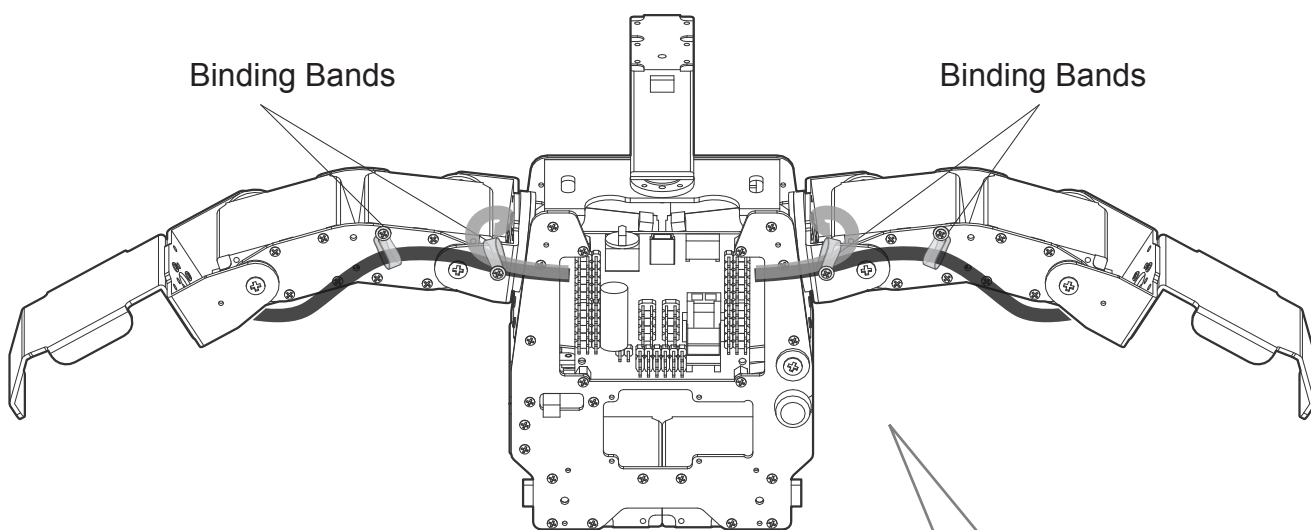

< How to Secure with the Binding Bands >

M2-5 T * Prior to securing the wiring with the binding bands, remove the relevant screws already attached in the previous assembly process.

02: Wiring the Legs

M2-3
Binding Band
Washers

M2-5 T ※
Binding Band
Washers

From behind the wiring

Wire the left leg in the same manner.

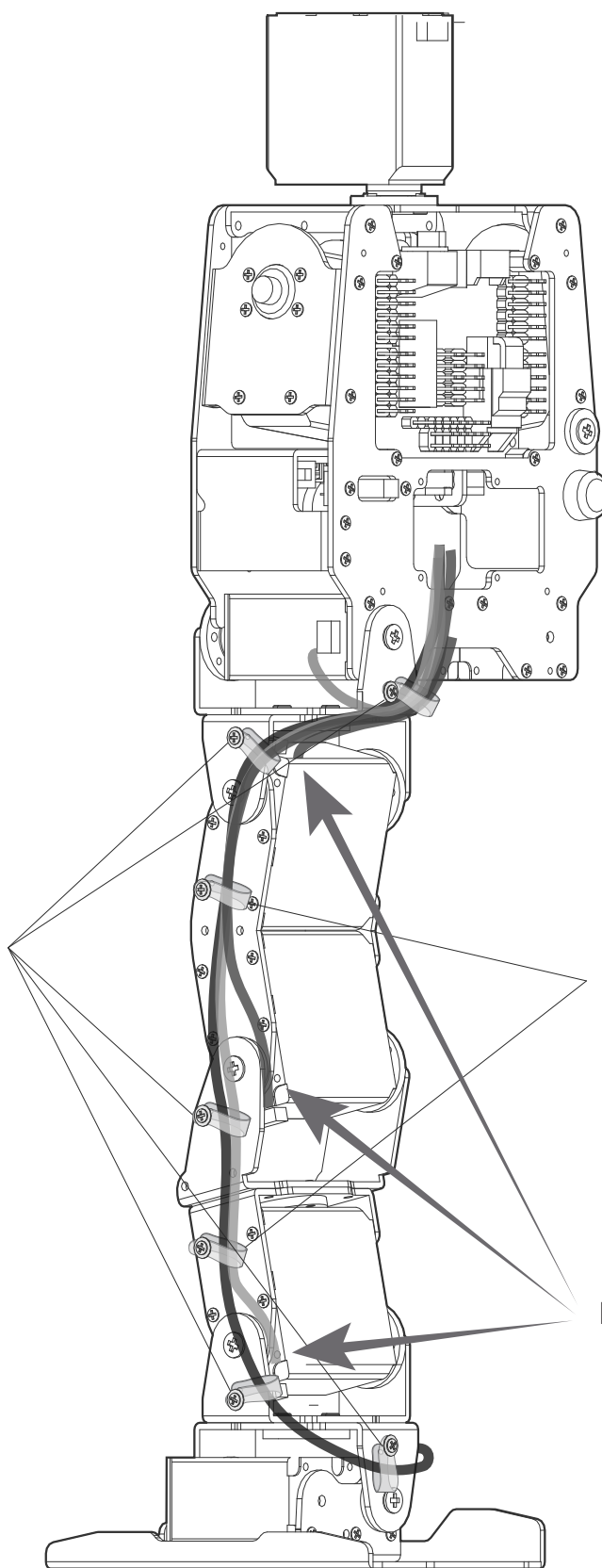

Mounting the Head Armor

Prepare the required parts.

One Each

Front of Head

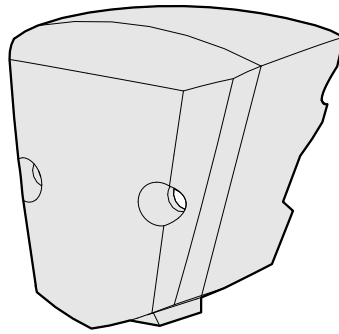

Rear of Head

Head Front Armor

Head Rear Armor

x2



LED Board
VS-LED1

M2-5 T x2



Screw E,
M2-5 Flat Head Tapping

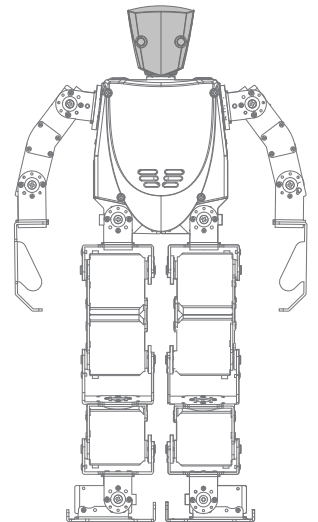

(8) Head

01. Mounting the Head Armor

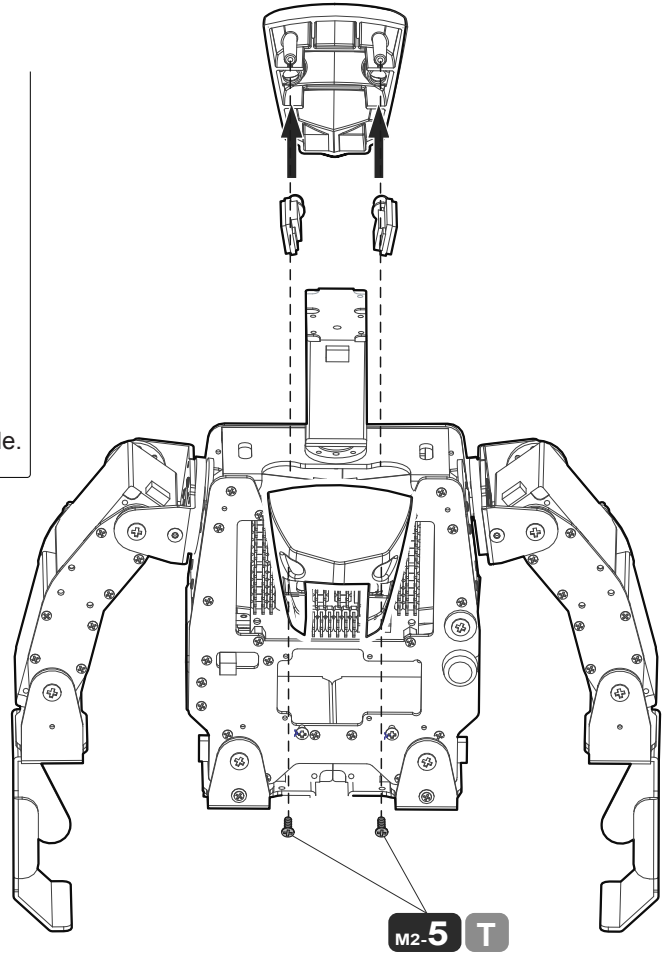
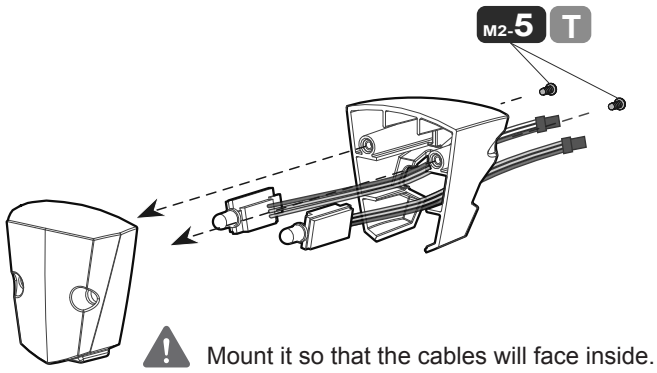

Wiring to the CPU

Wire all the servo motors and LEDs.

The following shows a connection diagram.

Seeing the figure below, connect the servo motor cables to the CPU.

*Prior to connecting, check a connecting position fully.

CPU (VR-RC003HV) Connection Diagram

 Note that erroneous wiring may damage the CPU or the servo motor.

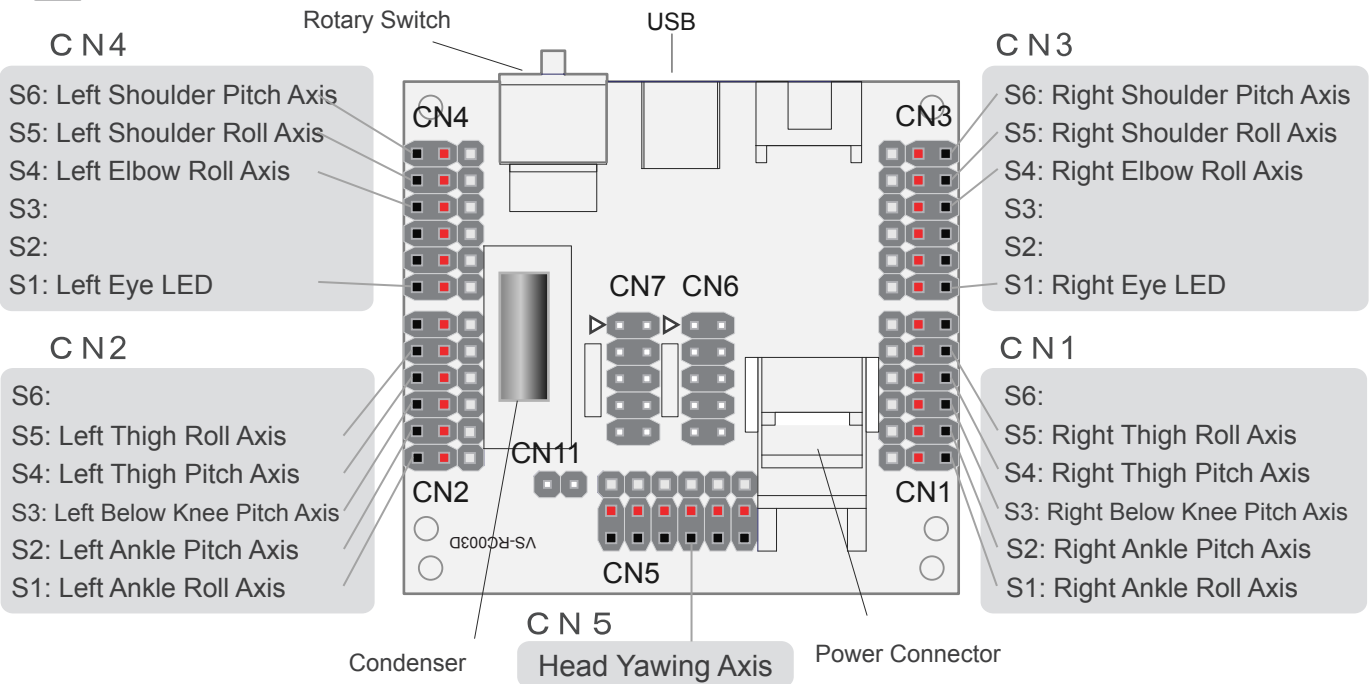

*S1, S2, and so on from the power source side (right)

CN1 to CN5: Servo motors, VS-LED 1
 CN6: Controller
 CN11: Speaker
 CN7: IXBUS (for an extension board)

<Cable Direction>

Servo motor: Cable colored in gray on the inside
 VS-LED 1: Cable colored in blue or gray on the inside
 Controller, IXBUS: Align a connector's mark "△" with "△" shown in the figure.
 Normally, align No. 1 pin with "△".
 Speaker: No polarity. Either cable will do.

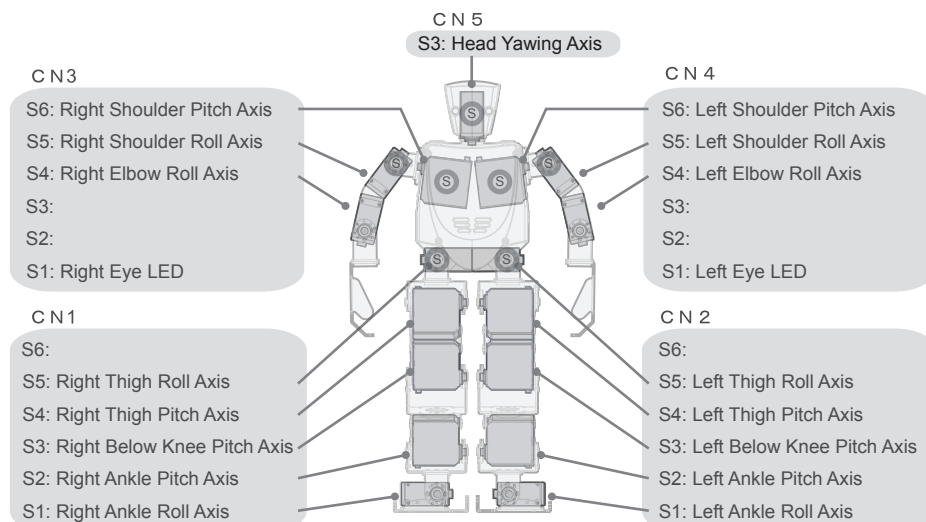

 : Use a short cable

7-9. Mounting the Body Armor

Prepare the required parts.

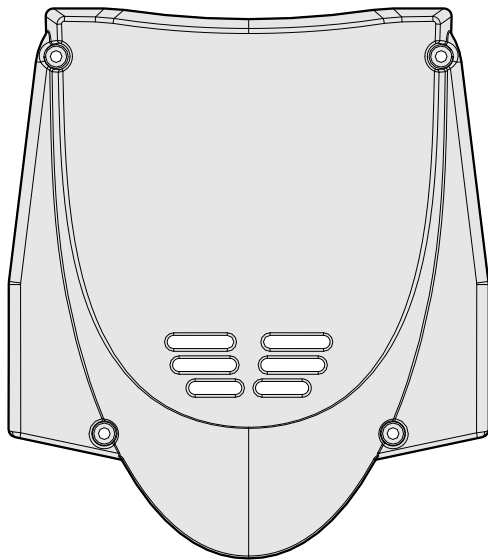

Body Front Armor

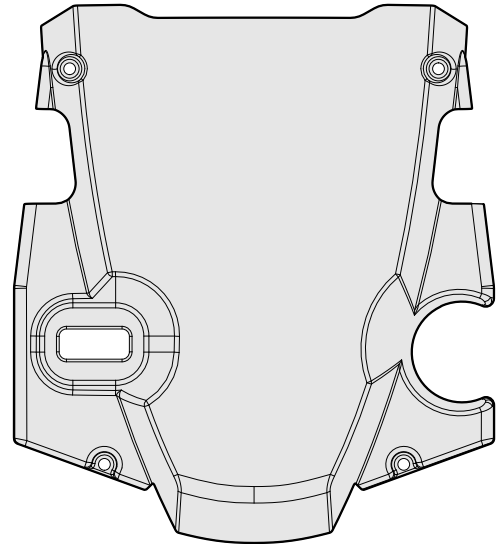

One Each

Body Rear Armor

M2-4 B x8



Screw G,
M2-4 Bind Tapping

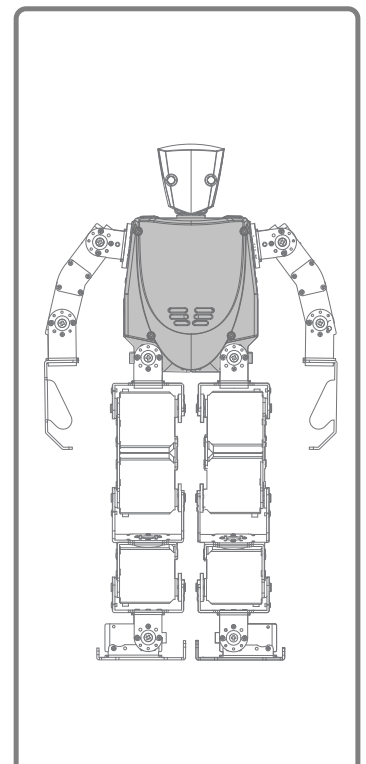

(9) Armor (Chest)

01. Mounting the Armor Panel (Rear)

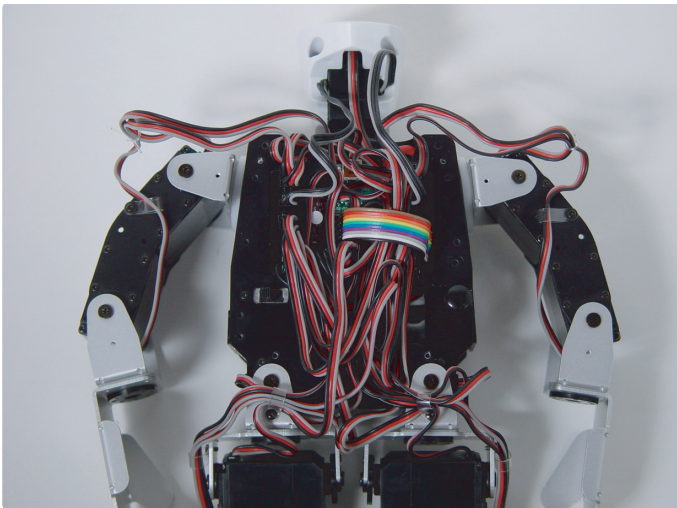
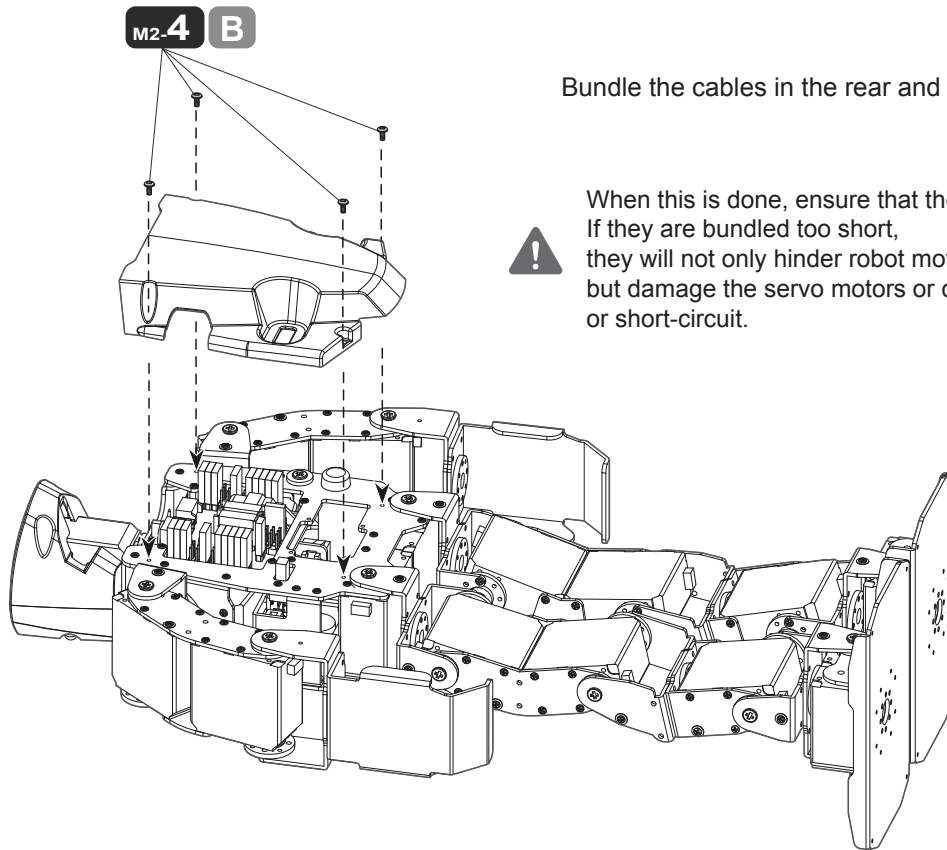

<Wiring Example>
Bundle the cables in the center of the body so that they will not be caught between the armor and the aluminum parts.

<Wiring Example>
When the gyro sensor* is mounted;
When the gyro sensor is mounted,
bundle its wiring in the center as well.
(* Optional)

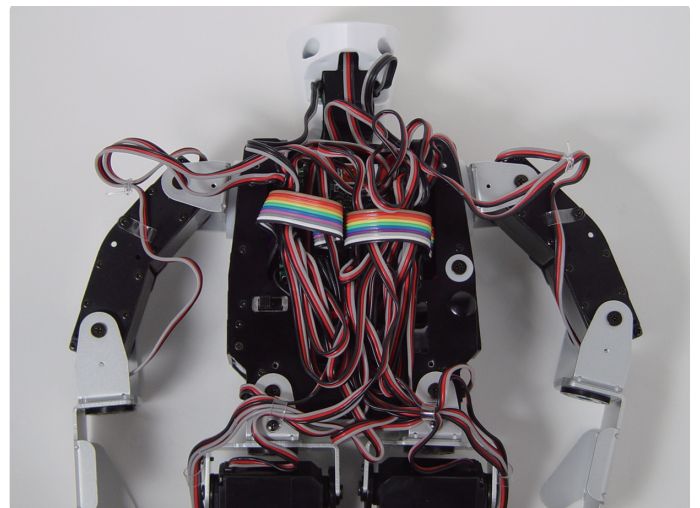

02. Mounting the Armor Panel (Front)

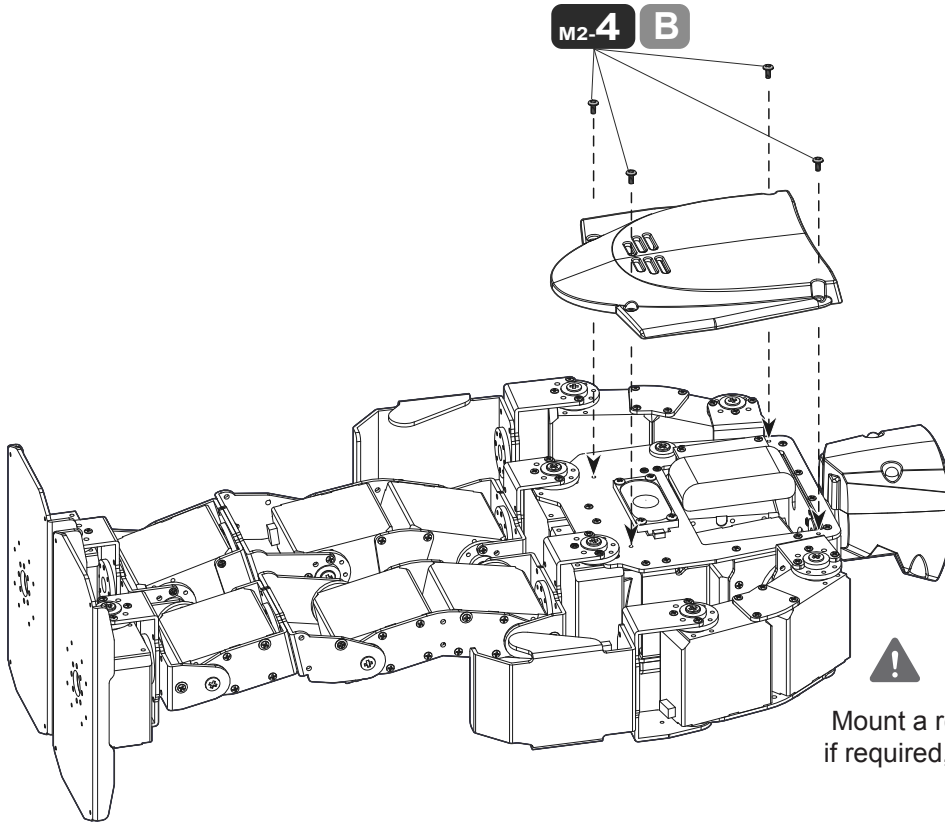

Mount a receiver for a radio game pad, if required, prior to mounting the armor.

Wiring Check

If the cables are bundled too short in the rear, they will not only hinder robot movements, but damage the servo motors or cause snapping or short-circuit.

If they are slackened too much, the robot will be caught by them, damaging the servo motors or causing snapping or short-circuit.

Move each of the robot joints to recheck whether or not the cables are too tight. The following checks the noteworthy areas.

03. Wiring Check (Neck)

Oscillate the neck to the right and left to check whether or not the cables are too tight.

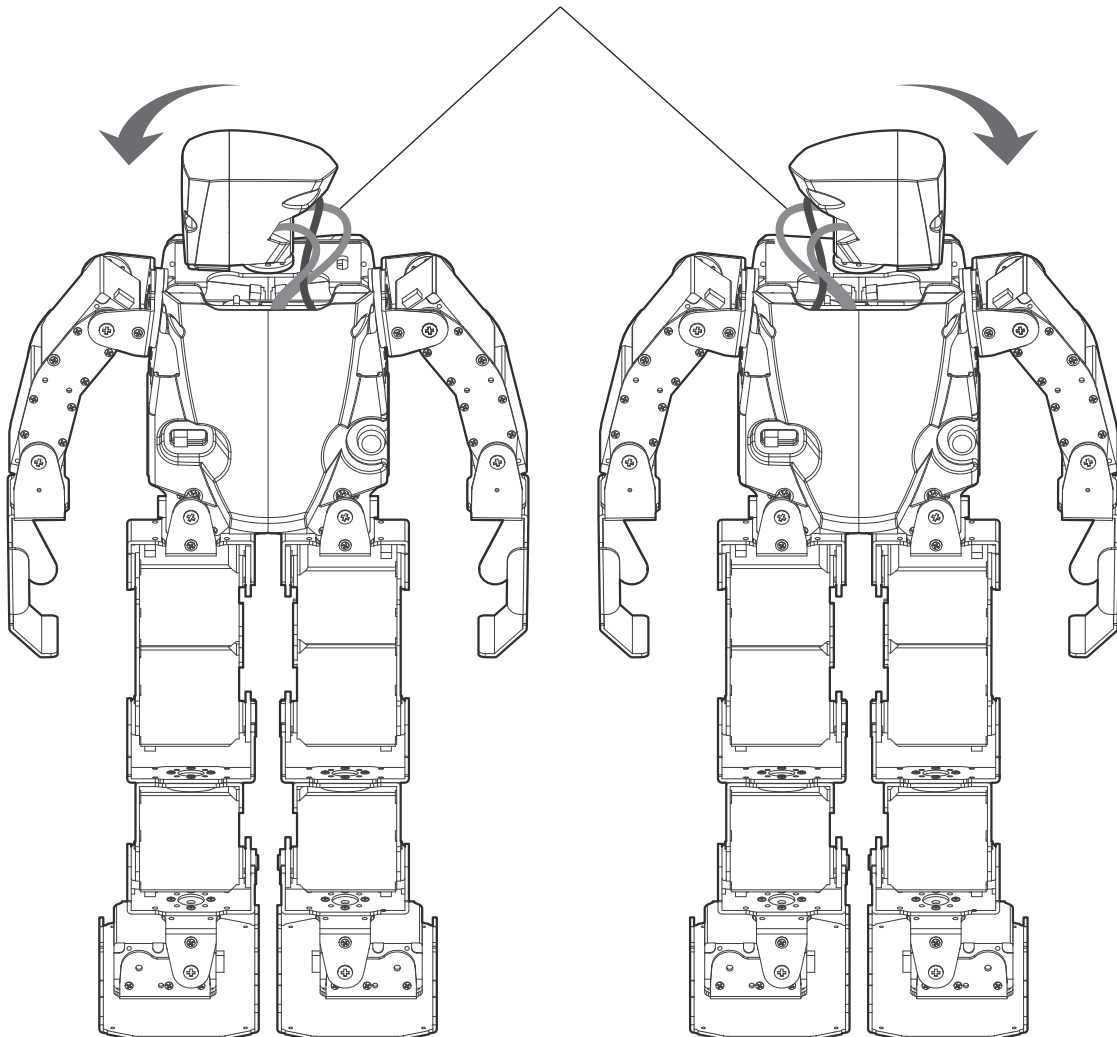

04. Wiring Check (Shoulder)

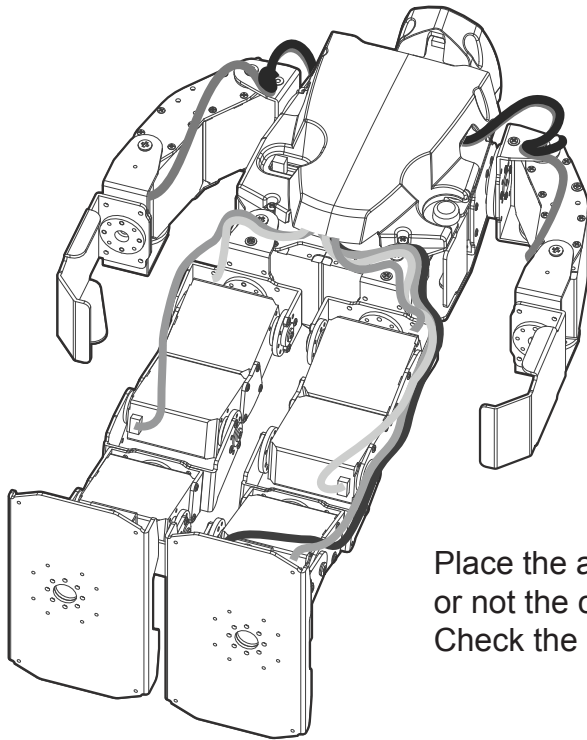

Place the arms in this condition and check whether or not the cables hinder arm movements.
Check the right and left arms.

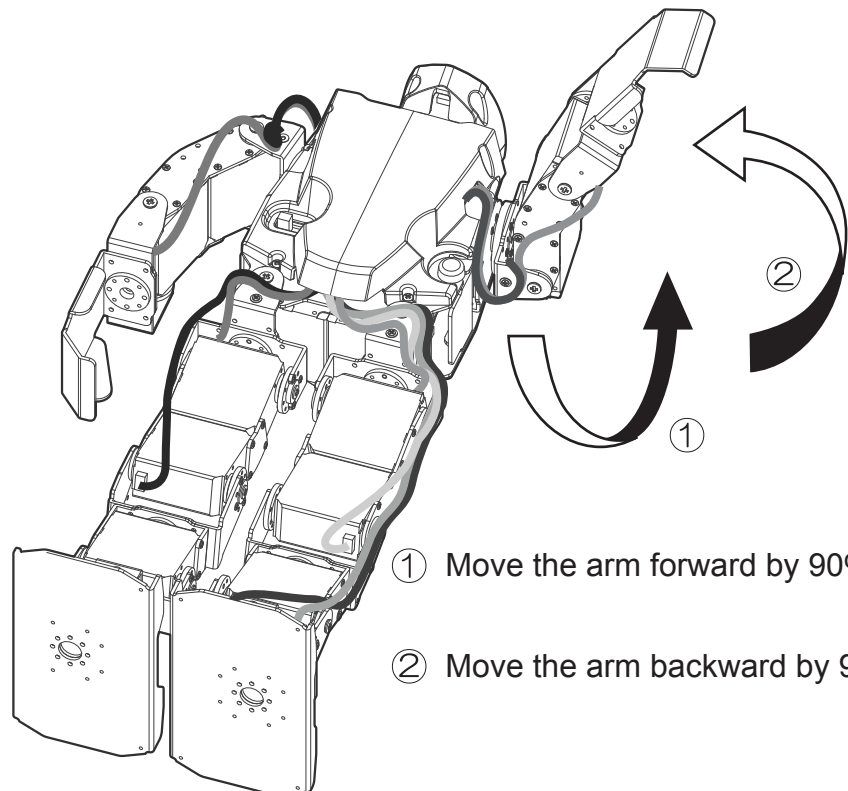

- ① Move the arm forward by 90°.
- ② Move the arm backward by 90°.

7-10. Pasting the Sole Tape

Prepare the required parts.



Pasting the sole tape produces adequate friction with the ground, allowing the robot to move stably.

01. Pasting the Sole Tape

Paste the tape free from air bubbles or wrinkles and cut it with scissors along the soles.

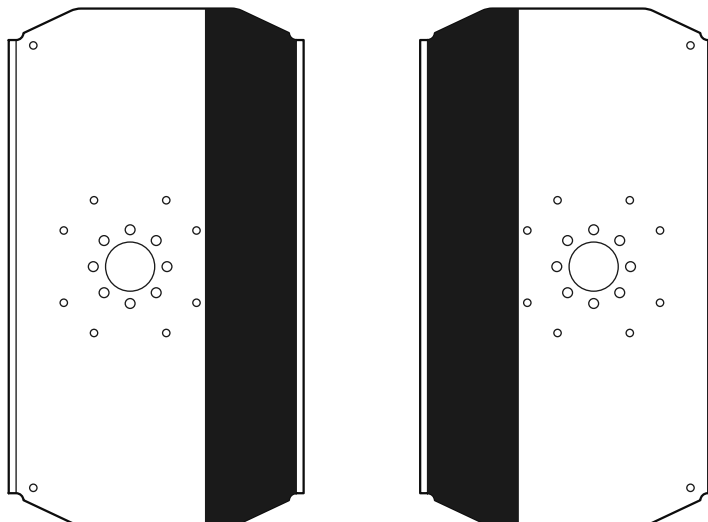

8. INSTALLATION OF BATTERY

Check: Check whether or not the power switch of the robot body has been **turned to OFF (outside)**.

- Loosen the urea resin screw to install the battery in the body.
- Install it so that the power cable will be routed on **the battery inserting side and the front side of the robot**.
- If the internal wiring is messed up, **the battery may not be properly installed**.
- Tidy up the wiring to install the battery. Tighten the urea resin screw firmly so that the battery will not come out while the robot is operating. Be careful not to tighten it too hard.

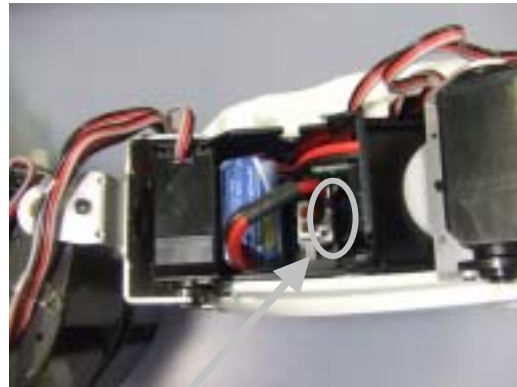

To removing the battery, hold down a pawl on its connector and pull out the connector. Do not pull its cable.

If you notice a foul odor or excessive heat generation, turn off the switch immediately and remove the battery.

Now, you are ready to operate the robot.
Proceed to "Robovie-X Software Reference."

9. INQUIRIES ABOUT TROUBLES, MISSING PARTS, DAMAGE, ETC.

- About Missing and Defective Parts

For missing and defective parts, check the relevant part names with the List of Parts Used. We will replenish or replace them. (Contact us by e-mail, fax, telephone or letter.)

- When You Suspect a Trouble

In case the robot cannot be properly assembled or operated, let us know a phenomenon in details by e-mail, telephone, fax or letter. We will investigate the case and contact you.

Vstone Co., Ltd.

E-mail: infodesk@vstone.co.jp

Phone: 06-6467-6601 Fax: 06-6467-6602

Address: 4-4-11 Shimaya, Konohana-ku, Osaka, 554-0024

URL: <http://www.vstone.co.jp/>

Office hours: 9:00 to 12:00 and 13:00 to 18:00
on Monday thru. Friday (except holidays)

User Support Service

Shop Support Service (Irregular, Free of Charge)

Venue: Osaka (Nipponbashi), Tokyo (Akihabara)

To be informed prior to implementation at <http://www.vstone.co.jp/>.

Manufacturer's robot specialty shop

"ROBO-PRO Shop" (Fukuoka, Kyushu)

2-3-2 Momochihama, Sawara-ku, Fukuoka, Fukuoka Pref., 814-0001

TVC Housoukaikan 2 Fl., Robo Square

Phone: 092-821-4111

URL: <http://www.vstone.co.jp/roboproshop/>

Community Space for Robot Users "ROBO-PRO Station"

(To be held monthly in Osaka and Tokyo)

A full-fledged robot fighting ring and a football field will be provided in addition to user support. Machining tools will be also available.

For details, see our URL (<http://vstone.co.jp/top/robo-prostation/>).

*The services above are subject to change or termination without prior notice.

APPENDIX: EXTENSION OF FUNCTIONS

Mounting the Optional Part

An optional extension board can be mounted to the back of Robovie-X.

The extension board allows addition of LEDs or more advanced programming such as reading the information of a distance sensor, switch, etc. into Robovie-X to behave according to the circumstances.

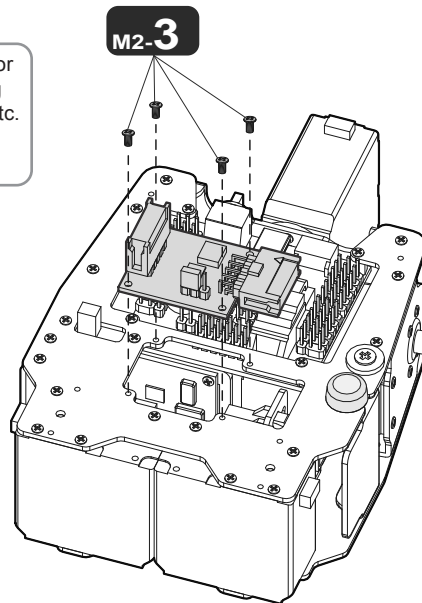

<Mounting the Extension Board VS-IX Series>

*If the VS-IX001 (gyro/acceleration sensor extension board) is mounted to the back, the robot will not function properly. Seeing Page 41, mount it inside the body.

Extension Board "VS-IX" Series

Gyro/Acceleration Sensor Extension Board

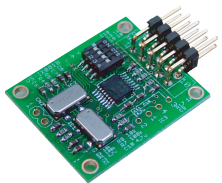

「VS-IX001」

This subminiature extension board has a 2-axis gyro sensor and a 3-axis acceleration sensor mounted onto it. Robot posture control by the gyro sensor, and the acceleration sensor are capable of detecting tumbling of the robot and

[Major Specifications]

Dimensions:25mmx30mm

Sensors mounted:

2-axis gyro sensor, 3-axis acceleration sensor

¥18,270

(Tax included)

LED Extension Board

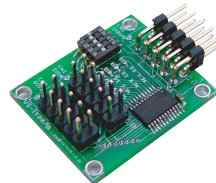

「VS-IX004」

This extension board is capable of control 16 channels of LEDs. It can use of PWM to control the LEDs, and set their brightness in 256 stages.

[Major Specifications]

Dimensions:25mmx30mm

LED control line: PWM system, 2 channels

LED output: 16 channels

¥3,150

(Tax included)

Digital I/O Extension Board

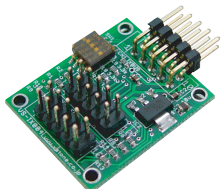

「VS-IX007」

This extension board is equipped with 16 channels of digital I/O ports. A switch can be connected to digital input to detect an obstacle and change the advancing direction, or a LED is connected to digital output to light it up.

[Major Specifications]

Dimensions:25mmx30mm

Digital I/O: 16 channels

(8 channels x 2, shared by the I/O ports)

¥3,150

(Tax included)

Analog Input Extension Board

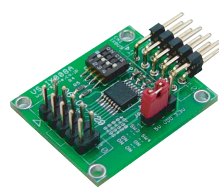

「VS-IX008」

This extension board is equipped with 8 channels of analog input ports. A PSD sensor, etc. can be connected to feed back motion and posture signals to the servo motors, etc. according to the sensor information.

[Major Specifications]

Dimensions:25mmx30mm

Analog input: 8 channels

¥4,200

(Tax included)

X-ON Electronics

Largest Supplier of Electrical and Electronic Components

Click to view similar products for [Development Boards & Kits - Other Processors](#) category:

Click to view products by [Seeed Studio](#) manufacturer:

Other Similar products are found below :

[EVB-MEC1418MECC](#) [20-101-1252](#) [C29XPCIE-RDB](#) [CC-ACC-18M433](#) [MAX1464EVKIT](#) [RTE510Y470TGB00000R](#)
[RTK0EN0001D01001BZ](#) [MAXQ622-KIT#](#) [YR0K505231S000BE](#) [YR0K50571MS000BE](#) [YQB-R5F1057A-TB](#) [QB-R5F104PJ-TB](#) [CC-](#)
[ACC-ETHMX](#) [OV-7604-C7-EVALUATION-BOARD](#) [SK-AD02-D62Q1747TB](#) [SK-BS01-D62Q1577TB](#) [ST7MDT1-EMU2](#) [GROVE BASE](#)
[KIT FOR RASPBERRY PI](#) [RTK5572TKCS00000BE](#) [CAB M-M\(40-17-RAINBOW\)](#) [CY8CKIT-143A](#) [RASPBERRY PI PICO](#) [EK-](#)
[MPC5744P](#) [KITAURIXTC234TFTTOBO1](#) [ENW89854AXKF](#) [ENWF9201AVEF](#) [QB-R5F104LE-TB](#) [LV18F V6 64-80-PIN TQFP MCU](#)
[CARD EMPTY](#) [LV-24-33 V6 44-PIN TQFP MCU CARD EMPTY](#) [LV-24-33 V6 64-PIN TQFP MCU CARD EMPTY](#) [LV-24-33 V6 80-PIN](#)
[TQFP 1 MCU CARD EMPTY](#) [32X32 RGB LED MATRIX PANEL - 6MM PITCH](#) [3.3 - 5 VTRANSLATOR](#) [READY FOR XMEGA](#)
[CASING \(WHITE\)](#) [RELAY4 BOARD](#) [ETHERNET CONNECTOR](#) [RFID CARD 125KHZ - TAG](#) [RFID READER](#) [RFM12B-DEMO](#)
[MAROON](#) [3G CLICK \(FOR EUROPE AND AUSTRALIA\)](#) [MAX232](#) [MAX3232 BOARD](#) [ARTY S7-50](#) [THREE-AXIS](#)
[ACCELEROMETER BOARD](#) [TINKERKIT HALL SENSOR](#) [TOUCHPANEL](#) [TOUCHPANEL CONTROLLER](#) [MIKROBOARD FOR AVR](#)
[WITH ATMEGA128](#) [MIKROBOARD FOR PSOC WITH CY8C27643](#)