

J-Link Adapters

The following adapters are available for J-Link:

J-Link JTAG Isolator

The J-Link JTAG Isolator can be connected between J-Link and any ARM-board that uses the standard 20-pin JTAG-ARM connector to provide electrical isolation. This is essential when the development tools are not connected to the same ground as the application. It is also useful to protect the development tools from electrical spikes that often occur in some applications, such as motor control applications. Another typical field of application is development of products with sensors or other analog circuitry, in which case the target hardware is protected from electrical noise originating from the development PC. This product is compatible with J-Link, J-Link Pro and Flasher ARM.



J-Link RX Adapter

The J-Link RX Adapter allows JTAG connections between J-Link and target hardware which comes with the Renesas RX600 series MCUs. The J-Link RX adapter is able to optionally power the connected target hardware. 3.3V or 5V supply voltage can be selected using a Jumper. The target is supplied via the VTref connection when the supply option is jumpered.



TCK	1 ●	2	GND
TRSTn	3 ●	4	EMLE
TDO	5 ●	6	---
---	7 ●	8	VTref
TMS	9 ●	10	---
TDI	11 ●	12	GND
nRES	13 ●	14	GND

J-Link 19-pin Cortex-M Adapter

The J-Link 9-pin Cortex-M Adapter allows JTAG, SWD and SWO connections between J-Link and Cortex-M based target hardware systems. It adapts from the 20-pin 0.1" JTAG connector to a 19-pin 0.05" Samtec FTSH connector as defined by ARM.

The J-Link 19-pin Cortex-M Adapter may also be used to connect J-Link to a non Cortex-M target as far as the target connector uses the same pinout as shown below.

By default, TRST is not connected, but the Cortex-M Adapter comes with a solder bridge (NR1) which allows TRST to be connected to pin 9 of the Cortex-M adapter.



VTref	1 ●● 2	SWDIO/TMS
GND	3 ●● 4	SWCLK/TCK
GND	5 ●● 6	SWO/TDO
- - -	7 ● 8	TDI
NC	9 ●● 10	nRESET
5V-Supply	11 ●● 12	TRACECLK
5V-Supply	13 ●● 14	TRACEDATA[0]
GND	15 ●● 16	TRACEDATA[1]
GND	17 ●● 18	TRACEDATA[2]
GND	19 ●● 20	TRACEDATA[3]

J-Link 9-pin Cortex-M Adapter

The J-Link 9-pin Cortex-M Adapter allows JTAG, SWD and SWO connections between J-Link and Cortex-M based target hardware systems. It adapts from the 20-pin 0.1" JTAG connector to a 9-pin 0.05" Samtec FTSH connector as defined by ARM.

The J-Link 9-pin Cortex-M Adapter may also be used to connect J-Link to a non Cortex-M target as far as the target connector uses the same pinout as shown below.

By default, TRST is not connected, but the Cortex-M Adapter comes with a solder bridge (NR1) which allows TRST to be connected to pin 9 of the Cortex-M adapter.



VTref	1 ●● 2	SWDIO/TMS
GND	3 ●● 4	SWCLK/TCK
GND	5 ●● 6	SWO/TDO
- - -	7 ● 8	TDI
NC	9 ●● 10	nRESET

J-Link ARM 14-pin Adapter

This adapter allows to use J-Link with ARM7/9/11 targets using this 14-pin 0.1" mating JTAG connector defined by ARM.

The 14-pin connector, though defined by ARM as an alternative to the 20-pin connector is not widely used on modern eval boards.



VTref	1 ● ● 2	GND
nTRST	3 ● ● 4	GND
TDI	5 ● ● 6	GND
TMS	7 ● ● 8	GND
TCK	9 ● ● 10	GND
TDO	11 ● ● 12	RESET
VTref	13 ● ● 14	GND

J-Link TI 14-pin Adapter

The J-Link TI 14 pin Adapter allows JTAG connections between J-Link and target hardware which use a TI MCU and provides a 14-pin connector (e.g. the BeagleBoard with an OMAP3530 on it), defined by TI. It adapts from the 20-pin 0.1" to a 14-pin 0.1" JTAG connector.



TMS	1 ● ● 2	TRST
TDI	3 ● ● 4	GND
VCCS	5 ● ● 6	NC
TDO	7 ● ● 8	GND
RTCK	9 ● ● 10	GND
TCK	11 ● ● 12	GND
EMU0	13 ● ● 14	EMU1

J-Link 5V JTAG Adapter

The 5V JTAG adapter extends the output voltage range of J-Link to 5V. Most targets have JTAG signals at voltage levels between 1.2V and 3.3V. These targets can be used with J-Link ARM without a 5V adapter. Higher voltages are common primarily in the automotive sector.

Note: Current J-Links are 5V tolerant, but output levels are limited to about 4V (See J-Link specifications for more details).

These output levels are sufficient for most 5V targets, meaning that current J-Links can be used with most 5V targets without adapter. The adapter is only required for 5V targets that require (input) signals above 3.3V.



Technical data:

- 20 pin connector, female (plugs into J-Link)
- 20 pin connector male, for target ribbon cable
- LED shows power status
- Adapter is powered by target
- Power consumption < 20 mA
- Target supply voltage: 3.3V - 5V
- Max. JTAG-frequency: 12 MHz

Compatibility Note

The J-Link ARM 5V JTAG adapter is compatible to J-Link ARM revisions 5 or newer.

Usage

The 5V JTAG adapter should be plugged directly into J-Link ARM with the 20 pin female connector. The target ribbon cable is then attached to the 20 pin male connector of the adapter. The picture below shows a J-Link ARM with a connected 5 volt adapter.

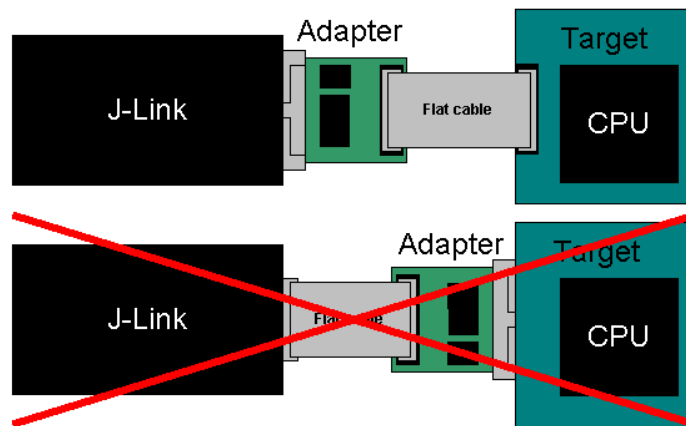

X-ON Electronics

Largest Supplier of Electrical and Electronic Components

Click to view similar products for [Sockets & Adapters](#) category:

Click to view products by [Segger Microcontroller](#) manufacturer:

Other Similar products are found below :

[6508-0-00-01-00-00-33-0](#) [AC164341](#) [AC164348](#) [1262](#) [22827](#) [AC164353](#) [TDGL015](#) [SA247](#) [SM64TQ-ACTEL-1](#) [70-0036](#) [8.06.03](#)
[DS91230+](#) [SMPA-ISP-ACTEL-3-KIT](#) [16017](#) [LFVDBGF](#) [KIT 70601-3](#) [SM132CQ-ACTEL](#) [IPC0181](#) [IPC0175](#) [IPC0165](#) [AC164397](#) [conga-](#)
[Thin MITX/eDP to DP Adapter](#) [ML-ADP-EVN](#) [ASA.01](#) [ASA.09](#) [ASA.12](#) [ASA.14](#) [TOOLSTICK990MPP](#) [MIKROE-425](#) [C305000ACP2](#)
[110-83-320-41-605101](#) [110-83-632-41-605101](#) [110-83-640-41-605101](#) [110-83-628-41-605101](#) [116-83-306-41-001101](#) [PA0003](#) [PA0007](#)
[PA0009](#) [PA0035](#) [PA0085](#) [PA0096](#) [IPC0079](#) [ATARD-DBGADPT](#) [80-000286](#) [ATSTK600-RC26](#) [ATSTK600-RC46](#) [ATSTK600-RC88](#)
[ATSTK600-SC06](#) [ATSTK600-RC78](#) [SPC560PADPT64S](#)