

Messrs.

(first · revised)

Delivery SpecificationsProduct No : Quartz Crystal Unit SP-T2A-FItem code : Q-SPT2S0327620C5DJProduct form : 32.768kHz \pm 20 \times 10⁻⁶ / 12.5pFThe number of copies : copies (copies return to us)Date of Registrantion :

Receipt Column	Note

NOTICE

1. Advance agreement will be needed before changing any contents of the specification herein.
2. Provided that the information herein is subject to change, only revised pages shall be reissued.
3. When the product described herein includes Regulated Products subject The Wassenaar Arrangement etc, they may not be exported without authorization form the appropriate governmental authorities.
4. The contents of this specification including all figures and illustrations are proprietary information (copyright or know-how) of Seiko Instruments Inc. It is strictly prohibited to copy all or part of these specifications to third parties without permission.
5. In the case that the products described herein are used as part of any devices or equipment which might influence any one of the human body, human life and property, such as physical exercise equipment, medical equipment or vehicles, please let us know that.

Seiko Instruments Inc.
 Quartz Crystal Division
 Network Components Business

1-8, Nakase, Mihamaku, Chiba shi,
 Chiba 261-8507 Japan

Dept. of Issue

Sales Section

Dept. of Control

Quality Assurance Section

Delivery Specifications

1.Scope

These specifications apply to QUARTZ CRYSTAL RESONATORS (hereinafter referred to as RESONATORS) to be manufactured by Seiko Instruments Inc. (hereinafter referred to as SII) to _____

2.Designation

RESONATORS are designated " SP-T2A-F"(32.768kHz).

3.Shape and dimensions

As per the SP-T2A-F drawing shown on page 5 .

4.Electrical characteristics

Specified on page 2 through 3.

5.Shipment and packaging

5.1 (3,000) pcs are the standard lot size to which the lot number shall be allotted

5.2 The packaging shall conform to the resonator packaging standards.

6.Outgoing inspection

6.1 When mutually agreed, the outgoing inspection shall be conducted as per the standard on page 4.

6.2 The outgoing inspection slip is not basically affixed to each packaging.

7.Warranty

In the event that any defective RESONATORS or defective lot is found at incoming inspection at _____ and that any defect resulting from failures in process-control at SII after incoming inspection is found, good RESONATORS shall be supplied to _____ free of charge as a replacement .

In the event that any trouble or problems rising directly from RESONATORS occurs, it will be amicably settled between both parties, provided that warranty shall be done within the score of replacement of good RESONATORS.

8.Amendment or abolition of the specifications

Amendment or abolition of the specifications shall be made upon mutual consent between _____ and SII. If any problem arises , it shall be amicably settled between both parties.

9.Effectiveness of the specifications

These specifications are effective after receipt of returned copies with your approved sign.

10.Ohters

RoHS compliant

These products use Pb in high melting temperature type solders exempted by RoHS directive.

[1] The maximum rating

	Item	Symbol	Rating	Note
1	Storage temperature range	T_stg	-55 ~ +125	
2	Maximum drive level	DL max.	1.0 μ W max.	

[2] Recommended Operating Condition

	Item	Symbol	Rating	Note
1	Operating temperature range	T_use	-40 ~ +85	
2	Drive level	DL	0.1 μ W typ.	

[3] Electrical -CharacteristicsMeasurement temperature : 25 \pm 2

	Item	Symbol	Specifications	Conditions
1	Nominal frequency	f_nom	32.768 kHz	
2	Frequency tolerance	f_tol	$\pm 20 \times 10^{-6}$	
3	Load capacitance	C _L	12.5 pF	
4	Motional resistance	R ₁	50 k Ω max.	Measured with ATI 4192A Impedance analyzer. OSC LEVEL = 0.1V
5	Q-value	Q	40×10^3 min.	calculated with the following equation : $Q=(2\pi \cdot Fr \cdot L_1)/R_1$
6	Motional capacitance	C ₁	2.2 fF typ.	
7	Shunt capacitance	C ₀	1.0 pF typ.	Measured with ATI 4192A Impedance analyzer. OSC LEVEL = 0.1V
8	Turnover temperature	Ti	25 \pm 5	Measure this coefficient at 3 points of 10 , 25 , and 40 using C-MOS circuit.
9	Parabolic coefficient	B	$(-3.5\pm 0.8) \times 10^{-8} / ^2$	
10	Frequency ageing	f_age	$\pm 5 \times 10^{-6} / \text{year}$	25 \pm 3 , First year
11	Insulation resistance	IR	500 M Ω min.	Measured with ATI 4329A Insulation Resistance Meter. Apply DC100V.

[4] Environment-proof · Mechanical property

No	Item	Specifications	Conditions	
1	High temperature storage	$f/f = \pm 5 \times 10^{-6}$	After storage under 85 for 500 hrs, measure at room temperature.	*1
2	Low temperature storage	$f/f = \pm 5 \times 10^{-6}$	After storage under -40 for 500 hrs, measure at room temperature.	*1
3	High temperature and high humidity storage	$f/f = \pm 5 \times 10^{-6}$	After storage under 60 ± 2 , 90 to 95% RH for 500 hrs, measure at room temperature.	*1
4	Thermal shock resistance	$f/f = \pm 5 \times 10^{-6}$	Measured at room temperature after 20 cycles. -25 +80 for 30 minutes.	*1
5	Mechanical shock resistance	$f/f = \pm 5 \times 10^{-6}$	Measure after free drop of the RESONATOR three times from the height of 75cm onto a wooden board.	*2
6	Vibration resistance	$f/f = \pm 5 \times 10^{-6}$	Amplitude 1.5mm and 10 ~ 60Hz with cycle time 2 ~ 3 minutes in 3 direction (X,Y,and Z axis)each for 2 hrs.	*2
7	IR Reflow	$f/f = \pm 10 \times 10^{-6}$	Measure after 1 time reflow under reflow profile specified in page 10	*1

Note:

1. The above tests no. 1 to 7 must be conducted independently (not series tests)
2. *1: Measure after 24 hours soak at room temperature .
3. *2: Measure after 2 hours soak at room temperature .
4. R1 is 70kΩ max. after the each above tests.

[5] Precautions

(1) Recommended mounting conditions

Reflow profile As per reflow profile shown in page 10.
 Manual soldering 350 max. for 4 sec. max.

(2) Cleaning

The crystal resonator may be destroyed by ultrasonic cleaning.

We don't guarantee the quality of the product with that cleaning method because such conditions as type of the washing machine, power, time, position in the bath, etc. can not be specified.

Please confirm ultrasonic cleaning is not giving any damage to the product before use when that cleaning method must be used.

[6] Outgoing inspection standard

· The outgoing inspection shall be conducted as per the following standard .

· The sampling shall be performed according to the ANSI/ASQCZ1.4-1996 .

No	Item	Sampling level	AQL(%)
1	Frequency tolerance		1.0
2	Equivalent series resistance		1.0
3	Outer appearance		1.5
4	Others characteristics	Periodical quality inspection	

[7] Out Line Drawing

1. Mechanical dimensions

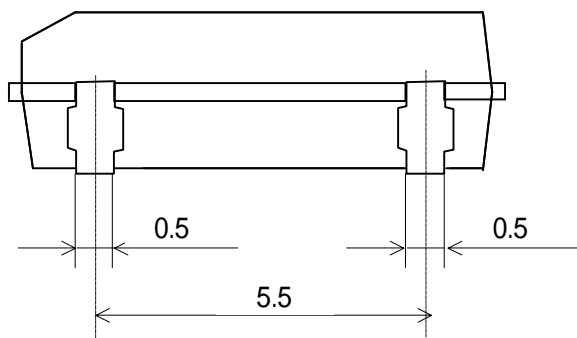
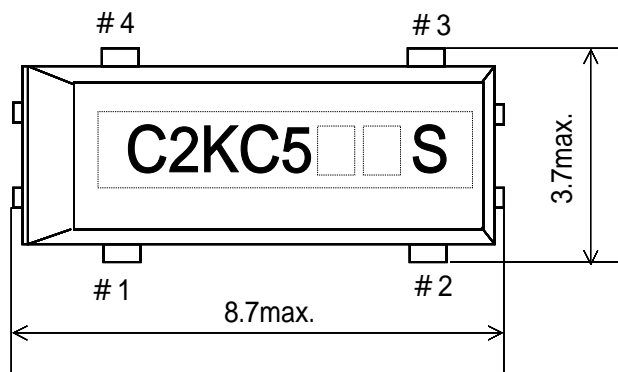

2. Marking

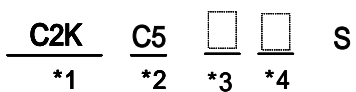

*1 Frequency

*2 Specification

*3 Mfg. Year
Last digit of year

*4 Mfg. Month
Jan. ~ Dec. : A ~ M
(excluding I)

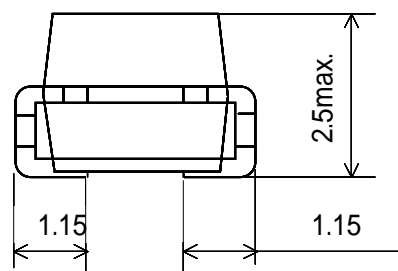

3. Lead connection

Do not connect Terminals #2, #3 to the outside electrode. These are dummy terminals.

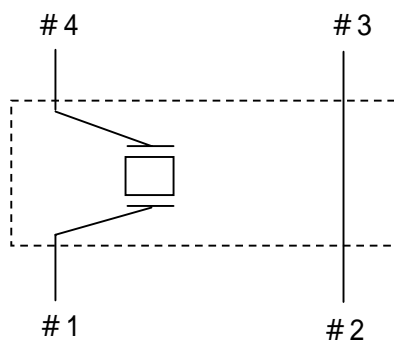

4. Recommendation soldering pattern figure.

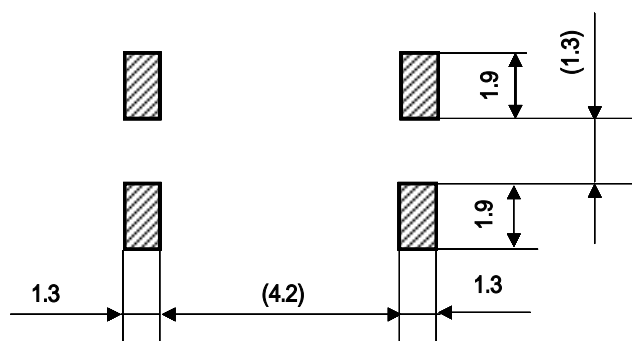

Materials 42 Alloy
Sn (100%)

Remarks

Unit
1 = 1mm

[8] Taping specification

1 . Drawing of tape dimensions

Carrier tape see Drawing No. 8/11

Reel for carrier tape see Drawing No. 9/11

2 . Material

Carrier tape : Polystyrene

Reel for carrier tape : HIPS

3 . Taping method

- (1) Taping shall be placed in tapes in such manner as to assure that marking of the components is visible as per Fig. 1

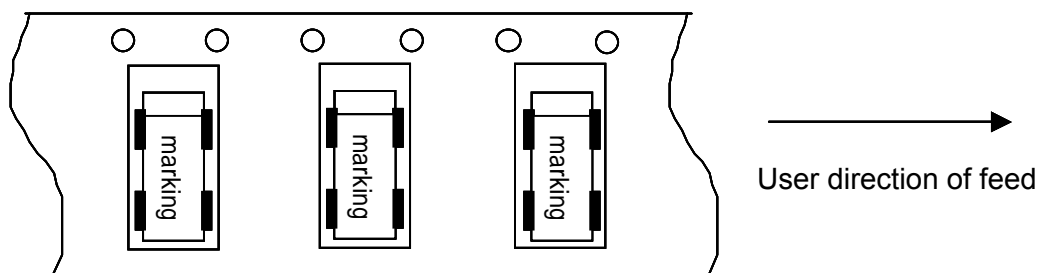

Fig. 1

- (2) Reel

On the side of reel there shall be more than 20 blocks of "No components".
The beginning of Carrier Tape shall be bent vertically and hooked on groove of reel.

- (3) Leader

On the side of leader, there shall be more than 20 blocks of "No components".
The length of Leader shall be over 400 mm.
The Length of Stick Tape for Cover Tape shall be about 100 mm and
Stick Tape shall never be detached.

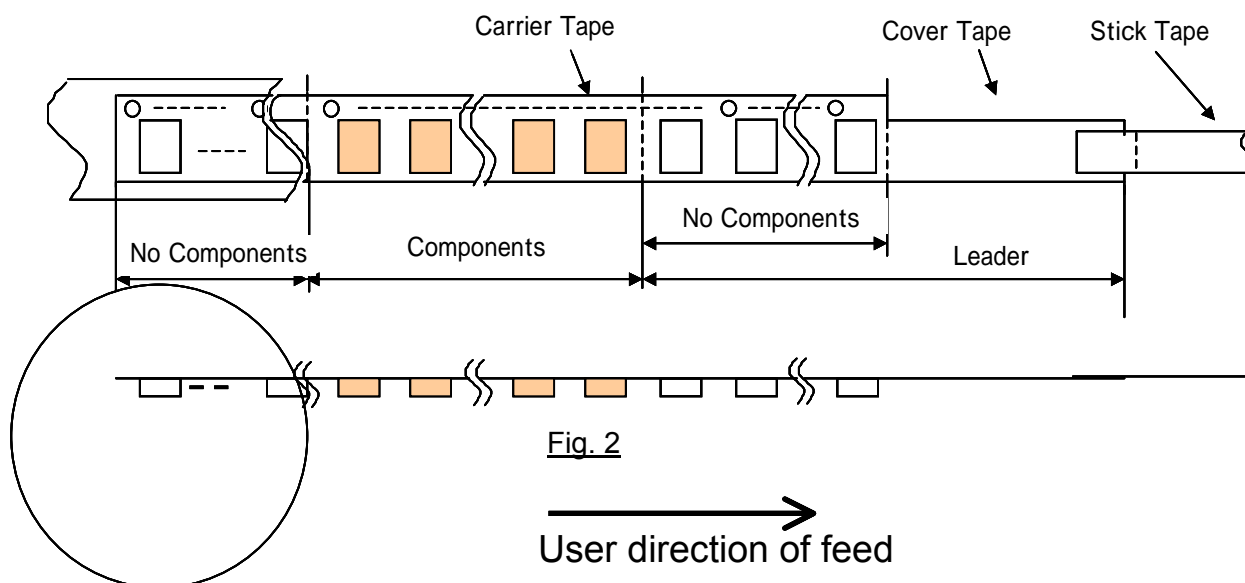
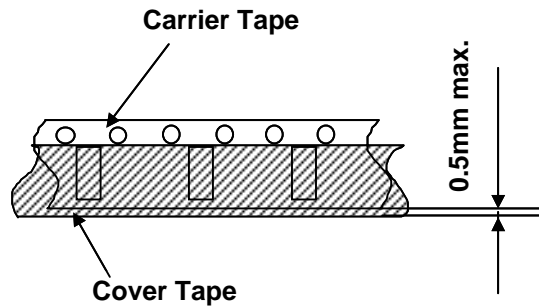

Fig. 2

- (4) Gap between Carrier Tape and Cover Tape
Cover Tape protrudes from Carrier Tape by 0.5mm max.

Fig. 3



Holes of Carrier Tape are covered with Cover Tape by 0.75mm max.

Fig. 4

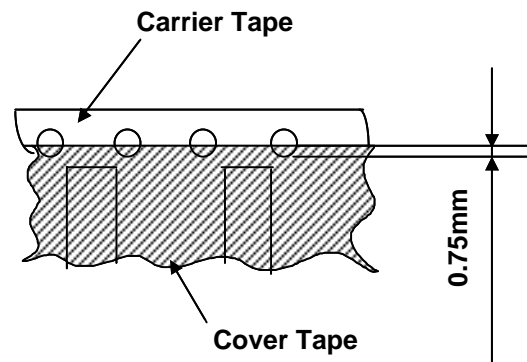

- (5) Peel strength

The method of testing is done as shown below.

The value of force is at the beginning of desealing.

The Cover Tape peel forth shall be 0.1 ~ 1.3N at a peel speed of 300 ± 10 mm/min.

Fig. 5

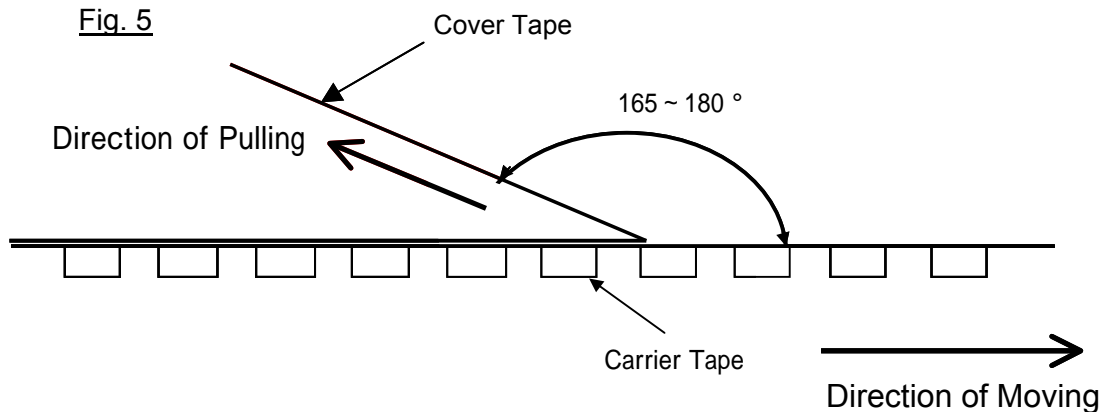

Carrier tape

- (1) Conforms with EIA-481
- (2) Tolerance ± 0.2

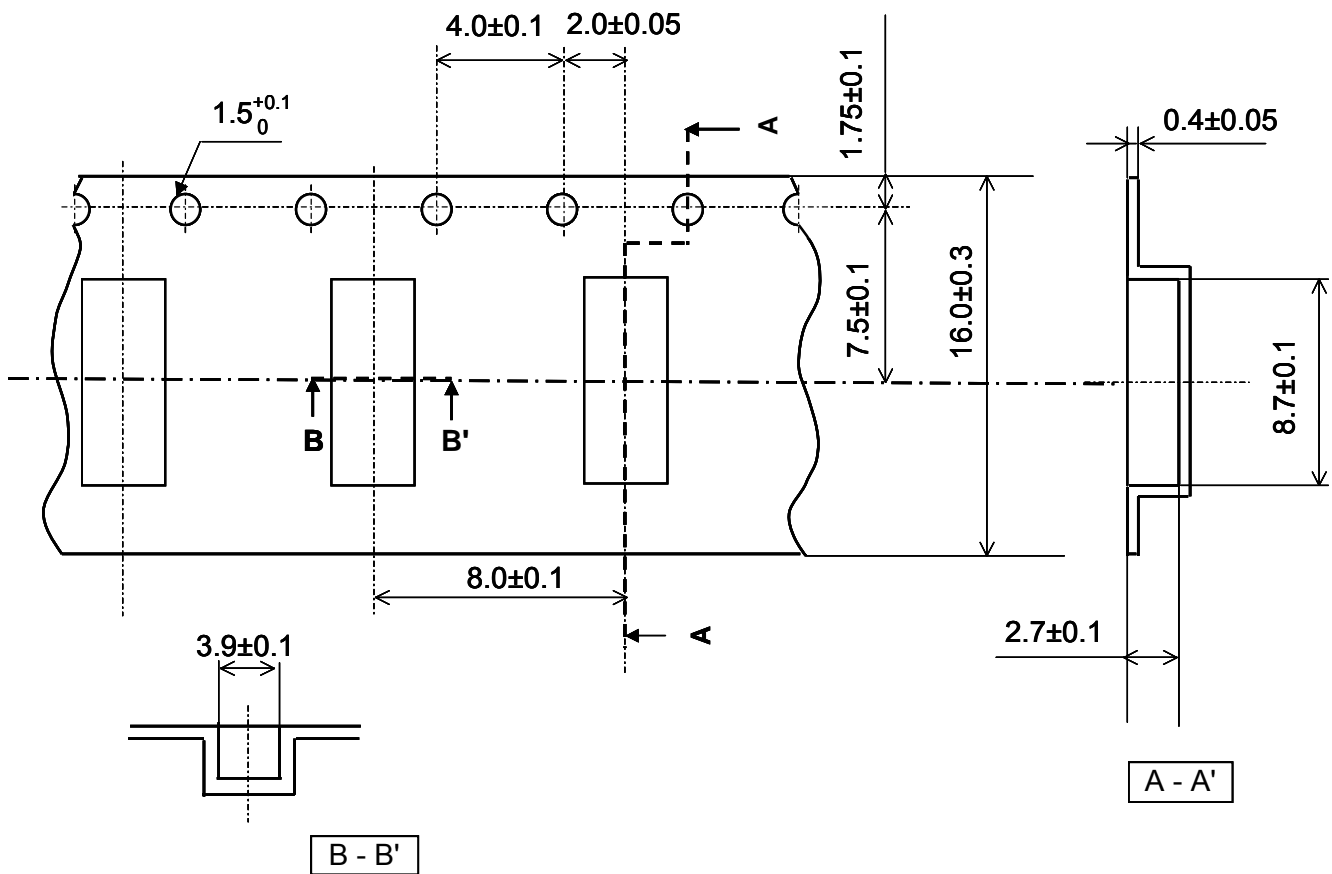

Unit=mm

Taping reel

- (1) Conforms with EIAJ ET-7200B
- (2) Quantity per reel : 3,000pcs./ for a reel

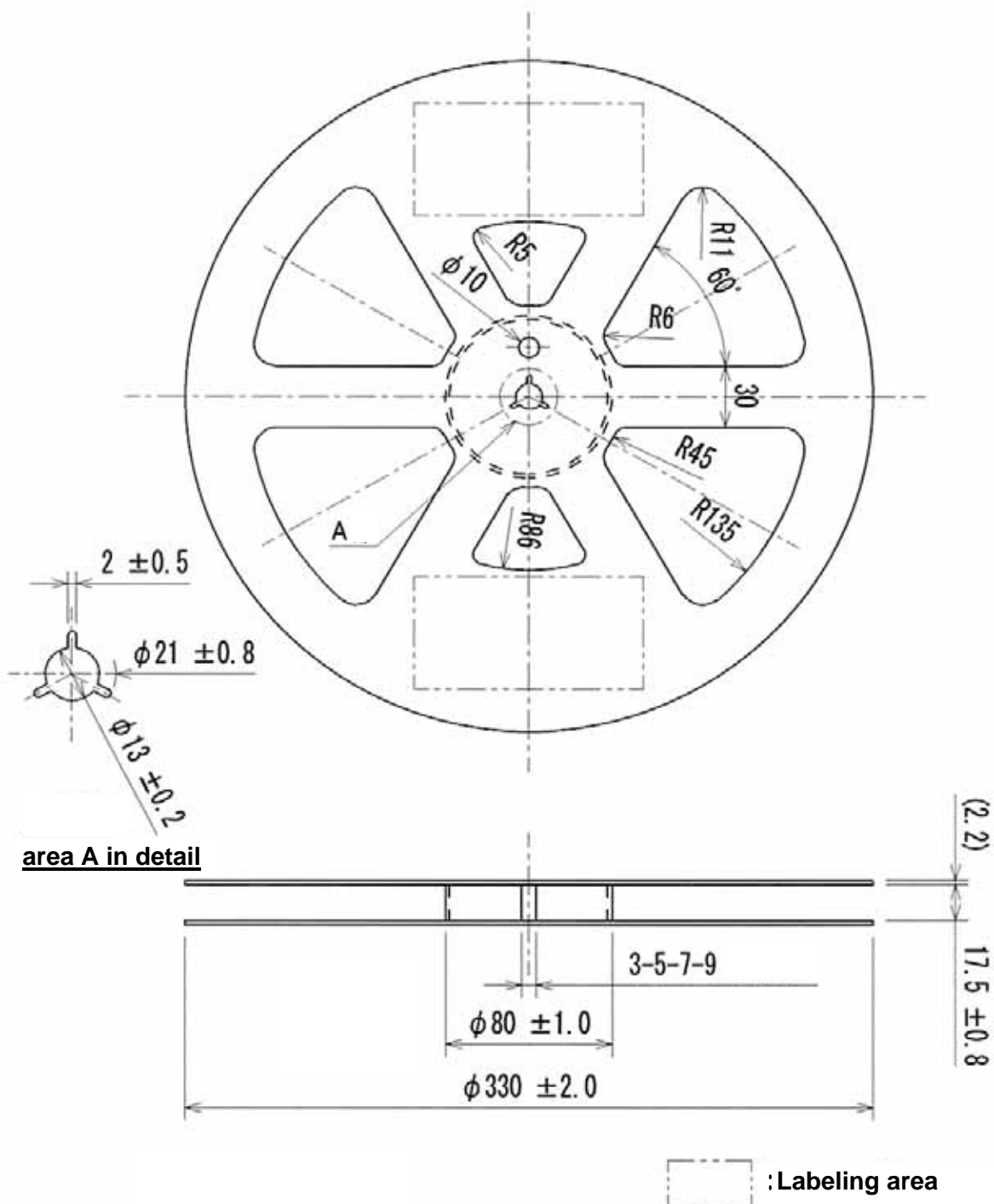

Unit : mm

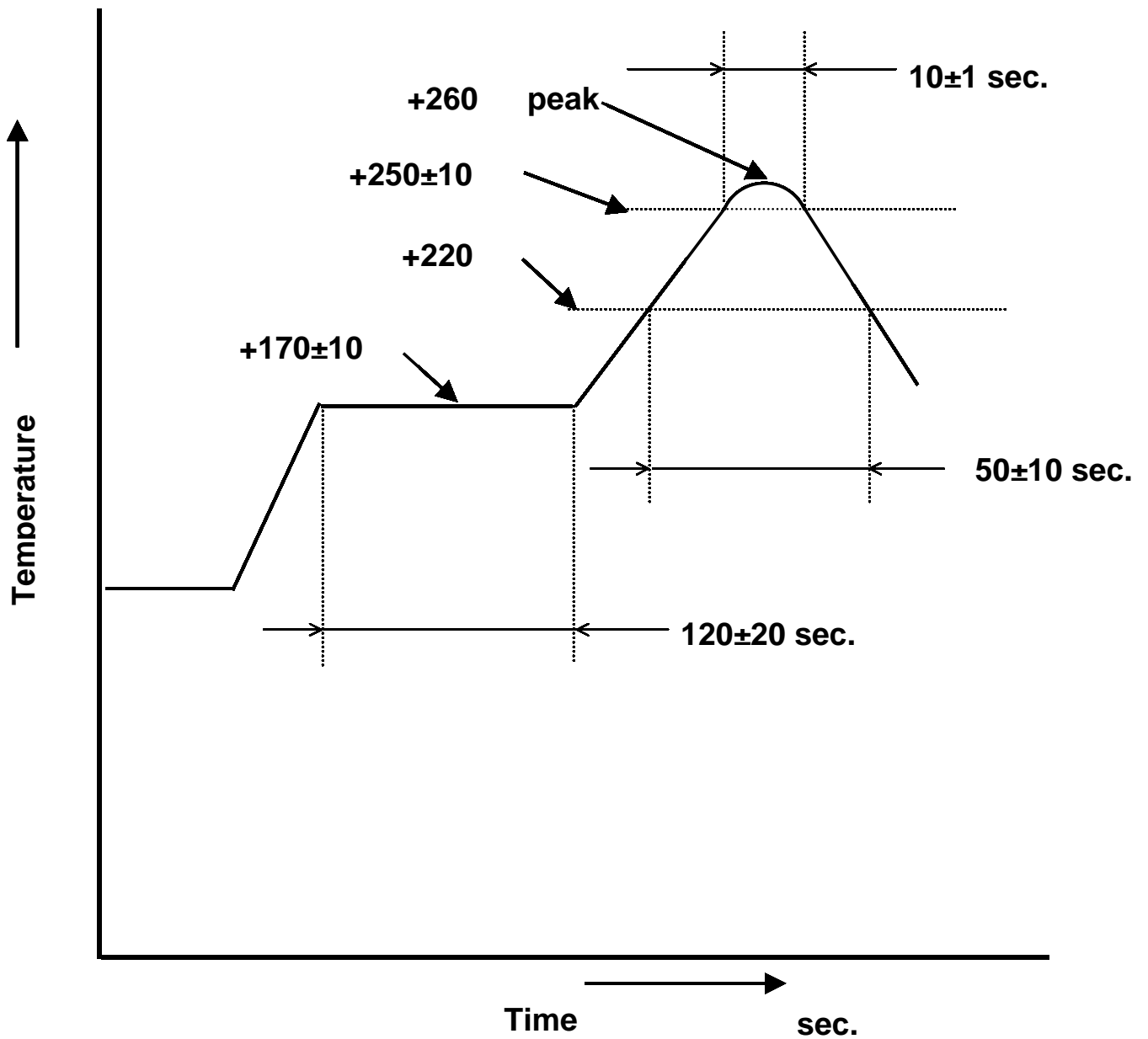
[9]Reflow Profile

Note: The temperature used herein means the temperature on the circuit board.

Reflow : 2 times max.

[10] Outside box packing specification

- (1) To attach the label every 1 volume of reel.
- (2) To insert it in the corner bottom Polyethylene bag.

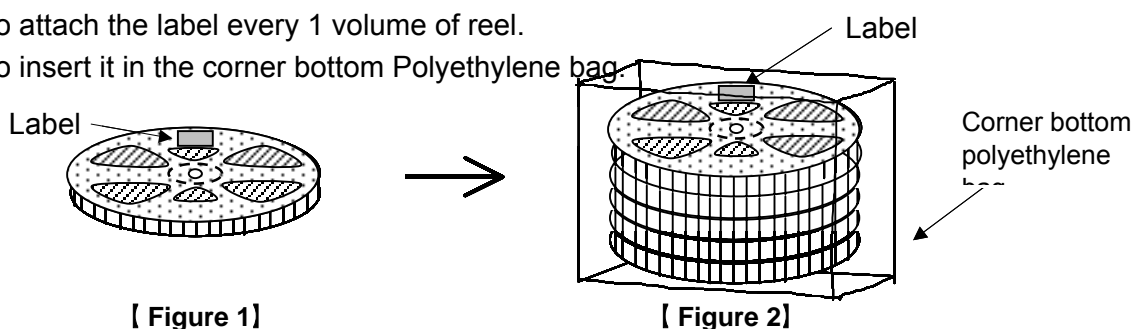

[Figure 1]

[Figure 2]

- (3) Box size and reels

Outside Box	K2	K1	G2M	T1
Maximum reels	4	10	15	20

- (4) An outer case packing structure (the sectional plan)

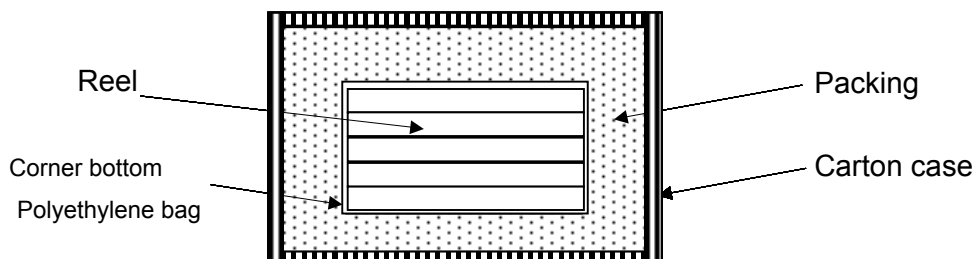

[Figure 3]

- (5) Storage quantity
·It makes N=3 , 000 pieces/Lot

- (6) Sample of the label display (display department, please refer to [Figure 1] [Figure 2])

Product bar code	PART	SP-T2A-F	PART	: Our company product name
	Lot No.		Lot No.	: Lot No. display
Item bar code *	Quantity	3 , 000 pcs	Quantity	: Quantity
	Calibre	32.768kHz 12.5pF/ ± 20 × 10 ⁻⁶	Calibre	: Frequency, CL value, F0 deviation
Quantity Lot. No. bar code 3,000 XXXX	Remarks		Remarks:	Marking etc. * : Item code

- (7) Storage environment

A product avoids the direct ray and please store with the normal temperature and humidity .
(Conformance in JIS Z8703 Standard Atmospheric Conditions for Testing.)

- * Normal temperature range : 5 to 35
- * Normal relative humidity range : 45 to 85%

X-ON Electronics

Largest Supplier of Electrical and Electronic Components

Click to view similar products for [seiko manufacturer](#):

Other Similar products are found below :

[CVR-B01-1-E](#) [PW-0903H-W2-E](#) [PW-C0725-W1-A](#) [DPU-S445-BLUETOOTH](#) [IF2202-02B](#) [IFC-001K](#) [CAPM347B-E](#) [SLP-1RLB](#) [PW-C0725-W1-K](#) [LTP9247B-C448-E](#) [401-PLATEN](#) [IF2301-01B](#) [IF3002-01B](#) [KPU-S447S-11H-E](#) [DPU-D3-00A-E](#) [DPU-S445-01A-E](#) [X1G004481003100](#) [X1E0000210477](#) [SG-8018CE-29.500000MHz-TJHPA](#) [SG-8018CB-55.296000MHz-TJHSA](#) [SG-8018CB-48.000000MHz-TJHPA](#) [SG-8018CE-10.485760MHz-TJHPA](#) [SG-8018CB-33.000000MHz-TJHPA](#) [SG-8018CB-33.300000MHz-TJHPA](#) [SG-8018CB-40.000000MHz-TJHPA](#) [SG-8018CE-54.000000MHz-TJHSA](#) [SG-8002CA-10.000000MHz-PCM](#) [SG-8002CA-62.500000MHz-PCM](#) [X1G004281001111](#) [X1G004261012611](#) [X1G004281010311](#) [X1G004261012011](#) [SG-9101CA 32.768MHz D05PHAAA](#) [SG-9101CE 20.000MHz C20PHAAA](#) [SG-9101CG 50.000MHz C05PHAAA](#) [SLP-TRAY650](#) [RP-B10-U11JW1-03](#) [APU-9247-C01P-E](#) [CAPD347A-E](#) [RP-E11-K3FJ1-U1C3](#) [RP-E10-K3FJ1-U1C3](#) [ACU2324C-A-E](#) [SG-8018CG-106.666666MHz-TJHPA](#) [SG-8018CB-29.971000MHz-TJHPA](#) [SG-8002CA-14.745600MHz-PHM](#) [SG-8002CA-65.000000MHz-PCM](#) [X1G004261003111](#) [SG-9101CE 12.000000MHz C20PHAAA](#) [DPU-V445-10B-E](#) [CAPG247A-E](#)