

# 1SS355-BL

## Silicon Epitaxial Planar Switching Diode

### Features

- Small plastic package suitable for surface mounted design
- High reliability with high surge current handling capability

### Applications

- High speed switching

### PINNING

PIN	DESCRIPTION
1	Cathode
2	Anode

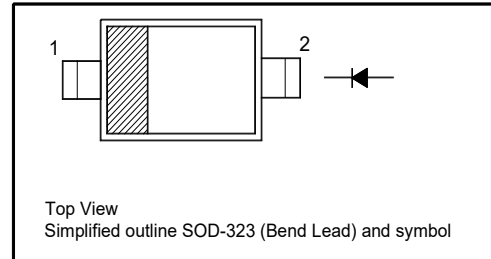

### Absolute Maximum Ratings ( $T_a = 25^\circ\text{C}$ )

Parameter	Symbol	Value	Unit
Peak Reverse Voltage	$V_{RM}$	90	V
Reverse Voltage	$V_R$	80	V
Average Rectified Forward Current	$I_{F(AV)}$	100	mA
Peak Forward Current	$I_{FM}$	225	mA
Surge Forward Current (1 s)	$I_{FSM}$	500	mA
Power Dissipation	$P_D$	200	mW
Junction Temperature	$T_j$	150	$^\circ\text{C}$
Storage Temperature Range	$T_{stg}$	- 55 to + 150	$^\circ\text{C}$

### Thermal Characteristics

Parameter	Symbol	Max.	Unit
Thermal Resistance from Junction to Ambient <sup>1)</sup>	$R_{\theta JA}$	625	$^\circ\text{C/W}$

<sup>1)</sup> Device mounted on FR-4 substrate PC board, 2oz copper, with minimum recommended pad layout.

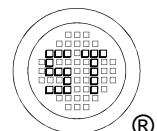

# 1SS355-BL

---

## Electrical Characteristics ( $T_a = 25^\circ\text{C}$ )

Parameter	Symbol	Min.	Max.	Unit
Reverse Breakdown Voltage at $I_R = 100 \mu\text{A}$	$V_{(BR)R}$	80	-	V
Forward Voltage at $I_F = 100 \text{ mA}$	$V_F$	-	1.2	V
Reverse Current at $V_R = 80 \text{ V}$	$I_R$	-	100	nA
Capacitance between Terminals at $V_R = 0.5 \text{ V}$ , $f = 1 \text{ MHz}$	$C_T$	-	3	pF
Reverse Recovery Time at $I_F = 10 \text{ mA}$ , $I_{rr} = 0.1 \times I_R$ , $V_R = 6 \text{ V}$ , $R_L = 100 \Omega$	$t_{rr}$	-	4	ns

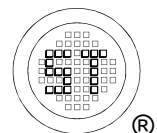

## Electrical Characteristics Curves

Fig 1. Power Derating Curve

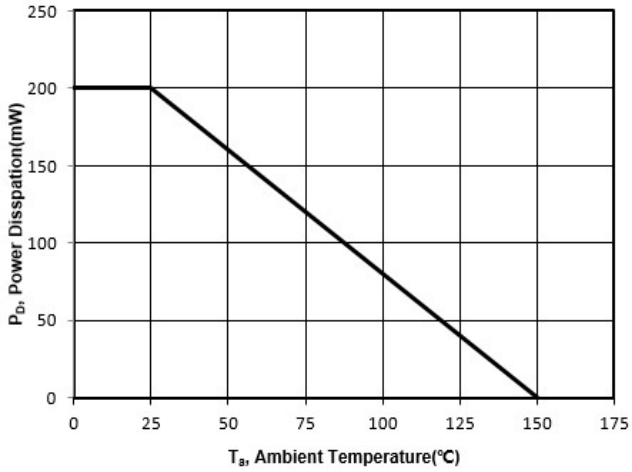

Fig 2. Total Capacitance vs. Reverse Voltage

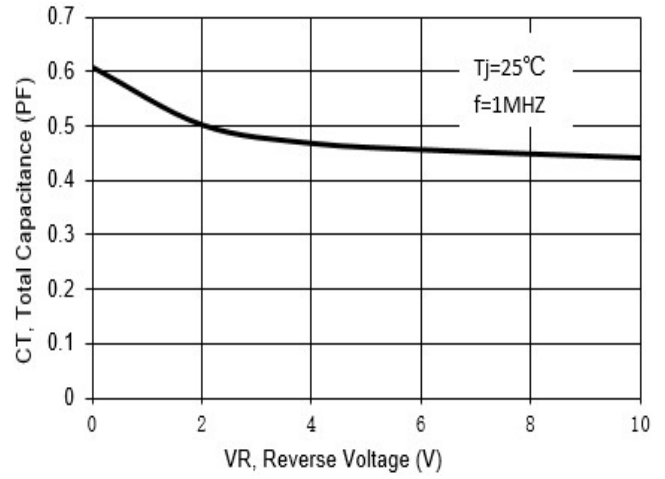

Fig 3. Reverse Current vs. Reverse Voltage

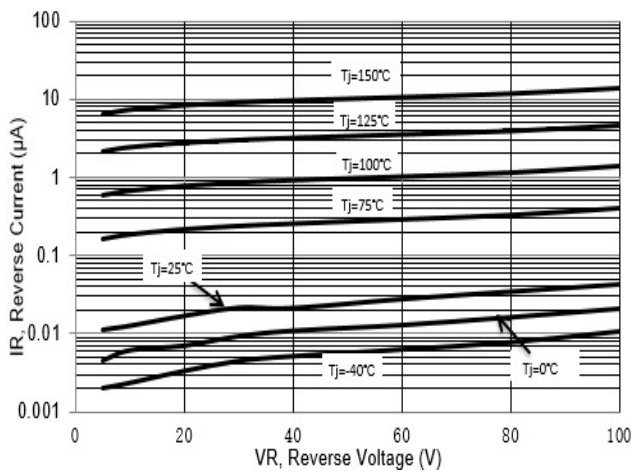
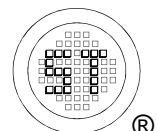
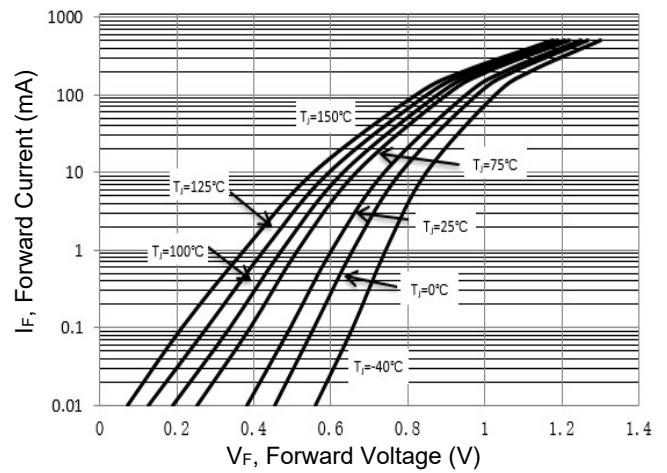

Fig 4. Forward Characteristics



# 1SS355-BL

## PACKAGE OUTLINE

Plastic surface mounted package; 2 leads

SOD-323BL

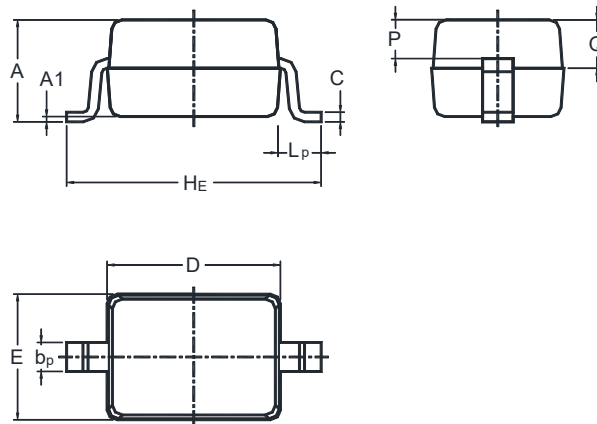

UNIT	A	A <sub>1</sub>	b <sub>P</sub>	C	D	E	H <sub>E</sub>	L <sub>P</sub>	Q	P
mm	1.1 0.8	0.1 0	0.4 0.25	0.18 0.09	1.8 1.6	1.35 1.15	2.8 2.3	0.5 0.1	0.5 0.3	0.4 0.3

### Recommended Soldering Footprint

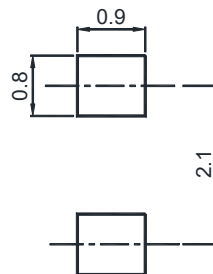

### Packing information

Package	Tape Width (mm)	Pitch		Reel Size		Per Reel Packing Quantity
		mm	inch	mm	inch	
SOD-323BL	8	4 ± 0.1	0.157 ± 0.004	178	7	3,000

### Marking information

" W2 " = Part No.

" III " = Cathode line

Font type: Arial

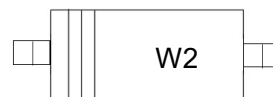

Disclaimer: Our company reserve the right to make modifications, enhancements, improvements, corrections or other changes to improve product design, functions and reliability, anytime without notice. Semtech Electronics Limited makes no warranties, representations or warranties regarding the suitability of its products for any particular purpose, and does not accept any liability arising from the application or use of any product or circuit such as: Apply to medical, military, aircraft, space or life support equipment and expressly waive any and all liability, including but not limited to special, consequential or collateral damage.

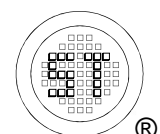

## X-ON Electronics

Largest Supplier of Electrical and Electronic Components

*Click to view similar products for* [Diodes - General Purpose, Power, Switching category:](#)

*Click to view products by* [Semtech manufacturer:](#)

Other Similar products are found below :

[MCL4151-TR3](#) [MMBD3004S-13-F](#) [RD0306T-H](#) [1N3611](#) [NTE156A](#) [NTE574](#) [NTE6244](#) [1SS193,LF](#) [1SS400CST2RA](#) [SDAA13](#)  
[SHN2D02FUTW1T1G](#) [LS4151GS08](#) [1N4449](#) [1N456A](#) [1N4934-E3/73](#) [1N914BTR](#) [RFUH20TB3S](#) [D291S45T](#) [BAV300-TR](#) [BAW56DWQ-](#)  
[7-F](#) [BAW56M3T5G](#) [BAW75-TAP](#) [MM230L-CAA](#) [IDW40E65D1](#) [JAN1N3600](#) [JAN1N4454UR-1](#) [LL4151-GS18](#) [SMMSD4148T3G](#)  
[BYW95B/A52A](#) [NSVDAN222T1G](#) [CDSZC01100-HF](#) [LL4150-M-08](#) [1N4454-TR](#) [BAV70HDW-7](#) [BAS28-7](#) [JANTX1N6640](#) [BAW56HDW-](#)  
[13](#) [BAS28 TR](#) [VS-HFA04SD60STR-M3](#) [NSVM1MA152WKT1G](#) [1SS388-TP](#) [RGP30D-E3/73](#) [VS-8EWF02S-M3](#) [BAV99TQ-13-F](#)  
[BAV99HDW-13](#) [MMDB30-E28X](#) [IDP20C65D2XKSA1](#) [LS4148](#) [IDV15E65D2](#) [NSVM1MA152WAT1G](#)