

BAV19WS, BAV20WS, BAV21WS

Silicon Epitaxial Planar Diodes

High Voltage Switching Diode

Features

- Fast switching speed
- Surface mount package ideally suited for automatic insertion

PINNING

PIN	DESCRIPTION
1	Cathode
2	Anode

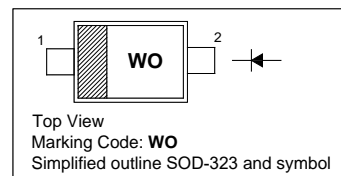

Absolute Maximum Ratings ($T_a = 25\text{ }^\circ\text{C}$)

Parameter	Symbol	Value	Unit
Repetitive Peak Reverse Voltage	BAV19WS BAV20WS BAV21WS V_{RRM}	120 200 250	V
Reverse Voltage	BAV19WS BAV20WS BAV21WS V_R	100 150 200	V
Average Rectified Forward Current	$I_{F(AV)}$	200	mA
Forward Continuous Current	I_{FM}	400	mA
Repetitive Peak Forward Current	I_{FRM}	625	mA
Non-Repetitive Peak Forward Surge Current	at $t = 1\text{ }\mu\text{s}$ at $t = 1\text{ s}$ I_{FSM}	2.5 0.5	A
Power Dissipation	P_{tot}	200	mW
Operating and Storage Temperature Range	T_j, T_{stg}	- 65 to + 150	$^\circ\text{C}$

Characteristics at $T_a = 25\text{ }^\circ\text{C}$

Parameter	Symbol	Min.	Max.	Unit
Reverse Breakdown Voltage at $I_R = 100\text{ }\mu\text{A}$	BAV19WS BAV20WS BAV21WS $V_{(BR)R}$	120 200 250	- - -	V
Reverse Current at $V_R = 100\text{ V}$ at $V_R = 150\text{ V}$ at $V_R = 200\text{ V}$	BAV19WS BAV20WS BAV21WS I_R	- - -	100 100 100	nA
Forward Voltage at $I_F = 100\text{ mA}$ at $I_F = 200\text{ mA}$	V_F	- -	1 1.25	V
Total Capacitance at $V_R = 0, f = 1\text{ MHz}$	C_T	-	5	pF
Reverse Recovery Time at $I_F = I_R = 30\text{ mA}, I_{RR} = 0.1 \times I_R, R_L = 100\text{ }\Omega$	t_{rr}	-	50	ns

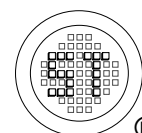

BAV19WS, BAV20WS, BAV21WS

Electrical Characteristics Curves

Fig 1. V_R characteristics

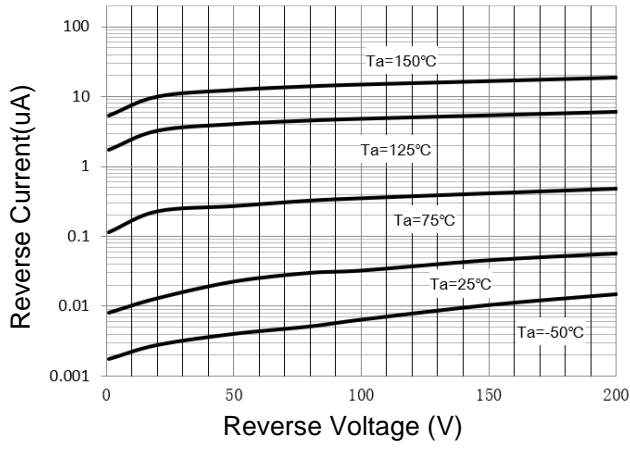

Fig 2. V_F characteristics

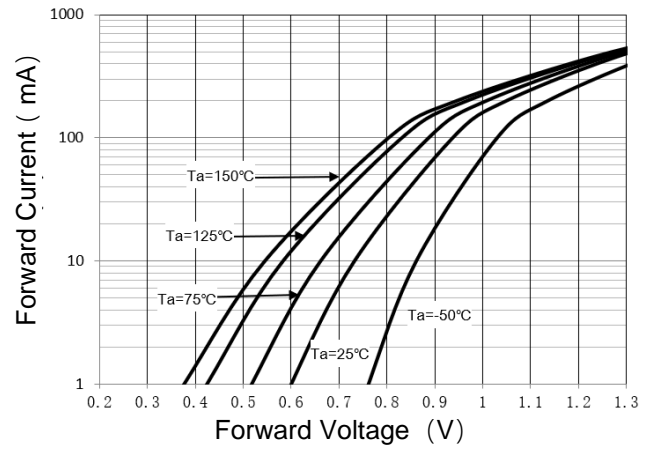

Fig 3. IFSM Curve

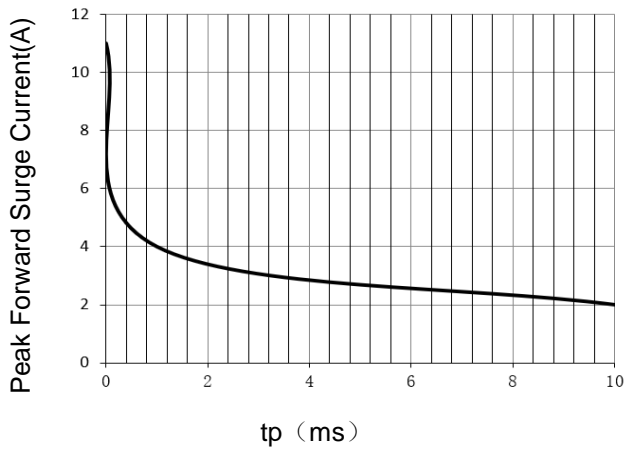
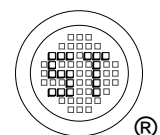
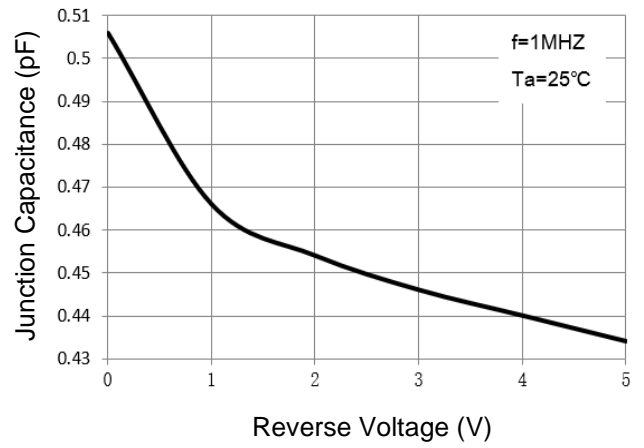

Fig 4. Junction Capacitance



BAV19WS, BAV20WS, BAV21WS

PACKAGE OUTLINE

Plastic surface mounted package; 2 leads

SOD-323

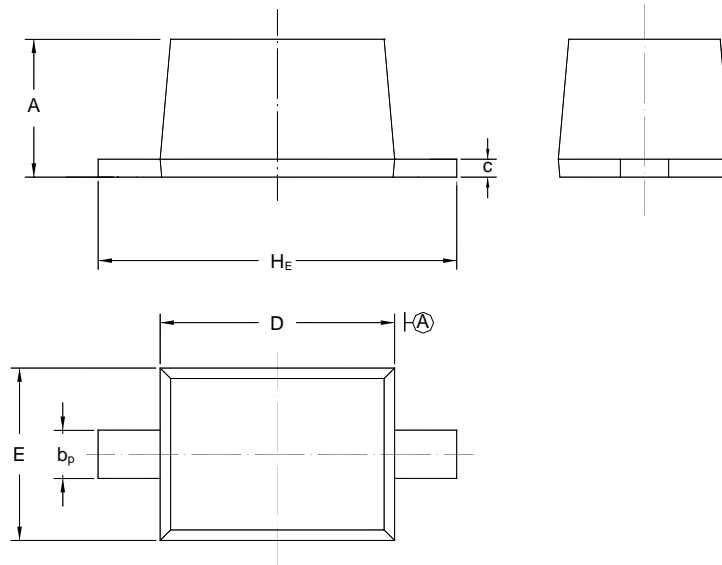

UNIT	A	b _p	C	D	E	H _E
mm	1.10 0.80	0.40 0.25	0.15 0.10	1.80 1.60	1.35 1.15	2.80 2.30

Recommended Soldering Footprint

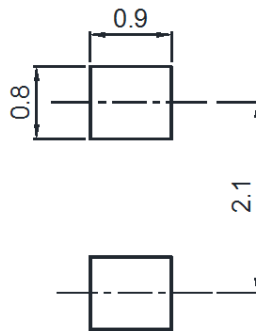

Packing information

Package	Tape Width (mm)	Pitch		Reel Size		Per Reel Packing Quantity
		mm	inch	mm	inch	
SOD-323	8	4 ± 0.1	0.157 ± 0.004	178	7	3,000

Marking information

" III " = Cathode line

" WO " = Part No.

Font type: Arial

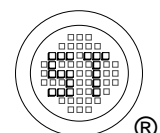
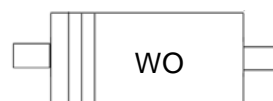

X-ON Electronics

Largest Supplier of Electrical and Electronic Components

Click to view similar products for [Diodes - General Purpose, Power, Switching category](#):

Click to view products by [Semtech manufacturer](#):

Other Similar products are found below :

[MCL4151-TR3](#) [MMBD3004S-13-F](#) [RD0306T-H](#) [1N3611](#) [NTE156A](#) [NTE574](#) [NTE6244](#) [1SS193,LF](#) [1SS400CST2RA](#) [SDAA13](#)
[SHN2D02FUTW1T1G](#) [LS4151GS08](#) [1N4449](#) [1N456A](#) [1N4934-E3/73](#) [1N914BTR](#) [RFUH20TB3S](#) [D291S45T](#) [BAV300-TR](#) [BAW56DWQ-](#)
[7-F](#) [BAW56M3T5G](#) [BAW75-TAP](#) [MM230L-CAA](#) [IDW40E65D1](#) [JAN1N3600](#) [JAN1N4454UR-1](#) [LL4151-GS18](#) [SMMSD4148T3G](#)
[BYW95B/A52A](#) [NSVDAN222T1G](#) [CDSZC01100-HF](#) [LL4150-M-08](#) [1N4454-TR](#) [BAV70HDW-7](#) [BAS28-7](#) [JANTX1N6640](#) [BAW56HDW-](#)
[13](#) [BAS28 TR](#) [VS-HFA04SD60STR-M3](#) [NSVM1MA152WKT1G](#) [1SS388-TP](#) [RGP30D-E3/73](#) [VS-8EWF02S-M3](#) [BAV99TQ-13-F](#)
[BAV99HDW-13](#) [MMDB30-E28X](#) [IDP20C65D2XKSA1](#) [LS4148](#) [IDV15E65D2](#) [NSVM1MA152WAT1G](#)