

PROTECTION PRODUCTS

Description

The EClamp®2357NQ is a low pass filter array with integrated TVS diodes. It is designed to suppress unwanted EMI/RFI signals and provide electrostatic discharge (ESD) protection in portable electronic equipment. They have been optimized for protection of touch screen displays, secure digital (SD) card interfaces, and color LCD panels in cellular phones and other portable electronics.

The device consists of six π filter circuits comprised of TVS diodes for ESD protection, and a resistor capacitor network for EMI/RFI filtering. A series resistor value of 100 Ω and a component capacitance value of 10pF are used to achieve 20dB minimum attenuation from 1.0GHz to 3GHz. The device also includes 4 discrete TVS diodes for dedicated ESD protection. All of the TVS diodes provide effective suppression of ESD voltages in excess of ± 20 kV (air discharge) and ± 12 kV (contact discharge) per IEC 61000-4-2, level 4.

The EClamp2357NQ is qualified to AEC-Q100 Grade 1 for automotive use.

Package Dimensions

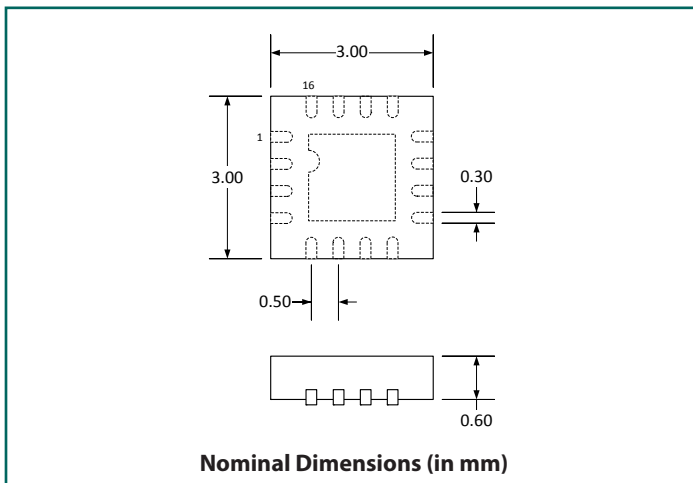

Features

- EMI/RFI filter with integrated ESD protection
- ESD protection to IEC 61000-4-2 (ESD) Level 4, ± 20 kV (air), ± 12 kV (contact)
- Filter performance: >30 dB attenuation at 1.8GHz
- TVS working voltage: 2.5V
- Resistor: 100 Ω $\pm 15\%$
- Capacitance: 10pF typ. ($V_R = 0V$ for non filter pins)
- EMI & ESD protection for six lines
- Dedicated ESD protection for four lines
- Solid-state technology
- AEC-Q100 Grade 1 Qualified

Mechanical Characteristics

- SLP3030P16 package
- Pb-Free, Halogen Free, RoHS/WEEE compliant
- Nominal Dimensions: 3.0 x 3.0 x 0.6 mm
- Lead Pitch: 0.5mm
- Lead Finish: Matte Tin
- Marking: Marking Code
- Packaging: Tape and Reel per EIA 481

Applications

- Touch Screen Display Interfaces
- Secure Digital (SD) Memory Card Interfaces
- Multimedia Card Interfaces (MCI)
- Color LCD Panel Protection
- Cell Phone Handsets and Accessories
- Automotive Applications

Schematic & Pin Configuration

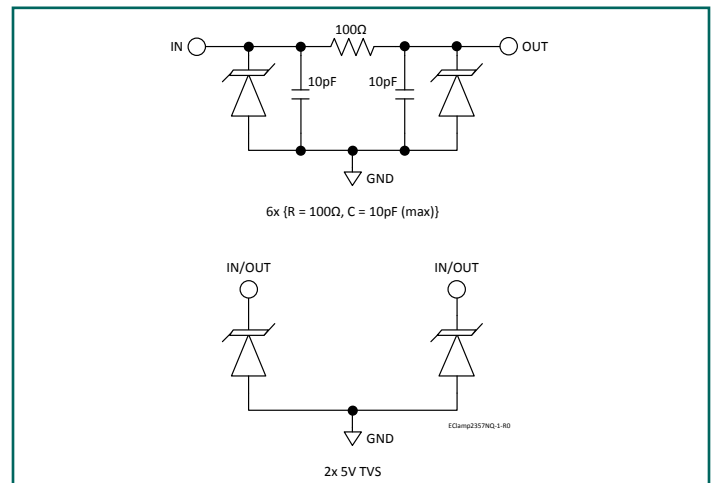

Absolute Maximum Ratings

Rating	Symbol	Value	Units
ESD per IEC 61000-4-2 (Contact) ⁽¹⁾ ESD per IEC 61000-4-2 (Air) ⁽¹⁾	V_{ESD}	± 12 ± 20	kV
Junction Temperature	T_J	125	°C
Operating Temperature	T_{OP}	-40 to +125	°C
Storage Temperature	T_{STG}	-55 to +150	°C

Electrical Characteristics (T=25°C unless otherwise specified)

Parameter	Symbol	Conditions	Min.	Typ.	Max.	Units	
Reverse Stand-Off Voltage	V_{RWM}	-40°C to 125°C, any I/O to GND			2.5	V	
Reverse Breakdown Voltage	V_{BR}	$I_t = 1\text{mA}$, any I/O to GND	-40°C to 125°C	6	8	10	V
Reverse Leakage Current	I_R	$V_{RWM} = 2.5\text{V}$, any I/O to GND	-40°C to 125°C		0.5	μA	
Total Series Resistance	R	Each line, T = -40 °C to 125 °C	85	100	115	Ω	
Total Capacitance	C_{IN}	Input to Gnd, each Line, f = 1 MHz	$V_R = 0\text{V}$		20	22	pF
			$V_R = 2.5\text{V}$		12	15	

Notes:

(1): ESD Gun return path to Ground Reference Plane (GRP)

Typical Characteristics

Typical Insertion Loss -S21 (Each Filter)

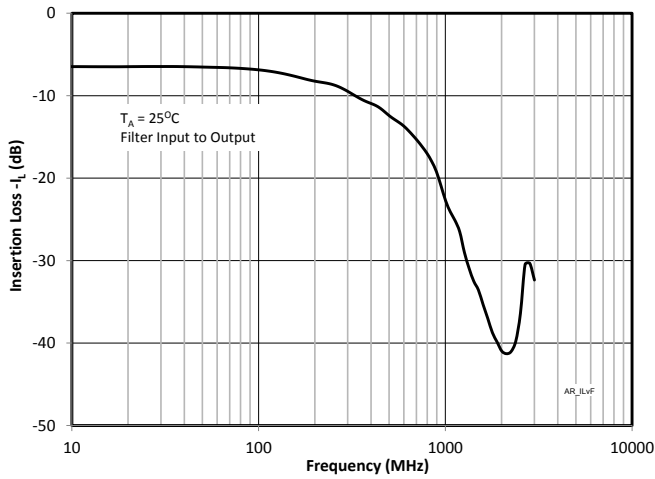

Analog Crosstalk (Each Line)

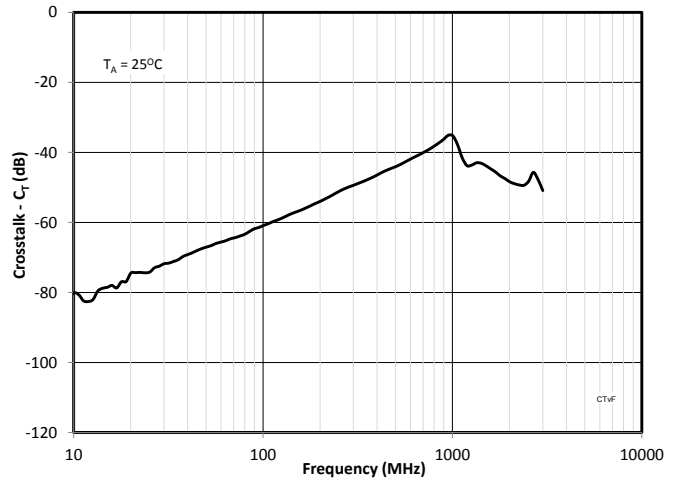

ESD Clamping (+8kV Contact per IEC 61000-4-2)

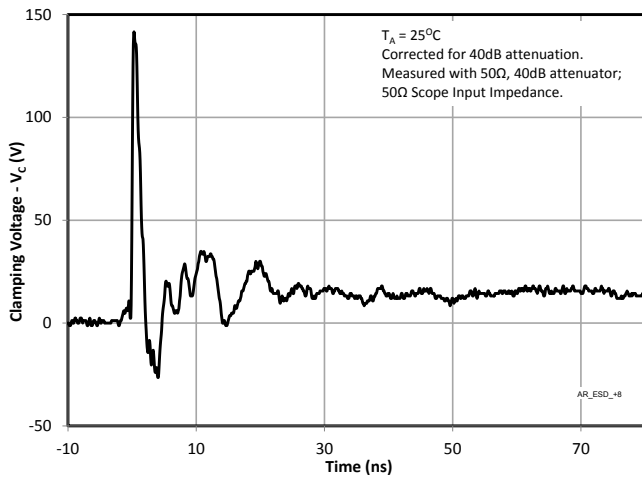

ESD Clamping (-8kV Contact per IEC 61000-4-2)

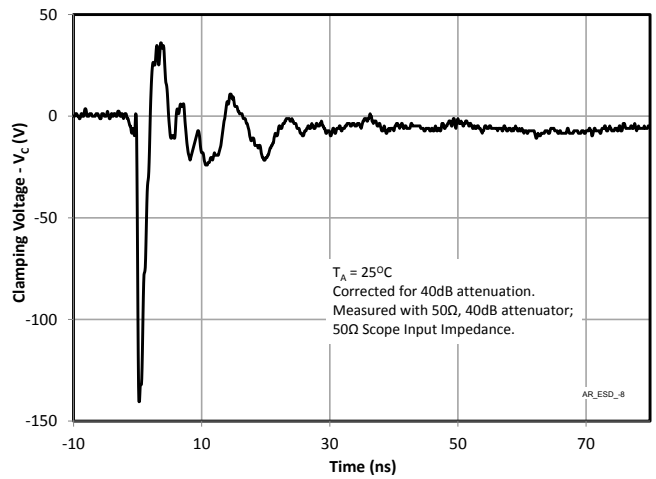

Capacitance vs. Temperature

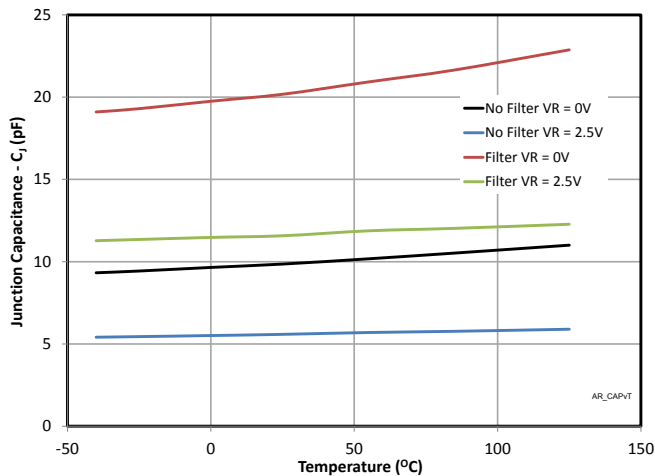

Series Resistance vs. Temperature

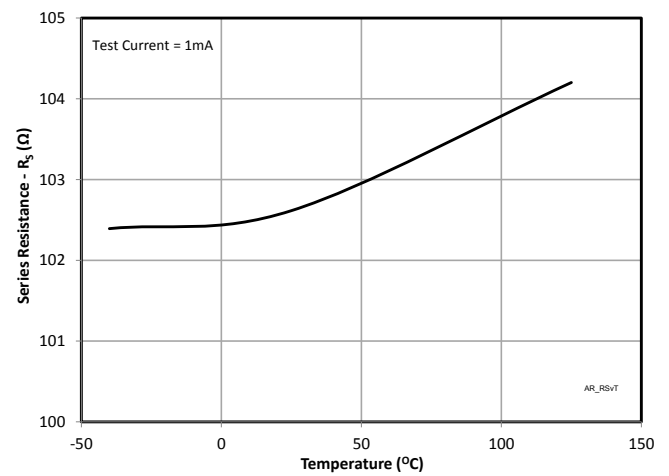

Typical Characteristics (Continued)

Breakdown Voltage vs. Temperature

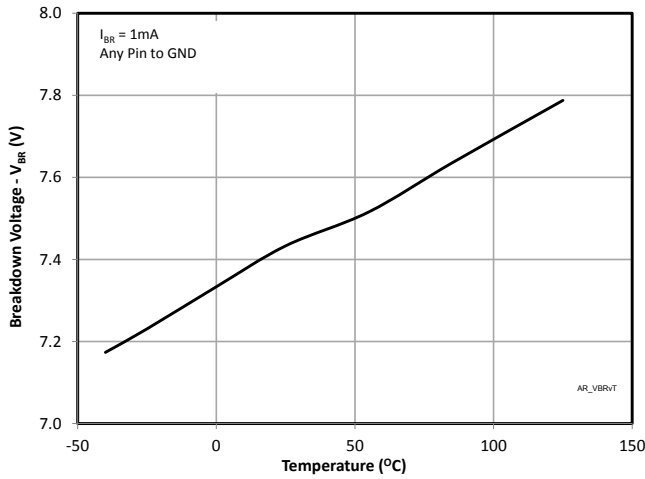

Capacitance vs. Reverse Voltage

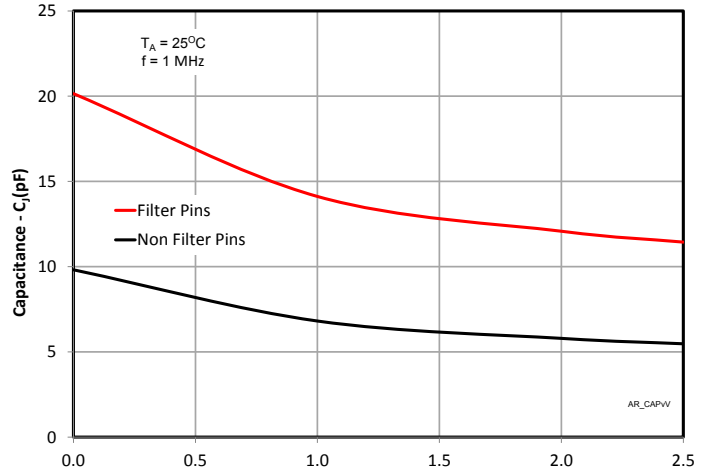

TLP Characteristics (Positive)

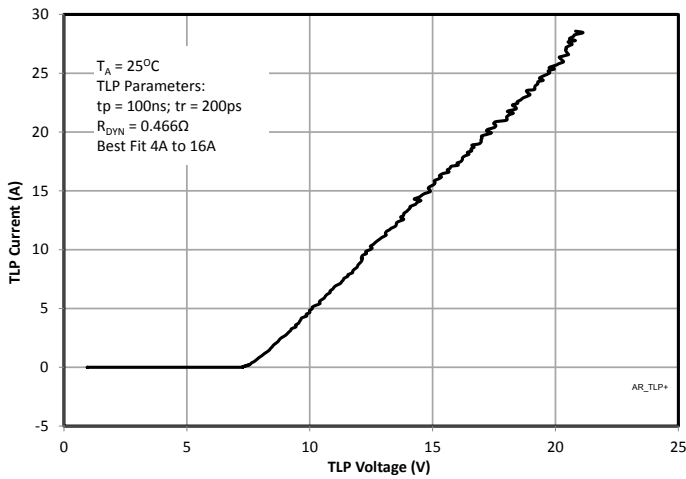

TLP Characteristics (Negative)

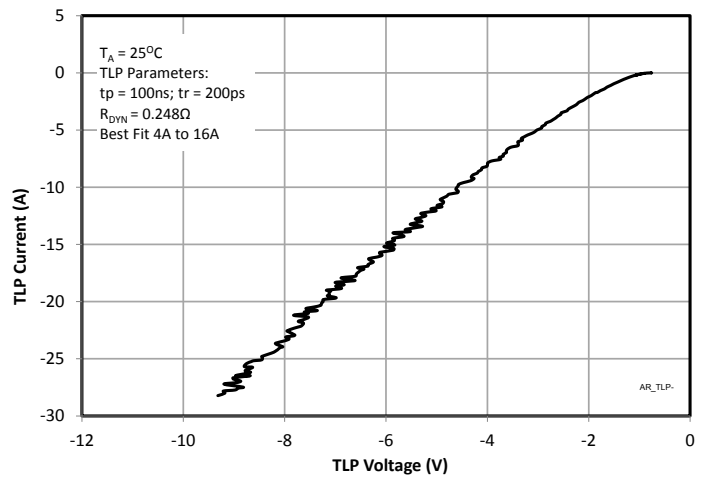

Leakage Current vs. Temperature

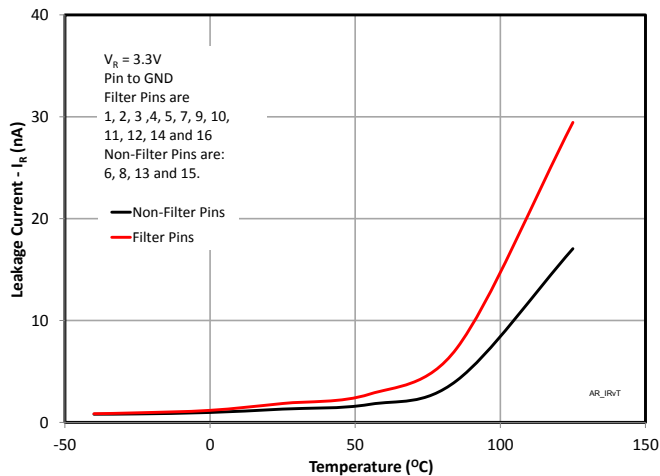

Application Information

Device Connection

The EClamp2357NQ is comprised of six circuits each consisting of a low pass filter for EMI/RFI suppression and dual TVS diodes for ESD protection. It also includes 4 lines of TVS diodes for ESD protection of power lines or high speed I/O lines. The device is housed in a 16-pin Quad Flat No-Lead (QFN) package. Electrical connection is made via 16 pins located at the bottom of the device. A center tab serves as the ground connection. Pin connections are noted in the table to the right. The device is designed for easy PCB routing as shown in the application examples. All path lengths should be kept as short as possible to minimize the effects of parasitic inductance in the board traces.

Matte Tin Lead Finish

Matte tin has become the industry standard lead-free replacement for SnPb lead finishes. A matte tin finish is composed of 100% tin solder with large grains. Since the solder volume on the leads is small compared to the solder paste volume that is placed on the land pattern of the PCB, the reflow profile will be determined by the requirements of the solder paste. Therefore, these devices are compatible with both lead-free and SnPb assembly techniques. In addition, unlike other lead-free compositions, matte tin does not have any added alloys that can cause degradation of the solder joint.

Pin Identification and Configuration (Top Side View)

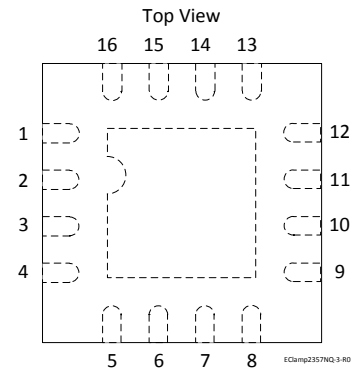

Pin	Identification
3, 4, 5, 7, 9, 10	Input EMI/ESD Protected Lines
1, 2, 11, 12, 14, 16	Output EMI/ESD Protected Lines
6, 8, 13, 15	Input/Output ESD Protected Lines
Center Tab	Ground

Pin Configuration and Schematic

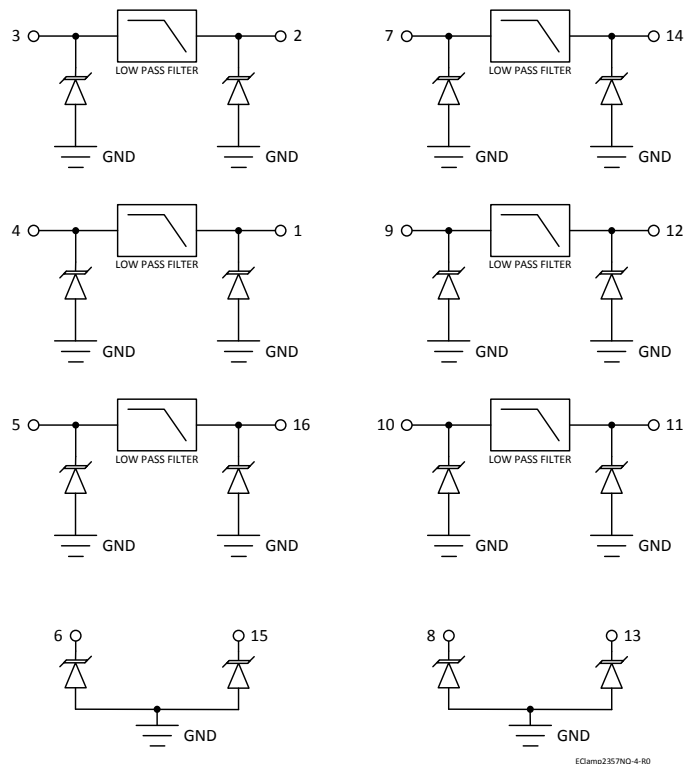

Application Information

EClamp2357NQ SD Memory

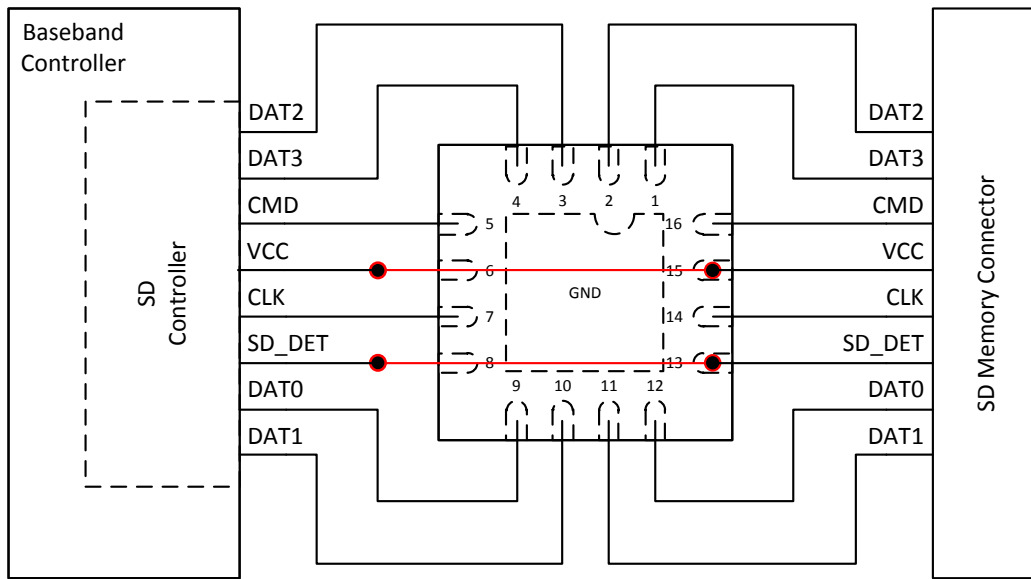

EClamp2357NQ-5-R0

Key ——— Top Side Trace ——— Bottom Side Trace ● Via

EClamp2357NQ LCD and Touch Pad

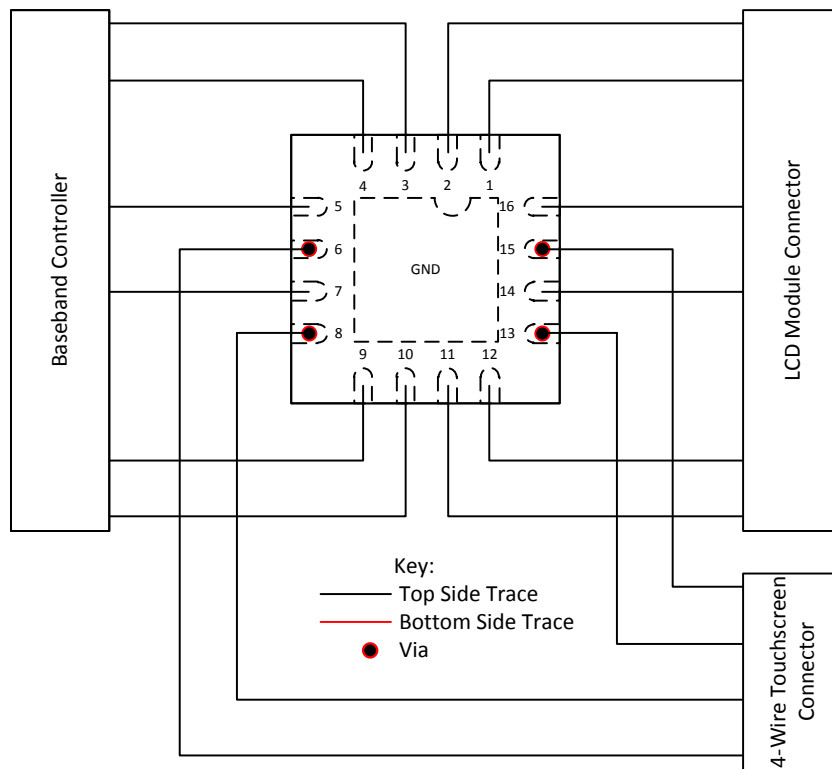

EClamp2357NQ-6-R0

Outline Drawing - SLP3030P16

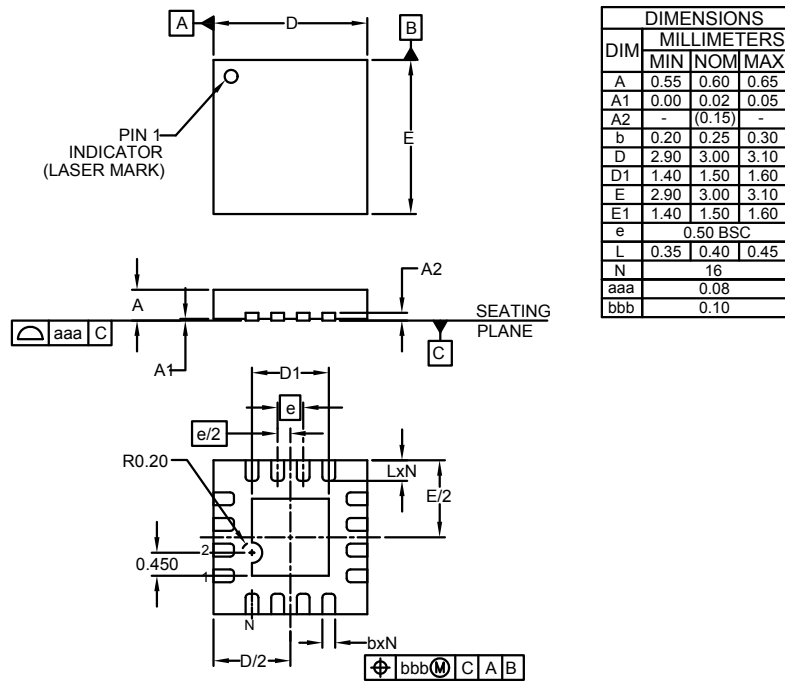

- NOTES:
1. CONTROLLING DIMENSIONS ARE IN MILLIMETERS (ANGLES IN DEGREES).
 2. COPLANARITY APPLIES TO THE EXPOSED PAD AS WELL AS THE TERMINALS.

Land Pattern - SLP3030P16

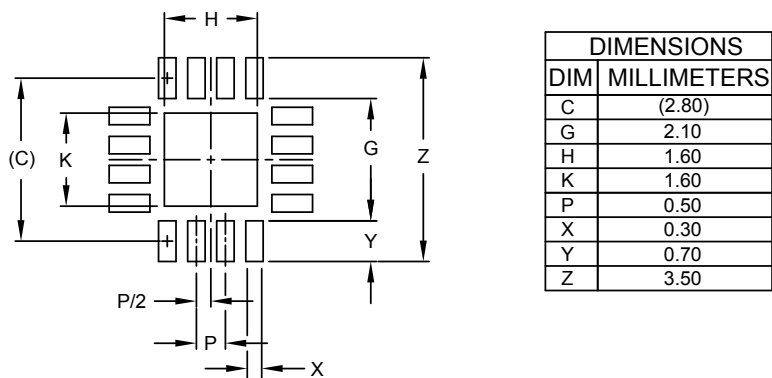

- NOTES:
1. THIS LAND PATTERN IS FOR REFERENCE PURPOSES ONLY. CONSULT YOUR MANUFACTURING GROUP TO ENSURE YOUR COMPANY'S MANUFACTURING GUIDELINES ARE MET.
 2. DO NOT PLACE VIAS BETWEEN THE CORNER LEADS INSIDE THE 3X3MM PACKAGE FOOTPRINT.
 3. THERMAL VIAS IN THE LAND PATTERN OF THE EXPOSED PAD SHALL BE CONNECTED TO A SYSTEM GROUND PLANE. FAILURE TO DO SO MAY COMPROMISE THE THERMAL AND/OR FUNCTIONAL PERFORMANCE OF THE DEVICE.

Marking Code

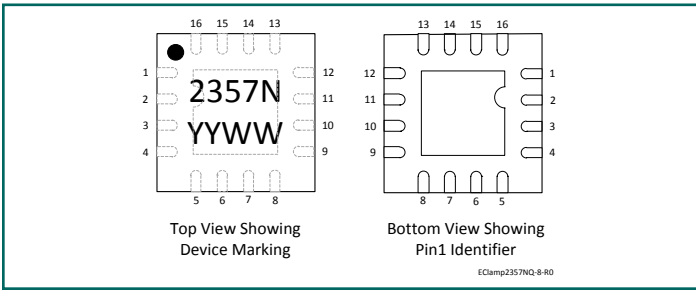

Notes:

1. YYWW = Alphanumeric character Date Code
2. Pin 1 indicated by "Mouse Bite" on the ground pad

Tape and Reel Specification - Plastic Tape

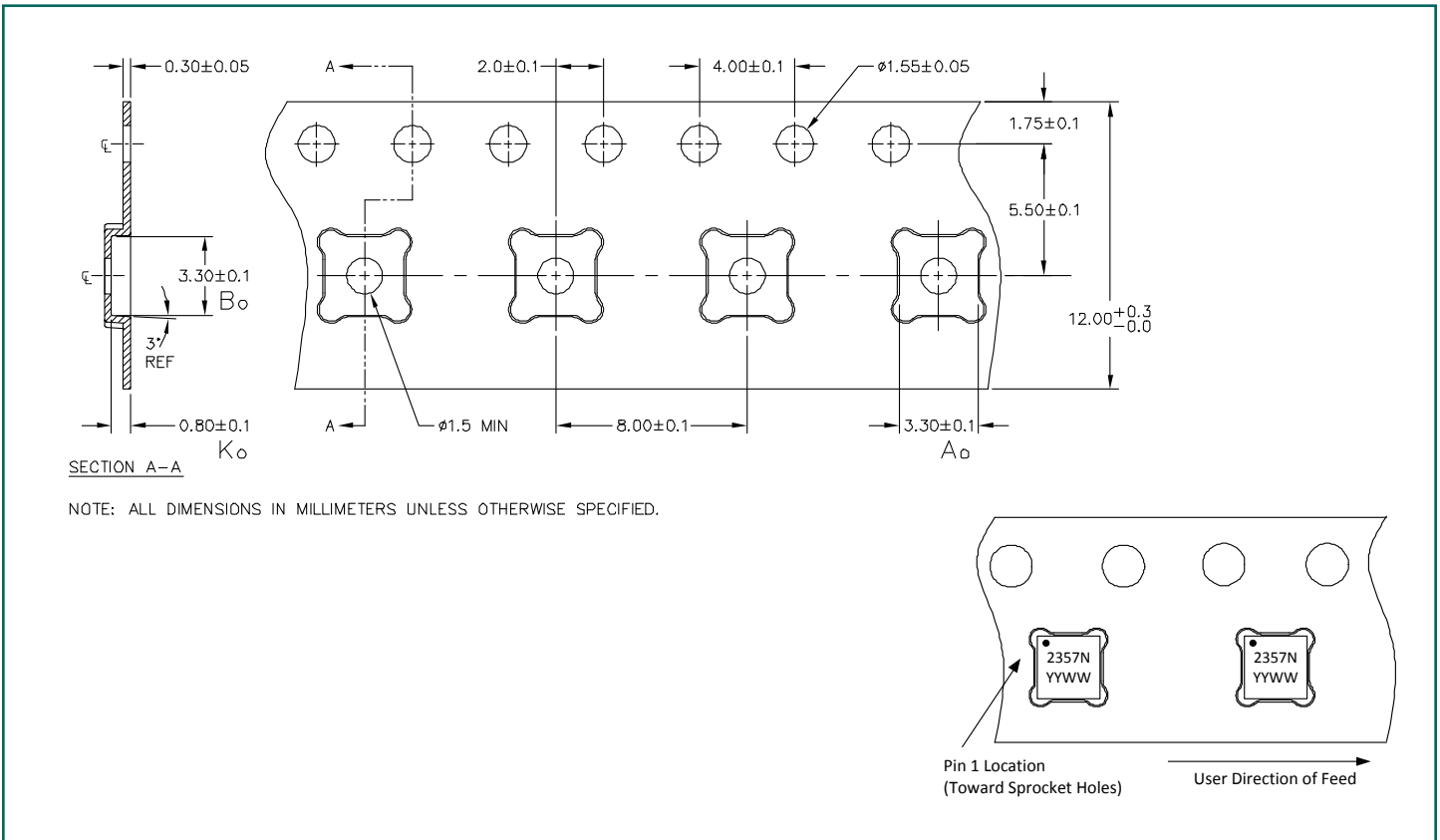

Ordering Information

Part Number	Qty per Reel	Reel Size
EClamp2357NQTLT	3000	13 Inch
EMIClamp and EClamp are trademarks of Semtech Corporation.		



IMPORTANT NOTICE

Information relating to this product and the application or design described herein is believed to be reliable, however such information is provided as a guide only and Semtech assumes no liability for any errors in this document, or for the application or design described herein. Semtech reserves the right to make changes to the product or this document at any time without notice. Buyers should obtain the latest relevant information before placing orders and should verify that such information is current and complete. Semtech warrants performance of its products to the specifications applicable at the time of sale, and all sales are made in accordance with Semtech's standard terms and conditions of sale.

SEMTECH PRODUCTS ARE NOT DESIGNED, INTENDED, AUTHORIZED OR WARRANTED TO BE SUITABLE FOR USE IN LIFE-SUPPORT APPLICATIONS, DEVICES OR SYSTEMS, OR IN NUCLEAR APPLICATIONS IN WHICH THE FAILURE COULD BE REASONABLY EXPECTED TO RESULT IN PERSONAL INJURY, LOSS OF LIFE OR SEVERE PROPERTY OR ENVIRONMENTAL DAMAGE. INCLUSION OF SEMTECH PRODUCTS IN SUCH APPLICATIONS IS UNDERSTOOD TO BE UNDERTAKEN SOLELY AT THE CUSTOMER'S OWN RISK. Should a customer purchase or use Semtech products for any such unauthorized application, the customer shall indemnify and hold Semtech and its officers, employees, subsidiaries, affiliates, and distributors harmless against all claims, costs damages and attorney fees which could arise.

The Semtech name and logo are registered trademarks of the Semtech Corporation. All other trademarks and trade names mentioned may be marks and names of Semtech or their respective companies. Semtech reserves the right to make changes to, or discontinue any products described in this document without further notice. Semtech makes no warranty, representation or guarantee, express or implied, regarding the suitability of its products for any particular purpose. All rights reserved.

© Semtech 2015

Contact Information

Semtech Corporation
200 Flynn Road, Camarillo, CA 93012
Phone: (805) 498-2111, Fax: (805) 498-3804
www.semtech.com

X-ON Electronics

Largest Supplier of Electrical and Electronic Components

Click to view similar products for [ESD Suppressors / TVS Diodes](#) category:

Click to view products by [Semtech](#) manufacturer:

Other Similar products are found below :

[NTE4902](#) [P4SMAJ15A](#) [P4SMAJ26A](#) [SMAJ400CA-TP](#) [TGL34-47CA](#) [ESDAULC45-1BF4](#) [SM1605E3/TR13](#) [SMF20A-TP](#) [P4SMAJ12A](#)
[CPDUR24V-HF](#) [CPDQC5V0USP-HF](#) [CPDQC5V0-HF](#) [MPLAD30KP45CAE3](#) [MMBZ27VCLQ-7-F](#) [MMAD1108/TR13](#) [MPLAD30KP24A](#)
[ACPDQC5V0R-HF](#) [DFLT170A-7](#) [NTE4900](#) [NTE4926](#) [NTE4938](#) [SMF22A-TP](#) [SMF12A-TP](#) [SLVU2.8-TP](#) [SMLJ6.5CA-TP](#) [SMAJ6.5CA-](#)
[TP](#) [MMAD1108E3/TR13](#) [D5V0M1U2LP3-7](#) [SMAJ400A-TP](#) [AOZ8811DT-03](#) [AOZ8831DI-05](#) [AOZ8831DT-03](#) [SMAJ188CA](#) [3SMC33CA](#)
[BK](#) [CPDQC3V3C-HF](#) [CPDQC12VE-HF](#) [MPLAD30KP170CA](#) [82357120100](#) [5.0SMLJ15CA-TP](#) [5KP18A-TP](#) [P6KE8.2A-TP](#)
[MPLAD30KP43CAE3](#) [SMAJ43A-TP](#) [D5V0F6U8LP33-7](#) [TVS5501V10MUT5G](#) [5.0SMLJ24CA-TP](#) [SMAJ110CA-TP](#) [MPLAD15KP75CAE3](#)
[MMAD1103e3/TR13](#) [DFLT40AQ-7](#)