

PROTECTION PRODUCTS

Description

EClamp®8052PQ integrates common mode filtering with low capacitance ESD protection and is designed specifically for MIPI, MHL, and USB interfaces. Each device provides filtering and ESD protection for one high-speed differential pair.

EClamp8052PQ is an easily implemented solution for replacing discrete common mode chokes and ESD protection devices in a single package. These devices utilize silicon avalanche technology for superior ESD and TLP clamping performance. They feature high maximum ESD withstand voltage of +/- 25kV contact, +/-30kV air discharge per IEC 61000-4-2. The integrated common-mode choke has a typical differential mode cutoff frequency >3GHz and typical common mode suppression of 10dB at 500MHz and 15dB from 1GHz to 2.8GHz. Each channel series resistance is 1.8 Ohms maximum.

EClamp8052PQ is in a 7-pin SGP1917N5 package, measuring 1.9 x 1.7mm with a nominal height of 0.55mm. The leads have a nominal pin-to-pin pitch of 0.50mm. Flow-through package design simplifies PCB layout and maintains signal integrity on high-speed lines.

Circuit Diagram

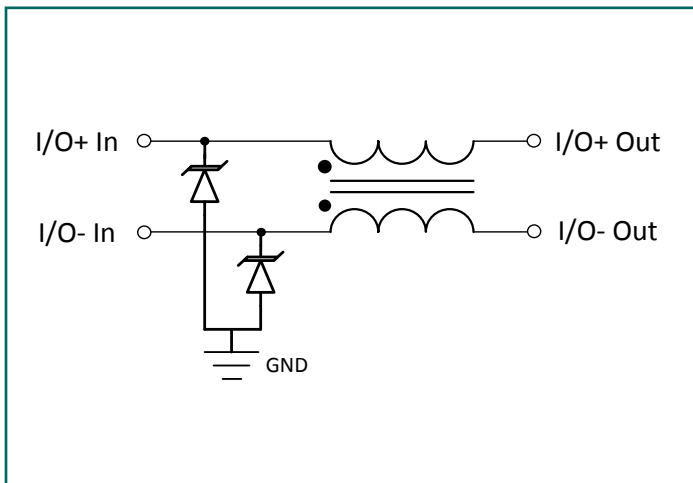

Features

- Transient Protection to
 - ♦ IEC 61000-4-2 (ESD) 30kV (Air), 25kV (Contact)
 - ♦ IEC 61000-4-4 (EFT) 4kV (5/50ns)
 - ♦ IEC 61000-4-5 (Lightning) 6A (8/20µs)
 - ♦ ISO-10605 (ESD) 30kV (Air), 25kV (Contact)
- Qualified to AEC-Q100, Grade 1
- Package design optimized for high speed lines
- ESD protection and common mode filtering for two high-speed lines
- High differential bandwidth cutoff frequency
- Low ESD Clamping Voltage
- Dynamic Resistance: 0.50 Ohms (Typ)
- Solid-State Silicon-Avalanche Technology

Mechanical Characteristics

- SGP1917N5 package
- Pb-Free, Halogen Free, RoHS/WEEE Compliant
- Nominal Dimensions: 1.9 x 1.70 x 0.55 mm
- Molding Compound Flammability Rating: UL 94V-0
- Marking : Marking Code + Date Code
- Packaging : Tape and Reel

Applications

- Automotive Applications
- Industrial Equipment
- USB 2.0 / USB 3.0
- HDMI / MHL
- MIPI Camera Serial Interface (CSI)
- MIPI Display Serial Interface (DSI)

Pin Configuration

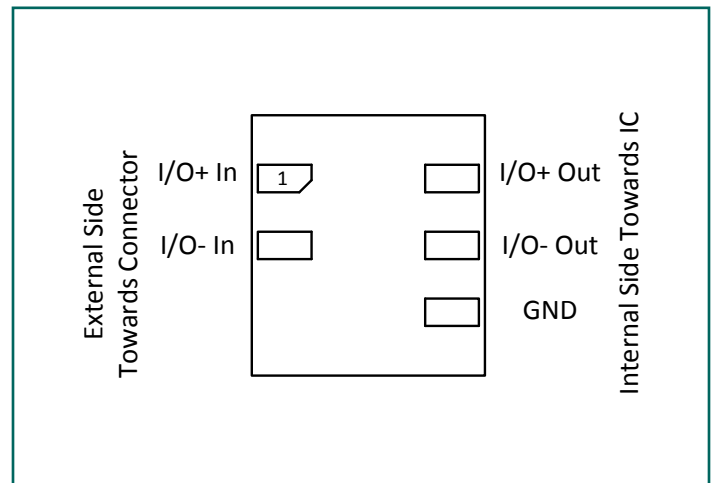

Absolute Maximum Ratings

Rating	Symbol	Value	Units
Peak Pulse Current (tp = 8/20μs)	I _{PP}	6	A
ESD per IEC 61000-4-2 (Contact) ⁽¹⁾ ESD per IEC 61000-4-2 (Air) ⁽¹⁾	V _{ESD}	±25 ±30	kV
ESD per ISO-10605 (Contact) ⁽²⁾ ESD per ISO-10605 (Air) ⁽²⁾	V _{ESD}	±25 ±30	kV
Operating Temperature	T _J	-40 to +125	°C
Storage Temperature	T _{STG}	-55 to +150	°C

Electrical Characteristics (T=25°C unless otherwise specified)

Parameter	Symbol	Conditions	Min.	Typ.	Max.	Units	
Reverse Stand-Off Voltage	V _{RWM}	-40°C to 125°C Pin 1 or Pin 2 to Pin 3			5	V	
Reverse Breakdown Voltage	V _{BR}	I _t = 1mA, Pin 1 or 2 to Pin 3	-40°C to 125°C	6.5	9	11	V
Reverse Leakage Current	I _R	V _{RWM} = 5V T = 25°C		0.005	0.100	μA	
Clamping Voltage	V _C	I _{pp} = 1A, tp = 8/20μs, Pin 1 or 2 to Pin 3			12	V	
Clamping Voltage	V _C	I _{pp} = 6A, tp = 8/20μs, Pin 1 or 2 to Pin 3			17	V	
ESD Clamping Voltage ⁽³⁾	V _C	I _{pp} = 4A, tp = 0.2/100ns (TLP) Pin 1 or 2 to Pin 3		11		V	
ESD Clamping Voltage ⁽³⁾	V _C	I _{pp} = 16A, tp = 0.2/100ns (TLP) Pin 1 or 2 to Pin 3		17		V	
Dynamic Resistance ^{(3),(4)}	R _{DYN}	tp = 0.2/100ns (TLP) Pin 1 or 2 to Pin 3		0.50		Ohms	
Total Channel Capacitance	C _{IN}	V _R = 0V, f = 1MHz Pin 1 or 2 to Pin 3 T = 25°C		0.95	1.2	pF	
Differential (SDD21) Cut-Off Frequency	f _{3dB}	50 Ohm Source and Load Termination		3		GHz	
Common Mode (SCC21) Attenuation	f _{ATT}	f = 75MHz		3		dB	
		f = 500MHz		10		dB	
		f = 1GHZ - 2.5GHZ		20		dB	
Channel Resistance	R _{CH}	Input to Output		1.3	1.8	Ohms	

Notes:

(1): ESD Gun return path to Ground Reference Plane (GRP)

(2): ESD Gun return path to Horizontal Coupling Plane (HCP); Test conditions: a)150pF/330pF, 330Ω b) 150pF/330pF, 2kΩ

(3): Transmission Line Pulse Test (TLP) Settings: tp = 100ns, tr = 0.2ns, I_{TLP} and V_{TLP} averaging window: t₁ = 70ns to t₂ = 90ns.

(4): Dynamic resistance calculated from I_{TLP} = 4A to I_{TLP} = 16A

Typical Characteristics

Differential Mode Attenuation vs. Frequency

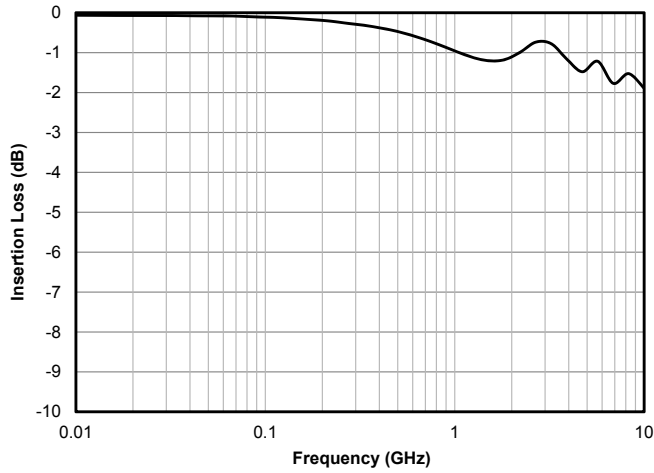

Common Mode Attenuation vs. Frequency

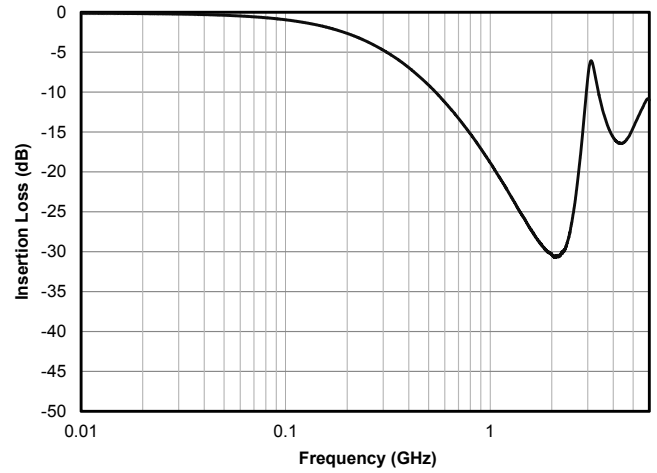

Junction Capacitance vs. Reverse Voltage

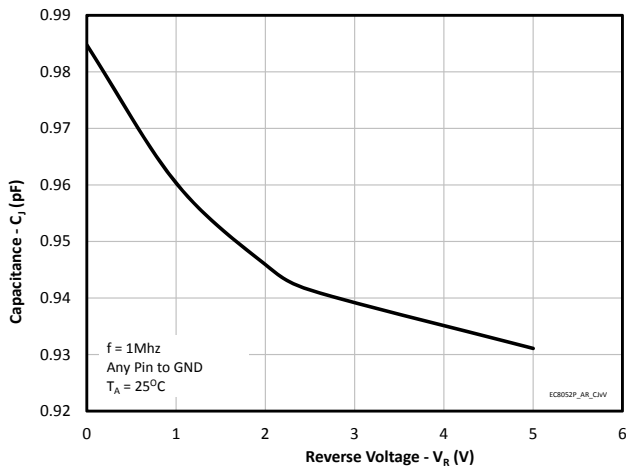

Junction Capacitance vs. Temperature

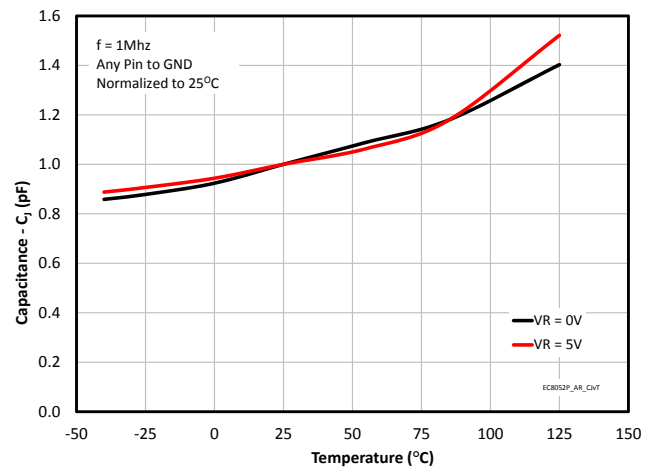

Channel DC Resistance vs. Temperature

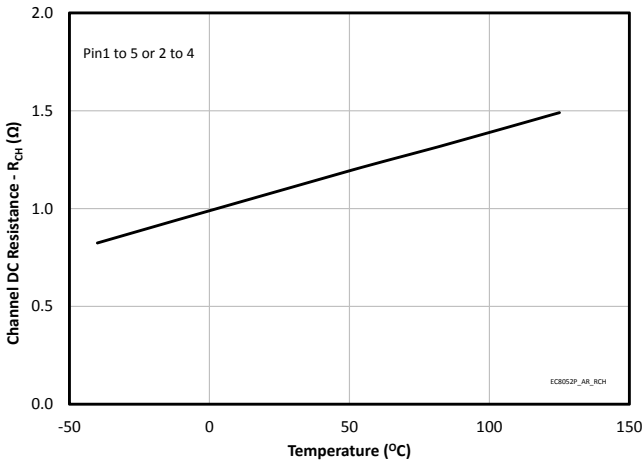

Breakdown Voltage (VBR) vs. Temperature

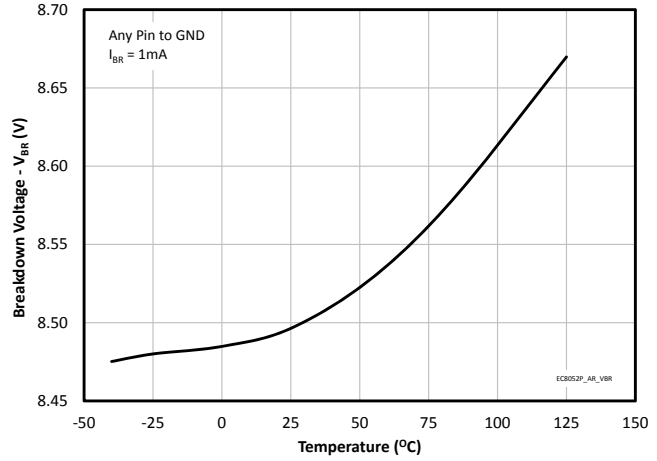

Typical Characteristics

ESD Clamping (+8kV Contact per IEC 61000-4-2)

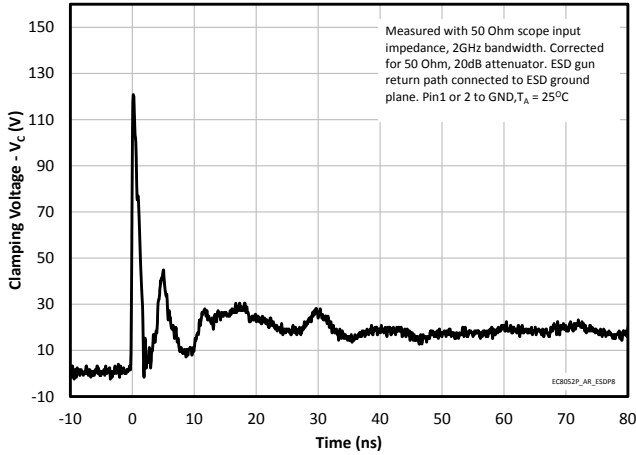

ESD Clamping (-8kV Contact per IEC 61000-4-2)

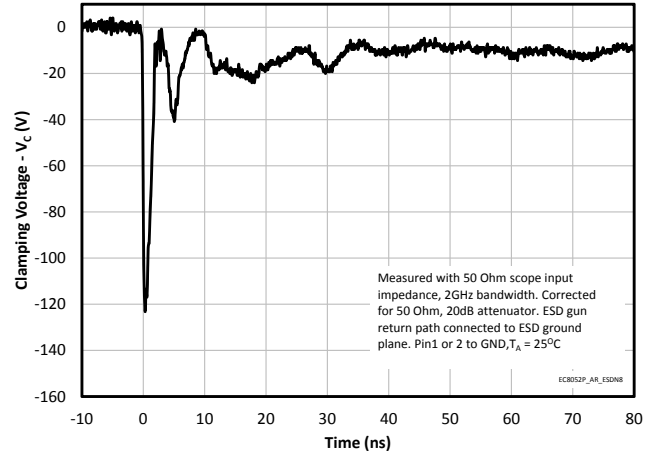

TLP Characteristic (Positive)

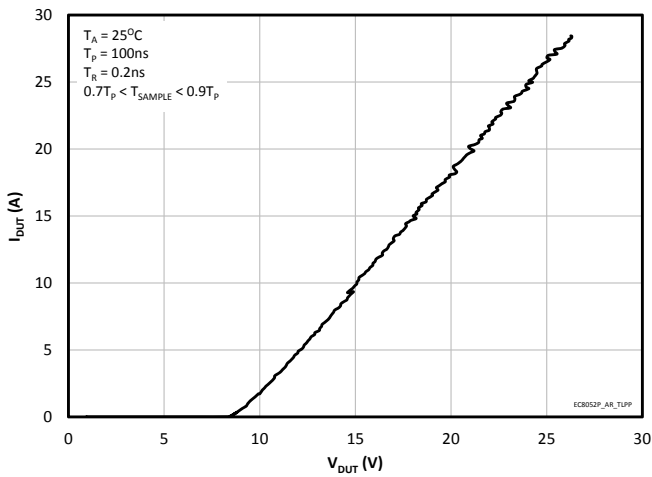

TLP Characteristic (Negative)

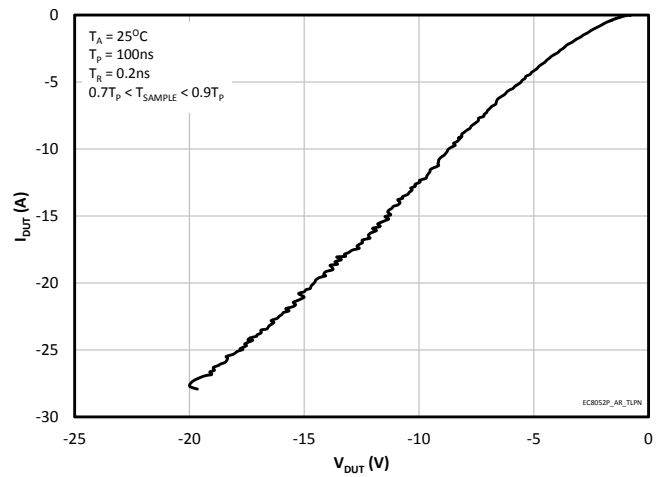

Clamping Voltage vs. Peak Pulse Current (tp=8/20us)

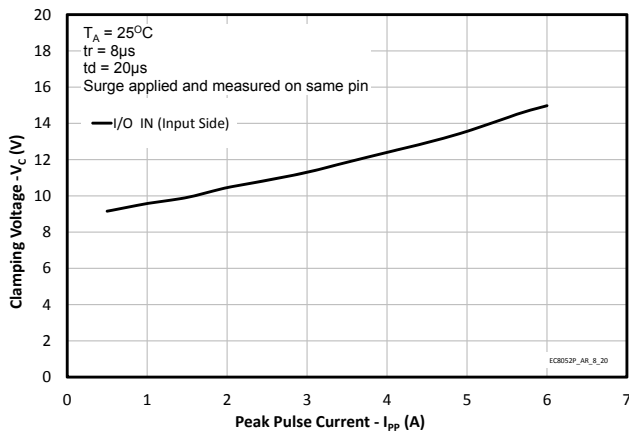

Reverse Leakage vs. Temperature

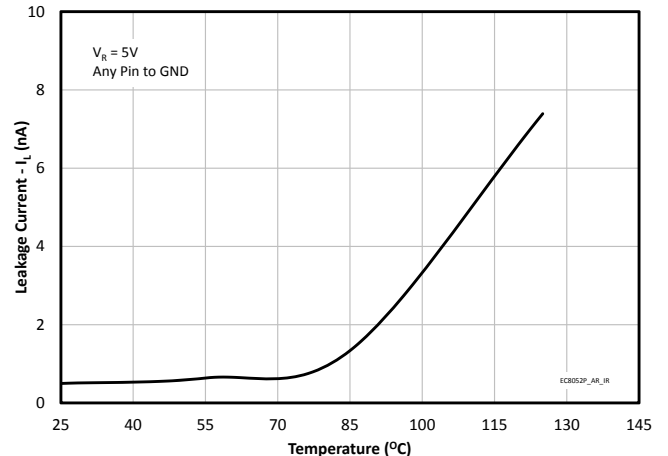

Application Information

USB Interface Protection

EClamp8052PQ may be used to protect D+ and D- lines against ESD and EMI in USB 2.0, USB 3.0, and USB 3.1 applications. USB D+ and D- lines enter at pins 1 and 2 (connector side) and exit at pins 4 and 5. The TVS diodes are internally connected at pins 1 and 2 and therefore must be located towards the connector on the PCB. Pin 3 is connected to the ground plane. Figures 1 is an example of protecting a USB 3.0 Type-A interface (host side shown).

For USB 3.0 applications, RClamp3324T is recommended for protecting the 5Gb/s SuperSpeed line pairs. Lines are routed through the device at pins 1-4. Traces should be kept the same length to avoid impedance mismatch. Ground is connected at pins 5 and 6. The differential impedance of each pair can be controlled for USB 3.0 (85 Ohms +/-15%) while maintaining a minimum trace-to-trace and trace-to-pad spacing. Individual PCB design constraints may necessitate different spacing or trace

width. Both ground pads should be connected for optimal performance. Ground connection is made using filled via-in-pad. Additional information may be found on the device data sheet.

Single line devices such as uClamp0571P are recommended for surge and ESD protection of the VBus line. This device features high surge and ESD capability and may be used on 5V power rails.

Device Placement

Placement of the protection component is a critical element for effective ESD suppression. TVS diodes should be placed as close to the connector as possible. This helps reduce transient coupling to nearby traces. Ground connections should be made directly to the ground plane using micro-vias. This reduces parasitic inductance in the ground path and minimizes the clamping voltage seen by the protected device.

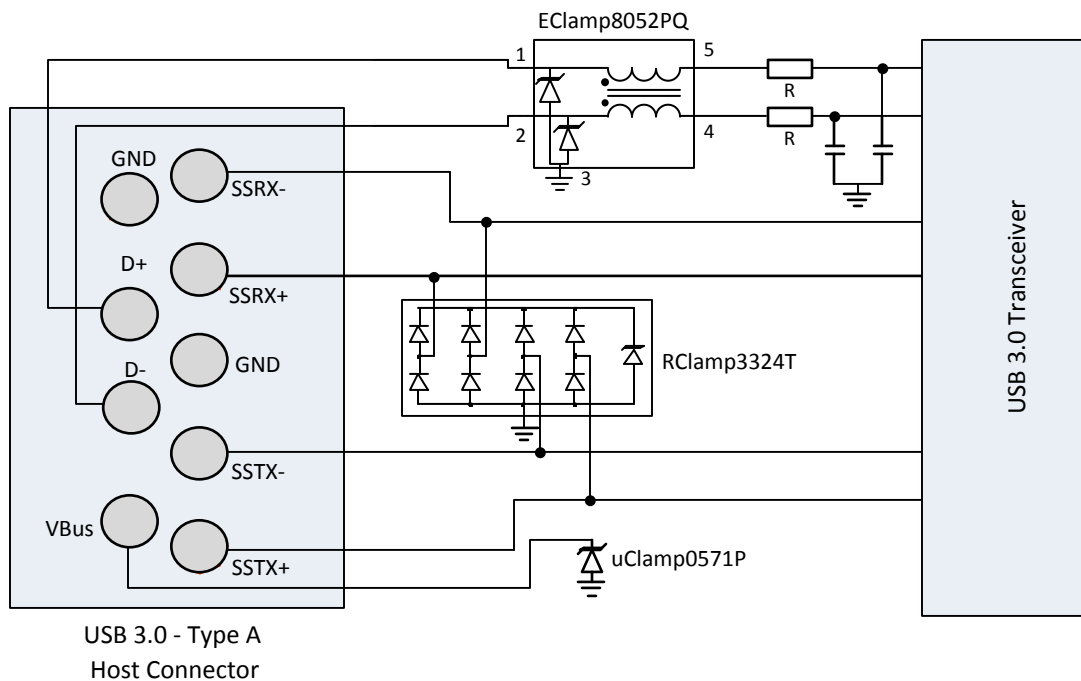

Figure 1 - USB 3.0 Type-A Protection Example

Application Information

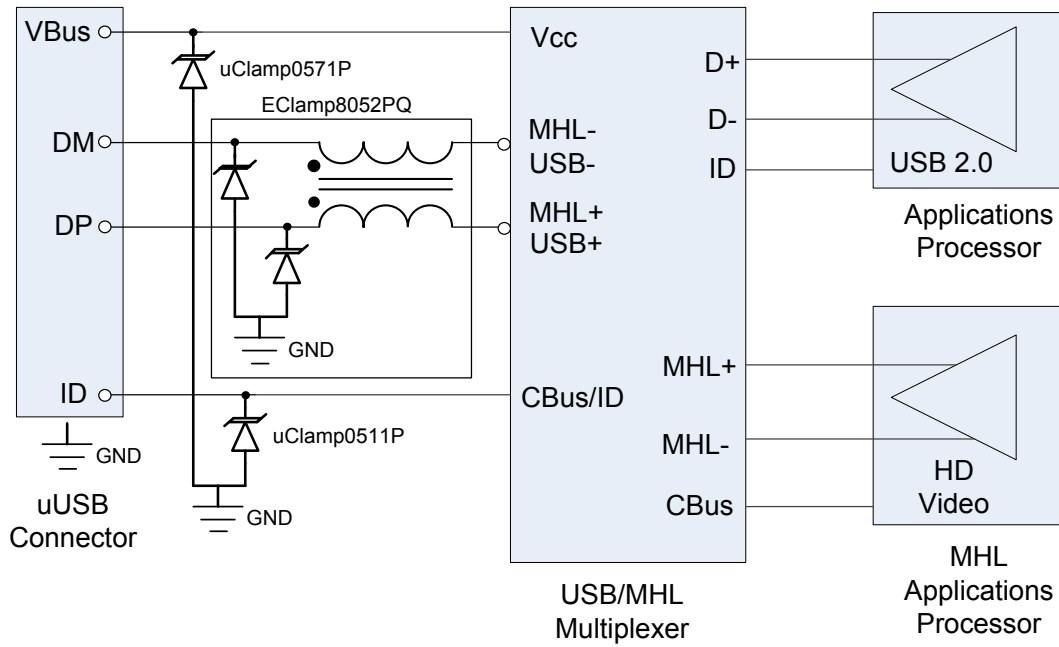

Figure 2 - USB2.0 / MHL Interface Protection

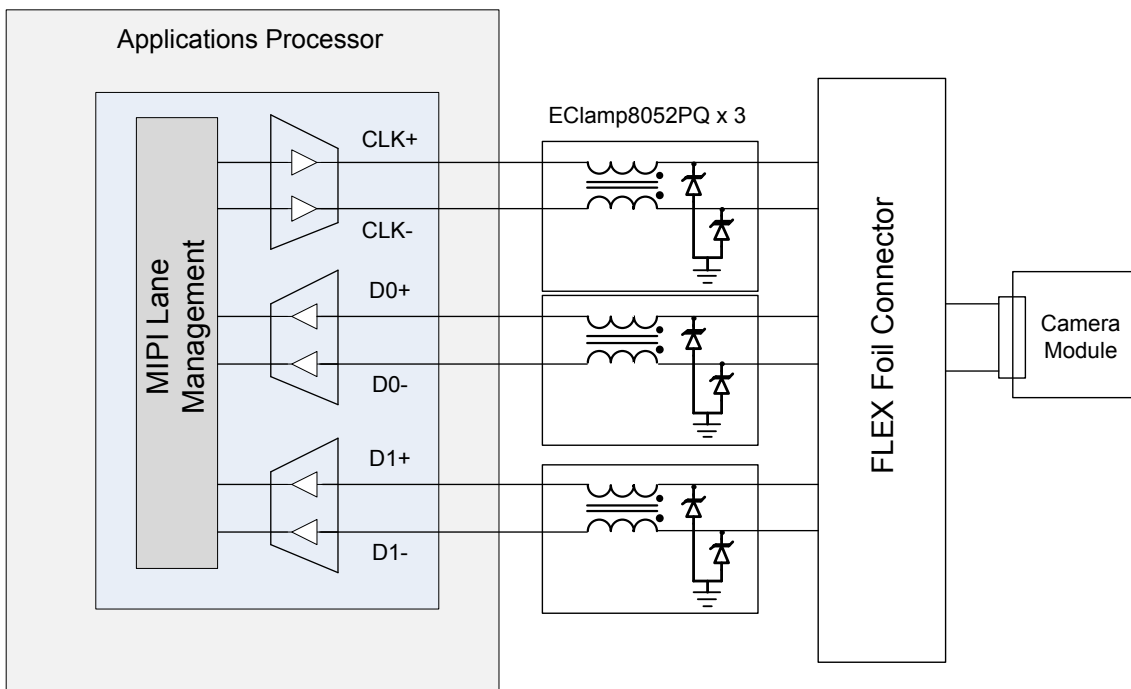
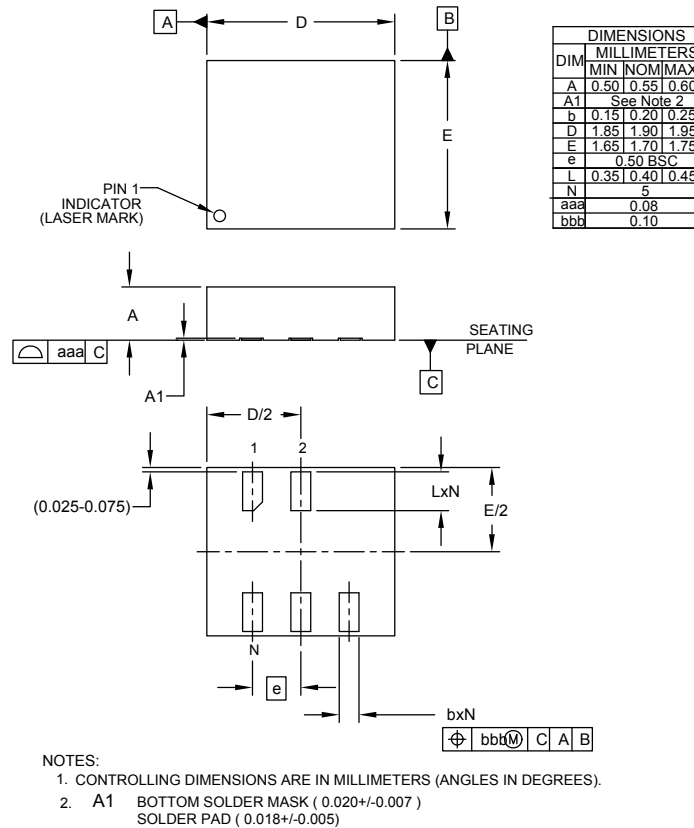
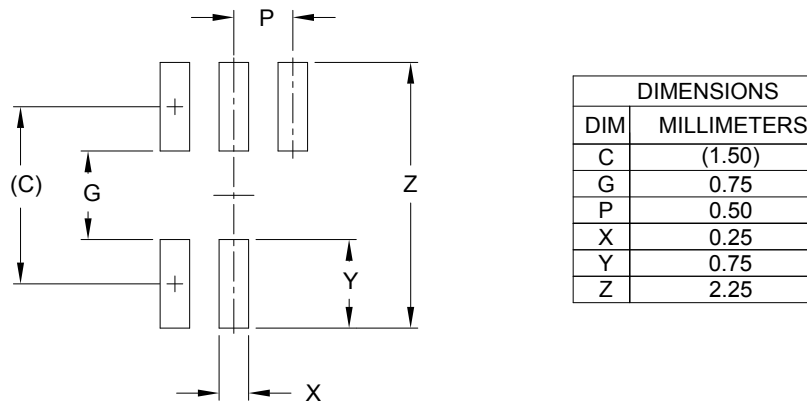

Figure 3 - MIPI Camera Serial Interface Protection

Outline Drawing - SGP1917N5



Land Pattern - SGP1917N5



Marking Code

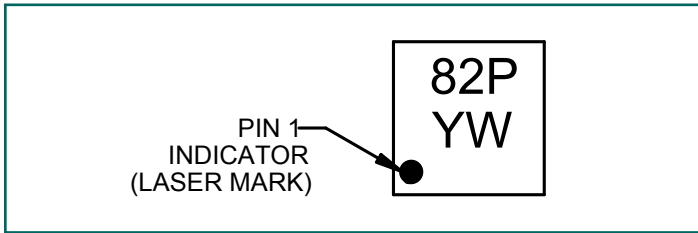

YW = Alphanumeric character Date Code

Tape and Reel Specification - Plastic Tape, 4mm Pitch

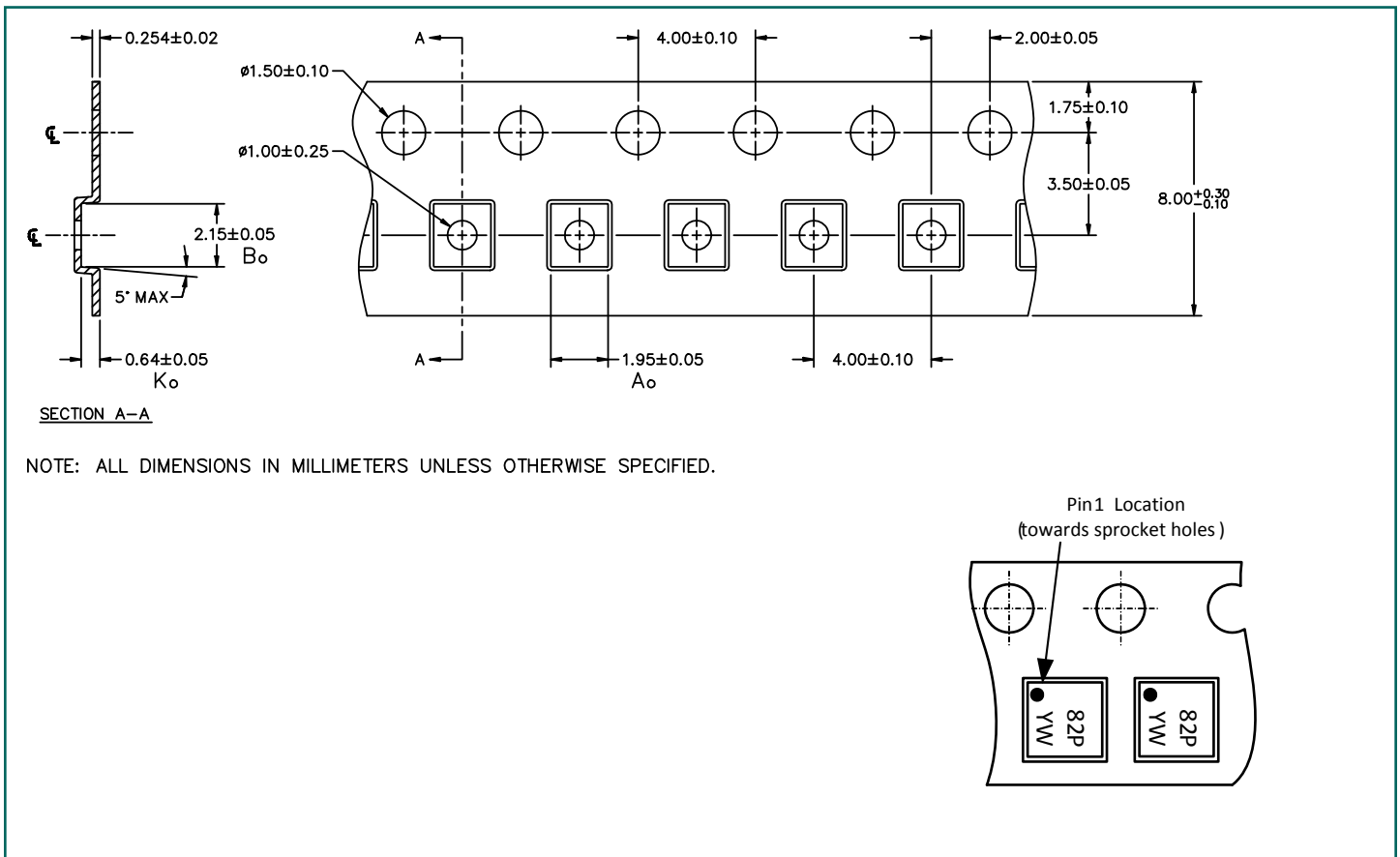

Ordering Information

Part Number	Qty per Reel	Reel Size	Carrier Tape	Pitch
EClamp8052PQTCT	3000	7 Inch	Plastic	4mm

EMIClamp and EClamp are trademarks of Semtech Corporation.

X-ON Electronics

Largest Supplier of Electrical and Electronic Components

Click to view similar products for [ESD Suppressors / TVS Diodes](#) category:

Click to view products by [Semtech](#) manufacturer:

Other Similar products are found below :

[60KS200C](#) [D12V0H1U2WS-7](#) [D18V0L1B2LP-7B](#) [82356050220](#) [D5V0M5U6V-7](#) [NTE4902](#) [P4KE27CA](#) [P6KE11CA](#) [P6KE39CA-TP](#)
[P6KE8.2A](#) [SA110CA](#) [SA60CA](#) [SA64CA](#) [SMBJ12CATR](#) [SMBJ8.0A](#) [SMLJ30CA-TP](#) [ESD101-B1-02ELS E6327](#) [ESD112-B1-02EL E6327](#)
[ESD119B1W01005E6327XTSA1](#) [ESD5V0L1B02VH6327XTSA1](#) [ESD7451N2T5G](#) [19180-510](#) [CPDT-5V0USP-HF](#) [3.0SMCJ33CA-F](#)
[3.0SMCJ36A-F](#) [HSPC16701B02TP](#) [D3V3Q1B2DLP3-7](#) [D55V0M1B2WS-7](#) [DESD5V0U1BL-7B](#) [DRTR5V0U4SL-7](#) [SCM1293A-04SO](#)
[ESD200-B1-CSP0201 E6327](#) [ESD203-B1-02EL E6327](#) [SM12-7](#) [SMF8.0A-TP](#) [SMLJ45CA-TP](#) [CEN955 W/DATA](#) [82350120560](#)
[82356240030](#) [VESD12A1A-HD1-GS08](#) [CPDUR5V0R-HF](#) [CPDUR24V-HF](#) [CPDQC5V0U-HF](#) [CPDQC5V0USP-HF](#) [CPDQC5V0-HF](#)
[D1213A-01LP4-7B](#) [D1213A-02WL-7](#) [ESDLIN1524BJ-HQ](#) [5KP100A](#) [5KP15A](#)