

### PROTECTION PRODUCTS

#### Description

The LCDA15C-6 has been specifically designed to protect sensitive components which are connected to data and transmission lines from over voltages caused by electrostatic discharge (**ESD**), electrical fast transients (**EFT**), and **lightning**.

The low capacitance array configuration of the LCDA15C-6 allows the user to protect six high-speed data or I/O lines. They may be used on systems operating from 5 to 15 Volts. The high surge capability (500W,  $t_p=8/20\mu s$ ) makes the LCDA15C-6 suitable for telecommunications systems operating in harsh transient environments. The low inductance construction minimizes voltage overshoot during high current surges.

The features of the LCDA15C-6 are ideal for protecting multi-protocol transceivers in WAN applications such as Frame Relay systems, routers, and switches.

#### Features

- ◆ Transient protection for high-speed data lines to **IEC 61000-4-2 (ESD)  $\pm 15kV$  (air),  $\pm 8kV$  (contact)**  
**IEC 61000-4-4 (EFT) 40A (5/50ns)**  
**IEC 61000-4-5 (Lightning) 0.5kV, 12A (8/20 $\mu s$ )**
- ◆ Protects six I/O lines
- ◆ Low capacitance for high-speed interfaces
- ◆ High surge capability
- ◆ Low clamping voltage
- ◆ Solid-state silicon avalanche technology

#### Mechanical Characteristics

- ◆ JEDEC SO-8 package
- ◆ Molding compound flammability rating: UL 94V-0
- ◆ Marking : Part number, date code, logo
- ◆ Packaging : Tape and Reel per EIA 481

#### Applications

- ◆ Multi-Mode Transceiver Protection
- ◆ WAN Equipment:
  - CSU/DSU
  - Multiplexers
  - Routers
  - ISP Equipment
  - Customer Premise Equipment
- ◆ Protection for any of the following interfaces:
  - RS-232 (V.28)
  - RS-422 (V.11, X.21)
  - RS-449 (V.11/V.10)
  - RS-485

#### Circuit Diagram

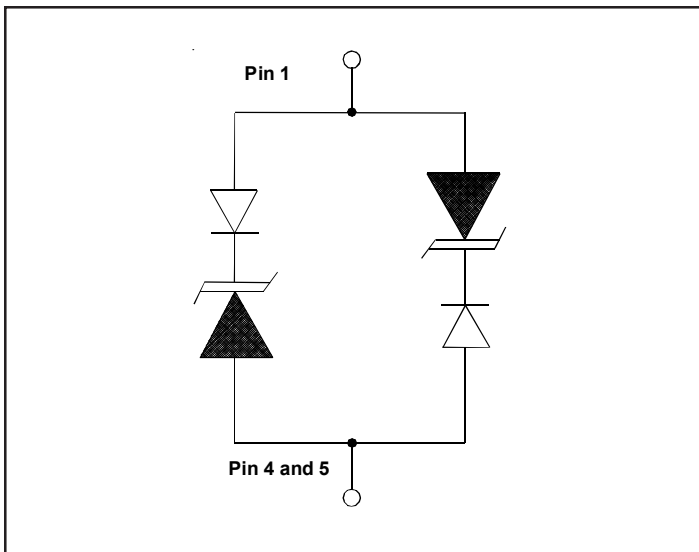

#### Schematic & PIN Configuration

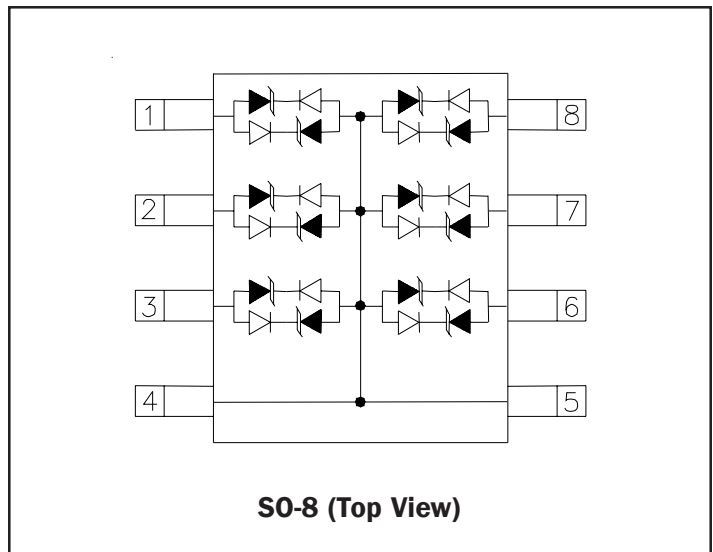

**PROTECTION PRODUCTS**
**Absolute Maximum Rating**

Rating	Symbol	Value	Units
Peak Pulse Power ( $t_p = 8/20\mu s$ )	$P_{pk}$	500	Watts
Peak Pulse Current ( $t_p = 8/20\mu s$ )	$I_{pp}$	15	A
Lead Soldering Temperature	$T_L$	260 (10 sec.)	°C
Operating Temperature	$T_J$	-55 to +125	°C
Storage Temperature	$T_{STG}$	-55 to +150	°C

**Electrical Characteristics**

LCDA15C-6						
Parameter	Symbol	Conditions	Minimum	Typical	Maximum	Units
Reverse Stand-Off Voltage	$V_{RWM}$				15	V
Reverse Breakdown Voltage	$V_{BR}$	$I_t = 1mA$	16.7			V
Reverse Leakage Current	$I_R$	$V_{RWM} = 15V, T=25^\circ C$			5	$\mu A$
Clamping Voltage	$V_C$	$I_{pp} = 1A, t_p = 8/20\mu s$ Line-to-Ground			24	V
Clamping Voltage	$V_C$	$I_{pp} = 15A, t_p = 8/20\mu s$ Line-to-Ground			33	V
Junction Capacitance	$C_J$	Between I/O pins and Ground $V_R = 0V, f = 1MHz$		8	15	pF
		Between I/O pins $V_R = 0V, f = 1MHz$		3		pF

PROTECTION PRODUCTS

Typical Characteristics

Non-Repetitive Peak Pulse Power vs. Pulse Time

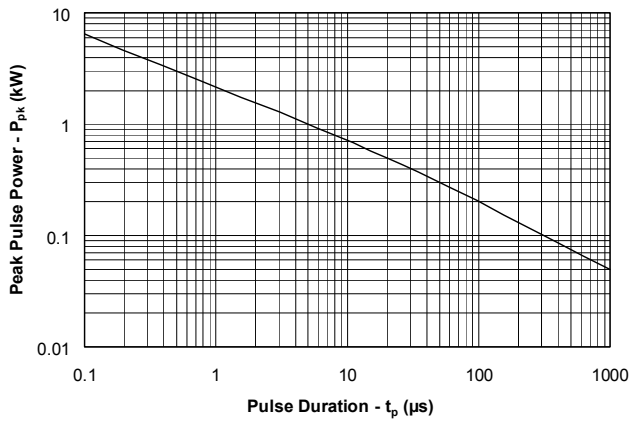

Power Derating Curve

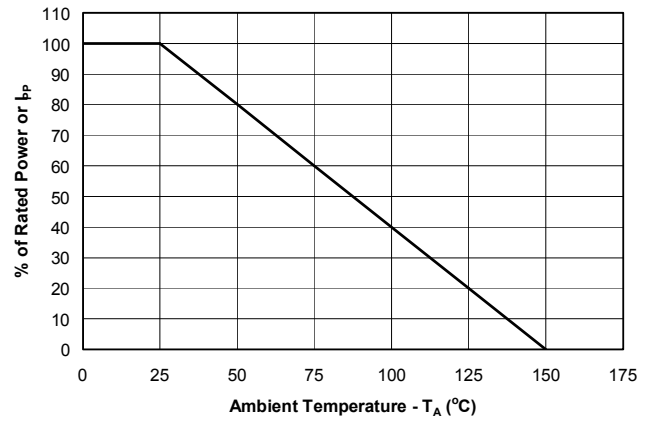

Pulse Waveform

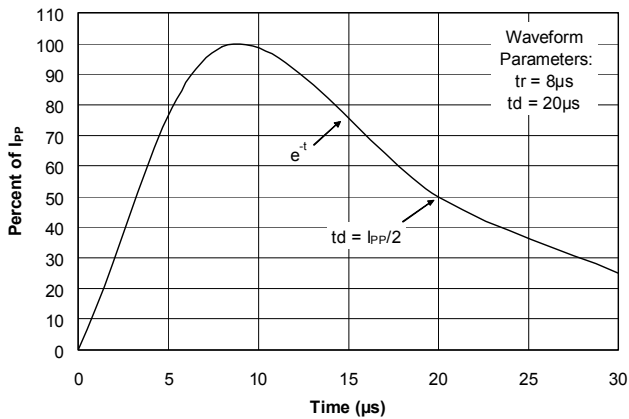

Clamping Voltage vs. Peak Pulse Current

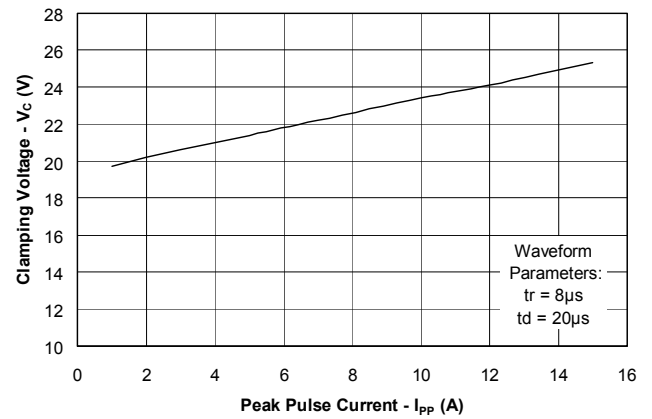

Capacitance vs. Reverse Voltage

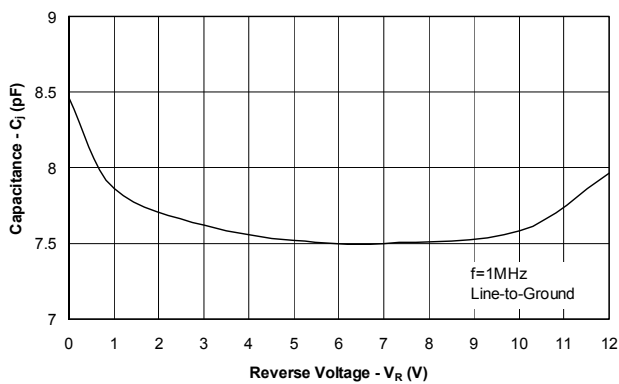

## PROTECTION PRODUCTS

### Applications Information

#### Device Connection Options for Protection of Six High-Speed Data Lines

The LCDA15C-6 may be configured to protect up to six I/O lines operating between 5 and 15V. It may be used to protect the most popular serial data interface standard lines making it ideal for use in equipment utilizing multi-mode transceivers. Data lines are connected at pins 1, 2, 3, 6, 7, and 8. Pins 4 and 5 are connected to ground. For best results, these pins should be connected directly to a ground plane on the board. The path length should be kept as short as possible to minimize parasitic inductance.

#### Multi-Mode Transceiver Protection

A typical multi-mode transceiver protection circuit is shown. The LCDA15C-6 is used to protect I/O lines with external connections. The LCDA15C-6 adds a maximum loading capacitance of 15pF with a working voltage of 15V. This allows the transceiver to safely operate in all modes without clipping or degradation of the signal.

With proper design and layout, the transceiver port can be protected to >15kV (HBM per IEC 61000-4-2).

#### Circuit Board Layout Recommendations for Suppression of ESD.

Good circuit board layout is critical for the suppression of fast rise-time transients such as ESD. The following guidelines are recommended:

- Place the LCDA15C-6 near the input terminals or connectors to restrict transient coupling.
- Minimize the path length between the LCDA15C-6 and the protected line.
- Minimize all conductive loops including power and ground loops.
- The ESD transient return path to ground should be kept as short as possible.
- Never run critical signals near board edges.
- Use ground planes whenever possible.

#### Device Connection

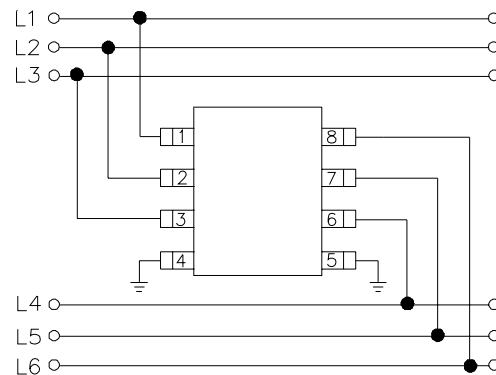

#### Multi-Mode Transceiver Protection Example

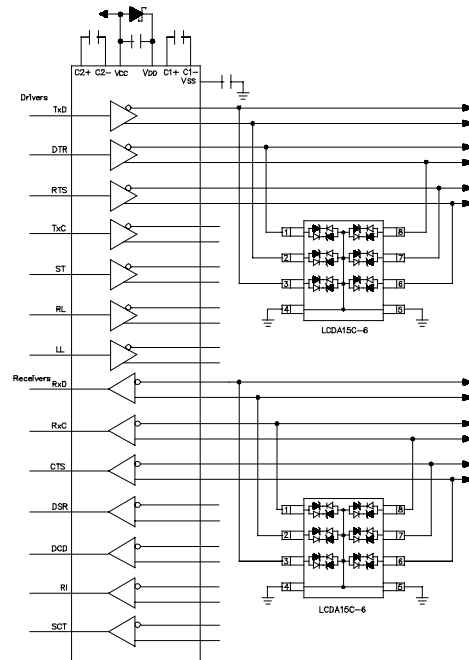

#### Matte Tin Lead Finish

Matte tin has become the industry standard lead-free replacement for SnPb lead finishes. A matte tin finish is composed of 100% tin solder with large grains. Since the solder volume on the leads is small compared to the solder paste volume that is placed on the land pattern of the PCB, the reflow profile will be determined by the requirements of the solder paste. Therefore, these devices are compatible with both lead-free and SnPb assembly techniques. In addition, unlike other lead-free compositions, matte tin does not have any added alloys that can cause degradation of the solder joint.



**PROTECTION PRODUCTS****Ordering Information**

<b>Part Number</b>	<b>Lead Finish</b>	<b>Qty per Reel</b>	<b>Reel Size</b>
LCDA15C-6.TB	SnPb	500	7 Inch
LCDA15.C-6TBT	Pb Free	500	7 inch
LCDA15C-6	SnPb	95/Tube	N/A
LCDA15C-6.T	Pb Free	95/Tube	N/A

Note: Lead-free devices are RoHS/WEEE Compliant

**Contact Information**

Semtech Corporation  
Protection Products Division  
200 Flynn Rd., Camarillo, CA 93012  
Phone: (805)498-2111 FAX (805)498-3804

## X-ON Electronics

Largest Supplier of Electrical and Electronic Components

*Click to view similar products for [ESD Suppressors / TVS Diodes](#) category:*

*Click to view products by [Semtech](#) manufacturer:*

Other Similar products are found below :

[60KS200C](#) [D12V0H1U2WS-7](#) [D18V0L1B2LP-7B](#) [82356050220](#) [D5V0M5U6V-7](#) [NTE4902](#) [P4KE27CA](#) [P6KE11CA](#) [P6KE39CA-TP](#)  
[P6KE8.2A](#) [SA110CA](#) [SA60CA](#) [SA64CA](#) [SMBJ12CATR](#) [SMBJ8.0A](#) [SMLJ30CA-TP](#) [ESD101-B1-02ELS E6327](#) [ESD112-B1-02EL E6327](#)  
[ESD119B1W01005E6327XTSA1](#) [ESD5V0L1B02VH6327XTSA1](#) [ESD7451N2T5G](#) [19180-510](#) [CPDT-5V0USP-HF](#) [3.0SMCJ33CA-F](#)  
[3.0SMCJ36A-F](#) [HSPC16701B02TP](#) [D3V3Q1B2DLP3-7](#) [D55V0M1B2WS-7](#) [DESD5V0U1BL-7B](#) [DRTR5V0U4SL-7](#) [SCM1293A-04SO](#)  
[ESD200-B1-CSP0201 E6327](#) [ESD203-B1-02EL E6327](#) [SM12-7](#) [SMF8.0A-TP](#) [SMLJ45CA-TP](#) [CEN955 W/DATA](#) [82350120560](#)  
[82356240030](#) [VESD12A1A-HD1-GS08](#) [CPDUR5V0R-HF](#) [CPDUR24V-HF](#) [CPDQC5V0U-HF](#) [CPDQC5V0USP-HF](#) [CPDQC5V0-HF](#)  
[D1213A-01LP4-7B](#) [D1213A-02WL-7](#) [ESDLIN1524BJ-HQ](#) [5KP100A](#) [5KP15A](#)