

**PROTECTION PRODUCTS - RailClamp®**
**Description**

RailClamp® TVS arrays are low capacitance ESD protection devices designed to protect high speed data interfaces.. This series has been specifically designed to protect sensitive components which are connected to data and transmission lines from overvoltage caused by **ESD** (electrostatic discharge), **CDE** (Cable Discharge Events), and **EFT** (electrical fast transients).

The unique design incorporates surge rated, low capacitance steering diodes and a TVS diode in a single package. During transient conditions, the steering diodes direct the transient to either the positive side of the power supply line or to ground. The internal TVS diode prevents over-voltage on the power line, protecting any downstream components.

The low capacitance array configuration allows the user to protect three high-speed data or transmission lines. The low inductance construction minimizes voltage overshoot during high current surges. This device is optimized for ESD protection of USB OTG and SIM interfaces. They may be used to meet the ESD immunity requirements of IEC 61000-4-2, Level 4 ( $\pm 15\text{kV}$  air,  $\pm 8\text{kV}$  contact discharge).

**Features**

- ◆ Transient protection for high-speed data lines to **IEC 61000-4-2 (ESD)  $\pm 25\text{kV}$  (air),  $\pm 20\text{kV}$  (contact)**  
**IEC 61000-4-4 (EFT) 40A (5/50ns)**
- ◆ Array of surge rated diodes with internal TVS Diode
- ◆ Small package saves board space
- ◆ Protects three I/O lines & power line
- ◆ Low capacitance ( **$< 3\text{pF}$** ) for high-speed interfaces
- ◆ Low clamping voltage
- ◆ Low operating voltage: 5.0V
- ◆ Solid-state silicon-avalanche technology

**Mechanical Characteristics**

- ◆ EIAJ SC-70 5L package
- ◆ Molding compound flammability rating: UL 94V-0
- ◆ Lead Finish: Matte Tin
- ◆ Pb-Free, Halogen Free, RoHS/WEEE Compliant
- ◆ Marking : F53
- ◆ Packaging : Tape and Reel

**Applications**

- ◆ USB OTG interfaces
- ◆ SIM Ports
- ◆ Video Graphics Cards
- ◆ Personal Digital Assistants (PDAs)
- ◆ Monitors and Flat Panel Displays
- ◆ Portable Electronics
- ◆ Microcontroller Input Protection

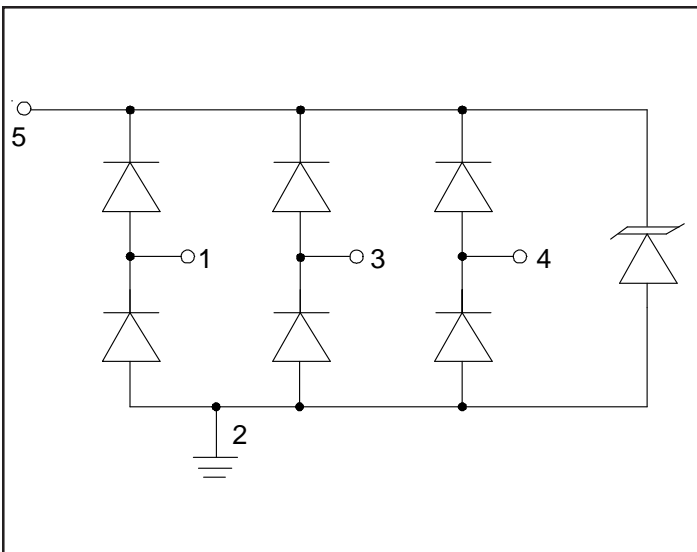
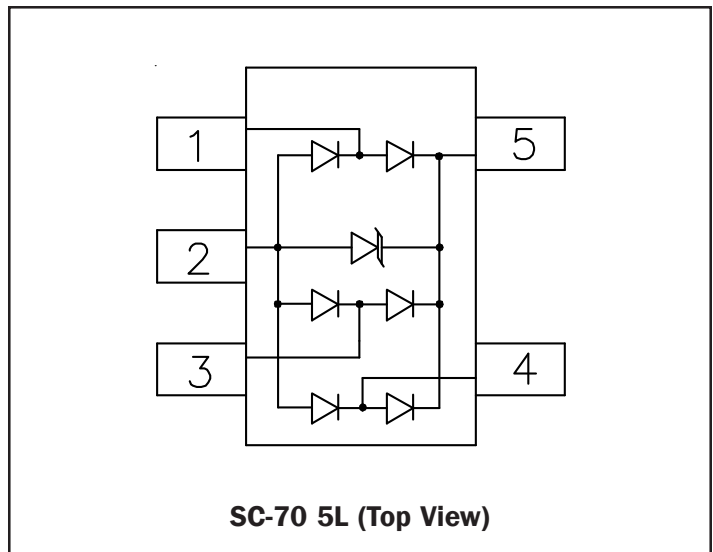
**Schematic**

**Schematic & PIN Configuration**

**PROTECTION PRODUCTS**
**Absolute Maximum Rating**

Rating	Symbol	Value	Units
Peak Pulse Power (tp = 8/20μs)	$P_{pk}$	150	Watts
Maximum Peak Pulse Current (tp = 8/20μs)	$I_{pp}$	6	Amps
ESD per IEC 61000-4-2 (Air) <sup>1</sup> ESD per IEC 61000-4-2 (Contact) <sup>1</sup>	$V_{ESD}$	+/- 25 +/- 20	kV
Operating Temperature	$T_J$	-55 to +125	°C
Storage Temperature	$T_{STG}$	-55 to +150	°C

**Electrical Characteristics (T=25°C)**

Parameter	Symbol	Conditions	Minimum	Typical	Maximum	Units
Reverse Stand-Off Voltage	$V_{RWM}$	Pin 5 to 2			5	V
Reverse Breakdown Voltage	$V_{BR}$	$I_t = 1mA$ Pin 5 to 2	6			V
Reverse Leakage Current	$I_R$	$V_{RWM} = 5V, T=25°C$ Pin 5 to 2			3	μA
Clamping Voltage	$V_C$	$I_{pp} = 1A, tp = 8/20μs$ Pin 1, 3, or 4 to Pin 2			15	V
Clamping Voltage	$V_C$	$I_{pp} = 6A, tp = 8/20μs$ Pin 1, 3, or 4 to Pin 2			25	V
Junction Capacitance	$C_J$	$V_R = 0V, f = 1MHz$ Pin 1, 3, or 4 to Pin 2			3	pF
		$V_R = 0V, f = 1MHz$ Between any two I/O pins (1, 3, 4)			1.5	pF

**Notes**

1)ESD gun return path connected to ESD ground reference plane.

## PROTECTION PRODUCTS

### Typical Characteristics

**Non-Repetitive Peak Pulse Power vs. Pulse Time**

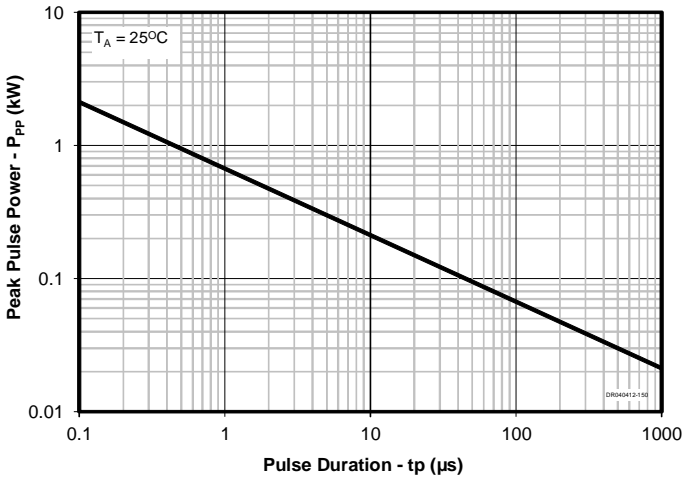

**Junction Capacitance vs. Reverse Voltage  
(Pin 1, 3, or 4 to GND - Normalized to 0V)**

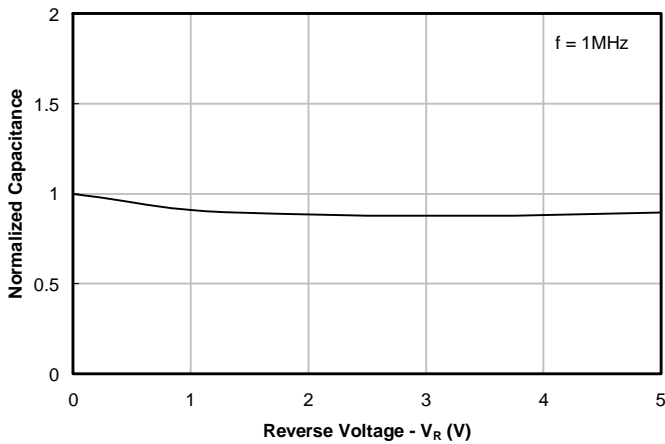

**ESD Clamping (+8kV Contact per IEC 61000-4-2)  
(Pin 1, 3, or 4 to GND)**

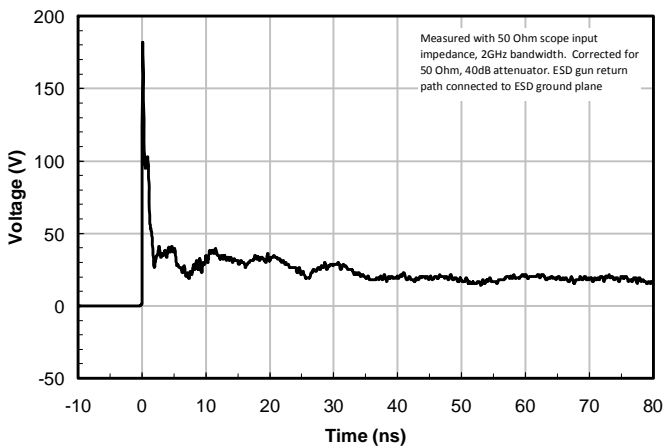

**Clamping Voltage vs. Peak Pulse Current ( $t_p=8/20\mu$ s)**

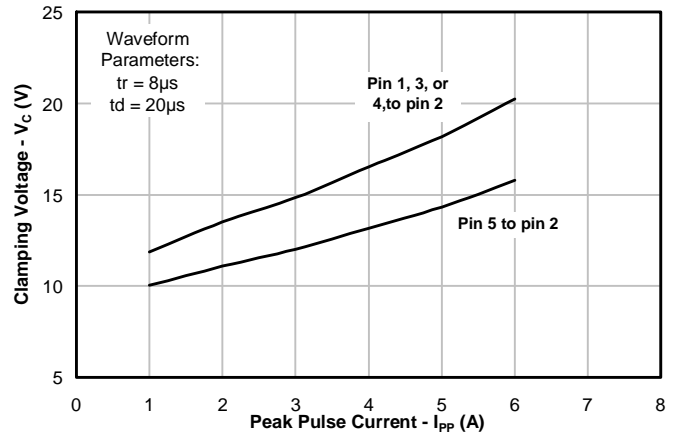

**TLP Characteristic  
(Pin 1, 3, or 4 to GND)**

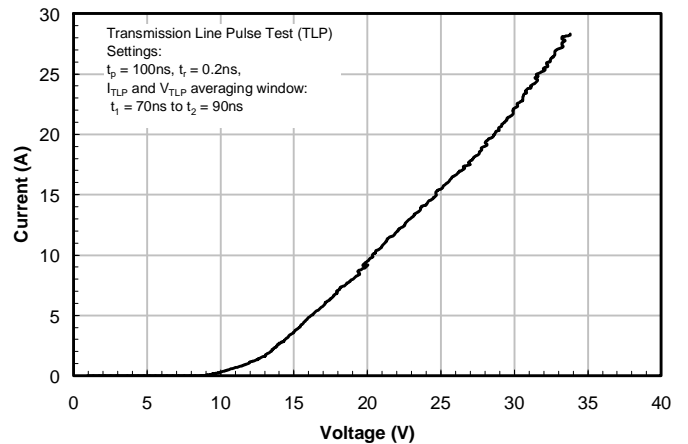

**ESD Clamping (-8kV Contact per IEC 61000-4-2)  
(Pin 1, 3, or 4 to GND)**

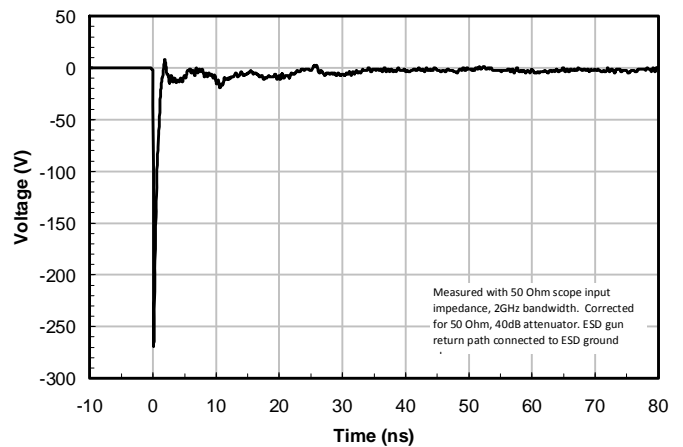

## PROTECTION PRODUCTS

## Typical Characteristics

**Insertion Loss S21  
(Pin 1, 3, or 4 to GND)**

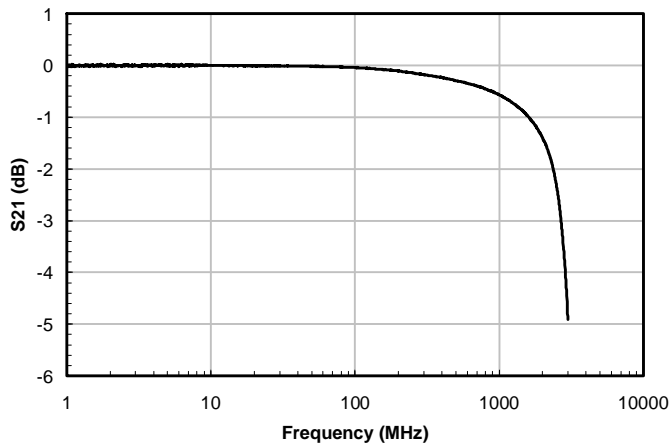

**Insertion Loss S21  
(Between any two I/O pins - 1, 3, 4)**

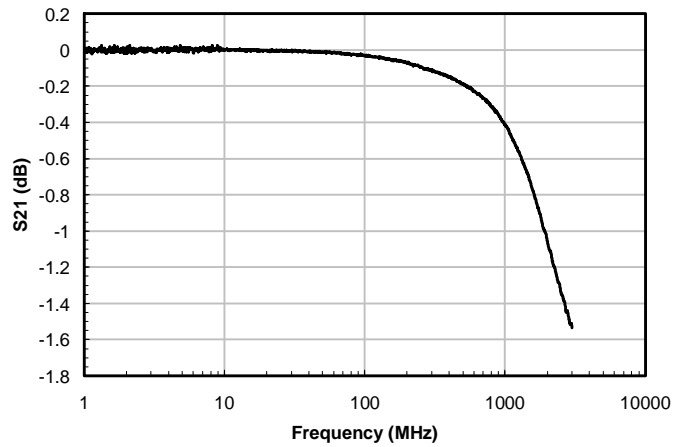

## PROTECTION PRODUCTS

### Applications Information

#### Device Connection Options for Protection of Three High-Speed Data Lines

This device is designed to protect three data lines from transient over-voltages by clamping them to a fixed reference. When the voltage on the protected line exceeds the reference voltage (plus diode  $V_f$ ) the steering diodes are forward biased, conducting the transient current away from the sensitive circuitry. Data lines are connected at pins 1, 3, and 4. The negative reference is connected at pin 2. This pin should be connected directly to a ground plane on the board for best results. The path length is kept as short as possible to minimize parasitic inductance. Connect pin 5 directly to the positive supply rail ( $V_{CC}$ ). In this configuration the data lines are referenced to the supply voltage. The internal TVS diode prevents over-voltage on the supply rail.

#### Matte Tin Lead Finish

Matte tin has become the industry standard lead-free replacement for SnPb lead finishes. A matte tin finish is composed of 100% tin solder with large grains. Since the solder volume on the leads is small compared to the solder paste volume that is placed on the land pattern of the PCB, the reflow profile will be determined by the requirements of the solder paste. Therefore, these devices are compatible with both lead-free and SnPb assembly techniques. In addition, unlike other lead-free compositions, matte tin does not have any added alloys that can cause degradation of the solder joint.

#### Data Line and Power Supply Protection Using $V_{CC}$ as reference

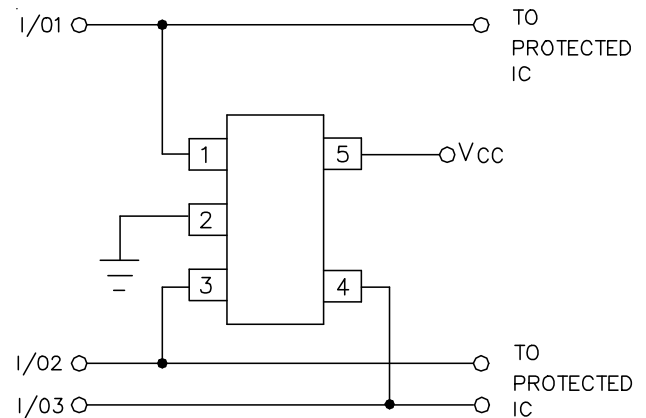



## PROTECTION PRODUCTS

### Marking Code

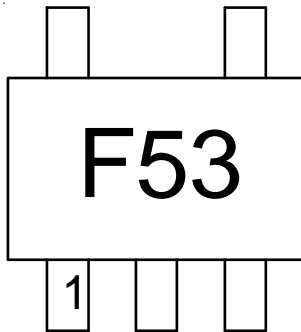

### Ordering Information

Part Number	Lead Finish	Qty per Reel	Reel Size
RClamp0503F.TCT	Matte Tin	3,000	7 Inch

RailClamp and RClamp are trademarks of Semtech Corporation.

### Carrier Tape Specification

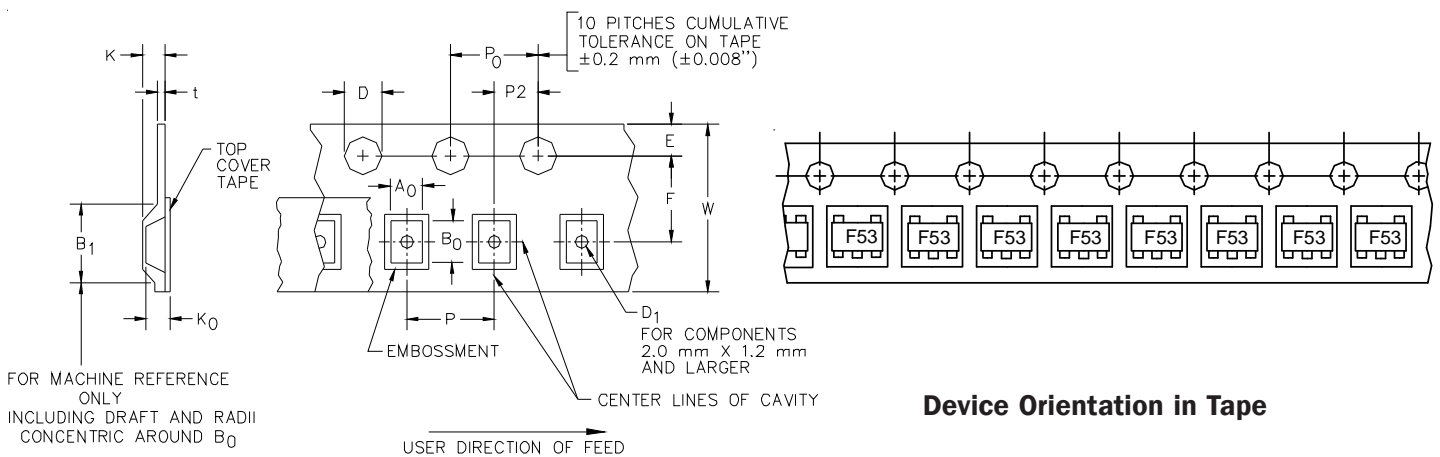

**Device Orientation in Tape**

Tape Width	B, (Max)	D	D1 (MIN)	E	F	K (MAX)	P	P0	P2	T(MAX)	W
8 mm	4.2 mm (.165)	1.5 + 0.1 mm - 0.0 mm (0.59 +.005 -.000)	1.0 mm (.039)	1.750±.10 mm (.069±.004)	3.5±0.05 mm (.138±.002)	2.4 mm (.094)	4.0±0.1 mm (.157±.00- 4)	4.0±0.1 mm (.157±.00- 4)	2.0±0.05m- m (.079±.002)	0.4 mm (.016)	8.3 mm (.312±.012)

### Contact Information

Semtech Corporation  
 Protection Products Division  
 200 Flynn Rd., Camarillo, CA 93012  
 Phone: (805)498-2111 FAX (805)498-3804

## X-ON Electronics

Largest Supplier of Electrical and Electronic Components

*Click to view similar products for [ESD Suppressors / TVS Diodes](#) category:*

*Click to view products by [Semtech](#) manufacturer:*

Other Similar products are found below :

[60KS200C](#) [D12V0H1U2WS-7](#) [D18V0L1B2LP-7B](#) [82356050220](#) [D5V0M5U6V-7](#) [NTE4902](#) [P4KE27CA](#) [P6KE11CA](#) [P6KE39CA-TP](#)  
[P6KE8.2A](#) [SA110CA](#) [SA60CA](#) [SA64CA](#) [SMBJ12CATR](#) [SMBJ8.0A](#) [SMLJ30CA-TP](#) [ESD101-B1-02ELS E6327](#) [ESD112-B1-02EL E6327](#)  
[ESD119B1W01005E6327XTSA1](#) [ESD5V0L1B02VH6327XTSA1](#) [ESD7451N2T5G](#) [19180-510](#) [CPDT-5V0USP-HF](#) [3.0SMCJ33CA-F](#)  
[3.0SMCJ36A-F](#) [HSPC16701B02TP](#) [D3V3Q1B2DLP3-7](#) [D55V0M1B2WS-7](#) [DESD5V0U1BL-7B](#) [DRTR5V0U4SL-7](#) [SCM1293A-04SO](#)  
[ESD200-B1-CSP0201 E6327](#) [ESD203-B1-02EL E6327](#) [SM12-7](#) [SMF8.0A-TP](#) [SMLJ45CA-TP](#) [CEN955 W/DATA](#) [82350120560](#)  
[82356240030](#) [VESD12A1A-HD1-GS08](#) [CPDUR5V0R-HF](#) [CPDUR24V-HF](#) [CPDQC5V0U-HF](#) [CPDQC5V0USP-HF](#) [CPDQC5V0-HF](#)  
[D1213A-01LP4-7B](#) [D1213A-02WL-7](#) [ESDLIN1524BJ-HQ](#) [5KP100A](#) [5KP15A](#)