

PROTECTION PRODUCTS - RailClamp®
Description

RailClamps are surge rated diode arrays designed to protect high speed data interfaces. The RClamp series has been specifically designed to protect sensitive components which are connected to data and transmission lines from overvoltage caused by electrostatic discharge (**ESD**), electrical fast transients (**EFT**), and **lightning**.

The unique design of the RClamp series devices incorporates eight surge rated, low capacitance steering diodes and a TVS in a single package. During transient conditions, the steering diodes direct the transient to either the positive side of the power supply line or to ground. The internal TVS diode prevents over-voltage on the power line, protecting any downstream components.

The RClamp™0504N has a low typical capacitance of 3pF and operates with virtually no insertion loss to 1GHz. This makes the device ideal for protection of high-speed data lines such as USB 2.0, Firewire, DVI, and gigabit Ethernet interfaces.

The RClamp0504N is in a 6-pin, RoHS compliant, SLP2020P6 package. It measures 2.0 x 2.0 x 0.60mm. The leads are spaced at a pitch of 0.5mm and are finished with lead-free NiPdAu. Each device may be used to protect four high-speed data or transmission lines. They may be used to meet the ESD immunity requirements of IEC 61000-4-2, Level 4 ($\pm 15\text{kV}$ air, $\pm 8\text{kV}$ contact discharge).

Features

- ◆ ESD protection for high-speed data lines to **IEC 61000-4-2 (ESD) $\pm 15\text{kV}$ (air), $\pm 8\text{kV}$ (contact)**
- ◆ **IEC 61000-4-4 (EFT) 40A (5/50ns)**
- ◆ **IEC 61000-4-5 (Lightning) 12A (8/20 μs)**
- ◆ Array of surge rated diodes with internal TVS Diode
- ◆ Small package saves board space
- ◆ Protects four I/O lines
- ◆ Low capacitance: **3pF** typical
- ◆ Low clamping voltage
- ◆ Low operating voltage: 5.0V
- ◆ Solid-state silicon-avalanche technology

Mechanical Characteristics

- ◆ SLP2020P6 Package
- ◆ RoHS/WEEE Compliant
- ◆ Nominal Dimensions: 2.0 x 2.0 x 0.60 mm
- ◆ Lead Pitch: 0.65mm
- ◆ Lead Finish: NiPdAu
- ◆ Marking : Marking Code and Date Code
- ◆ Packaging : Tape and Reel

Applications

- ◆ USB 2.0 Power and Data Line Protection
- ◆ Video Graphics Cards
- ◆ Monitors and Flat Panel Displays
- ◆ Digital Video Interface (DVI)
- ◆ 10/100/1000 Ethernet
- ◆ Notebook Computers

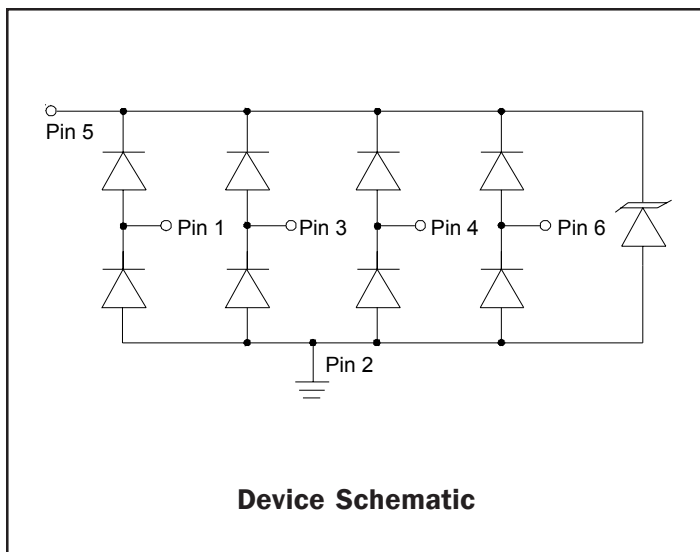
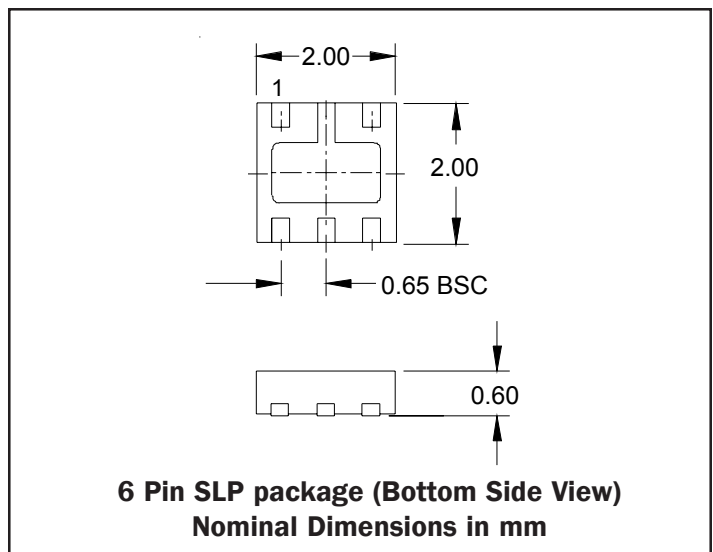
Circuit Diagram

Package Dimensions

PROTECTION PRODUCTS
Absolute Maximum Rating

Rating	Symbol	Value	Units
Peak Pulse Power (tp = 8/20μs)	P_{pk}	300	Watts
Peak Pulse Current (tp = 8/20μs)	I_{pp}	12	A
ESD per IEC 61000-4-2 (Air) ESD per IEC 61000-4-2 (Contact)	V_{ESD}	15 8	kV
Operating Temperature	T_J	-55 to +125	°C
Storage Temperature	T_{STG}	-55 to +150	°C

Electrical Characteristics (T = 25°C)

RClamp0504N						
Parameter	Symbol	Conditions	Minimum	Typical	Maximum	Units
Reverse Stand-Off Voltage	V_{RWM}	Pin 5 to 2			5	V
Reverse Breakdown Voltage	V_{BR}	$I_t = 1mA$ Pin 5 to 2	6			V
Reverse Leakage Current	I_R	$V_{RWM} = 5V, T=25°C$ Pin 5 to 2			5	μA
Forward Voltage	V_F	$I_f = 15mA$			1.2	V
Clamping Voltage	V_C	$I_{pp} = 1A, tp = 8/20μs$ Any I/O pin to Ground			12.5	V
Clamping Voltage	V_C	$I_{pp} = 5A, tp = 8/20μs$ Any I/O pin to Ground			17.5	V
Junction Capacitance	C_j	$V_R = 0V, f = 1MHz$ Any I/O pin to Ground		3	5	pF
		$V_R = 0V, f = 1MHz$ Between I/O pins		1.5		pF

PROTECTION PRODUCTS

Typical Characteristics

Non-Repetitive Peak Pulse Power vs. Pulse Time

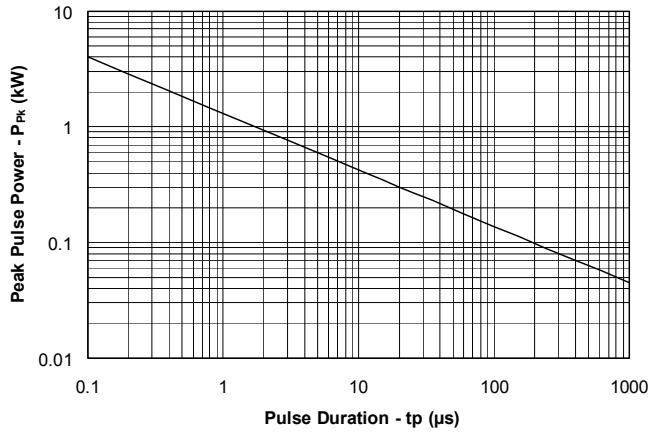

Power Derating Curve

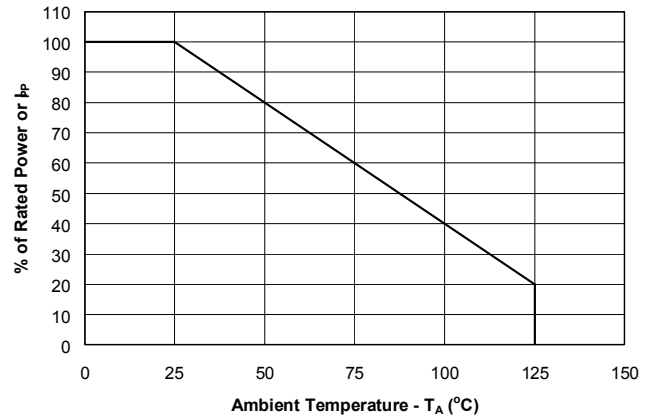

Pulse Waveform

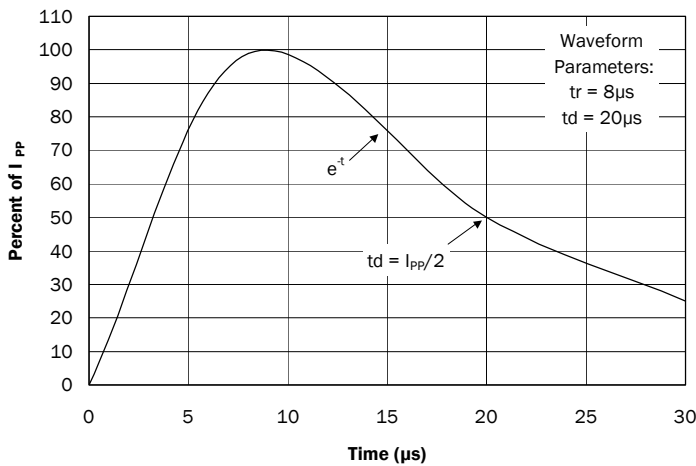

Clamping Voltage vs. Peak Pulse Current

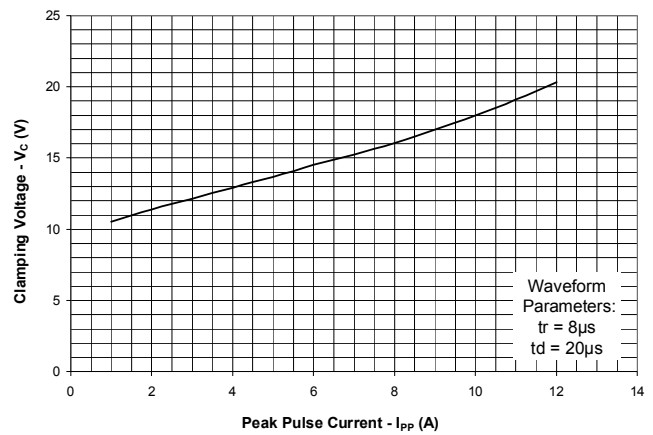

Forward Voltage vs. Forward Current

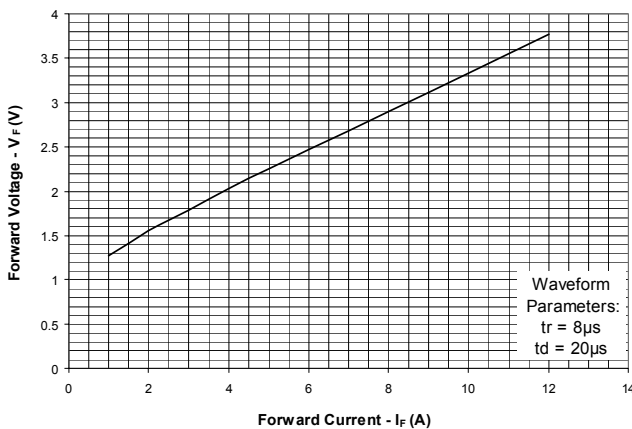

Normalized Capacitance vs. Reverse Voltage

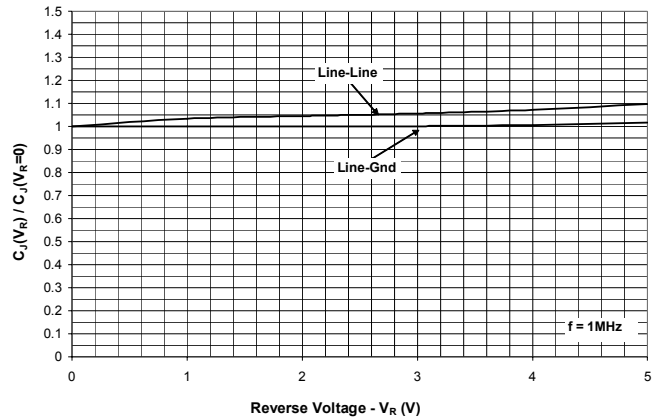

PROTECTION PRODUCTS

Applications Information

Device Connection Options for Protection of Four High-Speed Data Lines

This device is designed to protect four data lines from transient over-voltages by clamping them to a fixed reference. When the voltage on the protected line exceeds the reference voltage (plus diode V_F) the steering diodes are forward biased, conducting the transient current away from the sensitive circuitry. Data lines are connected at pins 1, 3, 4 and 6. The negative reference is connected at pin 2. This pin should be connected directly to a ground plane on the board for best results. The path length is kept as short as possible to minimize parasitic inductance. The positive reference is connected at pin 5. The options for connecting the positive reference are as follows:

1. To protect data lines and the power line, connect pin 5 directly to the positive supply rail (V_{CC}). In this configuration the data lines are referenced to the supply voltage. The internal TVS diode prevents over-voltage on the supply rail.

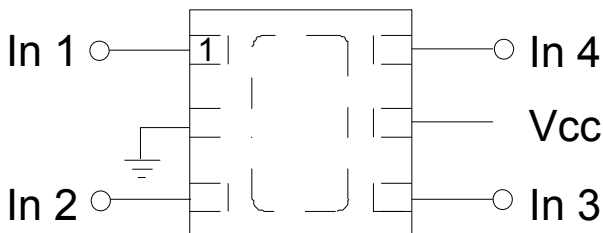

2. In applications where the supply rail does not exit the system, the internal TVS may be used as the reference. In this case, pin 5 is not connected. The steering diodes will begin to conduct when the voltage on the protected line exceeds the working voltage of the TVS (plus one diode drop).

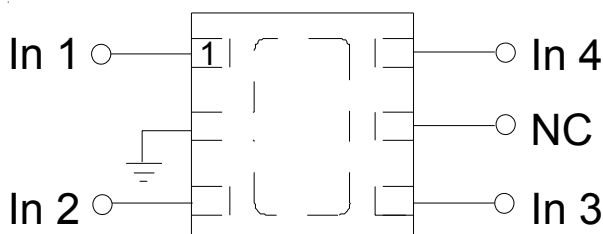

ESD Protection With RailClamps®

RailClamps are optimized for ESD protection using the rail-to-rail topology. Along with good board layout, these devices virtually eliminate the disadvantages of using discrete components to implement this topology. Consider the situation shown in Figure 1 where discrete diodes or diode arrays are configured for rail-to-rail protection on a high speed line. During positive duration ESD events, the top diode will be forward biased when the voltage on the protected line exceeds the reference voltage plus the V_F drop of the diode. For negative events, the bottom diode will be biased when the voltage exceeds the V_F of the diode. At first approximation, the clamping voltage due to the characteristics of the protection diodes is given by:

$$V_C = V_{CC} + V_F \quad (\text{for positive duration pulses})$$

$$V_C = -V_F \quad (\text{for negative duration pulses})$$

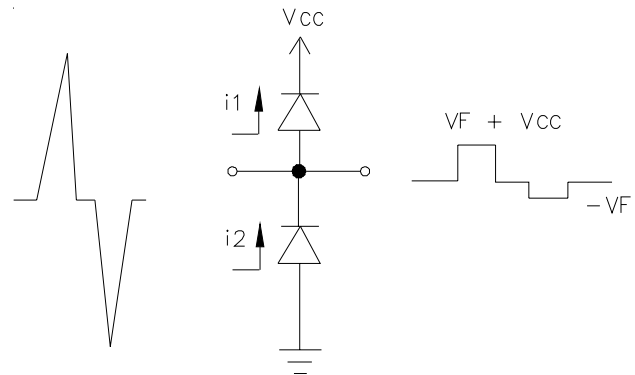

Figure 1 - "Rail-To-Rail" Protection Topology (First Approximation)

However, for fast rise time transient events, the effects of parasitic inductance must also be considered as shown in Figure 2. Therefore, the actual clamping voltage seen by the protected circuit will be:

$$V_C = V_{CC} + V_F + L_P \frac{di_{ESD}}{dt} \quad (\text{for positive duration pulses})$$

$$V_C = -V_F - L_G \frac{di_{ESD}}{dt} \quad (\text{for negative duration pulses})$$

ESD current reaches a peak amplitude of 30A in 1ns for a level 4 ESD contact discharge per IEC 61000-4-2.

PROTECTION PRODUCTS

Applications Information (continued)

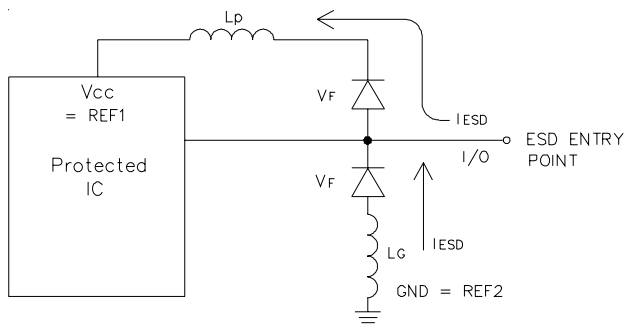

Figure 2 - The Effects of Parasitic Inductance When Using Discrete Components to Implement Rail-To-Rail Protection

Therefore, the voltage overshoot due to 1nH of series inductance is:

$$V = L_p \frac{di_{ESD}}{dt} = 1 \times 10^{-9} (30 / 1 \times 10^{-9}) = 30V$$

Example:

Consider a $V_{CC} = 5V$, a typical V_F of 30V (at 30A) for the steering diode and a series trace inductance of 10nH. The clamping voltage seen by the protected IC for a positive 8kV (30A) ESD pulse will be:

$$V_c = 5V + 30V + (10nH \times 30V/nH) = 335V$$

This does not take into account that the ESD current is directed into the supply rail, potentially damaging any components that are attached to that rail. Also note that it is not uncommon for the V_F of discrete diodes to exceed the damage threshold of the protected IC. This is due to the relatively small junction area of typical discrete components. It is also possible that the power dissipation capability of the discrete diode will be exceeded, thus destroying the device.

The RailClamp is designed to overcome the inherent disadvantages of using discrete signal diodes for ESD suppression. The RailClamp's integrated TVS diode helps to mitigate the effects of parasitic inductance in the power supply connection. During an ESD event, the current will be directed through the integrated TVS diode to ground. The maximum voltage seen by the protected IC due to this path will be the clamping voltage of the device.

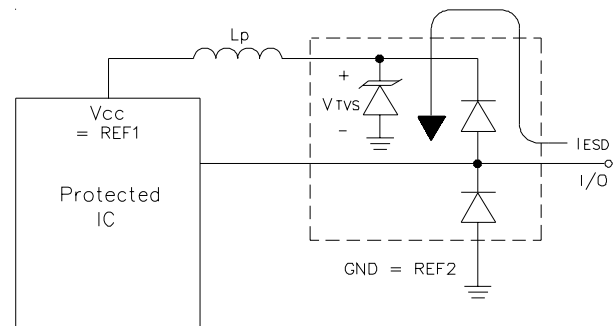

Figure 3 - Rail-To-Rail Protection Using RailClamp TVS Arrays

ETHERNET PROTECTION

Ethernet ICs are vulnerable to damage from electrostatic discharge (ESD), lightning, and cable discharge events (CDE). The internal protection in the PHY chip, if any, often is not enough due to the high energy of these disturbances. The fatal discharge can occur differentially across the transmit or receive line pair or between any line and ground (common mode).

Common mode and differential mode protection against ESD and CDE discharges can be achieved by connecting the RClamp0504N on the PHY side of the Ethernet circuit as shown in Figure 4. Pins 1, 3, 4, and 6 are connected to the transmit and receive line pairs. Since there is no V_{CC} connection at the connector, pin 5 of the RClamp0504N should not be connected. Pin 2 is connected to ground. This connection should be made directly to the ground plane. All path lengths should be kept as short as possible to minimize parasitic inductance. This configuration can be used to meet the ESD immunity requirements of IEC 61000-4-2 and cable discharge events.

PROTECTION PRODUCTS

Applications Information (continued)

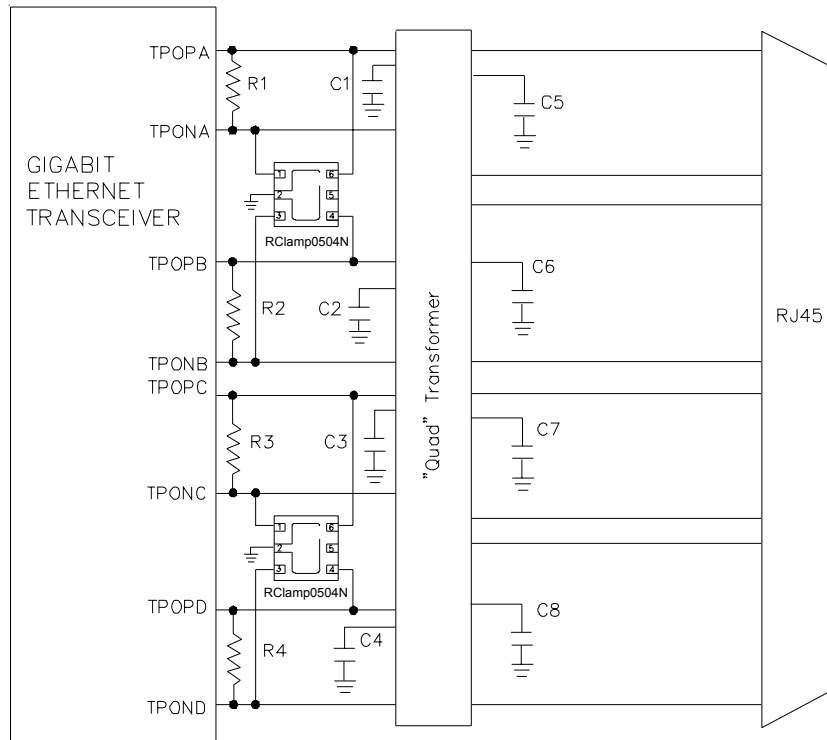
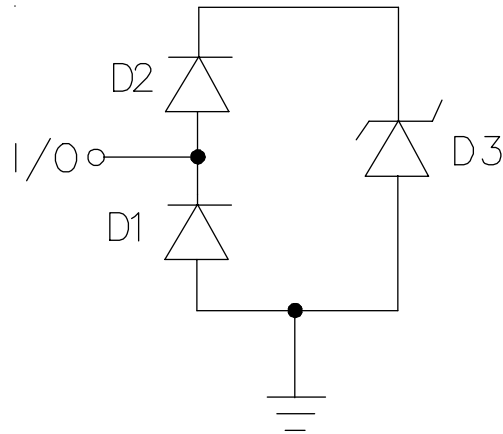

Figure 4 - 10/100/1000 Ethernet Protection to IEC 61000-4-2

PROTECTION PRODUCTS

Applications Information - Spice Model



RClamp0504N Spice Model

RClamp0504N Spice Parameters				
Parameter	Unit	D1 (LCRD)	D2 (LCRD)	D3 (TVS)
IS	Amp	1E-20	1E-20	8.57E-14
BV	Volt	180	20	8
VJ	Volt	0.63	0.59	0.66
RS	Ohm	0.195	0.357	0.512
IBV	Amp	1E-3	1E-3	1E-3
CJO	Farad	2E-12	2E-12	277E-12
TT	sec	2.541E-9	2.541E-9	2.541E-9
M	--	0.01	0.01	0.231
N	--	1.1	1.1	1.1
EG	eV	1.11	1.11	1.11

PROTECTION PRODUCTS

Outline Drawing -SLP2020P6

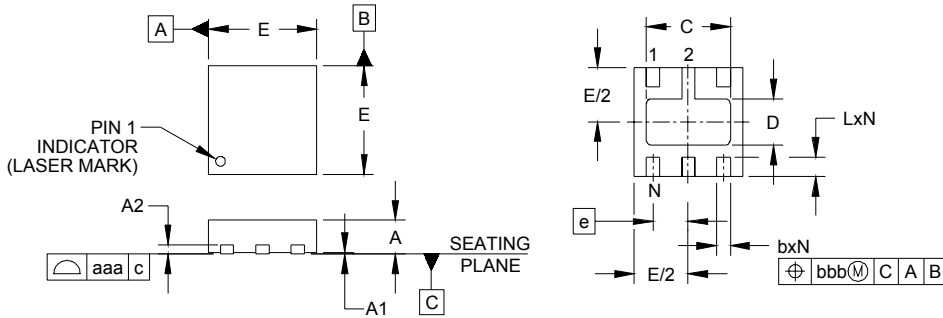

DIM	INCHES			MILLIMETERS		
	MIN	NOM	MAX	MIN	NOM	MAX
A	.020	.024	.026	0.50	0.60	0.65
A1	.000	.001	.002	0.00	0.03	0.05
A2	(.007)			(0.17)		
b	.007	.010	.012	0.20	0.25	0.30
C	.055	.061	.065	1.40	1.55	1.65
D	.028	.034	.038	0.71	0.86	0.96
E	.074	.079	.083	1.90	2.00	2.10
e	.025 BSC			0.65 BSC		
L	.011	.014	.016	0.30	0.35	0.40
N	6			6		
aaa	.003			0.08		
bbb	.003			0.08		

NOTES:

1. CONTROLLING DIMENSIONS ARE IN MILLIMETERS (ANGLES IN DEGREES).
2. COPLANARITY APPLIES TO THE EXPOSED PAD AS WELL AS THE TERMINALS.

Land Pattern -SLP2020P6

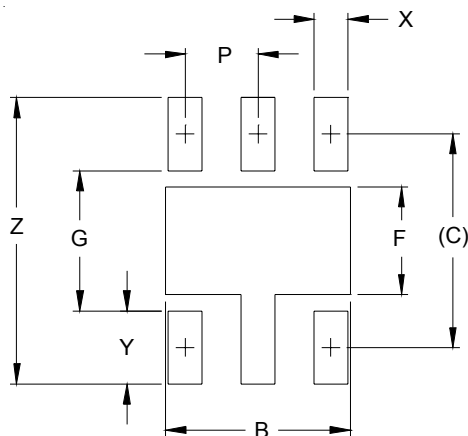

DIM	DIMENSIONS	
	INCHES	MILLIMETERS
B	.065	1.65
C	(.075)	(1.90)
F	.034	0.86
G	.049	1.25
P	.026	0.65
X	.014	0.35
Y	.026	0.65
Z	.100	2.55

NOTES:

1. THIS LAND PATTERN IS FOR REFERENCE PURPOSES ONLY. CONSULT YOUR MANUFACTURING GROUP TO ENSURE YOUR COMPANY'S MANUFACTURING GUIDELINES ARE MET.

PROTECTION PRODUCTS

Marking Codes

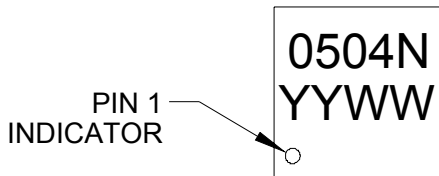

Ordering Information

Part Number	Working Voltage	Qty per Reel	Reel Size
RClamp0504N.TCT	5V	3,000	7 Inch

Notes:

- 1) This is a lead-free, RoHS compliant product
- RailClamp and RClamp are marks of Semtech Corporation

YYWW = Date Code (YY = Year, WW = Work Week)

Tape and Reel Specification

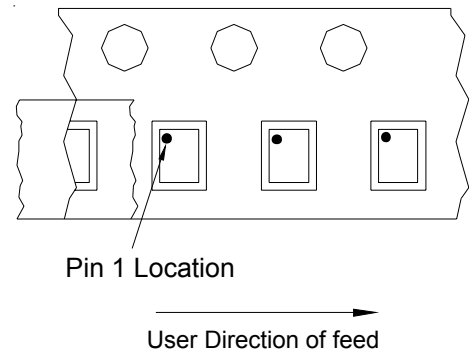
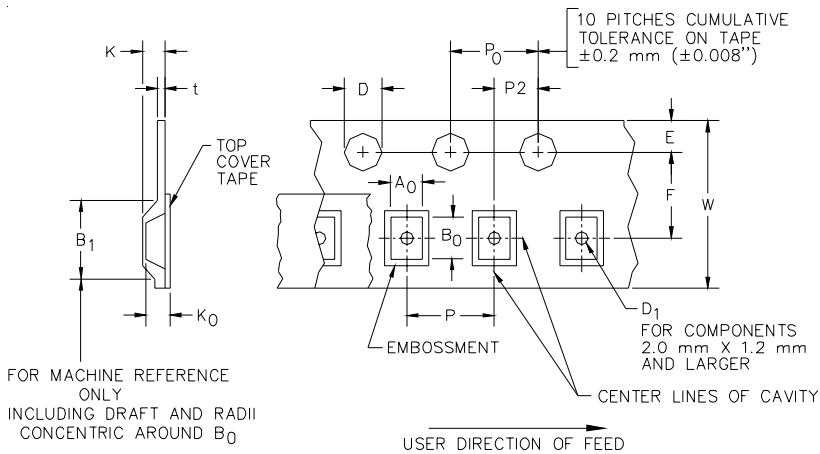

A0	B0	K0
2.25 +/-0.10 mm	2.25 +/-0.10 mm	0.75 +/-0.10 mm

Device Orientation in Tape

Tape Width	B, (Max)	D	D1	E	F	K (MAX)	P	P0	P2	T(MAX)	W
8 mm	4.2 mm (.165)	1.5 + 0.1 mm - 0.0 mm (0.59 +.005 - .000)	0.8 mm ±0.05 (.031)	1.750±.10 mm (.069±.004)	3.5±0.05 mm (.138±.002)	2.4 mm (.094)	4.0±0.1 mm (.157±.00-4)	4.0±0.1 mm (.157±.00-4)	2.0±0.05mm (.079±.002)	0.4 mm (.016)	8.0 mm + 0.3 mm - 0.1 mm (.312±.012)

Contact Information

Semtech Corporation
 Protection Products Division
 200 Flynn Road, Camarillo, CA 93012
 Phone: (805)498-2111 FAX (805)498-3804

X-ON Electronics

Largest Supplier of Electrical and Electronic Components

Click to view similar products for [ESD Suppressors / TVS Diodes](#) category:

Click to view products by [Semtech](#) manufacturer:

Other Similar products are found below :

[60KS200C](#) [D12V0H1U2WS-7](#) [D18V0L1B2LP-7B](#) [82356050220](#) [D5V0M5U6V-7](#) [NTE4902](#) [P4KE27CA](#) [P6KE11CA](#) [P6KE39CA-TP](#)
[P6KE8.2A](#) [SA110CA](#) [SA60CA](#) [SA64CA](#) [SMBJ12CATR](#) [SMBJ8.0A](#) [SMLJ30CA-TP](#) [ESD101-B1-02ELS E6327](#) [ESD112-B1-02EL E6327](#)
[ESD119B1W01005E6327XTSA1](#) [ESD5V0L1B02VH6327XTSA1](#) [ESD7451N2T5G](#) [19180-510](#) [CPDT-5V0USP-HF](#) [3.0SMCJ33CA-F](#)
[3.0SMCJ36A-F](#) [HSPC16701B02TP](#) [D3V3Q1B2DLP3-7](#) [D55V0M1B2WS-7](#) [DESD5V0U1BL-7B](#) [DRTR5V0U4SL-7](#) [SCM1293A-04SO](#)
[ESD200-B1-CSP0201 E6327](#) [ESD203-B1-02EL E6327](#) [SM12-7](#) [SMF8.0A-TP](#) [SMLJ45CA-TP](#) [CEN955 W/DATA](#) [82350120560](#)
[82356240030](#) [VESD12A1A-HD1-GS08](#) [CPDUR5V0R-HF](#) [CPDUR24V-HF](#) [CPDQC5V0U-HF](#) [CPDQC5V0USP-HF](#) [CPDQC5V0-HF](#)
[D1213A-01LP4-7B](#) [D1213A-02WL-7](#) [ESDLIN1524BJ-HQ](#) [5KP100A](#) [5KP15A](#)