

PROTECTION PRODUCTS - RailClamp®

Description

RailClamp® is a low capacitance TVS array designed to protect high speed data interfaces. This series has been specifically designed to protect sensitive components which are connected to data and transmission lines from overvoltage caused by **ESD** (electrostatic discharge), **CDE** (Cable Discharge Events), and **EFT** (electrical fast transients).

The RClamp0854P is specifically designed to protect portable devices that utilize the USB port for battery charging. The unique design of this device features low capacitance TVS diodes for protection of the USB data (DP, DM) and USB ID (accessory detect) pins operating up to 5.5 volts. Loading capacitance on these lines is <math><0.1\text{pF}</math> for maximum signal integrity. An integrated 5.5 volt TVS diode is used for protection of the USB voltage bus. This ensures the device will remain in a high-impedance state during normal USB operation or when the battery is being charged.

The RClamp0854P is in a 6-pin, RoHS compliant, SLP1616P6 package. It measures 1.6 x 1.6 x 0.60mm. The leads are spaced at a pitch of 0.5mm and are finished with lead-free NiPdAu. They may be used to meet the ESD immunity requirements of IEC 61000-4-2, Level 4 (15kV air, 8kV contact discharge).

Features

- ◆ Transient protection for high-speed data lines to **IEC 61000-4-2 (ESD) $\pm 15\text{kV}$ (air), $\pm 8\text{kV}$ (contact) IEC 61000-4-4 (EFT) 40A (5/50ns)**
- ◆ Array of surge rated diodes with internal TVS Diode
- ◆ Small package (1.6 x 1.6mm) saves board space
- ◆ Protects USB DP, DM, and ID Pin operating up to 5.5V
- ◆ Protects USB VBus operating up to 5.5V
- ◆ Low capacitance (**<math><1\text{pF}</math>**) on DP, DM, and ID Pins
- ◆ No insertion loss to **2.0GHz**
- ◆ Low leakage current
- ◆ Low clamping voltage
- ◆ Large ground pad for increased ESD performance
- ◆ Solid-state silicon-avalanche technology

Mechanical Characteristics

- ◆ SLP1616P6 6L package
- ◆ RoHS/WEEE Compliant
- ◆ Nominal Dimensions: 1.6 x 1.6 x 0.60 mm
- ◆ Lead Finish: NiPdAu
- ◆ Molding compound flammability rating: UL 94V-0
- ◆ Marking : Marking code + two character date code
- ◆ Packaging : Tape and Reel

Applications

- ◆ USB 2.0
- ◆ USB OTG

Circuit Diagram

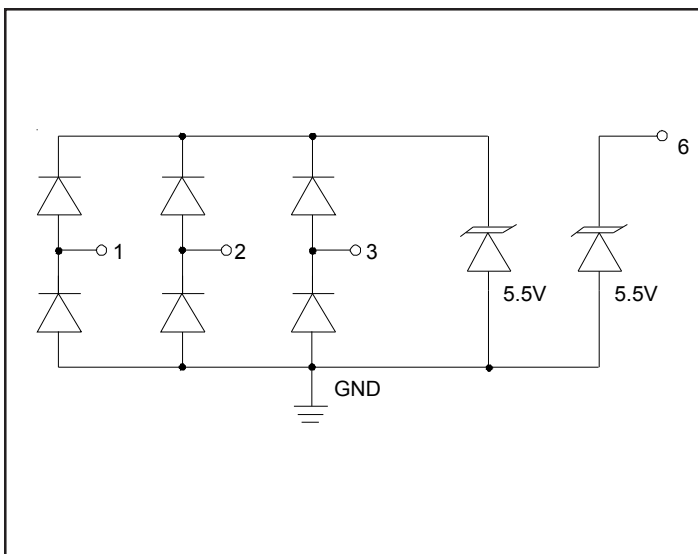

PIN Configuration

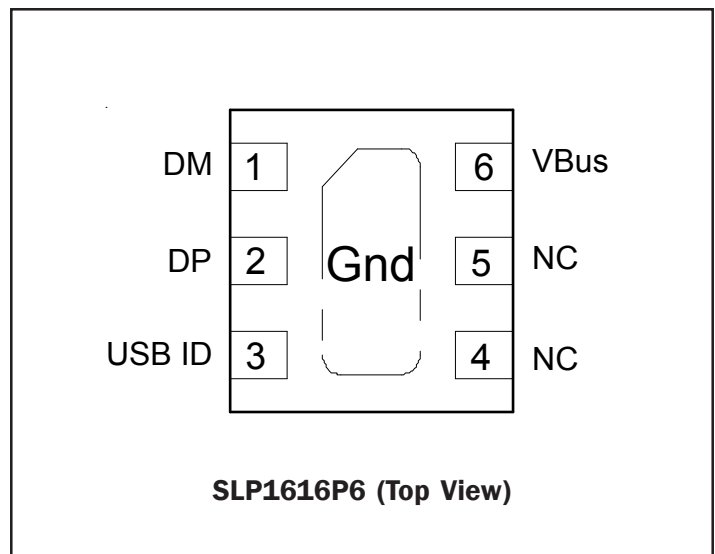

PROTECTION PRODUCTS
Absolute Maximum Rating

Rating	Symbol	Value	Units
DP, DM, USB ID (Pins 1, 2, 3)			
Peak Pulse Power (tp = 8/20μs)	P_{pk}	100	Watts
Peak Pulse Current (tp = 8/20μs)	I_{PP}	3	A
ESD per IEC 61000-4-2 (Air) ESD per IEC 61000-4-2 (Contact)	V_{ESD}	±15 ±8	kV
Operating Temperature	T_J	-55 to +125	°C
Storage Temperature	T_{STG}	-55 to +150	°C
VBus (Pin 6)			
Peak Pulse Power (tp = 8/20μs)	P_{pk}	200	Watts
Peak Pulse Current (tp = 8/20μs)	I_{PP}	16	A
ESD per IEC 61000-4-2 (Air) ESD per IEC 61000-4-2 (Contact)	V_{ESD}	±15 ±8	kV
Operating Temperature	T_J	-55 to +125	°C
Storage Temperature	T_{STG}	-55 to +150	°C

PROTECTION PRODUCTS
Electrical Characteristics (T = 25°C)

DM, DP, USB ID TVS (Pins 1, 2, 3)						
Parameter	Symbol	Conditions	Minimum	Typical	Maximum	Units
Reverse Stand-Off Voltage	V_{RWM}	Pin 1, 2, or 3 to GND			5.5	V
Reverse Breakdown Voltage	V_{BR}	$I_t = 1\text{mA}$, Pin 1, 2, or 3 to GND	6.5	8	10	V
Reverse Leakage Current	I_R	$V_{RWM} = 5.5\text{V}$, Pin 1, 2, or 3 to GND		0.100	1	μA
Forward Voltage	V_F	$I_f = 15\text{mA}$ GND to Pin 1, 2, or 3	0.6		1.2	V
Clamping Voltage	V_C	$I_{PP} = 1\text{A}$, $t_p = 8/20\mu\text{s}$ Pin 1, 2, or 3 to GND			15	V
Clamping Voltage	V_C	$I_{PP} = 3\text{A}$, $t_p = 8/20\mu\text{s}$ Pin 1, 2, or 3 to GND			30	V
Junction Capacitance	C_j	$V_R = 0\text{V}$, $f = 1\text{MHz}$, Pin 1, 2, or 3 to GND		0.8	0.95	pF
		$V_R = 0\text{V}$, $f = 1\text{MHz}$, Between I/O pins			0.5	pF

PROTECTION PRODUCTS
Electrical Characteristics (T = 25°C)

VBus TVS (Pin 6)						
Parameter	Symbol	Conditions	Minimum	Typical	Maximum	Units
Reverse Stand-Off Voltage	V_{RWM}	Pin 6 to GND			5.5	V
Reverse Breakdown Voltage	V_{BR}	$I_t = 1\text{mA}$ Pin 6 to GND	6	8	10	V
Reverse Leakage Current	I_R	$V_{RWM} = 5.5\text{V}$ Pin 6 to GND			3	μA
Forward Voltage	V_F	$I_f = 10\text{mA}$ GND to Pin 6	0.6		1.0	V
Forward Clamping Voltage	V_F	$I_{pp} = 10\text{A}$, $t_p = 8/20\mu\text{s}$ Ground to Pin 6			3	V
Clamping Voltage	V_C	$I_{pp} = 16\text{A}$, $t_p = 8/20\mu\text{s}$ Pin 6 to Ground			12.5	V
Junction Capacitance	C_j	$V_R = 0\text{V}$, $f = 1\text{MHz}$ Pin 6 to GND			275	pF

PROTECTION PRODUCTS

Typical Characteristics

Non-Repetitive Peak Pulse Power vs. Pulse Time

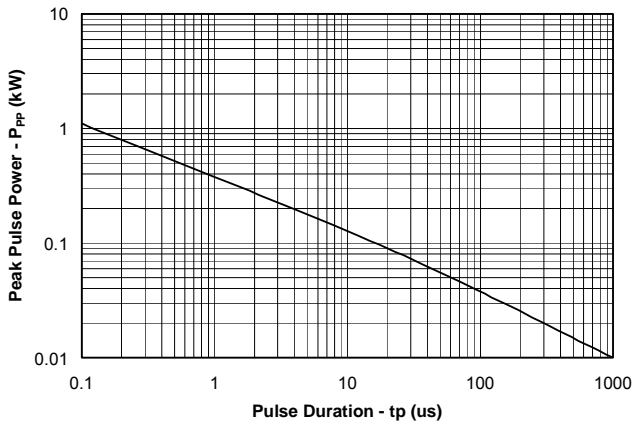

Power Derating Curve

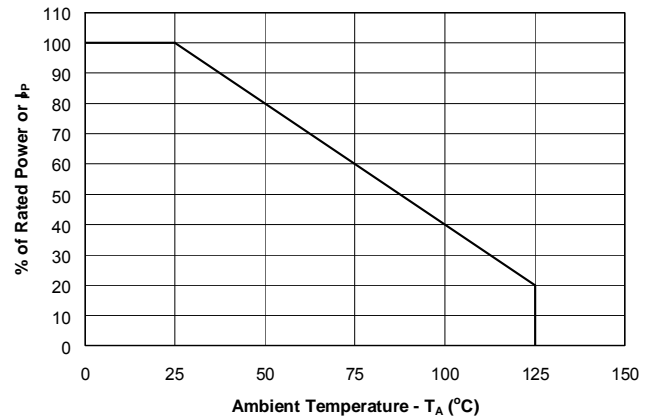

Pulse Waveform

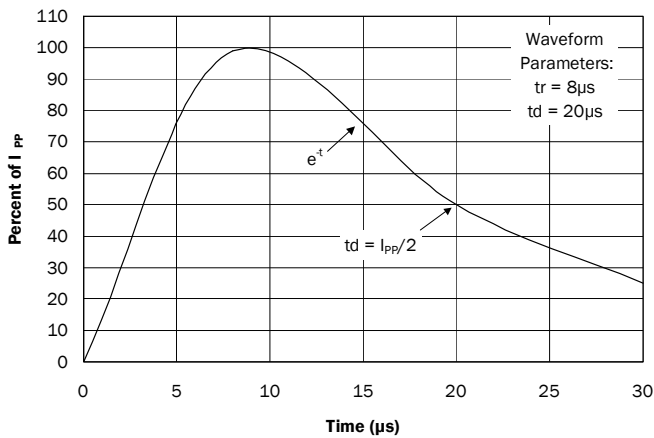

Clamping Voltage vs. Peak Pulse Current (Pin 1, 2, or 3 to GND)

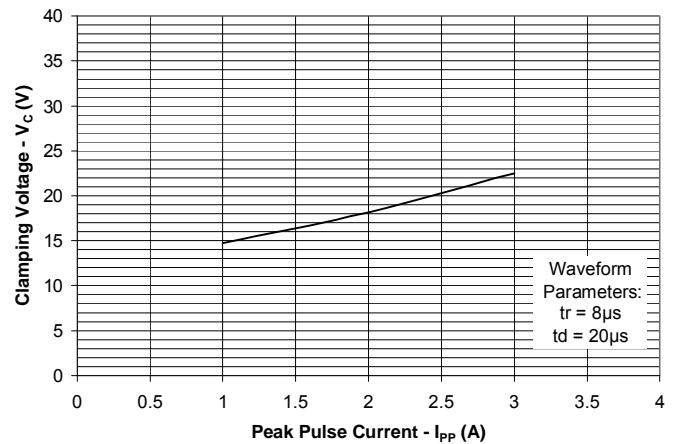

Clamping Voltage vs. Peak Pulse Current (Pin 6 to GND)

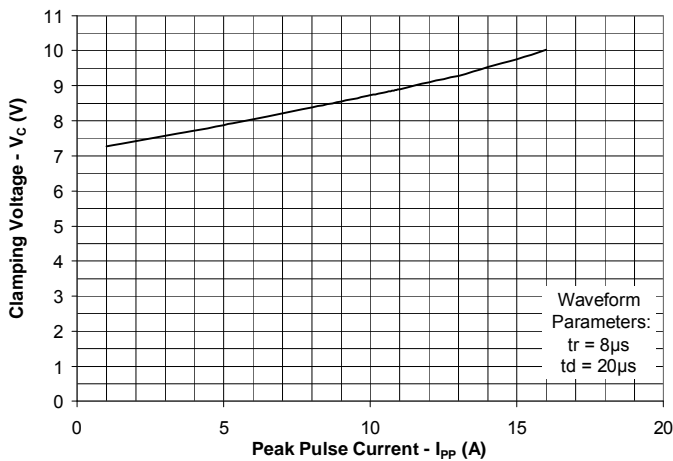

Forward Voltage vs. Peak Pulse Current (Pin GND to Pin 6)

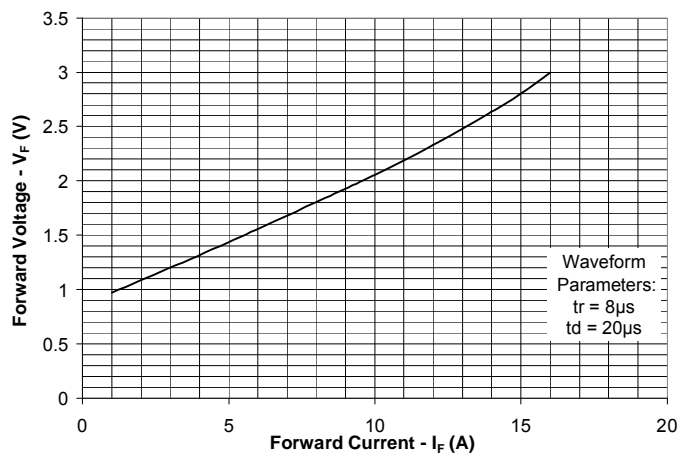

PROTECTION PRODUCTS

Typical Characteristics

Normalized Capacitance vs. Reverse Voltage
(Pin 1, 2, or 3 to Gnd)

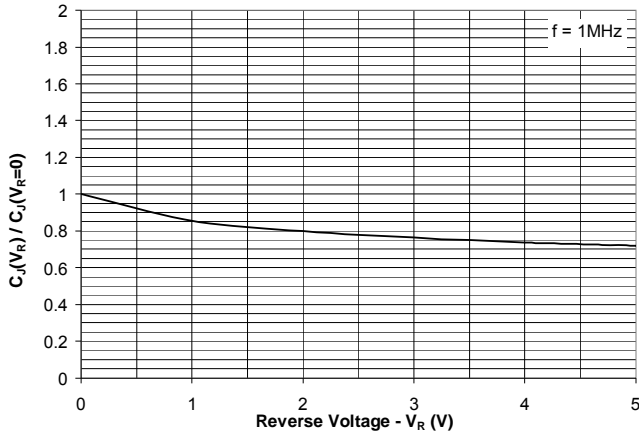

Insertion Loss S21 (Pin 1, 2, or 3 to Gnd)

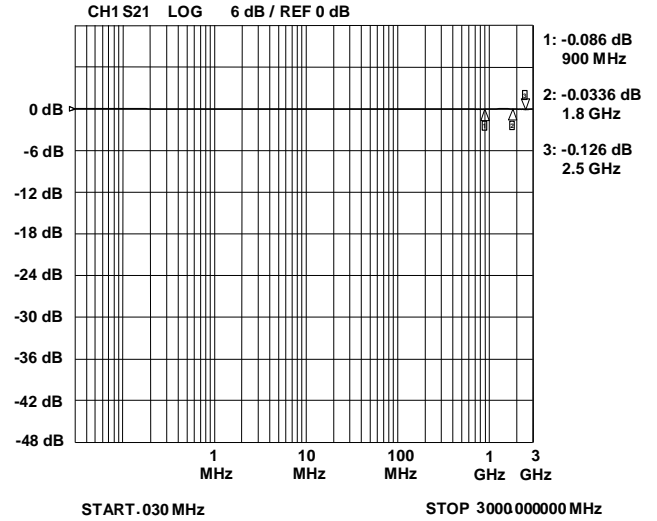

Analog Crosstalk

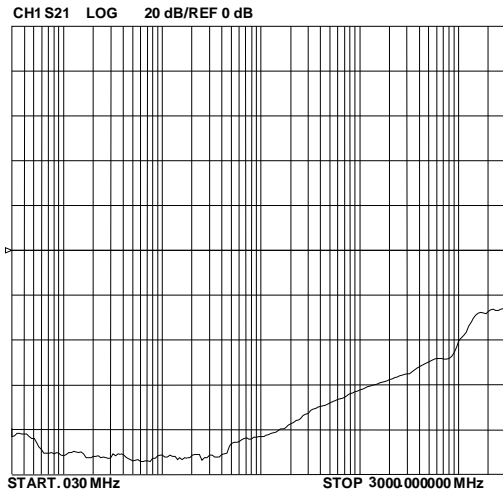

PROTECTION PRODUCTS

Applications Information

Device Connection Options for Protecting One USB Port

USB Data and ID lines are connected at pins 1, 2, and 3. These inputs are referenced to an internal 5 volt TVS protection device. When the voltage on these lines exceed 5 volts, the TVS will conduct. Pin 6 is connected to the USB voltage bus (VBus). This device will conduct when the voltage on the bus exceeds 5.5 volts. The center tab is connected to ground. The path length should also be kept as short as possible to minimize parasitic inductance. For best results, multiple micro-vias are recommended to the ground plane.

Figure 1- Pin Configuration & Circuit Diagram

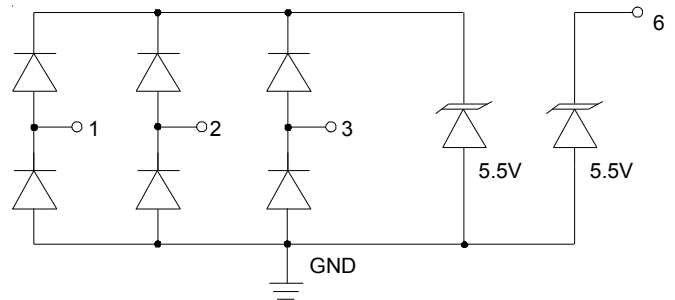

Protecting USB Interfaces

The RClamp0854P is optimized for use on systems that utilize the USB interface for battery charging. Low capacitance protection is provided for the USB data (DM, DP) and USB ID pins. The maximum capacitance on these lines is <math><1\text{pF}</math> for maximum signal integrity. All three lines are referenced to an internal 5 volt TVS device. A separate 5.5 volt TVS device is used for protection of the USB voltage bus. This allows battery charging without signal clipping. A typical example is shown in Figure 2.

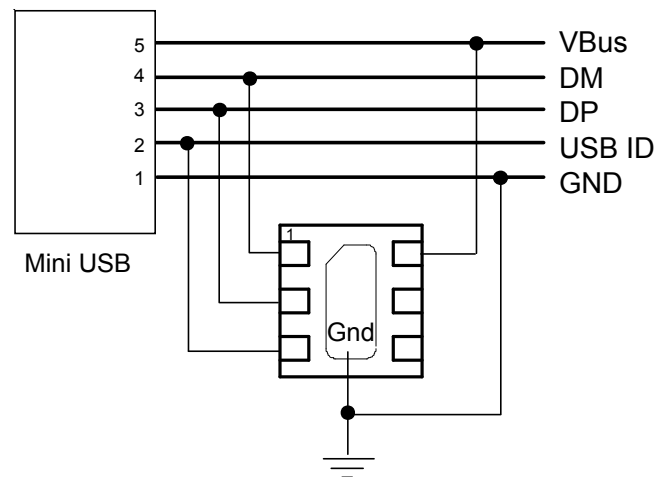
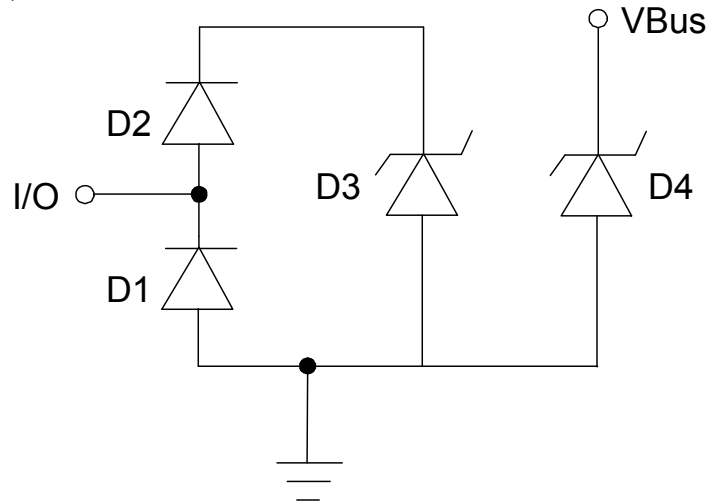

Figure 2 - USB OTG Protection

PROTECTION PRODUCTS

Applications Information - Spice Model



RClamp0854P Spice Model

RClamp0854P Spice Parameters					
Parameter	Unit	D1	D2	D3	D4
IS	Amp	1E-20	1E-20	2E-12	2.93E-12
BV	Volt	100	100	9.36	8.3
VJ	Volt	0.7	0.7	0.6	0.7
RS	Ohm	0.458	1.0	2.6	0.157
IBV	Amp	1E-3	1E-3	1E-3	1E-3
CJO	Farad	0.3E-12	0.3E-12	56E-12	212E-12
TT	sec	2.541E-9	2.541E-9	2.541E-9	2.541E-9
M	--	0.01	0.01	0.23	0.28
N	--	1.1	1.1	1.1	1.1
EG	eV	1.11	1.11	1.11	1.11

PROTECTION PRODUCTS

Outline Drawing - SLP1616P6

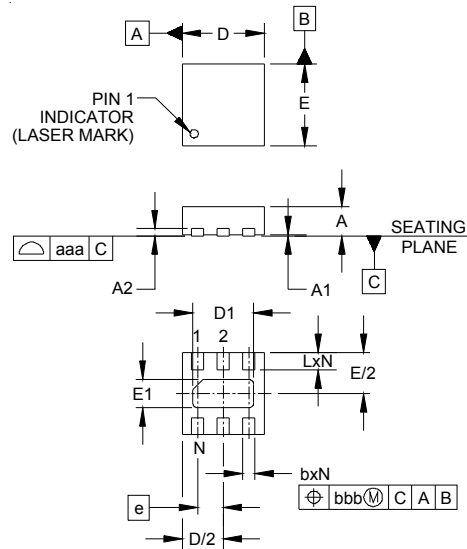

DIM	INCHES			MILLIMETERS		
	MIN	NOM	MAX	MIN	NOM	MAX
A	.020	.023	.026	0.50	0.58	0.65
A1	0.00	.001	.002	0.00	0.03	0.05
A2		(.005)			(0.13)	
b	.008	.010	.012	0.20	0.25	0.30
D	.059	.063	.067	1.50	1.60	1.70
D1	.041	.047	.051	1.05	1.20	1.30
E	.059	.063	.067	1.50	1.60	1.70
E1	.010	.016	.020	0.25	0.40	0.50
e	.020 BSC		0.50 BSC			
L	.010	.013	.016	0.25	0.33	0.40
N	6			6		
aaa	.003			0.08		
bbb	.004			0.10		

NOTES:

1. CONTROLLING DIMENSIONS ARE IN MILLIMETERS (ANGLES IN DEGREES).
2. COPLANARITY APPLIES TO THE EXPOSED PAD AS WELL AS THE TERMINALS.

Land Pattern - SLP1616P6

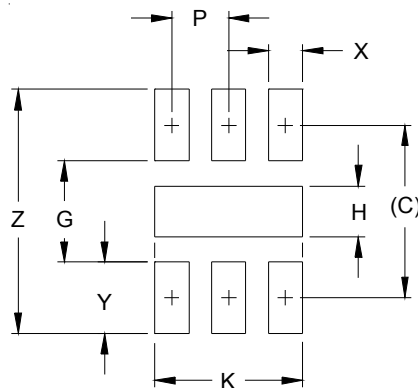

DIM	DIMENSIONS	
	INCHES	MILLIMETERS
C	.060	1.52
G	.035	0.89
H	.018	0.45
K	.051	1.30
P	.020	0.50
X	.012	0.30
Y	.025	0.63
Z	.085	2.15

NOTES:

1. CONTROLLING DIMENSIONS ARE IN MILLIMETERS (ANGLES IN DEGREES).
2. THIS LAND PATTERN IS FOR REFERENCE PURPOSES ONLY. CONSULT YOUR MANUFACTURING GROUP TO ENSURE YOUR COMPANY'S MANUFACTURING GUIDELINES ARE MET.
3. THERMAL VIAS IN THE LAND PATTERN OF THE EXPOSED PAD SHALL BE CONNECTED TO A SYSTEM GROUND PLANE. FAILURE TO DO SO MAY COMPROMISE THE THERMAL AND/OR FUNCTIONAL PERFORMANCE OF THE DEVICE.

PROTECTION PRODUCTS

Marking

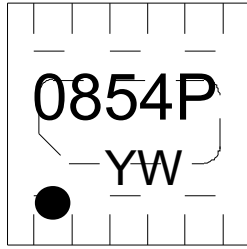

Ordering Information

Part Number	Lead Finish	Qty per Reel	Reel Size
RClamp0854P.TCT	Pb Free	3,000	7 Inch

RailClamp and RClamp are marks of Semtech Corporation

YW = Two character Date Code

Tape and Reel Specification

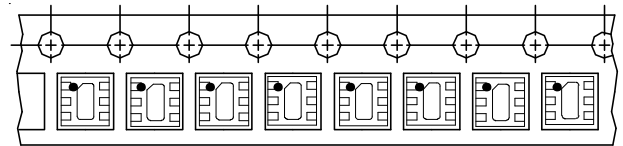
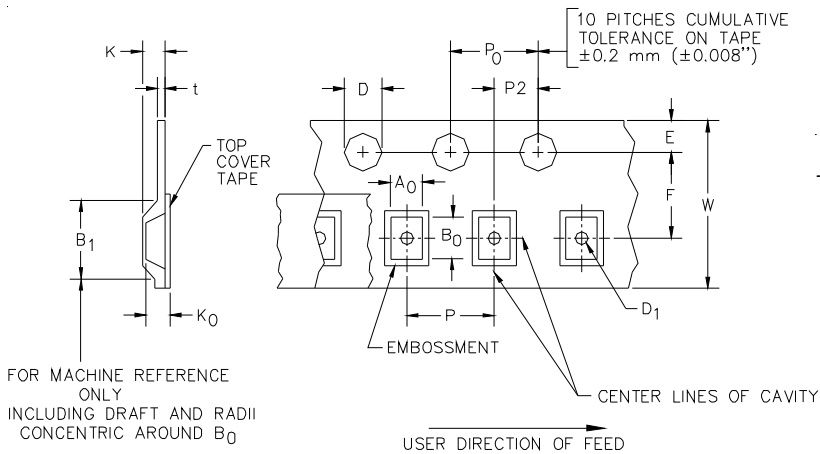

Device Orientation in Tape
Pin 1 in upper left towards sprocket holes

A0	B0	K0
1.78 +/-0.10 mm	1.78 +/-0.10 mm	0.69 +/-0.10 mm

Tape Width	B, (Max)	D	D1	E	F	K (MAX)	P	P0	P2	T(MAX)	W
8 mm	4.2 mm	1.5 + 0.1 mm - 0.0 mm)	0.5 mm ±0.05	1.750±.10 mm	3.5±0.05 mm	2.4 mm	4.0±0.1 mm	4.0±0.1 mm	2.0±0.05 mm	0.4 mm	8.0 mm + 0.3 mm - 0.1 mm

Contact Information

Semtech Corporation
 Protection Products Division
 200 Flynn Rd., Camarillo, CA 93012
 Phone: (805)498-2111 FAX (805)498-3804

X-ON Electronics

Largest Supplier of Electrical and Electronic Components

Click to view similar products for [ESD Suppressors / TVS Diodes](#) category:

Click to view products by [Semtech](#) manufacturer:

Other Similar products are found below :

[60KS200C](#) [D12V0H1U2WS-7](#) [D18V0L1B2LP-7B](#) [82356050220](#) [D5V0M5U6V-7](#) [NTE4902](#) [P4KE27CA](#) [P6KE11CA](#) [P6KE39CA-TP](#)
[P6KE8.2A](#) [SA110CA](#) [SA60CA](#) [SA64CA](#) [SMBJ12CATR](#) [SMBJ8.0A](#) [SMLJ30CA-TP](#) [ESD101-B1-02ELS E6327](#) [ESD112-B1-02EL E6327](#)
[ESD119B1W01005E6327XTSA1](#) [ESD5V0L1B02VH6327XTSA1](#) [ESD7451N2T5G](#) [19180-510](#) [CPDT-5V0USP-HF](#) [3.0SMCJ33CA-F](#)
[3.0SMCJ36A-F](#) [HSPC16701B02TP](#) [D3V3Q1B2DLP3-7](#) [D55V0M1B2WS-7](#) [DESD5V0U1BL-7B](#) [DRTR5V0U4SL-7](#) [SCM1293A-04SO](#)
[ESD200-B1-CSP0201 E6327](#) [ESD203-B1-02EL E6327](#) [SM12-7](#) [SMF8.0A-TP](#) [SMLJ45CA-TP](#) [CEN955 W/DATA](#) [82350120560](#)
[82356240030](#) [VESD12A1A-HD1-GS08](#) [CPDUR5V0R-HF](#) [CPDUR24V-HF](#) [CPDQC5V0U-HF](#) [CPDQC5V0USP-HF](#) [CPDQC5V0-HF](#)
[D1213A-01LP4-7B](#) [D1213A-02WL-7](#) [ESDLIN1524BJ-HQ](#) [5KP100A](#) [5KP15A](#)