

PROTECTION PRODUCTS - RailClamp®
Description

RailClamp® TVS diode arrays are specifically designed to protect sensitive components which are connected to high-speed data and transmission lines from over-voltage caused by **ESD** (electrostatic discharge), **CDE** (Cable Discharge Events), and **EFT** (electrical fast transients). The RClamp®7002M has been optimized for use on the next generation of ADSL interfaces. Their high surge capability makes them particularly useful in systems that utilize gas tubes as the primary protection component.

This device integrates surge rated, low capacitance steering diodes in a small MSOP-10L package. Each protection diode features a large area junction to minimize clamping voltage and increase reliability during high current surges. It has a maximum capacitance of only 10pF and may be used to protect two high-speed lines without sacrificing signal integrity. The RClamp7002M may be used on systems operating from 3.3 to 70 volts. This means that they may be used in applications that use the Central Office battery as the main supply.

The RClamp7002M is also designed for easy board layout by allowing the signal traces to run straight through the device. The high surge capability, ease of layout coupled with the low capacitance and clamping voltage of the RClamp7002M makes it the superior choice for protecting two high speed lines against high energy telecommunication surges.

Features

- ◆ 1000 Watts peak pulse power (**8/20µs**)
- ◆ Protection for high-speed data lines to
IEC 61000-4-2 (ESD) ±15kV (air), ±8kV (contact)
IEC 61000-4-4 (EFT) 40A (5/50ns)
IEC 61000-4-5 (Lightning) 1kV, 24A (1.2/50µs)
- ◆ Low clamping voltage: **10V at Ipp = 40A (8/20µs)**
- ◆ Array of surge rated suppression diodes
- ◆ Protects two high speed lines
- ◆ Low capacitance: **10pF** (I/O to Ground)
- ◆ Operating voltage range: 3.3 - 70V
- ◆ Small package saves board space
- ◆ Solid-state silicon-avalanche technology

Mechanical Characteristics

- ◆ JEDEC MSOP-10L package
- ◆ Molding compound flammability rating: UL 94V-0
- ◆ Marking: Marking code and date code
- ◆ Packaging: Tape and Reel
- ◆ Lead Finish: Matte tin
- ◆ Pb-Free, Halogen Free, RoHS/WEEE Compliant

Applications

- ◆ ADSL Lines
- ◆ Central Office Equipment
- ◆ T1/E1 secondary IC Side Protection
- ◆ Small Office Home Office (SOHO) Applications
- ◆ WAN/LAN Equipment
- ◆ ISDN S/T Interface
- ◆ ATM Interfaces

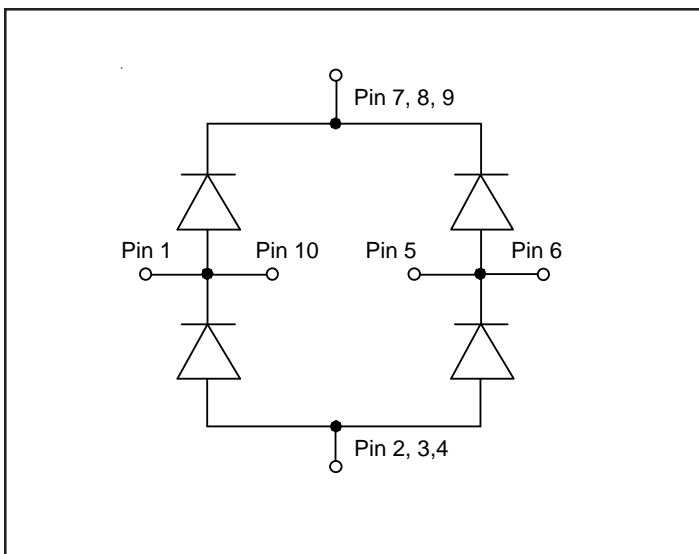
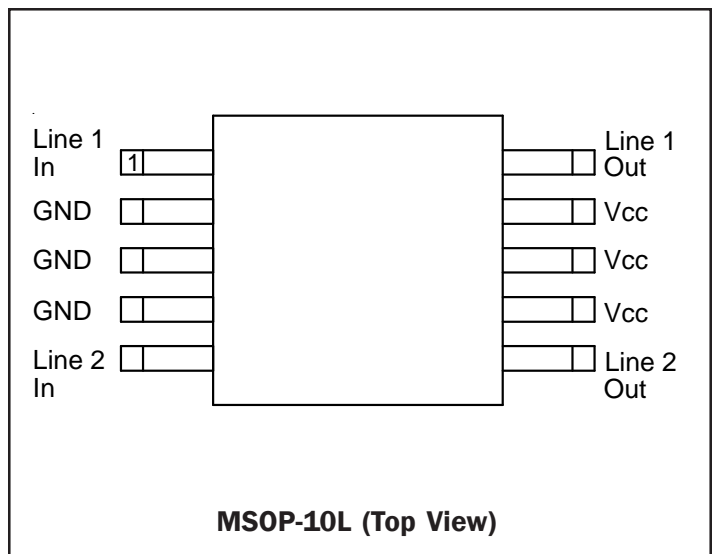
Circuit Diagram

PIN Configuration

PROTECTION PRODUCTS
Absolute Maximum Rating

| Rating | Symbol | Value | Units |
|--|-----------|-------------|-------|
| Peak Pulse Power ($t_p = 8/20\mu s$) | P_{PP} | 1000 | W |
| Peak Pulse Current ($t_p = 8/20\mu s$) | I_{PP} | 70 | A |
| ESD per IEC 61000-4-2 (Air) ESD per IEC 61000-4-2 (Contact) | V_{ESD} | 15 8 | kV |
| Operating Temperature | T_J | -55 to +125 | °C |
| Storage Temperature | T_{STG} | -55 to +150 | °C |

Electrical Characteristics (T=25°C)

| Parameter | Symbol | Conditions | Minimum | Typical | Maximum | Units |
|---------------------------|-----------|--|---------|---------|---------|---------|
| Reverse Stand-Off Voltage | V_{RWM} | | | | 70 | V |
| Reverse Breakdown Voltage | V_{BR} | $I_t = 50\mu A$ | 85 | | | V |
| Reverse Leakage Current | I_R | $V_{RWM} = 70V, T=25^\circ C$ | | | 5 | μA |
| Forward Voltage | V_f | $I_f = 15mA$ | | | 1.2 | V |
| Clamping Voltage | V_C | $I_{PP} = 1A, t_p = 8/20\mu s$ Any I/O pin to Ground | | | 1.5 | V |
| Clamping Voltage | V_C | $I_{PP} = 40A, t_p = 8/20\mu s$ Any I/O pin to Ground | | | 10 | V |
| Clamping Voltage | V_C | $I_{PP} = 70A, t_p = 8/20\mu s$ Any I/O pin to Ground | | | 14.3 | V |
| Junction Capacitance | C_J | $V_R = 0V, f = 1MHz$ Any I/O pin to Ground | | | 10 | pF |
| | | $V_R = 0V, f = 1MHz$ Between I/O pins | | 3 | | pF |

PROTECTION PRODUCTS

Typical Characteristics

Non-Repetitive Peak Pulse Power vs. Pulse Time

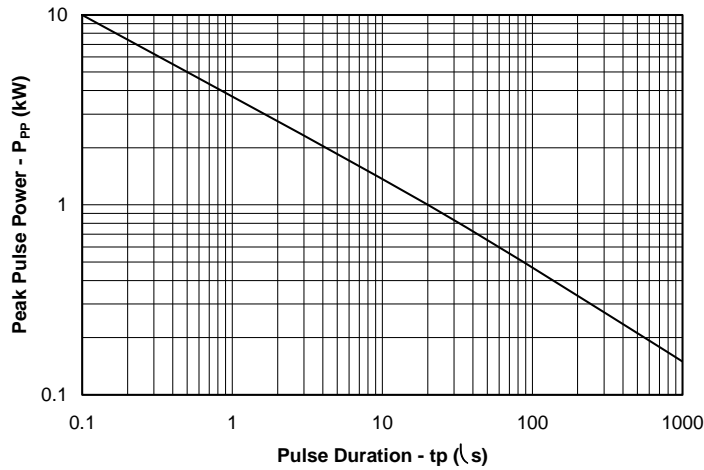

Power Derating Curve

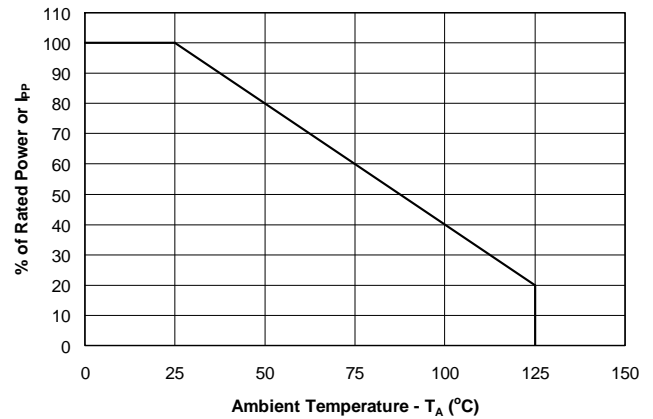

Pulse Waveform

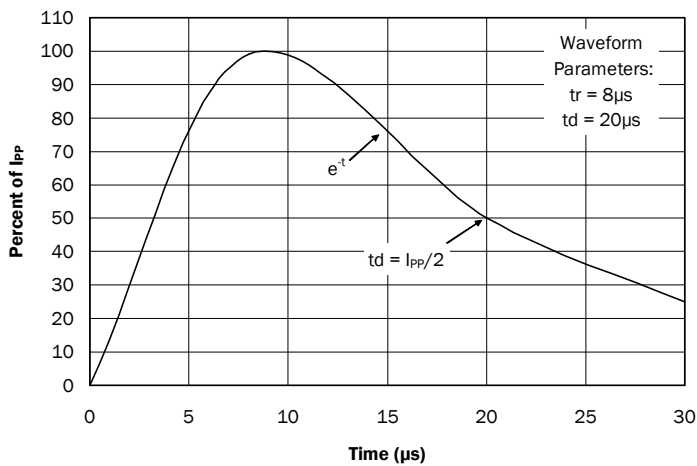

Capacitance vs. Reverse Voltage

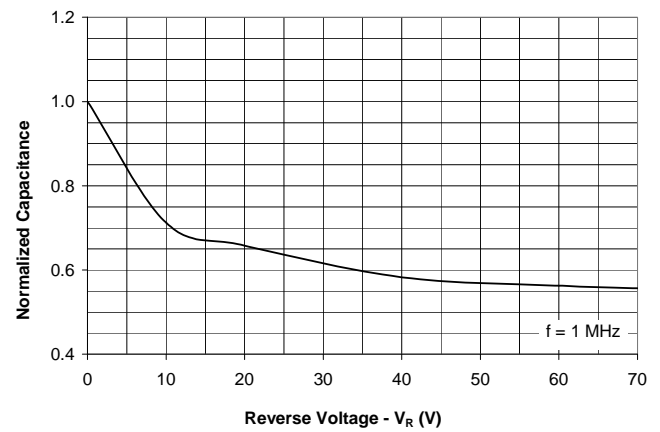

Forward Voltage vs. Forward Current

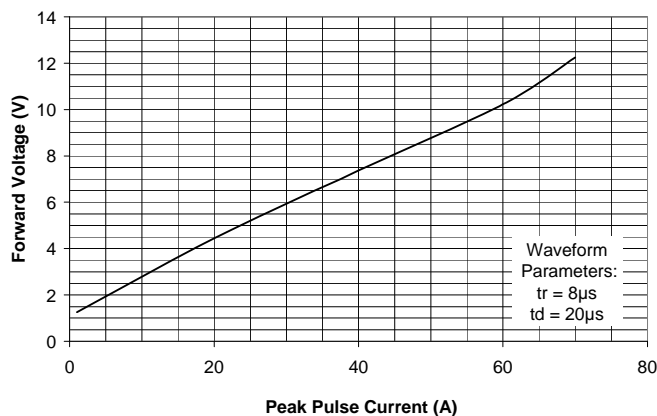

Insertion Loss S21

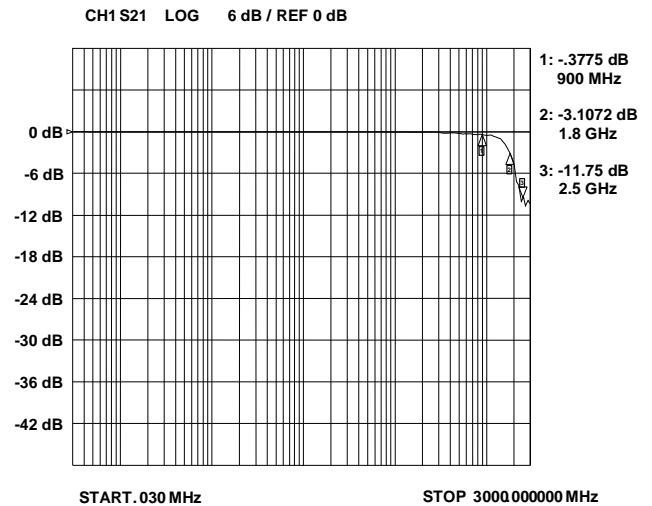

PROTECTION PRODUCTS

Applications Information

Device Connection Options for Protection of Two High-Speed Data Lines

This device is designed to protect two data lines from transient over-voltages by clamping them to a fixed reference. When the voltage on the protected line exceeds the reference voltage (plus diode V_f) the steering diodes are forward biased, conducting the transient current away from the sensitive circuitry. Data line inputs are connected at pins 1 and 5. The outputs are connected at pins 10 and 6 respectively. The negative reference is connected at pins 2, 3, and 4. These pins should be connected directly to a ground plane on the board for best results. The path length is kept as short as possible to minimize parasitic inductance. The positive reference is connected at pins 7, 8, and 9. The options for connecting the positive reference are as follows:

1. To protect data lines and the power line, connect pins 7, 8 and 9 directly to the positive supply rail (V_{CC}). In this configuration the data lines are referenced to the supply voltage. An external TVS diode may be added between the supply rail and ground in order to prevent over-voltage on the supply rail.
2. In applications where no positive supply reference is available, or complete supply isolation is desired, an external TVS diode may be used as the reference. The steering diodes will begin to conduct when the voltage on the protected line exceeds the working voltage of the TVS (plus one diode drop).

Schematic

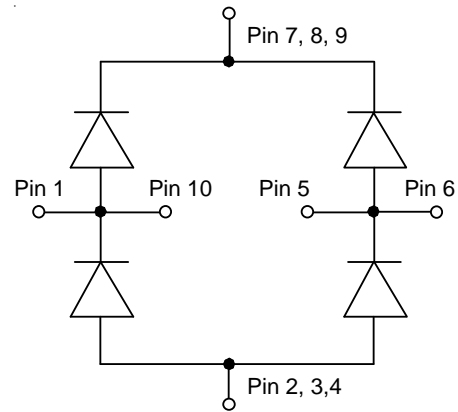

Pin Configuration

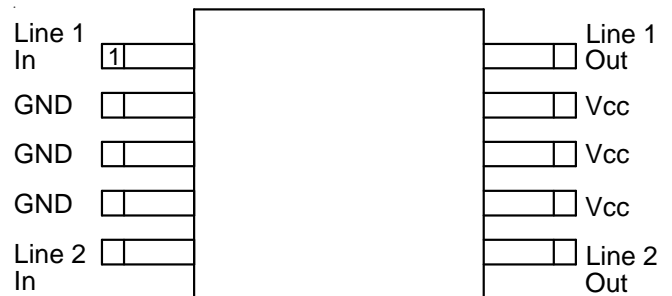

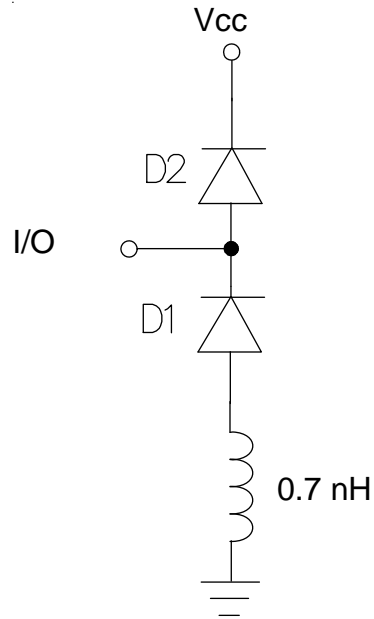
PROTECTION PRODUCTS
Applications Information - Spice Model

RClamp7002M Spice Model

| Table 1 - RClamp7002M Spice Parameters | | | |
|---|-------------|------------------|------------------|
| Parameter | Unit | D1 (LCRD) | D2 (LCRD) |
| IS | Amp | 1.0E-20 | 1.0E-20 |
| BV | Volt | 200 | 200 |
| VJ | Volt | 0.53 | 0.53 |
| RS | Ohm | 0.037 | 0.14 |
| IBV | Amp | 1E-3 | 1E-3 |
| CJO | Farad | 3.5E-12 | 3.5E-12 |
| TT | sec | 2.541E-9 | 2.541E-9 |
| M | -- | 0.142 | 0.142 |
| N | -- | 1.1 | 1.1 |
| EG | eV | 1.11 | 1.11 |

PROTECTION PRODUCTS

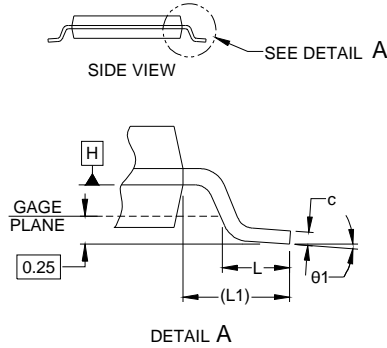
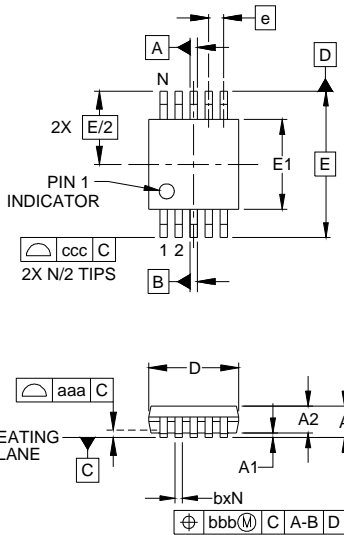
Outline Drawing - MSOP 10L



| DIM | INCHES | | | MILLIMETERS | | |
|--------|----------|------|------|-------------|------|------|
| | MIN | NOM | MAX | MIN | NOM | MAX |
| A | - | - | .043 | - | - | 1.10 |
| A1 | .000 | - | .006 | 0.00 | - | 0.15 |
| A2 | .030 | - | .037 | 0.75 | - | 0.95 |
| b | .007 | - | .011 | 0.17 | - | 0.27 |
| c | .003 | - | .009 | 0.08 | - | 0.23 |
| D | .114 | .118 | .122 | 2.90 | 3.00 | 3.10 |
| E1 | .114 | .118 | .122 | 2.90 | 3.00 | 3.10 |
| E | .193 BSC | | | 4.90 BSC | | |
| e | .020 BSC | | | 0.50 BSC | | |
| L | .016 | .024 | .032 | 0.40 | 0.60 | 0.80 |
| L1 | (.037) | | | (.95) | | |
| N | 10 | | | 10 | | |
| theta1 | 0° | - | 8° | 0° | - | 8° |
| aaa | .004 | | | 0.10 | | |
| bbb | .003 | | | 0.08 | | |
| ccc | .010 | | | 0.25 | | |

NOTES:

1. CONTROLLING DIMENSIONS ARE IN MILLIMETERS (ANGLES IN DEGREES).
2. DATUMS **-A-** AND **-B-** TO BE DETERMINED AT DATUM PLANE **-H-**
3. DIMENSIONS "E1" AND "D" DO NOT INCLUDE MOLD FLASH, PROTRUSIONS OR GATE BURRS.
4. REFERENCE JEDEC STD MO-187, VARIATION BA.

Land Pattern - MSOP 10L

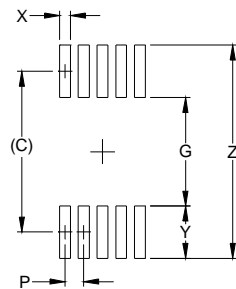

| DIMENSIONS | | |
|------------|--------|-------------|
| DIM | INCHES | MILLIMETERS |
| C | (.161) | (4.10) |
| G | .098 | 2.50 |
| P | .020 | 0.50 |
| X | .011 | 0.30 |
| Y | .063 | 1.60 |
| Z | .224 | 5.70 |

NOTES:

1. THIS LAND PATTERN IS FOR REFERENCE PURPOSES ONLY. CONSULT YOUR MANUFACTURING GROUP TO ENSURE YOUR COMPANY'S MANUFACTURING GUIDELINES ARE MET.

PROTECTION PRODUCTS

Marking Codes

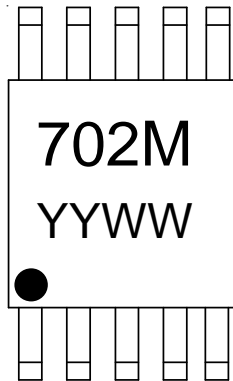

YYWW = Date Code

Tape and Reel Specification

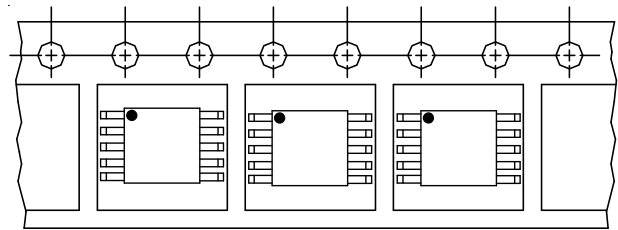
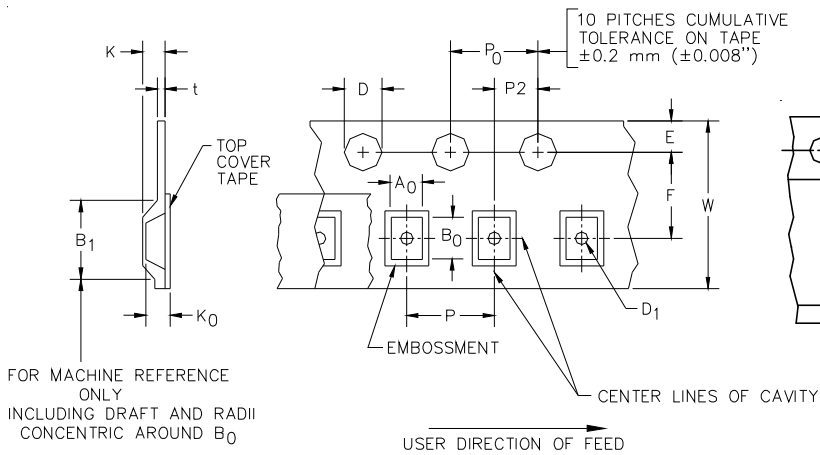

Device Orientation in Tape

| A0 | B0 | K0 |
|-----------------|-----------------|-----------------|
| 5.30 +/-0.20 mm | 3.40 +/-0.20 mm | 1.40 +/-0.10 mm |

| Tape Width | B, (Max) | D | D1 | E | F | K (MAX) | P | P0 | P2 | T(MAX) | W |
|------------|----------|----------------------------|-----------------|----------------|----------------|---------|---------------|---------------|----------------|--------|---------------------|
| 12 mm | 8.2 mm | 1.5 + 0.1 mm - 0.0 mm) | 0.5 mm ±0.05 | 1.750±10 mm | 5.5±0.05 mm | 4.5 mm | 8.0±0.1 mm | 4.0±0.1 mm | 2.0±0.05 mm | 0.4 mm | 12.0 mm ± 0.3 mm |

Contact Information

Semtech Corporation
 Protection Products Division
 200 Flynn Road, Camarillo, CA 93012
 Phone: (805)498-2111 FAX (805)498-3804

X-ON Electronics

Largest Supplier of Electrical and Electronic Components

Click to view similar products for [ESD Suppressors / TVS Diodes](#) category:

Click to view products by [Semtech](#) manufacturer:

Other Similar products are found below :

[60KS200C](#) [D12V0H1U2WS-7](#) [D18V0L1B2LP-7B](#) [82356050220](#) [D5V0M5U6V-7](#) [NTE4902](#) [P4KE27CA](#) [P6KE11CA](#) [P6KE39CA-TP](#)
[P6KE8.2A](#) [SA110CA](#) [SA60CA](#) [SA64CA](#) [SMBJ12CATR](#) [SMBJ8.0A](#) [SMLJ30CA-TP](#) [ESD101-B1-02ELS E6327](#) [ESD112-B1-02EL E6327](#)
[ESD119B1W01005E6327XTSA1](#) [ESD5V0L1B02VH6327XTSA1](#) [ESD7451N2T5G](#) [19180-510](#) [CPDT-5V0USP-HF](#) [3.0SMCJ33CA-F](#)
[3.0SMCJ36A-F](#) [HSPC16701B02TP](#) [D3V3Q1B2DLP3-7](#) [D55V0M1B2WS-7](#) [DESD5V0U1BL-7B](#) [DRTR5V0U4SL-7](#) [SCM1293A-04SO](#)
[ESD200-B1-CSP0201 E6327](#) [ESD203-B1-02EL E6327](#) [SM12-7](#) [SMF8.0A-TP](#) [SMLJ45CA-TP](#) [CEN955 W/DATA](#) [82350120560](#)
[82356240030](#) [VESD12A1A-HD1-GS08](#) [CPDUR5V0R-HF](#) [CPDUR24V-HF](#) [CPDQC5V0U-HF](#) [CPDQC5V0USP-HF](#) [CPDQC5V0-HF](#)
[D1213A-01LP4-7B](#) [D1213A-02WL-7](#) [ESDLIN1524BJ-HQ](#) [5KP100A](#) [5KP15A](#)