

POWER MANAGEMENT

Description

The SC1202 series of high performance positive voltage regulators are designed for use in applications requiring low dropout performance at full rated current. Additionally, the SC1202 series provides excellent regulation over variations due to line, load and temperature.

Outstanding features include low dropout performance at rated current, fast transient response, internal current limiting and thermal shutdown protection of the output device. The SC1202 series are three terminal regulators available in the surface mount SOT-223 package.

Features

- ◆ Low dropout performance, 1.3V max.
- ◆ Full current rating over line and temperature
- ◆ Fast transient response
- ◆ $\pm 2\%$ total output regulation over line, load and temperature
- ◆ Adjust pin current max. 90 μ A over temperature
- ◆ Adjustable or fixed output voltages
- ◆ Line regulation 0.2% max.
- ◆ Load regulation 0.4% max.
- ◆ SOT-223 package. Fully WEEE and RoHS compliant

Applications

- ◆ Low voltage microcontrollers
- ◆ Microprocessor I/O supplies
- ◆ 5V to 3.3V conversion for memory, ASIC, custom circuits, etc.

Typical Application Circuits

Fixed Voltage Regulator

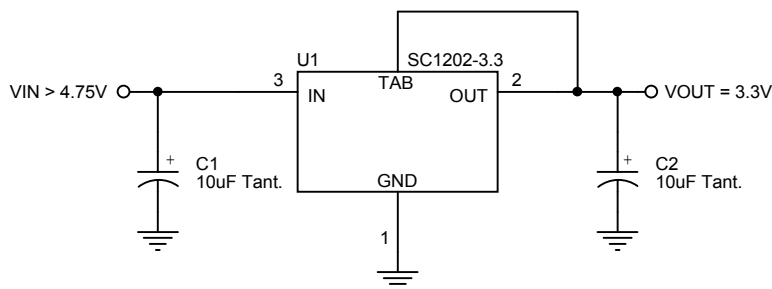

Adjustable Voltage Regulator

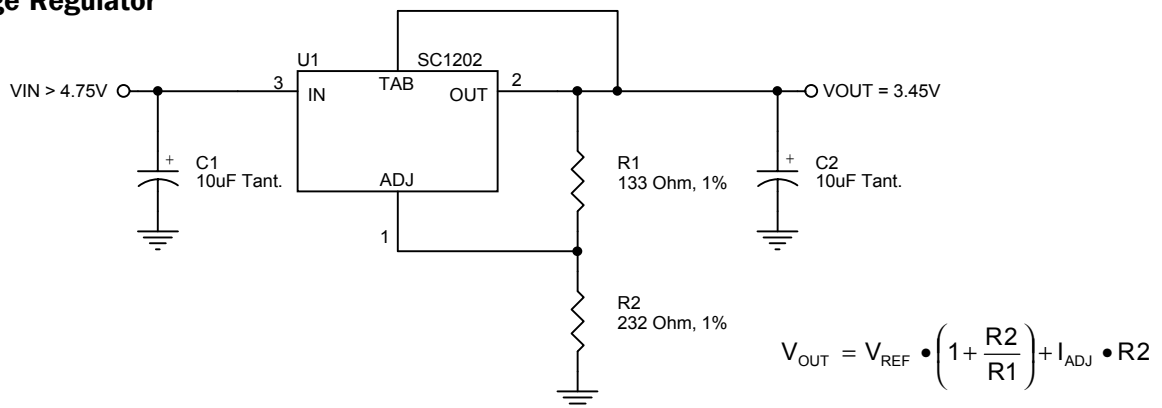

Notes:

- (1) C1 needed if device is far from filter capacitors
- (2) C2 minimum value required for stability

POWER MANAGEMENT
Absolute Maximum Ratings

Exceeding the specifications below may result in permanent damage to the device, or device malfunction. Operation outside of the parameters specified in the Electrical Characteristics section is not implied.

Parameter	Symbol	Maximum	Units
Input Voltage	V_{IN}	7	V
Power Dissipation	P_D	Internally Limited	W
Thermal Resistance, Junction to Case	θ_{JC}	15	°C/W
Thermal Resistance, Junction to Ambient	θ_{JA}	156	°C/W
Operating Ambient Temperature Range	T_A	0 to 70	°C
Operating Junction Temperature Range	T_J	0 to 125	°C
Storage Temperature Range	T_{STG}	-65 to 150	°C
Lead Temperature (Soldering) 10 seconds	T_{LEAD}	300	°C
ESD Rating (Human Body Model)	ESD	2	kV

Electrical Characteristics

Unless otherwise specified, Adj. $V_{IN} = 2.65$ to $7V$ and Adj. $I_o = 10mA$ to $600mA$;
Fixed $V_{IN} = 4.75$ to $7V$ and Fixed $I_o = 0mA$ to $600mA$

Parameter	Symbol	V_{IN}	I_o	$T_J^{(4)}$	Min	Typ	Max	Units
Output Voltage ⁽¹⁾	V_O	5V	0mA	25°C	3.265	3.300	3.335	V
Fixed Voltage Option					O.T.	3.230	3.300	
Reference Voltage ⁽¹⁾	V_{REF}	5V	10mA	25°C	1.238	1.250	1.262	V
Adj. Voltage Version					O.T.	1.225	1.250	
Line Regulation ⁽¹⁾	$REG_{(LINE)}$		10mA	O.T.		0.035	0.2	%
Load Regulation ⁽¹⁾	$REG_{(LOAD)}$	5V		O.T.		0.2	0.4	%
Dropout Voltage $\Delta V_{OUT}, \Delta V_{REF} = 1\%$	V_D			O.T.		1.2	1.3	V
Current Limit	I_{CL}			O.T.	600			mA
Quiescent Current Fixed Voltage Version	I_Q	5V		O.T.		10	13	mA
Temperature Coefficient	T_C			O.T.		0.005		%/°C
Adjust Pin Current	I_{ADJ}			O.T.		55	90	μA
Adjust Pin Current Change	ΔI_{ADJ}			O.T.		0.2	5.0	μA

POWER MANAGEMENT
Electrical Characteristics (Cont.)

Unless otherwise specified, Adj. V_{IN} = 2.65 to 7V and Adj. I_o = 10mA to 600mA;
 Fixed V_{IN} = 4.75 to 7V and Fixed I_o = 0mA to 600mA

Parameter	Symbol	V_{IN}	I_o	$T_J^{(4)}$	Min	Typ	Max	Units
Temperature Stability	T_S			O.T.		0.5		%
Minimum Load Current Adj. Voltage Version	$I_{O(MIN)}$	5V		O.T.		5	10	mA
RMS Output Noise ⁽²⁾	V_N			25°C		0.003		% V_o
Ripple Rejection Ratio ⁽³⁾	R_A	5V	600mA	O.T.	60	72		dB

NOTES:

- (1) Low duty cycle pulse testing with Kelvin connections required.
- (2) Bandwidth of 10 Hz to 10 kHz.
- (3) 120 Hz input ripple, (C_{ADJ} for ADJ = 25 μ F).
- (4) Over Temp. (O.T.) = over specified operating junction temperature range.

POWER MANAGEMENT

Pin Configuration

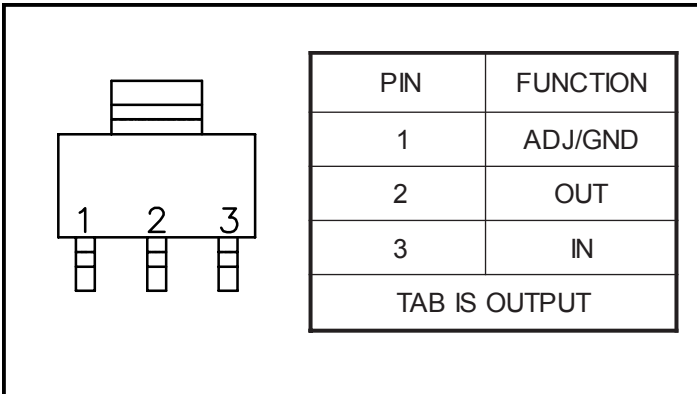

Ordering Information

Device ⁽¹⁾⁽²⁾	V _{OUT} (V)	Package
SC1202CST-X.X.TR	1.3 to 5.7	SOT-223
SC1202CST3.3TRT ⁽³⁾		
SC1202CSX.XTRT ⁽³⁾		

Notes:

- (1) Where X.X denotes voltage options. Available voltages are: 3.3V. Leave blank for adjustable version (see V_{OUT}). Contact factory for additional voltage options.
- (2) Only available in tape and reel packaging. A reel contains 2500 devices.
- (3) This product is fully WEEE and RoHS compliant.

Pin Descriptions

Pin Number	Pin Name	Pin Function
1	ADJ GND	This pin is the negative side of the reference voltage for the device. Transient response can be improved by adding a small bypass capacitor from the adjust pin to ground. This pin is the bottom end of the internal resistor feedback chain for fixed output voltage parts, and should be connected to ground.
2	OUT	This is the power output of the device, and is electrically connected to the TAB.
3	IN	This is the input supply pin for the device.

Block Diagram

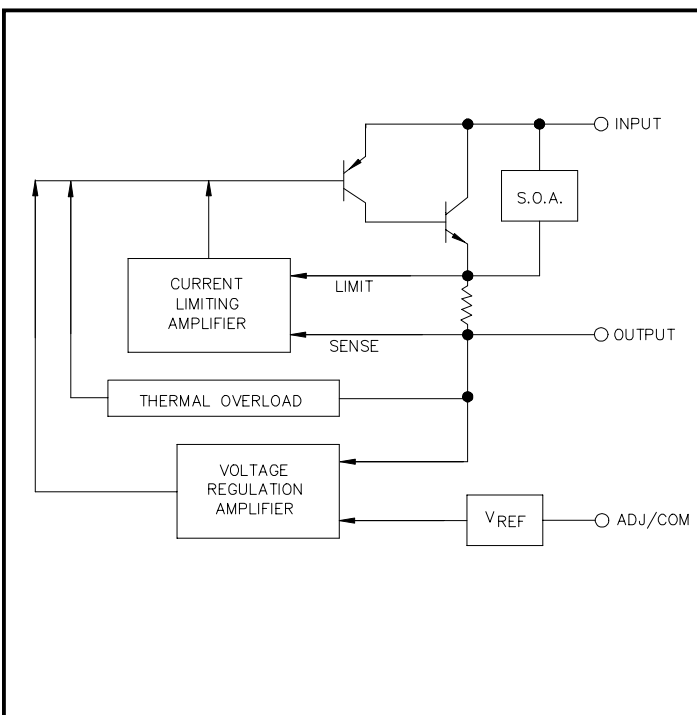

Marking Information

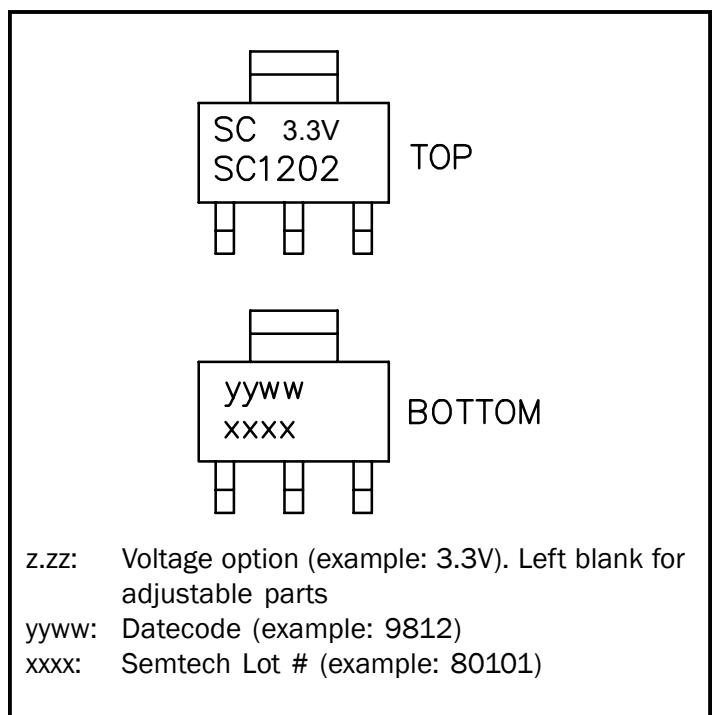

POWER MANAGEMENT

Outline Drawing - SOT-223

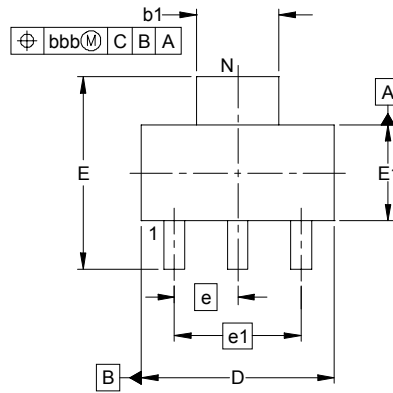

DIM	INCHES			MILLIMETERS		
	MIN	NOM	MAX	MIN	NOM	MAX
A	-	-	.070	-	-	1.80
A1	.000	-	.004	0.02	-	0.10
A2	.059	.063	.067	1.50	1.60	1.70
b	.025	-	.033	0.65	-	0.85
b1	.114	-	.124	2.90	-	3.15
c	.009	-	.014	0.23	-	0.35
D	.248	.256	.264	6.30	6.50	6.70
E	.264	.276	.287	6.70	7.00	7.30
E1	.130	.138	.146	3.30	3.50	3.70
e	.090 BSC			2.30 BSC		
e1	.181 BSC			4.60 BSC		
L	.030	-	-	0.75	-	-
N	4			4		
θ1	0°	-	10°	0°	-	10°
aaa	.003			0.08		
bbb	.004			0.10		

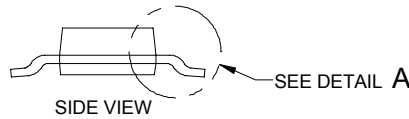
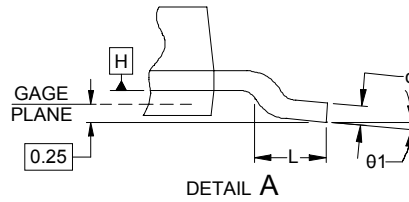
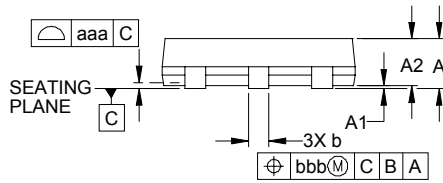

NOTES:

1. CONTROLLING DIMENSIONS ARE IN MILLIMETERS (ANGLES IN DEGREES).
2. DATUMS [-A-] AND [-B-] TO BE DETERMINED AT DATUM PLANE [-H-]
3. DIMENSIONS "E1" AND "D" DO NOT INCLUDE MOLD FLASH, PROTRUSIONS OR GATE BURRS.
4. REFERENCE JEDEC STD TO-261, VARIATION AA.

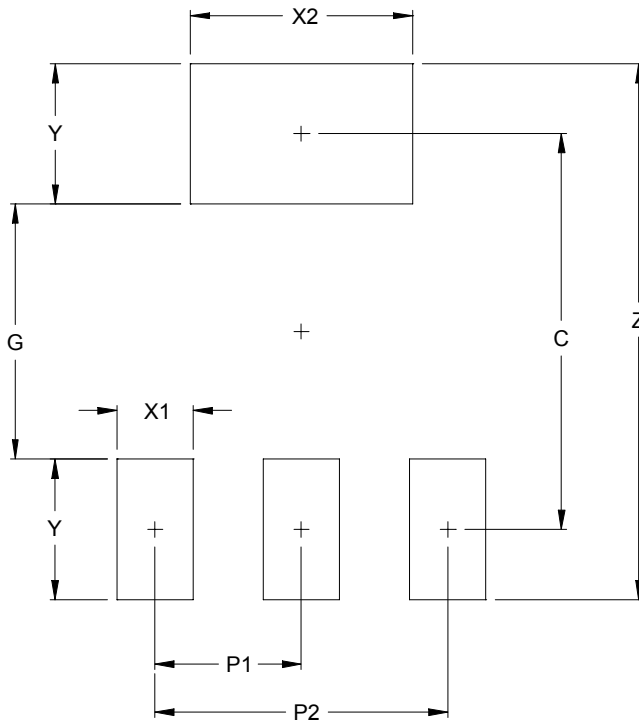
POWER MANAGEMENT
Land Pattern - SOT-223

DIMENSIONS		
DIM	INCHES	MILLIMETERS
C	(.244)	(6.20)
G	.157	4.00
P1	.091	2.30
P2	.181	4.60
X1	.047	1.20
X2	.138	3.50
Y	.087	2.20
Z	.331	8.40

NOTES:

1. THIS LAND PATTERN IS FOR REFERENCE PURPOSES ONLY
CONSULT YOUR MANUFACTURING GROUP TO ENSURE YOUR
COMPANY'S MANUFACTURING GUIDELINES ARE MET.
2. REFERENCE IPC-SM-782A.

Contact Information

Semtech Corporation
 Power Management Products Division
 200 Flynn Road, Camarillo, CA 93012
 Phone: (805)498-2111 FAX (805)498-3804

X-ON Electronics

Largest Supplier of Electrical and Electronic Components

Click to view similar products for [LDO Voltage Regulators](#) category:

Click to view products by [Semtech](#) manufacturer:

Other Similar products are found below :

[M38D29FFHP#U1](#) [702103A](#) [717726C](#) [742457H](#) [MP20051DN-LF-Z](#) [R5F111PGGFB#30](#) [AP7363-SP-13](#) [NCP103AMX285TCG](#)
[NCV8664CST33T3G](#) [NCV8752AMX28TCG](#) [L9454](#) [AP7362-HA-7](#) [LX13043CLD](#) [TCR3DF185,LM\(CT](#) [TCR3DF24,LM\(CT](#)
[TCR3DF285,LM\(CT](#) [TCR3DF31,LM\(CT](#) [TCR3DF45,LM\(CT](#) [TLF4949EJ](#) [MP2013GQ-33-Z](#) [L9708](#) [L970813TR](#) [030014BB](#) [059985X](#)
[NCP121AMX173TCG](#) [NCP4687DH15T1G](#) [701326R](#) [702087BB](#) [755078E](#) [TCR2EN28,LF\(S](#) [LM1117DT-1.8/NO](#) [LT1086CM#TRPBF](#)
[AZ1085S2-1.5TRE1](#) [MAX15101EWL+T](#) [NCV8170AXV250T2G](#) [TCR3DF27,LM\(CT](#) [TCR3DF19,LM\(CT](#) [TCR3DF125,LM\(CT](#)
[TCR2EN18,LF\(S](#) [MAX15103EWL+T](#) [TS2937CZ-5.0 C0](#) [MAX8878EUK30-T](#) [MAX663CPA](#) [NCV4269CPD50R2G](#) [NCV8716MT30TBG](#)
[AZ1117IH-1.2TRG1](#) [MP2013GQ-P](#) [AP2112R5A-3.3TRG1](#) [AP7315-25W5-7](#) [MAX15102EWL+T](#)