

POWER MANAGEMENT

Features

- Input Voltage as low as 1.4V
- 75mV dropout @ 0.5A
- Adjustable output from 0.5V
- Over current and over temperature protection
- Enable pin
- 10µA quiescent current in shutdown
- Full industrial temperature range
- Fully WEEE and Halogen free. RoHS compliant

Applications

- Telecom/Networking cards
- Motherboards/Peripheral cards
- Industrial applications
- Wireless infrastructure
- Set top boxes
- Medical equipment
- Notebook computers
- Battery powered systems

Description

The SC4213H is a high performance positive voltage regulator designed for use in applications requiring very low input voltage and very low dropout voltage at up to 0.5 amperes. It operates with a V_{in} as low as 1.4V. The SC4213H features ultra low dropout, ideal for applications where V_{out} is very close to V_{in} . Additionally, the SC4213H has an enable pin to further reduce power dissipation while shutdown. The SC4213H provides excellent regulation over variations in line, load and temperature.

The SC4213H is available in an SOIC-8 package. The output voltage can be set via an external divider as shown in the typical application circuit.

Typical Application Circuit

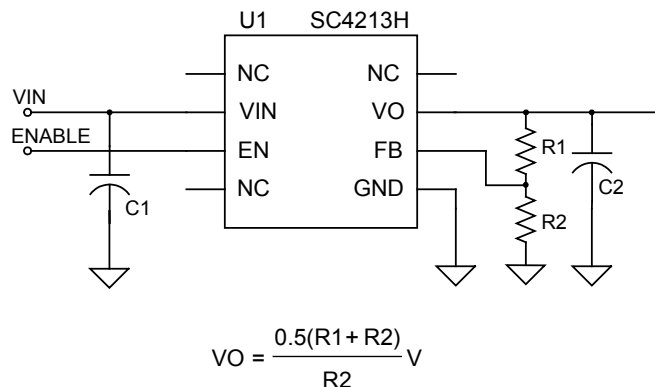

Pin Configuration

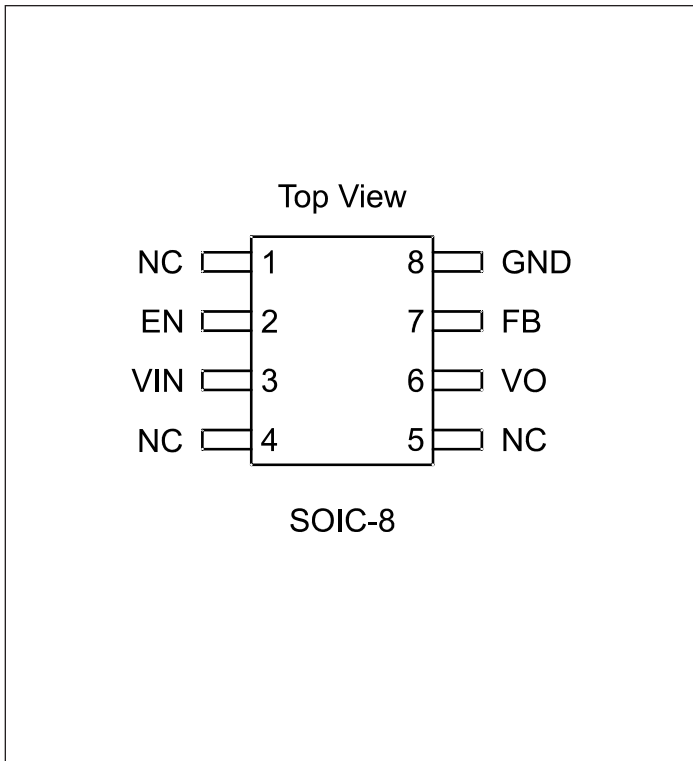

Ordering Information

Device	Package
SC4213HSTRT ⁽¹⁾⁽²⁾	SOIC-8
SC4213HEVB	Evaluation Board

Notes:

- (1) Available in tape and reel only. A reel contains 2,500 devices.
- (2) Available in lead-free packaging only. WEEE compliant and Halogen free. This component and all homogenous sub-components are RoHS compliant.

Marking Information

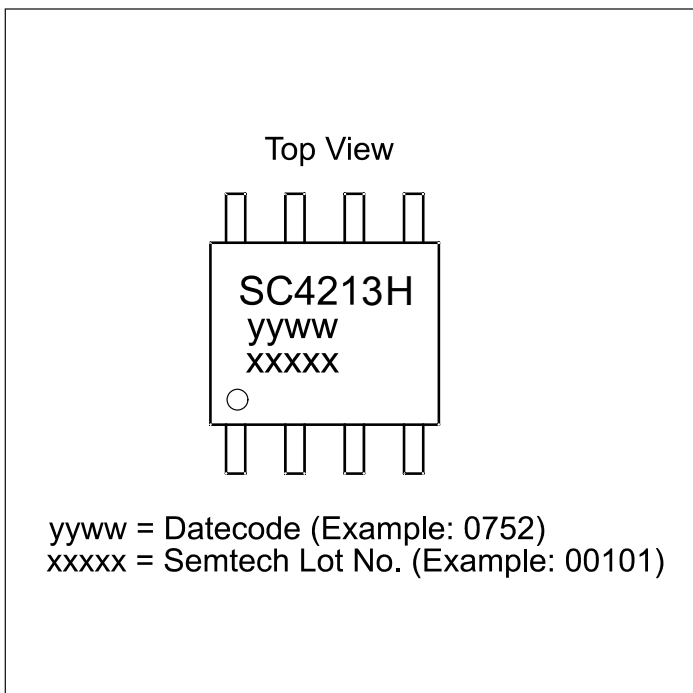

Absolute Maximum Ratings

VIN, EN, VO, FB to GND (V)	-0.3 to +7.0
Power Dissipation.....	Internally Limited
ESD Protection Level ⁽¹⁾ (kV)	4

Recommended Operating Conditions

VIN (V)	$1.4 \leq V_{IN} \leq 6.0$
Ambient Temperature Range (°C).....	$-40 \leq T_A \leq +105$
Junction Temperature Range (°C).....	$-40 \leq T_J \leq +125$
Maximum Output Current (A)	1

Thermal Information

Thermal Resistance, Junction to Ambient ⁽²⁾ (°C/W).....	105
Thermal Resistance, Junction to Case ⁽²⁾ (°C/W)	47
Maximum Junction Temperature (°C).....	+150
Storage Temperature Range (°C)	-65 to +150
Peak IR Reflow Temperature (10s to 30s) (°C)	+260

Exceeding the above specifications may result in permanent damage to the device or device malfunction. Operation outside of the parameters specified in the Electrical Characteristics section is not recommended.

NOTES:

- (1) Tested according to JEDEC standard JESD22-A114-B.
- (2) Calculated from package in still air, mounted to 3" x 4.5", 4 layer FR4 PCB with thermal vias under the exposed pad per JESD51 standards.

Electrical Characteristics

Unless specified: $V_{EN} = V_{IN}$, $V_{FB} = V_O$, $V_{IN} = 1.40V$ to $6.0V$, $I_O = 10\mu A$ to $0.5A$, $T_A = 25^\circ C$. Values in bold apply over the full operating temperature range.

Parameter	Symbol	Conditions	Min	Typ	Max	Units
VIN						
Quiescent Current	I_Q	$V_{IN} = 3.3V, I_O = 0A$			3	mA
		$V_{IN} = 6.0V, V_{EN} = 0V$		10	50	μA
VO						
Output Voltage ⁽¹⁾ (Fixed Voltage, $V_{FB} = V_O$)	V_O	$V_{IN} = V_O + 0.5V, I_O = 10mA$	-2%	V_O	+2%	V
		$V_{IN} = 1.8V, I_O = 0.5A, 0^\circ C \leq T_J = T_A \leq 85^\circ C$				
		$1.40V \leq V_{IN} \leq 6.0V, I_O = 10mA$	-3%		+3%	
Line Regulation ⁽¹⁾	$REG_{(LINE)}$	$I_O = 10mA$		0.2	0.4	%/V
Load Regulation ⁽¹⁾	$REG_{(LOAD)}$	$I_O = 10mA$ to $0.5A$		0.5	1.5	%
Minimum Load Current ⁽³⁾	I_O				10	μA
Current Limit	I_{CL}		1.5			A

Electrical Characteristics (continued)

Parameter	Symbol	Conditions	Min	Typ	Max	Units	
Dropout Voltage ⁽¹⁾⁽²⁾	V_{Dropout}	$I_{\text{O}}=0.5\text{A}$	$1.4\text{V} \leq V_{\text{IN}} < 1.6\text{V}$		75	150	mV
			$1.6\text{V} \leq V_{\text{IN}} \leq 6.0\text{V}$			125	
Feedback							
Reference Voltage ⁽¹⁾	V_{REF}	$V_{\text{IN}} = 3.3\text{V}, V_{\text{FB}} = V_{\text{OUT}}, I_{\text{O}} = 10\text{mA}$	0.495	0.5	0.505	V	
			0.490		0.510		
Feedback Pin Current	I_{ADJ}	$V_{\text{FB}} = V_{\text{REF}}$		80	200	nA	
EN							
Enable Pin Current	I_{EN}	$V_{\text{EN}} = 0\text{V}, V_{\text{IN}} = 3.3\text{V}$		1.5	5	μA	
Enable Pin Threshold	V_{IH}	$V_{\text{IN}} = 3.3\text{V}$	1.6			V	
	V_{IL}				0.4		
Over Temperature Protection							
High Trip Level	T_{HI}			160		$^{\circ}\text{C}$	
Hysteresis	T_{HYST}			10		$^{\circ}\text{C}$	

Notes:

(1) Low duty cycle pulse testing with Kelvin connections required.

(2) $V_{\text{DO}} = V_{\text{IN}} - V_{\text{O}}$ when V_{O} decreases by 1.5% of its nominal output voltage with $V_{\text{IN}} = V_{\text{O}} + 0.8\text{V}$.

(3) Required to maintain regulation. Voltage set resistors R1 and R2 are usually utilized to meet this requirement.

Stability Curve, Cout=10uF

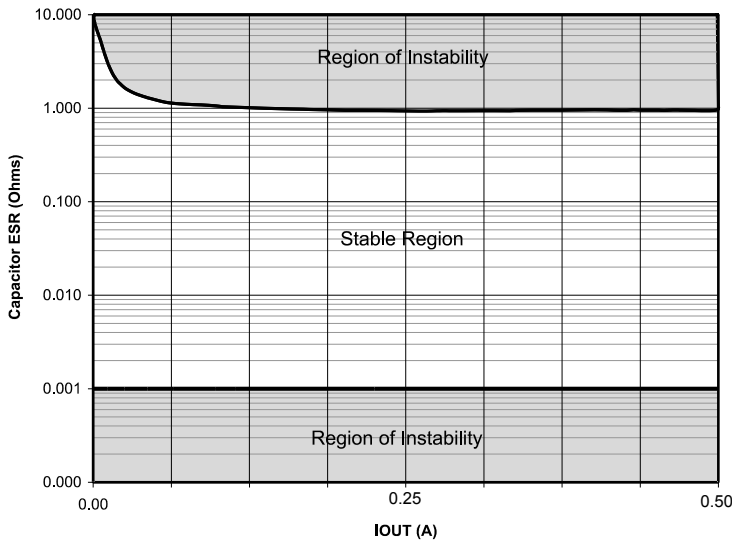

Stability Curve, Cout=100uF

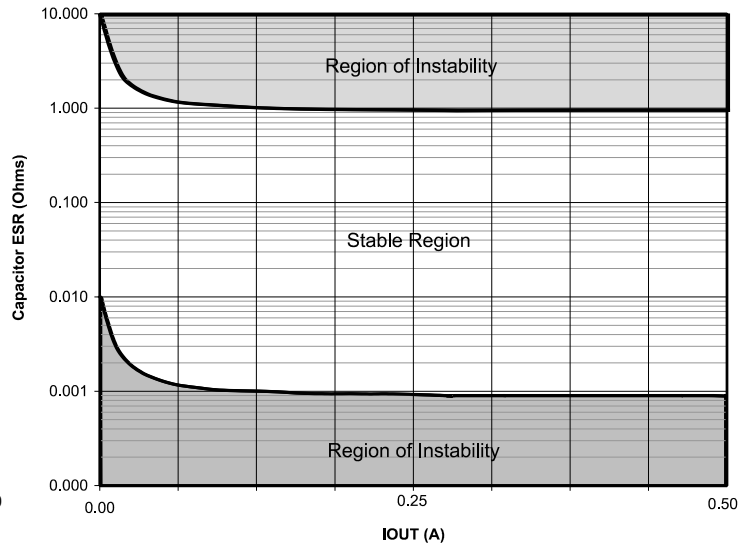

Typical PSSR Vin=5.0V; Vo=3.3V

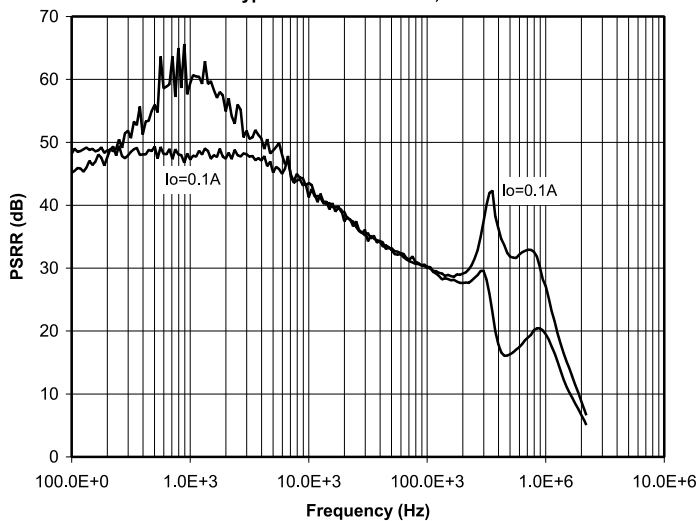

SC4213H Typical Dropout Voltage at Vout = 1.4V

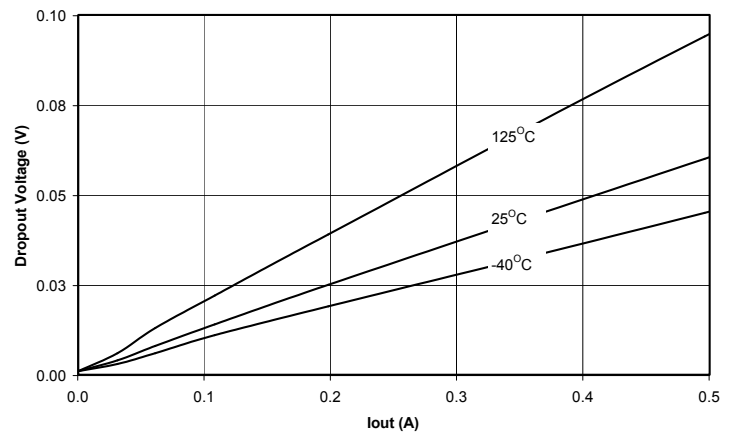

SC4213H Typical Dropout Voltage at Vout = 1.6V

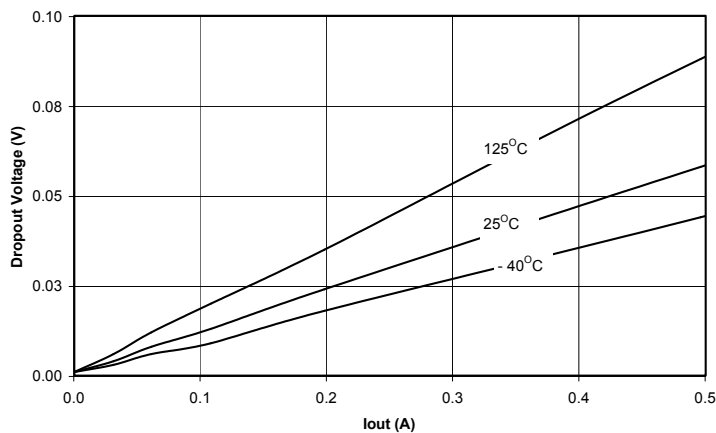

SC4213H Typical Dropout Voltage at Vout = 3.3V

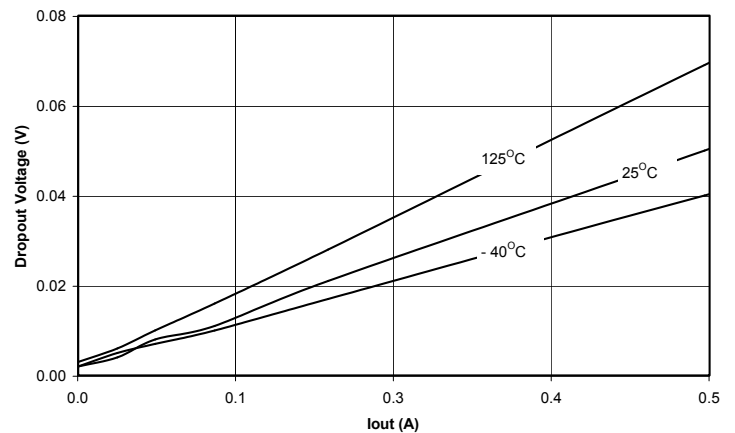

Pin Descriptions

Pin #	Pin Name	Pin Function
2	EN	Enable Input. Pulling this pin below 0.4V turns the regulator off, reducing the quiescent current to a fraction of its operating value. The device will be enabled if this pin is left open. Connect to VIN if not being used.
3	VIN	Input voltage. For regulation at full load, the input to this pin must be between (VO+ 0.5V) and 6.0V. Minimum VIN = 1.4V. A large bulk capacitance should be placed close to this pin to ensure that the input supply does not sag below 1.4V. Also a minimum of 4.7µF ceramic capacitor should be placed directly at this pin.
6	VO	The pin is the power output of the device. A minimum of 10µF capacitor should be placed directly at this pin.
7	FB	Tied to external feedback resistors to program the output voltage. The output voltage will be determined by the resistor ratio (See Application Circuits on page 1)
8	GND	Reference ground. The GND pin and the exposed die pad must be connected together at the IC pin.
1, 4, 5	NC	No Connection.
	THERMAL PAD	Pad for heatsinking purposes. Connect to ground plane using multiple vias.

Block Diagram

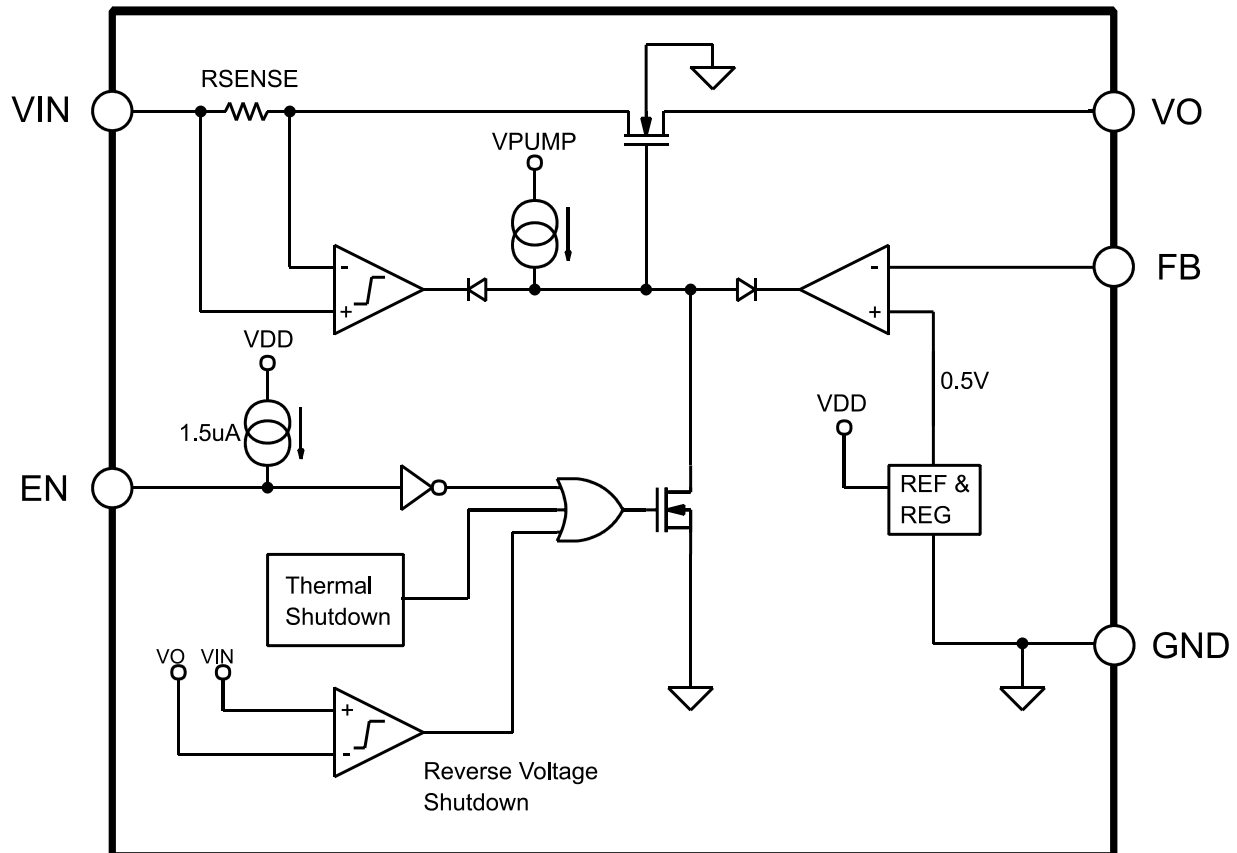

Applications Information (continued)

Introduction

The SC4213H is intended for applications where high current capability and very low dropout voltage are required. It provides a very simple, low cost solution that uses very little PCB real estate. Additional features include an enable pin to allow for a very low power consumption standby mode, and a fully adjustable output.

Component Selection

Input capacitor: A large bulk capacitance $\geq 4.7\mu\text{F}$ (output load) should be closely placed to the input supply pin of the SC4213H to ensure that V_{IN} does not sag below 1.4V. Also a minimum of $4.7\mu\text{F}$ ceramic capacitor is recommended to be placed directly next to the V_{IN} pin. This allows for the device being some distance from any bulk capacitance on the rail. Additionally, input droop due to load transients is reduced, improving load transient response. Additional capacitance may be added if required by the application.

Output capacitor: A minimum bulk capacitance of $4.7\mu\text{F}$, along with a $0.1\mu\text{F}$ ceramic decoupling capacitor is recommended. Increasing the bulk capacitance will improve the overall transient response. The use of multiple lower value ceramic capacitors in parallel to achieve the desired bulk capacitance will not cause stability issues. Although designed for use with ceramic output capacitors, the SC4213H is extremely tolerant of output capacitor ESR values and thus will also work comfortably with tantalum output capacitors.

Noise immunity: In very electrically noisy environments, it is recommended that $0.1\mu\text{F}$ ceramic capacitors be placed from V_{IN} to GND and V_{O} to GND as close to the device pins as possible.

External voltage selection resistors: The use of 1% resistors, and designing for a current flow $\geq 10\mu\text{A}$ is recommended to ensure a well regulated output (thus R_2

$\leq 50\text{k}\Omega$). A suitable value for R_2 can be chosen in the range of $1\text{k}\Omega$ to $50\text{k}\Omega$. R_1 can then be calculated from:

$$R_1 = R_2 \cdot \frac{(V_{\text{O}} - V_{\text{REF}})}{V_{\text{REF}}}$$

Enable: Pulling this pin below 0.4V turns the regulator off, reducing the quiescent current to a fraction of its operating value. A pull up resistor up to $400\text{k}\Omega$ should be connected from this pin to the V_{IN} pin in applications where supply voltages of $V_{\text{IN}} < 1.9\text{V}$ are required. For applications with higher voltages than 1.9V, the EN pin can be left open or connected to V_{IN} .

Thermal Considerations

The power dissipation in the SC4213H is given by:

$$P_{\text{D}} \approx I_{\text{O}} \cdot (V_{\text{IN}} - V_{\text{O}})$$

The allowable power dissipation will be dependant on the thermal impedance achieved in the application. The derating curve below is valid for the thermal impedance specified in the Thermal Information section on page 3.

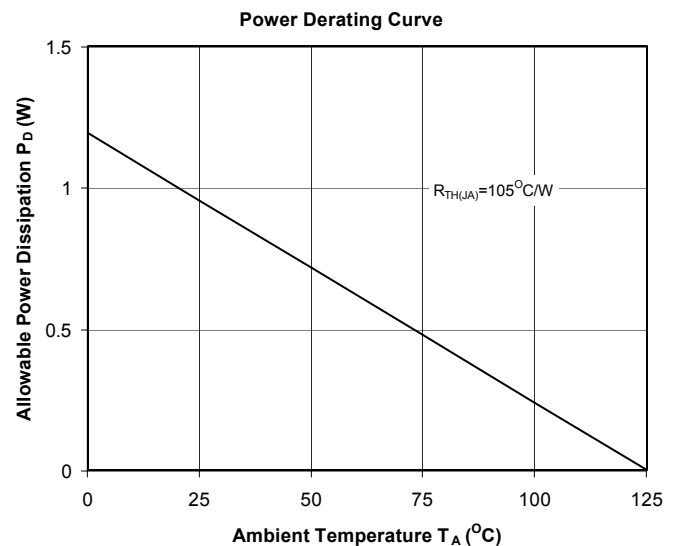

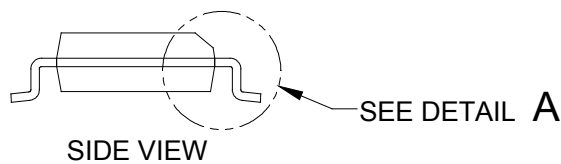
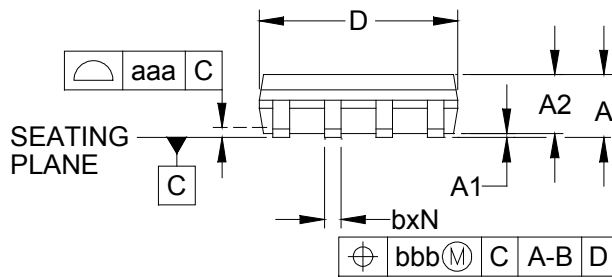
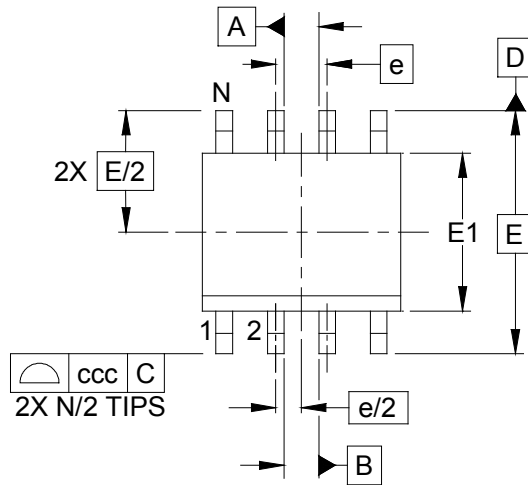
Outline Drawing — SOIC-8

DIM	INCHES			MILLIMETERS		
	MIN	NOM	MAX	MIN	NOM	MAX
A	.053	-	.069	1.35	-	1.75
A1	.004	-	.010	0.10	-	0.25
A2	.049	-	.065	1.25	-	1.65
b	.012	-	.020	0.31	-	0.51
c	.007	-	.010	0.17	-	0.25
D	.189	.193	.197	4.80	4.90	5.00
E1	.150	.154	.157	3.80	3.90	4.00
E	.236 BSC			6.00 BSC		
e	.050 BSC			1.27 BSC		
h	.010	-	.020	0.25	-	0.50
L	.016	.028	.041	0.40	0.72	1.04
L1	(.041)			(1.04)		
N	8			8		
$\theta 1$	0°	-	8°	0°	-	8°
aaa	.004			0.10		
bbb	.010			0.25		
ccc	.008			0.20		

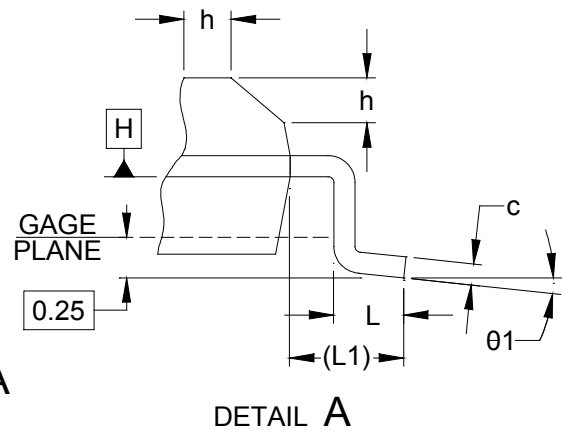
NOTES:

1. CONTROLLING DIMENSIONS ARE IN MILLIMETERS (ANGLES IN DEGREES).
2. DATUMS **-A-** AND **-B-** TO BE DETERMINED AT DATUM PLANE **-H-**
3. DIMENSIONS "E1" AND "D" DO NOT INCLUDE MOLD FLASH, PROTRUSIONS OR GATE BURRS.
4. REFERENCE JEDEC STD MS-012, VARIATION AA.

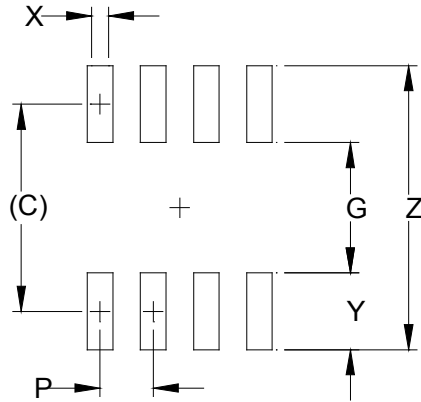
Land Pattern — SOIC-8

DIMENSIONS		
DIM	INCHES	MILLIMETERS
C	(.205)	(5.20)
G	.118	3.00
P	.050	1.27
X	.024	0.60
Y	.087	2.20
Z	.291	7.40

NOTES:

1. THIS LAND PATTERN IS FOR REFERENCE PURPOSES ONLY. CONSULT YOUR MANUFACTURING GROUP TO ENSURE YOUR COMPANY'S MANUFACTURING GUIDELINES ARE MET.
2. REFERENCE IPC-SM-782A, RLP NO. 300A.

© Semtech 2010

All rights reserved. Reproduction in whole or in part is prohibited without the prior written consent of the copyright owner. The information presented in this document does not form part of any quotation or contract, is believed to be accurate and reliable and may be changed without notice. No liability will be accepted by the publisher for any consequence of its use. Publication thereof does not convey nor imply any license under patent or other industrial or intellectual property rights. Semtech assumes no responsibility or liability whatsoever for any failure or unexpected operation resulting from misuse, neglect improper installation, repair or improper handling or unusual physical or electrical stress including, but not limited to, exposure to parameters beyond the specified maximum ratings or operation outside the specified range.

SEMTECH PRODUCTS ARE NOT DESIGNED, INTENDED, AUTHORIZED OR WARRANTED TO BE SUITABLE FOR USE IN LIFE-SUPPORT APPLICATIONS, DEVICES OR SYSTEMS OR OTHER CRITICAL APPLICATIONS. INCLUSION OF SEMTECH PRODUCTS IN SUCH APPLICATIONS IS UNDERSTOOD TO BE UNDERTAKEN SOLELY AT THE CUSTOMER'S OWN RISK. Should a customer purchase or use Semtech products for any such unauthorized application, the customer shall indemnify and hold Semtech and its officers, employees, subsidiaries, affiliates, and distributors harmless against all claims, costs damages and attorney fees which could arise.

Contact Information

Semtech Corporation
Power Mangement Products Division
200 Flynn Road, Camarillo, CA 93012
Phone: (805) 498-2111 Fax: (805) 498-3804

www.semtech.com

X-ON Electronics

Largest Supplier of Electrical and Electronic Components

Click to view similar products for [LDO Voltage Regulators](#) category:

Click to view products by [Semtech](#) manufacturer:

Other Similar products are found below :

[M38D29FFHP#U1](#) [702103A](#) [717726C](#) [742457H](#) [MP20051DN-LF-Z](#) [R5F111PGGFB#30](#) [AP7363-SP-13](#) [NCP103AMX285TCG](#)
[NCV8664CST33T3G](#) [NCV8752AMX28TCG](#) [L9454](#) [AP7362-HA-7](#) [LX13043CLD](#) [TCR3DF185,LM\(CT](#) [TCR3DF24,LM\(CT](#)
[TCR3DF285,LM\(CT](#) [TCR3DF31,LM\(CT](#) [TCR3DF45,LM\(CT](#) [TLF4949EJ](#) [L9708](#) [L970813TR](#) [030014BB](#) [059985X](#) [NCP121AMX173TCG](#)
[NCP4687DH15T1G](#) [NCV8703MX30TCG](#) [701326R](#) [702087BB](#) [755078E](#) [TCR2EN28,LF\(S](#) [LM1117DT-1.8/NO](#) [LT1086CM#TRPBF](#)
[AZ1085S2-1.5TRE1](#) [MAX15101EWL+T](#) [NCV8170AXV250T2G](#) [SCD337BTG](#) [TCR3DF27,LM\(CT](#) [TCR3DF19,LM\(CT](#)
[TCR3DF125,LM\(CT](#) [TCR2EN18,LF\(S](#) [MAX15103EWL+T](#) [TS2937CZ-5.0 C0](#) [MAX8878EUK30-T](#) [MAX663CPA](#) [NCV4269CPD50R2G](#)
[NCV8716MT30TBG](#) [AZ1117IH-1.2TRG1](#) [MP2013GQ-P](#) [AP2112R5A-3.3TRG1](#) [AP7315-25W5-7](#)